

C. E. BEAN.

Improvement in Knitting-Machines.

No. 130,558

Patented Aug. 20, 1872.

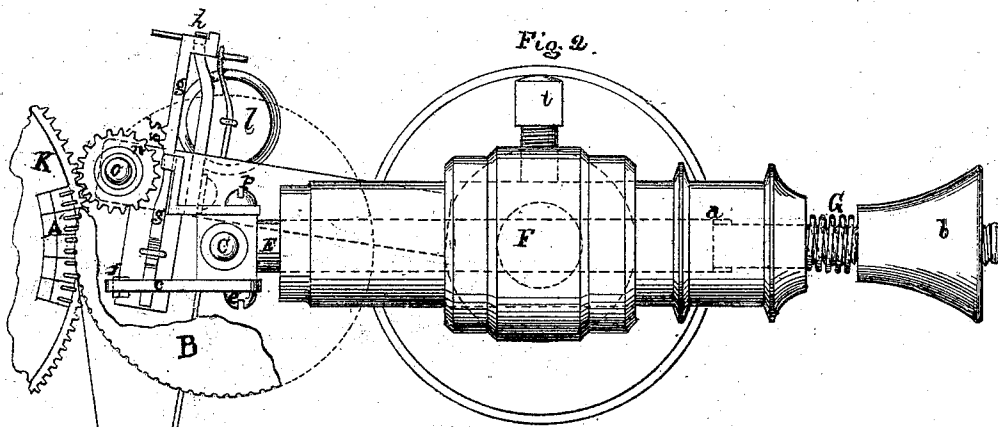
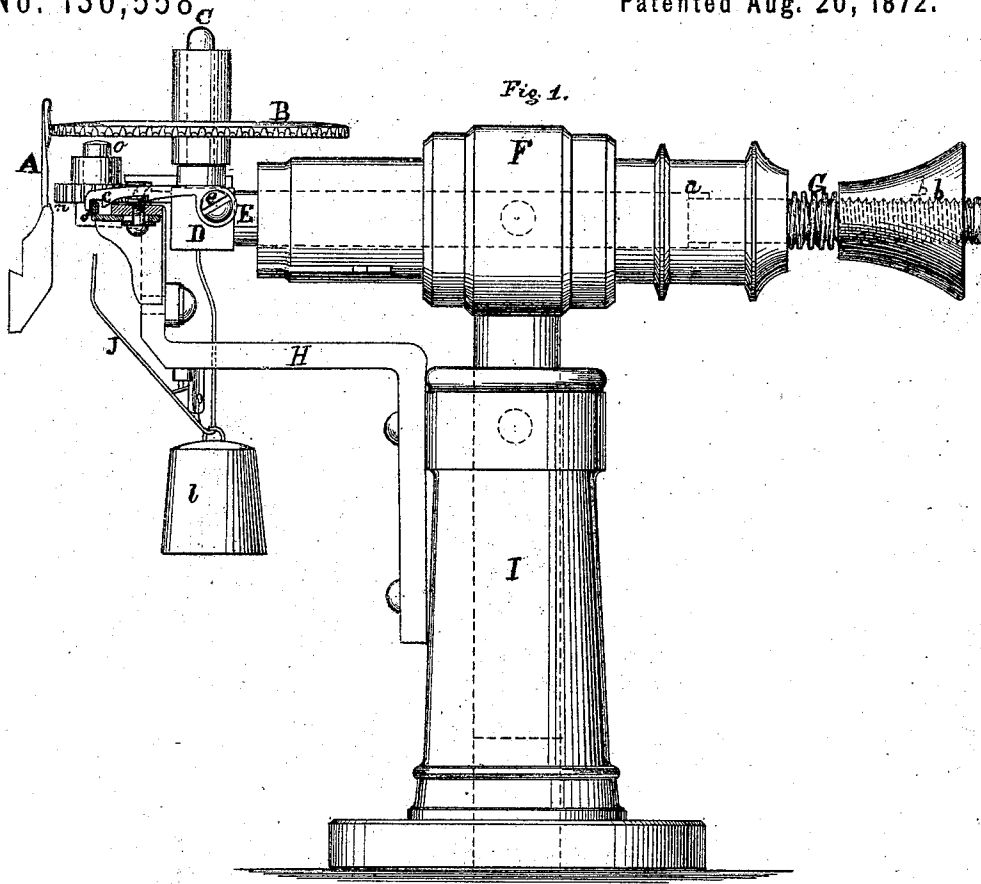

Witnesses:
Asa W. Eaton
Wm. M. Robbins

Inventor:
Charles E. Bean
 By *S. P. Smith* his atty.

C. E. BEAN.
Improvement in Knitting-Machines.

No. 130,558.

Patented Aug. 20, 1872.

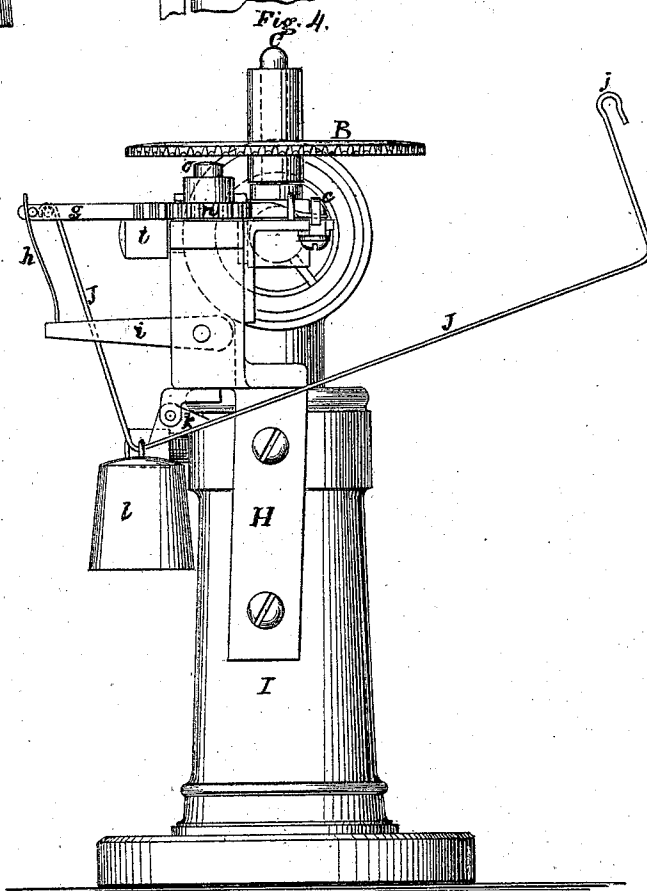
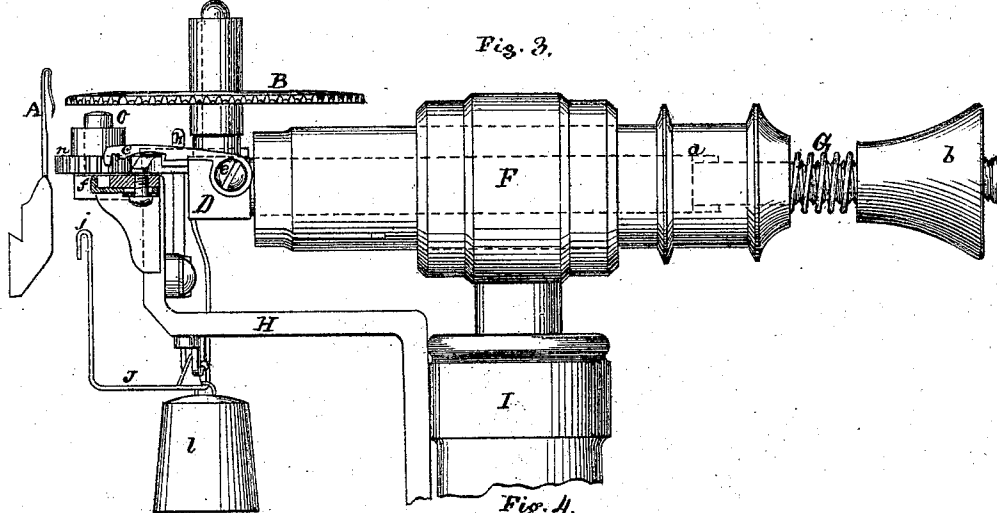

Witnesses:
 Admington Mills
 Wm. W. Robbins

Inventor:
 Charles E. Bean
 By S. P. Fitch, atty.

UNITED STATES PATENT OFFICE.

CHARLES E. BEAN, OF OSWEGO, NEW YORK, ASSIGNOR TO JEROME L. MUDGE, OF SAME PLACE.

IMPROVEMENT IN KNITTING-MACHINES.

Specification forming part of Letters Patent No. 130,558, dated August 20, 1872.

To all whom it may concern:

Be it known that I, CHARLES E. BEAN, of Oswego, Oswego county, State of New York, have invented a new and useful Knitting-Machine Attachment, of which the following is a specification, having reference to the accompanying drawing forming part thereof.

The same letters refer to like parts.

Figure 1, Plate 1, is a side elevation of a portion of a knitting-machine with which is connected my attachment. Fig. 2, Plate 1, is a top view of the same. Fig. 3, Plate 2, is a side elevation of the same, showing the mechanism of the attachment in a different position from that in Fig. 1, Plate 1. Fig. 4, Plate 2, is an end elevation of the same.

The nature of my invention consists in making the device called a presser (which is employed in that description of knitting-machines to which this attachment is applied, the office of which is to close the hook at the upper end of the needles to allow the loop forming the stitch to pass off from the needles at the proper time,) movable, and caused to recede from the needles by the mechanism hereinafter described that is set in motion by the breaking of the yarn or thread that is being knit. The mechanism of that description of knitting-machines, a portion of which is represented in the drawing, is well known to those skilled in the art, the knitting being accomplished by a series of hooked needles arranged in the perimeter of a revolving horizontal cylinder, each needle, in turn, as it passes a given point, taking up the thread to form a stitch, the loop of the last preceding stitch being thrown off from the needle, the presser closing the hooked end down upon the shaft of the needle to allow the loop to pass over it. In knitting with these machines, whenever the thread breaks, (the forming of loops upon the needles being thereby suspended,) as the needles successively come in contact with the presser, and the hooked end is thereby closed down upon the shaft of the needle, the last loop formed on the needle is necessarily thrown off, and the knit web is thereby detached from as many needles as are brought in contact with the presser before the movement of the machine is arrested. This action of the machine occasions serious inconvenience and loss. The ob-

ject of my attachment is to obviate this difficulty, and prevent the loops being thrown off from the needle whenever there is a breaking of the thread or yarn until the machine can be stopped and the thread reunited.

A, Fig. 1, is a single one of the series of knitting-needles, a number of which is shown in position in a segment of the cylinder K at A, Fig. 2. B is the presser, consisting of a horizontal disk-wheel, having a series of notches in its periphery designed to engage with the hooked end of the needle, and press it down against its shaft, thereby closing the loop formed by the hooked end. This disk B revolves loosely upon the shaft C that is fixed upon the upper side of the head D of the spindle E. The spindle E passes through the cross-head F, and upon the opposite end is placed a spiral spring, G, one end of which rests against the face of the cross-head and the other against a nut, *b*, upon the end of the spindle, by its recoil tending to throw the spindle away from the needle and of course carry with it the presser B. *c* is a latch pivoted at *e* in the head D of the spindle E. A notch in the end of this latch engages with a stop or catch, *f*, secured upon the bracket H that is attached to the standard I, and upon which the mechanism of my attachment is mounted. When this latch is in the position seen in Fig. 1 it is evident that it will hold the presser at a fixed point in contact with the needles against the pressure of the spring G; and in this position it is designed that the machine shall be run, and which is the usual position of the presser, as such machines are constructed, without my attachment. Now, to cause the presser to recede from the needles by the breaking of the thread, I provide a sliding shaft, *g*, one end of which being formed wedge-like or with an inclined plane lies under the latch *c*, and which, by being pushed forward under the latch, will throw the latch up and disengage it from the stop *f*. *h* is a leaf-spring fixed in the arm *i* which acts against a pin in the end of the sliding shaft *g* to throw the said shaft forward under the latch *c*. Against the action of this spring *h* the shaft *g* is held back from sliding under the latch by the long lever J, which is pivoted at *k* upon the bracket H and acts against a pin near the end of the

shaft *g*. Upon the opposite end of this lever is a hook or eye, *j*, through which the yarn or thread is passed on its way to the needles. On the opposite side of the pivot *k* a small weight, *l*, is suspended upon the lever *J*, and the combined action of this weight and the tension of the thread or yarn are sufficient to elevate the hooked end of the lever sufficiently to hold the shaft *g* back against the pressure of the spring *h*. *n* is a small spur-gear wheel pivoted upon the shaft *o* fixed in the arm *p*, with which a corresponding gear on the periphery of the needle-cylinder *K* engages, and to which a constant rotary motion is imparted when the cylinder *K* is in motion. Upon the side of the shaft *g* toward the gear *n* are two cogs, *s s*, which, whenever the shaft *g* is thrown forward by the action of the spring *h*, engage with the gear-wheel *n*, and, that being in motion, the shaft *g* is thereby driven under the latch *c*, throwing it off from the stop *f*, when the pressure of the spring *G* will force the spindle *E*, and with it the presser *B*, away from contact with the needles *A* and into the position seen in Fig. 3 of the drawing.

In this mechanism it is necessary that the spring *h* should exert no more force than may be overcome by the tension of the thread passing through the eye of the lever *J* and the weight *l*, and that force would not be sufficient to drive forward the shaft *g* underneath the latch *c* far enough to disengage the latch from the stop *f*; but it is sufficient to throw the cogs *s s* into engagement with the gear *n*, when the latter completes the movement of the shaft whereby the latch is thrown up.

The operation of this attachment is as follows: The mechanism being in position as shown in Fig. 1, the knitting is carried on by the movement of the knitting-machine so long as the thread or yarn remains unbroken, precisely as it is in the same machine without my attachment, the yarn or thread being passed through the eye *j* of the lever *J* and its tension, together with the weight *l*, preventing the mechanism of my attachment from coming into action. The parts being in the position as

seen in Figs. 1 and 2 of the drawing, the moment the thread is broken the recoil of the spring *h* throws forward the shaft *g*, the cogs *s s* engage with the gear *n*, whereby the said shaft is forced underneath the latch *c*, which, being thereby disengaged from the stop *f*, permits the spindle *E* and with it the presser *B* to be thrown by the recoil of the spring *G* away from the needles *A* and into the position seen in Fig. 3 of the drawing. The hooks at the upper end of the needles being now relieved from the action of the presser, remain open, and the loops that have already been formed on the needles, instead of passing over the ends of the hooks, and off from the needles, pass up into the loops of the hooks, and thus remain on the needles, and thereby the web retains its connection with them. By means of the nut *b* upon the spindle *E* the pressure of the spring *G* may be adjusted as desired, and the distance to which the spindle may be allowed to recede from the needles, may be regulated by the set-screw *t*.

What I claim as my invention, and desire to secure by Letters Patent, is—

1. The combination of the needles *A* with the presser *B*, the latter being made movable and caused to recede from the needles by the special mechanism herein described, that is brought into action by the breaking of the thread or yarn employed in knitting, substantially as described.

2. The combination of the shaft *g*, the latch *c*, the gear *n*, and the spring *h*, substantially as and for the purpose specified.

3. The combination of the presser *B*, the spindle *E*, the spring *G*, the latch *c*, the stop *f*, and the shaft *g*, substantially as and for the purpose specified.

4. The combination of the lever *J*, the shaft *g*, the spring *h*, the latch *c*, and the presser *B*, substantially as and for the purpose specified.

CHAS. E. BEAN.

Witnesses:

JOSEPH OWEN,
A. E. SHEPARD.