

M. A. GROBL.
 FLUE CLEANER.
 APPLICATION FILED OCT. 20, 1915.

1,166,901.

Patented Jan. 4, 1916.

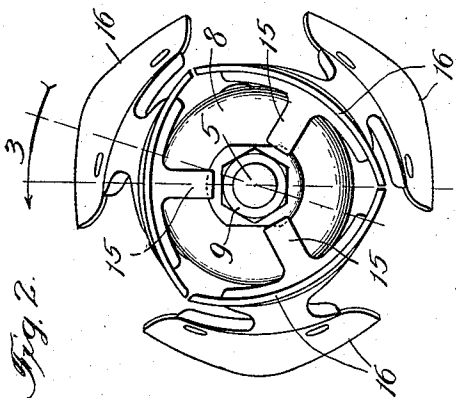

Fig. 2.

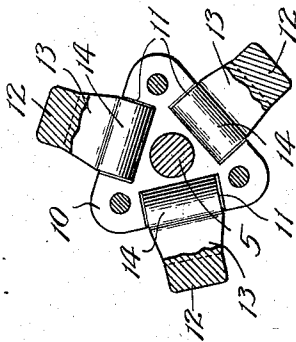

Fig. 4.

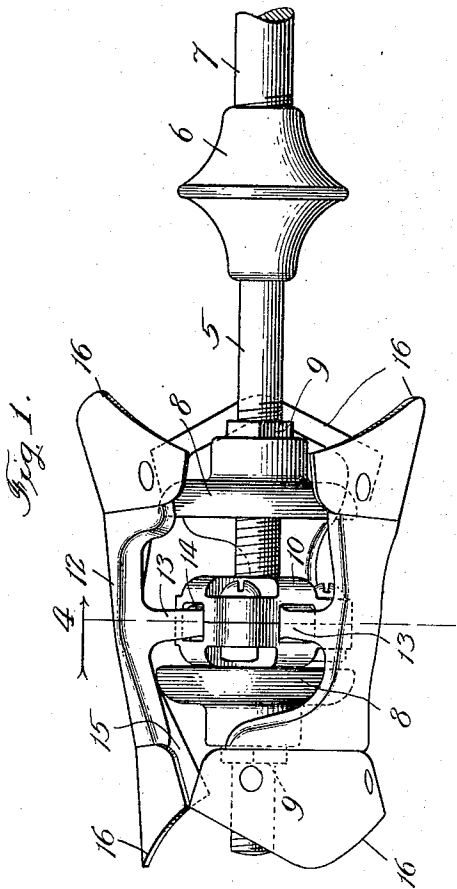

Fig. 1.

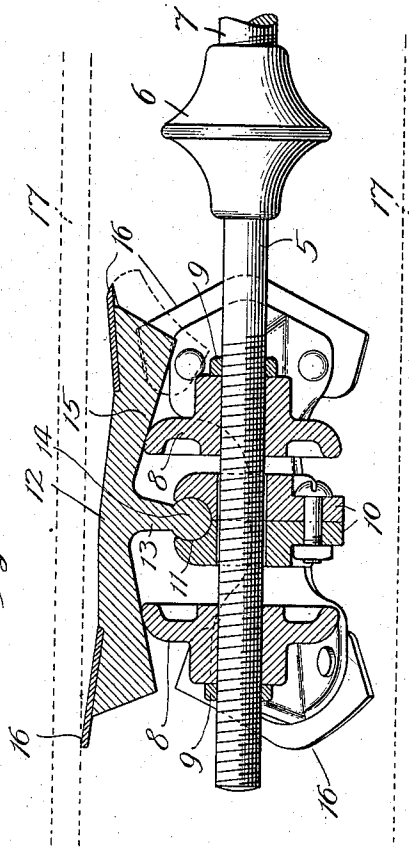

Fig. 3.

Witnesses:
E. O. Taylor
Chas. H. Buell

Inventor:
 Mathias A. Grobl,
 By *Dyersforth, Lee, Britton and Wiley*
 Attys.

UNITED STATES PATENT OFFICE.

MATHIAS A. GROBL, OF BROOKFIELD, ILLINOIS, ASSIGNOR OF ONE-HALF TO GEORGE SCHLITT, OF CHICAGO, ILLINOIS.

FLUE-CLEANER.

1,166,901.

Specification of Letters Patent.

Patented Jan. 4, 1916.

Application filed October 20, 1915. Serial No. 56,917.

To all whom it may concern:

Be it known that I, MATHIAS A. GROBL, a citizen of the United States, residing at Brookfield, in the county of Cook and State of Illinois, have invented a new and useful Improvement in Flue-Cleaners, of which the following is a specification.

The object of my invention is to provide an improved construction of cleaner for scraping the incrustations or soot off the interior surfaces of flues upon which they accumulate, as in the case of boiler-flues.

My invention relates to the class of such cleaners involving, as salient features of the device, a stem carrying arms provided with scrapers arranged about the stem and adapted to be contracted for introduction into a flue at its end and to be expanded in the flue to engage the matter to be removed.

In the accompanying drawing, Figure 1 shows my improved flue-cleaner by a view in side elevation; Fig. 2 is an end view of the same; Fig. 3 is a section on line 3, Fig. 2, showing the cleaner inside a flue indicated by dotted representation, and Fig. 4 is a section on line 4, Fig. 1.

A screw-threaded stem 5, provided on one end with a socket 6, into which to screw an operating rod or handle 7 of desired length, carries adjustably and in spaced relation on the screw-thread, similar disk-like cams 8, shown to be provided with convex circumferential edges and central hubs, at which they screw on the stem, and to be fastened in adjusted position on the latter by nuts 9. Between the cams is loosely mounted on the stem, to adapt it to slip back and forth thereon, a head 10 preferably made, as shown, in two similar halves, which are bolted together and form at intervals on their peripheries joint-sockets 11 (Fig. 3), of which three are preferably provided for the purpose hereinafter explained. Arms 12 have necks 13 intermediate their ends terminating in rounded heads 14, which fit in the sockets 11 and form flexible joints permitting the arms to rock on the head. Each arm is expanded toward its ends, the expanded sections containing offsets in their outer faces; and fingers 15, which extend along the inner faces of the arms at opposite sides of their necks, are tapered on their inner edges from their outer ends. These fingers, which preferably form integral parts of the arms, cross the respective cams 8.

Blades 16, of the preferred shape illustrated to form tapering cutting edges, are riveted to the arms at their aforesaid offset sections, whereby their outer surfaces are flush, or substantially so, with those of the parts of the arms between the offsets. The blades, which are of transversely curved shape and conform to the shape of the offset end-sections of the arms to which they are fastened, are so set that those on corresponding ends of the rocking arms are staggered with relation to those on the opposite ends thereof.

In applying the cleaner to its purpose, preparatory to inserting it into the near end of a flue 17 (Fig. 3), the operator permits or causes the head 10 to slip forwardly on the stem 5 until it abuts against the advance cam 8, which should be so set as to then be at the inner ends of the tapered fingers, whereby the tapered fingers on the opposite ends of the arms are brought into contact at their wider portions with the rearmost cam 8, there to spread them apart. The effect of this spreading is to converge the circumferential series of the advance arm-ends and cutters thereon to a diameter that will facilitate inserting the cleaner into the flue-end, more or less reduced in diameter by the matter therein to be removed. When once thus inserted, the rod 7 is advanced to drive the cleaner through the flue, in which movement the obstruction to the advance cutters by the accumulated matter on the inner flue-surface slips the head 10 backwardly until arrested by abutting against the face of the rear cam, thus affording a stop whereby the narrower ends of the adjacent fingers are brought contiguous to that cam, which is properly set for the purpose, and the wider ends of the advance fingers are brought into contact with the other cam to expand the adjacent arm-ends and cause the cutters thereon to expand to the internal diameter of the flue and insure thorough removal of the matter which they encounter upon it. In reversing the action of the cleaner, the head slips against the face of the forward cam 8 to expand the rear arm-ends and cutters thereon for the purpose already described; and by reason of the staggered relation between the advance and rear cutters, the latter attack and remove the matter on the inner flue-surface which was missed by the former in their advance-movement. As will be understood, though, while it is obviously

preferable to provide both sets of cutters, my invention contemplates the provision of only one set thereof.

5 With new or fresh cutters in my cleaner, the spacing apart of the cams may be such as to cause the cam for the cutters under
 10 action to expand them to the diameter of the flue being cleaned; and thus the range of expansibility will adapt the cleaner, by
 15 setting the cams closer together or farther apart, to flues of a considerable range in diameter. Another important advantage afforded by the adjustability of the cams is to compensate for the wear on the cutting
 20 edges of the blades. Such wear reduces the diameter of the circumferential series of the blades, and to cause them to be expanded when worn to the diameter of a given flue, the cams are set, by turning them
 25 on the thread of their supporting stem, to space them as much farther apart as is necessary to cause them to be encountered by the fingers that much farther toward their wider ends.

30 I realize that considerable variation is possible in the details of construction thus specifically shown and described, and I do not intend by illustrating a single, specific embodiment of my invention to be limited thereto, my intention being in the following claims to claim protection upon all the novelty there may be in my invention as broadly as the state of the art will permit.

What I claim as new and desire to secure by Letters Patent is—

1. A flue-cleaner comprising, in combination, a threaded stem, a pair of disk-like cams relatively adjustable on the stem-thread, a head loosely supported on the stem to slip between the cams and provided with
 40 a circumferential series of sockets, arms having necks between their ends terminating in heads confined in said sockets to permit rocking movement of the arms, fingers
 45 on and extending lengthwise along the inner faces of the arms and presenting inwardly tapering edges to the outer cam-peripheries, and blades on the outer ends of the arms.

2. In a flue-cleaner, the combination of a threaded stem, a pair of cams relatively
 50 adjustable on the stem-thread, a head loosely supported on the stem to slip between the cams and provided with a circumferential series of sockets, arms having offset end-
 55 sections and necks between their ends terminating in heads confined in said sockets to permit rocking movement of the arms, tapered fingers extending lengthwise of the arms along their inner faces at both sides of said necks, and blades secured to the
 60 arms at said offset sections.

MATHIAS A. GROBL.

In presence of—

A. C. FISCHER,
 K. O'NEILL.

Copies of this patent may be obtained for five cents each, by addressing the "Commissioner of Patents, Washington, D. C."