

THOMAS G. KENNY.

Improvement in Coke-Oven.

No. 128,151.

Patented June 18, 1872.

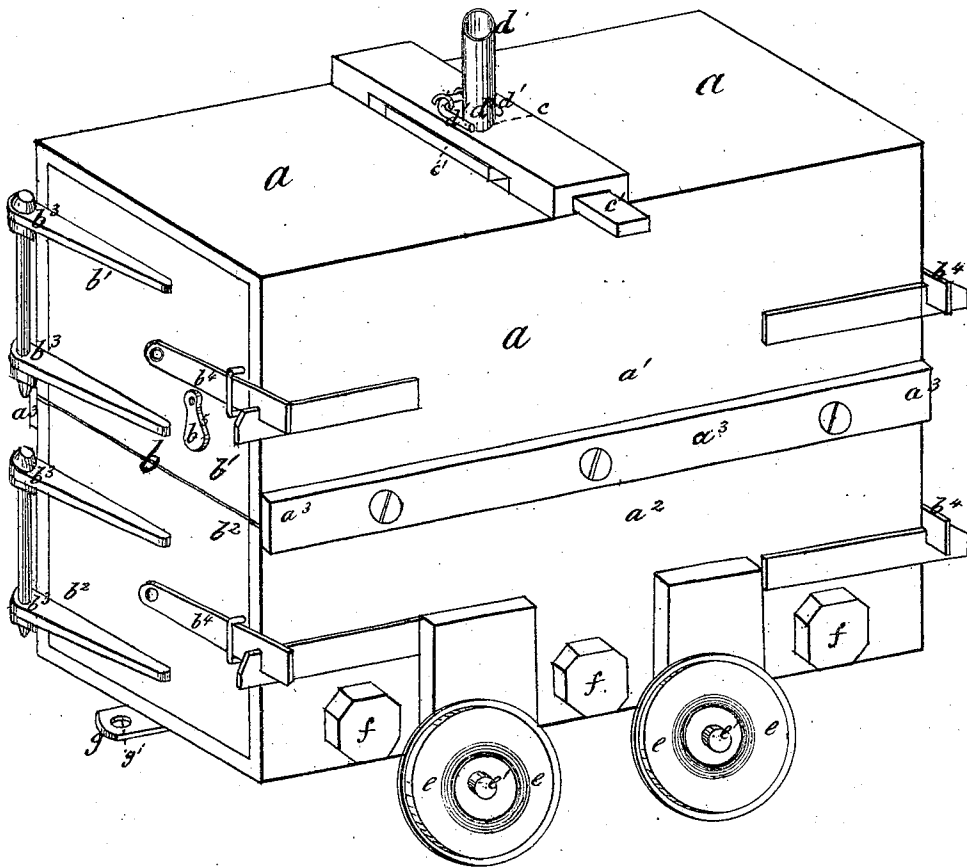

Witnesses
Bernard Keelao
Michael Kenny

Inventor:
Thomas G. Kenny

UNITED STATES PATENT OFFICE.

THOMAS G. KENNY, OF PROSPECT, PENNSYLVANIA.

IMPROVEMENT IN COKE-OVENS.

Specification forming part of Letters Patent No. 128,151, dated June 18, 1872.

To all whom it may concern:

Be it known that I, THOMAS G. KENNY, of Prospect borough, Cambria county, and State of Pennsylvania, have invented a new and useful Improvement in Oven for Burning Coke, of which the following is a specification:

This invention relates to an improved portable coke-oven, particularly applicable to use in connection with iron or other furnaces, whereby coal may be made into coke for smelting purposes at or near the blast-furnace, so that the oven may be brought to the furnace at the time required and the coke discharged directly from the oven into the furnace while in a hot state, instead of being made at a distance and transported by carts or other means to the furnace in a cold state. By this means great saving, not only in fuel consumed, but also of waste in transporting the coke from place to place, is obtained, and the coke is supplied to the furnace free from hydrogen.

In carrying out my invention I employ an oblong chamber or oven, formed of cast, boiler, or wrought iron, the parts of which are secured together by rivets, screws, or otherwise, and lined throughout with fire-brick, or fire-clay, or other suitable material capable of resisting the action of heat and protecting the metallic portion of the oven. This oven is arranged with doors at each end for the insertion and withdrawal of the fuel employed to heat the oven prior to the insertion of the coal to be coked; also for the discharge of the coke to the blast-furnace or otherwise, as required. The oven and also the doors are, by preference, formed in halves—an upper and a lower—in order that the fire-clay, or fire-brick, or other substance with which the oven is lined may be more readily repaired or replaced when required. The halves of the oven are retained in position by means of projecting rims or flanges, or by other suitable means. The doors are arranged to turn on hinges, and are retained in an open or closed position by means of the latches, or it may be bolts, or by other suitable retaining means. The coal to be coked is supplied to the oven by means of an opening or hopper formed in the upper portion of the oven, which is opened or closed at pleasure by a slide or valve. This opening also serves to regulate the draught of the oven, and it is provided with a smoke-stack or chimney, so

arranged and connected to the oven by levers that it can be moved into or out of position at pleasure, and serves, when required, to carry off the smoke, &c., from the oven. The apparatus is arranged and supported upon wheels turning on axles, connected to the lower part of the apparatus, and these wheels may be formed to run in grooves, or on rails, or otherwise, according to circumstances. Apertures are formed in the lower portion of the oven, through which bars or rods may be inserted when required to break up the coked mass in the interior. These apertures are, by preference, closed by plugs or stoppers. But that my invention may be fully understood, I will describe the same in detail by aid of the accompanying drawing.

Description of the Drawing.

The figure is a perspective view of my improved oven for burning coke.

a a is the oblong chamber or oven, the various parts of which are formed of iron securely riveted or screwed together, and lined throughout with fire-brick, or fire-clay, or other material capable of resisting the destructive action of heat and protecting the metallic portion of the oven. The oven *a* is provided with doors *b* at each end, for the insertion and withdrawal of the fuel employed to heat the oven prior to the insertion of the coal to be coked, and also for the discharge of the coke to the blast-furnace or otherwise, as required. The oven *a* is formed in two parts, *a¹ a²*, and the doors *b* at each end are also divided into halves, *b¹ b²*, in order that the fire-clay, fire-brick, or other substance with which the oven is lined may be readily repaired or replaced when required. The halves *a¹ a²* of the oven *a* are retained in position by means of the projecting rims or flanges *a³*, or by other suitable means. The doors *b* are arranged to turn on hinges *b³*, and be securely retained in an open or closed position by means of latches *b⁴*, or by other means. The coal to be coked is supplied to the oven *a* by means of an opening or hopper, *c*, formed on the upper portion *a¹* of the oven *a*, which is opened or closed at pleasure by means of a slide or valve, *c'*. This opening *c* and valve *c'* also serve to regulate the draught of the oven *a*, and it is provided with a smoke-stack or chimney, *d*, connected

to the upper half a^1 of the oven a by means of a pair of hinged levers, d' , so that it can be moved into or out of position at pleasure, according to whether the opening or hopper c is required to be used for the purpose of filling the oven with coal; or as a means of escape for the gases, &c., evolved from the coal. The apparatus is arranged and supported on wheels e turning on axles e' , connected to the lower part a^2 of the oven. The wheels e may be either formed plain or with grooves or flanges to run on rails or otherwise, according to circumstances. Apertures are formed in the lower half a^2 of the oven, through which bars or rods may be inserted when required to break up the coked mass in the interior before discharging the same from the oven. These apertures I have shown closed by means of plugs or stoppers f , but this may be varied.

When it is desired to commence the manufacture of coke in my improved oven, I first light a fire of wood or other suitable combustible material in the oven a , and heat it red hot. I then open one or both of the doors b , and thoroughly rake out all ashes, &c., from the oven a , and have it perfectly clean. I then close the doors b and insert the coal to be coked through the aperture or hopper c , the chimney or smoke-stack d having been previously moved out of the way. The chimney or smoke-stack d is then replaced over the opening or hopper c , and the coal will be coked by means of the heat contained in the oven without requiring external application of heat to the oven. The draught is regulated by the slide or valve c' . When the coal has been sufficiently coked the apparatus is moved by means of an incline or other means to the mouth of the furnace; the doors b at one end are then thrown open and secured back out of the way; the apparatus is then tilted up and the coke discharged in a heated state directly from the oven a into the blast-furnace, thereby retaining the greatest possible amount of heat in the same, and consequently economizing the consumption of coke, as well as preventing any loss by the transportation of the coke from place to place by the ordinary means. The apparatus, having been thus emptied of its contents, will retain sufficient heat to fire fresh coal, and the operation carried on as before. A series of ovens

similarly arranged may be employed in connection with one furnace. It will be seen that by this apparatus coal placed in the oven a will be converted into coke and conveyed while in its fiery red-hot state into a blast or other furnace, without necessitating the cooling of the heated mass by the application of water, as is the case with the ordinary mode of manufacture. All filling of barrows, trucks, or other carrying means is avoided. g is a bar or rod running the whole length of the under side of and secured to the lower half a^2 of the oven a , which is provided at g' with an eye or loop for the purpose of receiving a hook or other connecting means from the draft-chain of a horse or other hauling power. b^5 is a plate or cover to a small opening in the upper part b^1 of the door b , for the purpose of enabling the operator to inspect the state of the coal during the coking operation.

What I claim, and desire to secure by Letters Patent, is—

1. A portable coke-oven, made of cast or wrought iron and lined with a fire-resisting material, and mounted upon wheels, substantially as and for the purpose set forth.

2. A coke-oven mounted upon wheels, provided with a hinged chimney or smoke-stack, d , for operating substantially as and for the purpose set forth.

3. A portable coke-oven mounted on wheels, constructed and arranged to discharge its contents direct into a furnace, substantially as set forth.

4. A coke-oven formed of cast or wrought iron or other suitable material, and lined with a fire-resisting material, as described, in combination with the doors b , opening or hopper c , valve c' , hinged smoke-stack d , and openings adapted to receive the plugs b , arranged and operating substantially as described.

5. A portable coke-oven, arranged and constructed so as to enable coal placed in such oven to be converted into coke and conveyed direct while in a red-hot state into a blast or other furnace, substantially as set forth.

THOMAS G. KENNY.

Witnesses:

BERNARD KEELAN,
MICHAEL KENNY.