



- (51) International Patent Classification:
A61B 8/00 (2006.01) *A61N 7/00* (2006.01)
- (21) International Application Number:
PCT/US2019/014617
- (22) International Filing Date:
22 January 2019 (22.01.2019)
- (25) Filing Language: English
- (26) Publication Language: English
- (30) Priority Data:
62/622,394 26 January 2018 (26.01.2018) US
- (71) Applicant: **ULTHERA, INC.** [US/US]; 1840 S. Stapley Drive, Suite 200, Mesa, Arizona 85204 (US).
- (72) Inventor: **EMERY, Charles, D.**; 921 South Porter Court, Gilbert, Arizona 85296 (US).
- (74) Agent: **CHRISTENSEN, Michael, R.**; 2040 Main Street, 14th Floor, Irvine, California 92614 (US).
- (81) Designated States (unless otherwise indicated, for every kind of national protection available): AE, AG, AL, AM, AO, AT, AU, AZ, BA, BB, BG, BH, BN, BR, BW, BY, BZ, CA, CH, CL, CN, CO, CR, CU, CZ, DE, DJ, DK, DM, DO, DZ, EC, EE, EG, ES, FI, GB, GD, GE, GH, GM, GT, HN, HR, HU, ID, IL, IN, IR, IS, JO, JP, KE, KG, KH, KN, KP, KR, KW, KZ, LA, LC, LK, LR, LS, LU, LY, MA, MD, ME,

MG, MK, MN, MW, MX, MY, MZ, NA, NG, NI, NO, NZ, OM, PA, PE, PG, PH, PL, PT, QA, RO, RS, RU, RW, SA, SC, SD, SE, SG, SK, SL, SM, ST, SV, SY, TH, TJ, TM, TN, TR, TT, TZ, UA, UG, US, UZ, VC, VN, ZA, ZM, ZW.

- (84) Designated States (unless otherwise indicated, for every kind of regional protection available): ARIPO (BW, GH, GM, KE, LR, LS, MW, MZ, NA, RW, SD, SL, ST, SZ, TZ, UG, ZM, ZW), Eurasian (AM, AZ, BY, KG, KZ, RU, TJ, TM), European (AL, AT, BE, BG, CH, CY, CZ, DE, DK, EE, ES, FI, FR, GB, GR, HR, HU, IE, IS, IT, LT, LU, LV, MC, MK, MT, NL, NO, PL, PT, RO, RS, SE, SI, SK, SM, TR), OAPI (BF, BJ, CF, CG, CI, CM, GA, GN, GQ, GW, KM, ML, MR, NE, SN, TD, TG).

Declarations under Rule 4.17:

- as to applicant's entitlement to apply for and be granted a patent (Rule 4.17(ii))
- as to the applicant's entitlement to claim the priority of the earlier application (Rule 4.17(iii))

Published:

- with international search report (Art. 21(3))

(54) Title: SYSTEMS AND METHODS FOR SIMULTANEOUS MULTI-FOCUS ULTRASOUND THERAPY IN MULTIPLE DIMENSIONS

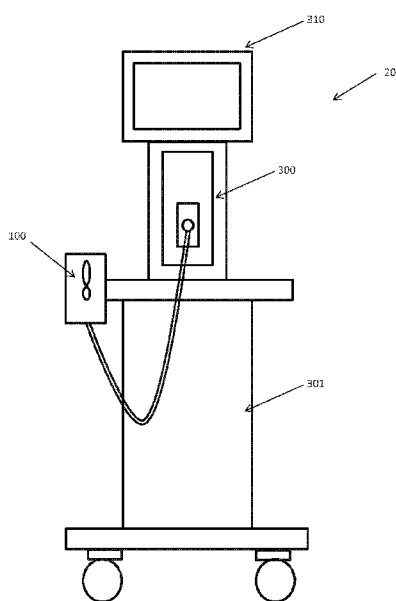

FIG. 1A

(57) Abstract: Embodiments of a dermatological cosmetic treatment and/or imaging system and method adapted to alter placement and position of multiple cosmetic treatment zones in tissue from ultrasound beams from a transducer, simultaneous multi-focus therapy at multiple depths, and/or dithering ultrasound beams from a transducer to alter placement and position of multiple cosmetic treatment zones in tissue. The system can include a hand wand, a removable transducer module, and a control module. In some embodiments, the cosmetic treatment system may be used in various cosmetic procedures.

WO 2019/147596 A1

SYSTEMS AND METHODS FOR SIMULTANEOUS MULTI-FOCUS ULTRASOUND THERAPY IN MULTIPLE DIMENSIONS

INCORPORATION BY REFERENCE

[0001] U.S. Provisional Patent Application Nos. 62/622,394 filed on January 26, 2018 is incorporated herein by reference in its entirety for all purposes.

BACKGROUND

Field

[0002] Several embodiments of the invention relate to energy-based noninvasive treatments for obtaining aesthetically and/or cosmetically enhancing effects on skin and/or tissue near the skin of a human face, head, neck, and/or body with simultaneous or near simultaneous delivery of energy to multiple dimensions (e.g., depths, heights, widths, spacings, orientations, placements) of tissue under a skin surface.

Description of the Related Art

[0003] Some cosmetic procedures involve invasive procedures that may require invasive surgery. Patients not only have to endure weeks of recovery time, but also are frequently required to undergo risky anesthetic procedures. Non-invasive energy-based therapeutic devices and methods are available, but may have various shortcomings with respect to efficiency and effectiveness.

SUMMARY

[0004] In several embodiments, provided are systems and methods that successfully achieve an aesthetic effect using targeted and precise ultrasound to cause a visible and effective cosmetic result via a thermal pathway by splitting an ultrasound therapy beam to two, three, four, or more simultaneous focal zones for performing various treatment and/or imaging procedures. In various embodiments, an ultrasound system is configured for focusing ultrasound to produce localized, mechanical motion within tissues and cells for the purpose of producing either localized heating for tissue coagulation or for mechanical cellular membrane disruption intended for non-invasive aesthetic use. In various embodiments, an ultrasound system is configured for lifting a brow (e.g., an eyebrow lift). In various embodiments, an ultrasound system is configured for lifting lift lax, loose or sagging tissue,

such as submental (beneath the chin) and neck tissue. In various embodiments, an ultrasound system is configured for improving lines and wrinkles of the décolleté. In various embodiments, an ultrasound system is configured for reducing fat. In various embodiments, an ultrasound system is configured for reducing the appearance of cellulite. In some embodiments, a system is provided for both reducing fat and subsequently treating the loose skin that results from fat reduction.

[0005] Although various embodiments for aesthetic treatments are contemplated herein, the systems and procedures described herein are also used for non-aesthetic applications in some embodiments.

[0006] In various embodiments, an ultrasound system is configured for imaging to visualize tissue (e.g., dermal and subdermal layers of tissue) to ensure proper coupling of the transducer to the skin. In various embodiments, an ultrasound system is configured for imaging to visualize tissue (e.g., dermal and subdermal layers of tissue) to confirm appropriate depth of treatment such as to avoid certain tissues (e.g., bone).

[0007] In various embodiments, treating tissue, such as skin tissue, with multiple beams provides one or more advantages, such as, for example, reducing treatment time, creating unique heating patterns, leveraging multiple channels for greater power, the option to treat skin at two or more depths with the same or different power levels, (e.g., a thermal coagulation point in the superficial muscular aponeurotic system (“SMAS”) and another defocused energy at the surface of the skin, or other combinations), optional simultaneous treatment at different depths (e.g., such as at depths below a skin surface of 1.5 mm, 3 mm and/or 4.5 mm thermal coagulation points simultaneously or in an overlapping time period); and/or treatment with one, two, or more simultaneous linear or line focuses, such as at different depths below the skin surface or spaced apart. In some embodiments simultaneous multi-focus therapy uses dithering.

[0008] According to one embodiment, an ultrasound treatment system creates two or more simultaneous therapeutic treatment points and/or focal zones under the skin surface for a cosmetic treatment, wherein the treatment points are enlarged by dithering the ultrasound beams. In one embodiment, a focal zone is a point. In one embodiment, a focal zone is a line. In one embodiment, a focal zone is a plane. In one embodiment, a focal zone is

a three-dimensional volume or shape. The dithering of the ultrasound beam focus points enlarges the treatment area by shaking, blurring, or splattering the focus point or focus zone (e.g., a focus point, line, plane, or volume) like paint through an air brush by mechanically and/or electronically scattering the location of the focus points by varying the frequency, and therefore focal point, of the ultrasound treatment beams. In some embodiments, dithering increases efficacy by making a larger treatment points and/or focal zones. In some embodiments, dithering reduces pain since the temperature of the hot spot is spread over a larger volume of tissue, allowing a potential reduction in dose. In some embodiments, mechanical dithering is one method of spreading the acoustic energy from the ultrasound beam so there is less reliance on tissue thermal conduction away from the focus. In one embodiment of mechanical dithering, the therapy transducer is moved locally around the intended center of the thermal coagulation point (TCP). The acoustic beam movement can be side-to-side, up-down, and/or angular. In one embodiment of mechanical dithering, the movement of the motion mechanism is sufficiently fast enough to create a flatter temperature profile around the intended TCP which either allows a reduction of total acoustic energy for the same effected tissue volume or the same total acoustic energy for a larger effected tissue volume or any combination thereof.

[0009] In accordance with various embodiments, frequency modulation modifies the location of a focal zone and/or spacing between the focal zones, such that electronic dithering of beam via modulation of the frequency precisely alters and/or moves the position of the beam focus point(s). For example, in one embodiment, a spacing of 1.5 mm can be dithered with +/- 0.1 mm using a small frequency swing. In various embodiments, any one or more spacings of 0.5, 0.75, 1.0, 1.2, 1.5, 2.0 mm can be dithered with +/- 0.01, 0.05, 0.1, 0.12, 0.15, 0.20, 0.25, 0.30 mm using a frequency swing. In various embodiments, a frequency is modulated by 1 – 200% (e.g., 1%, 5%, 10%, 15%, 20%, 25%, 30%, 35%, 40%, 45%, 50%, 100%, 120%, 150%, 180%, 200% and any range therein).

[0010] Several embodiments relate to devices, systems and methods for providing one or more (e.g., a plurality or multiple) focus zones and/or ultrasound treatment points in performing various ultrasound treatment and/or imaging procedures quickly, safely, efficiently, and effectively. In some embodiments, no imaging is used. Some embodiments

relate to splitting an ultrasound therapy beam to two, three, four, or more focal zones from a single ultrasound transducer and/or single ultrasound transduction element. In some embodiments, multiple ultrasound beams are electronically manipulated with frequency modulation. In some embodiments, dithering (e.g., electronic dithering) of multiple and/or split ultrasound beam apertures using frequency modulation provide treatment zones or points in multiple locations. In some embodiments, dithering relates to intentional movement of the position/location of a focal point of an energy beam. For example, in one embodiment, dithering involves shaking, moving, vibrating, altering the location and/or position of a single focal zone, and/or a relative spacing between two or more focal zones. In various embodiments, the relative position of a focal zones is dithered by 1 – 50% (e.g., 1%, 5%, 10%, 15%, 20%, 25%, 30%, 35%, 40%, 45%, 50% and any range therein, such as a percentage of a mean location by a certain percentage). In various embodiments, spacing between focal zones is dithered by a range of between 1 – 50% (e.g., 1%, 5%, 10%, 15%, 20%, 25%, 30%, 35%, 40%, 45%, 50% and any range therein). In some embodiments, dithering may be achieved through mechanical, electronic, or combinations of mechanical and electronic means depending on the system design. In one embodiment of mechanical dithering, the ultrasound beam is moved locally around the intended TCP center through a mechanical translation or tilt of the therapy transducer or patient or any combination thereof. The mechanical translation and/or tilt enable(s) the spread of the acoustic energy such that thermal conduction limitations of tissue are overcome. This creates a flatter temperature profile in tissue to either reduce the total acoustic energy to create the same effected tissue volume or have the same total acoustic energy to increase the effected tissue volume when compared to a stationary ultrasound therapy device. In various embodiments of electronic dithering, frequency, phase, amplitude modulations or time based techniques are used to in combination with a uniquely defined transducer to move the ultrasound beam in tissue without any mechanical movement. In one embodiment, electronic movement of the ultrasound beam occurs significantly faster than mechanical movement to overcome the thermal conductivity limitation of tissue. In various embodiments, a ratio of relative focal zone positioning via dithering is 1:1000, 1:500, 1:200; 1:100, 1:50, 1:25, 1:10, 1:2 or any ratio between 1:1000 and 1:1. In various embodiments, a ratio of spacing between relative

focal zone positioning via dithering is 1:1000, 1:500, 1:200; 1:100, 1:50, 1:25, 1:10, 1:2 or any ratio between 1:1000 and 1:1. For example, in some embodiments, a focal zone is activated at “1” and an open spacing ratio of untreated tissue is provided in the second number of the ratio. For example, in one embodiment, a dithering spacing is e.g., 1 mm, and a dithering distance is 0.1 mm, so a ratio is 1:10. In various embodiments, a ratio of spacing between focal zones via dithering is 1:1000, 1:500, 1:200; 1:100, 1:50, 1:25, 1:10, 1:2 or any ratio between 1:1000 and 1:1. In some embodiments, the spacing of simultaneous focal zones is dithered. In some embodiments, the treatment points and/or zones are formed simultaneously in tissue. In various embodiments, dithering for performing various treatment and/or imaging procedures is with modulated and/or multiphased with controlled variance in frequency. Some embodiments relate to splitting an ultrasound therapy beam to two, three, four, or more focal zones for performing various treatment with, for example, dithering, poling, phasing, and/or modulation techniques and/or imaging procedures.

[0011] In several embodiments disclosed herein, non-invasive ultrasound systems are adapted to be used in achieving one or more of the following beneficial aesthetic and/or cosmetic improvement effects: a face lift, a brow lift, a chin lift, an eye treatment (e.g., malar bags, treat infraorbital laxity), a wrinkle reduction, fat reduction (e.g., treatment of adipose and/or cellulite), cellulite (which may be called gynoid lipodystrophy) treatment (e.g., dimple or non-dimple type female gynoid lipodystrophy), décolletage improvement (e.g., upper chest), a buttock lift (e.g., buttock tightening), skin tightening (for example, treating laxity to cause tightening on the face or body, such as the face, neck, chest, arms, thighs, abdomen, buttocks, etc.), a scar reduction (e.g., reduction of breast capsular fibrosis), a burn treatment, a tattoo removal, a vein removal, a vein reduction, a treatment on a sweat gland, a treatment of hyperhidrosis, a sun spot removal, an acne treatment, a pimple reduction. Several embodiments of the invention are particularly advantageous because they include one, several or all of the following benefits: faster treatment time, (ii) less pain during treatment, (iii) less pain after treatment, (iv) shorter recovery time, (v) more efficient treatment, (vi) higher customer satisfaction, (vii) less energy to complete a treatment, and/or (viii) larger treatment area by dithered focal regions. Various advantages of the embodiments of a simultaneous multiple depth treatment device configured to create multiple TCP's at various depths include

the creation of simultaneous TCPs at multiple depths. In one embodiment, an advantage is the elimination of multiple transducers, thereby reducing the transducer swapping by the operator. In one embodiment, an advantage is faster treatment time. In one embodiment, an advantage is fewer button presses deliver the same number of lines. In one embodiment, an advantage is modulation of the distance between the TCPs delivered simultaneously. In one embodiment, an advantage is maintaining the pitch separation of the TCPs at each depth along the line of mechanical motion. In one embodiment, an advantage is the avoidance of pulse stacking at multiple depths. In one embodiment, an advantage is the ability to create larger zones of coagulation and apoptosis. In one embodiment, an advantage is enabling the ability to deliver lines of microcoagulation along three dimensions. In one embodiment, an advantage of using an electrostrictor, includes creating more than two lines with one transducer placement on a patient's body. In one embodiment, an advantage of using an electrostrictor is modulating the distance between the simultaneously delivered TCPs. In one embodiment, an advantage is modulating the ability to mute spatial high frequency harmonics from the simultaneous therapy modulation pattern. In one embodiment, an advantage of using an electrostrictor offers the possibility of adding nulls to the modulation pattern. In one embodiment, an advantage of using an electrostrictor is to effectively modulate the distance between the simultaneously delivered TCPs while having electronic steering and focusing control on the opposite surface. This can be in the form of stripes orthogonal (or at any angle, e.g., 0 ° to 180 ° (5 °, 10 °, 15 °, 20 °, 30 °, 45 °, 60 °, 90 ° or more), with respect to each other) to the electrostrictor stripes, annular rings, and segments. In various embodiments, transducers are segmented. In various embodiments, a flat transducer can be focused with the use of a lens. In various embodiments, transducers are spherically focused to one or more points. In various embodiments, transducers are cylindrically focused to one or more lines.

[0012] In accordance with various embodiments, a cosmetic ultrasound treatment system and/or method can non-invasively produce single or multiple dithered cosmetic treatment zones and/or thermal coagulation points where ultrasound is focused in one or more locations in a region of treatment in tissue under a skin surface, and moved via changes in frequency (e.g., via frequency modulation). Some systems and methods provide cosmetic treatment at different locations in tissue, such as at different depths, heights, widths, and/or

positions. In one embodiment, a method and system comprise a multiple depth/height/width transducer system configured for providing ultrasound treatment to one or more region of interest, such as between at least one depth of treatment region of interest, a superficial region of interest, and/or a subcutaneous region of interest. In one embodiment, a method and system comprise a transducer system configured for providing ultrasound treatment to more than one region of interest, such as between at least two points in various locations (e.g. at one or more fixed or variable depths, heights, widths, and/or orientations, etc.) in a region of interest in tissue. Some embodiments can split a beam to focus at two, three, four, or more focal points (e.g., multiple focal points, multi-focal points) for cosmetic treatment zones and/or for imaging in a region of interest in tissue. Position and/or dithering of the focal points can be positioned axially, laterally, or otherwise within the tissue. Some embodiments can be configured for spatial control, such as by the location and/or dithering of a focus point, changing the distance from a transducer to a reflecting surface, and/or changing the angles of energy focused or unfocused to the region of interest, and/or configured for temporal control, such as by controlling changes in the frequency, drive amplitude and timing of the transducer. In some embodiments the position and/or dithering of multiple treatment zones or focal points is achieved with poling, phasic poling, biphasic poling, and/or multi-phasic poling. In some embodiments the position of multiple treatment zones or focal points with phasing, such as in one embodiment, electrical phasing. As a result, changes in the location of the treatment region, the number, shape, size and/or volume of treatment zones or lesions in a region of interest, as well as the thermal conditions, can be dynamically controlled over time.

[0013] In accordance with various embodiments, a cosmetic ultrasound treatment system and/or method can create multiple cosmetic treatment zones using one or more of frequency modulation, phase modulation, poling, nonlinear acoustics, and/or Fourier transforms to create any spatial periodic pattern with one or multiple ultrasound portions. In one embodiment, a system simultaneously or sequentially delivers single or multiple treatment zones using poling at a ceramic level. In one embodiment, a poling pattern is function of focal depth and frequency, and the use of odd or even functions. In one embodiment, a poling pattern, which can be a combination of odd or even functions, is applied, and based on focal depth and/or frequency. In one embodiment, a process can be

used in two or more dimensions to create any spatial periodic pattern. In one embodiment, an ultrasound beam is split axially and laterally to significantly reduce treatment time through the use of nonlinear acoustics and Fourier transforms. In one embodiment, modulation from a system and amplitude modulation from a ceramic or a transducer can be used to place multiple treatments zones in tissue, either sequentially or simultaneously.

[0014] In one embodiment, an aesthetic imaging and treatment system includes an ultrasonic probe that includes an ultrasound transducer configured to apply ultrasonic therapy to tissue at a plurality of locations at a focal depth with electronic dithering of multiple energy beam apertures with frequency modulation. In one embodiment, the system includes a control module coupled to the ultrasonic probe for controlling the ultrasound transducer.

[0015] In one embodiment, the system includes dithering configured to provide variable spacing between a plurality of individual cosmetic treatment zones. In one embodiment, a sequence of individual cosmetic treatment zones has a treatment spacing in a range from about 0.01 mm to about 25 mm (e.g., 1 mm, 1.5 mm, 2 mm, 2.5 mm, 3 mm, 5 mm, 10 mm, 20 mm and any value ranges therein), with a dithering alteration of the spacing by 1 – 50% (e.g., 1%, 5%, 10%, 15%, 20%, 25%, 30%, 35%, 40%, 45%, 50% and any range therein). In one embodiment, a sequence of individual cosmetic treatment zones has a treatment spacing in a range from about 0.01 mm to about 100 mm (e.g., 1 mm, 1.5 mm, 2 mm, 2.5 mm, 3 mm, 5 mm, 10 mm, 20 mm, 25 mm, 30 mm, 35 mm, 40 mm, 45 mm, 50 mm, 60 mm, 70 mm, 80 mm, 90 mm, and 100 mm, and any value ranges therein), with a dithering alteration of the spacing by 1 – 50% (e.g., 1%, 5%, 10%, 15%, 20%, 25%, 30%, 35%, 40%, 45%, 50% and any range therein).

[0016] In one embodiment, the system further includes a movement mechanism configured to be programmed to provide constant or variable spacing between the plurality of individual cosmetic treatment zones. In one embodiment, a sequence of individual cosmetic treatment zones has a treatment spacing in a range from about 0.01 mm to about 50 mm (e.g., 0.1, 0.5, 1, 2, 3, 4, 5, 6, 7, 8, 9, 10, 15, 19, 20, 25, 30, 35, 40, 45, 49 mm or any range or value therein). In one embodiment, a sequence of individual cosmetic treatment zones has a treatment spacing in a range from about 0.01 mm to about 100 mm (e.g., 0.1, 0.5, 1, 2, 3, 4, 5, 6, 7, 8, 9, 10, 15, 20, 25, 30, 35, 40, 50, 100 mm or any range or value therein). In one

embodiment, treatment zones are provided along a distance of about 25 mm. In one embodiment, treatment zones are provided along a distance of about 50 mm. In various embodiments, treatment zones are provided along a distance of 5 mm to 100 mm (e.g., 10 mm, 20 mm, 25 mm, 35 mm, 50 mm, 75 mm, 100 mm, and any amounts or ranges therein. In various embodiments, treatment zones are provided along a linear and/or curved distance.

[0017] For example, in some non-limiting embodiments transducers can be configured for a tissue depth of 0.5 mm, 1.0 mm, 1.5 mm, 2 mm, 3 mm, 4.5 mm, 6 mm, less than 3 mm, between 0.5 mm and 5 mm, between 1.5 mm and 4.5 mm, more than more than 4.5 mm, more than 6 mm, and anywhere in the ranges of 0.1 mm - 3 mm, 0.1 mm - 4.5 mm, 0.1 mm - 25 mm, 0.1 mm - 100 mm, and any depths therein (e.g., 6 mm, 10 mm, 13 mm, 15 mm, 17 mm). In several embodiments, tissue is treated at a depth below a skin surface and the skin surface is not impaired. Instead, the therapeutic effect achieved at the depth below the skin surface results in a favorable cosmetic appearance of the skin surface. In other embodiments, the skin surface is treated with ultrasound (e.g., at a depth less than 0.5 mm).

[0018] One benefit of a motion mechanism is that it can provide for a more efficient, accurate and precise use of an ultrasound transducer, for imaging and/or therapy purposes. One advantage this type of motion mechanism has over conventional fixed arrays of multiple transducers fixed in space in a housing is that the fixed arrays are a fixed distance apart. In one embodiment, the transducer module is configured to provide an acoustic power of the ultrasonic therapy in a range of between about 1 W to about 100 W or 100 W to 1000 W (e.g., 3-30 W, 7-30 W, 21-33 W, 200 W, 500 W, 750 W, 900 W) or more and a frequency of about 1 MHz to about 20 MHz to thermally heat the tissue to cause coagulation. In one embodiment, the transducer module is configured to provide an acoustic power of the ultrasonic therapy in a range of between about 1 W to about 500 W for peak or average energy, (e.g., 3-30 W, 7-30 W, 21-33 W, 100 W, 220 W, or more) and a frequency of about 1 MHz to about 20 MHz to thermally heat the tissue to cause coagulation. In some embodiments, an instantaneous energy is delivered. In some embodiments, an average energy is delivered. In one embodiment, the acoustic power can be from a range of 1 W to about 100 W in a frequency range from about 1 MHz to about 20 MHz (e.g., 1 MHz, 3 MHz, 4 MHz, 4.5 MHz, 7 MHz, 10 MHz, 2-12 MHz, 15 MHz, 18 MHz, 2 – 18 MHz), or from about 10 W

to about 50 W at a frequency range from about 3 MHz to about 8 MHz (e.g., 3 MHz, 4 MHz, 4.5 MHz, 7 MHz). In one embodiment, the acoustic power can be from a range of 1 W to about 500 W in a frequency range from about 1 MHz to about 12 MHz (e.g., 1 MHz, 4 MHz, 7 MHz, 10 MHz, 2-12 MHz), or from about 10 W to about 220 W at a frequency range from about 3 MHz to about 8 MHz, or 3 MHz to 10 MHz. In one embodiment, the acoustic power and frequencies are about 40 W at about 4.3 MHz and about 30 W at about 7.5 MHz. An acoustic energy produced by this acoustic power can be between about 0.01 joule ("J") to about 10 J or about 2 J to about 5 J. An acoustic energy produced by this acoustic power can be between about 0.01 J to about 60,000 J (e.g., via bulk heating, for body shaping, submental fat, abdomen and/or flanks, arms, inner thigh, outer thigh, buttocks, abdominal laxity, cellulite), about 10 J or about 2 J to about 5 J. In one embodiment, the acoustic energy is in a range less than about 3 J. In various embodiments, a treatment power is 1 kW/cm² to 100 kW/cm², 15 kW/cm² to 75 kW/cm², 1 kW/cm² to 5 kW/cm², 500 W/cm² to 10 kW/cm², 3 kW/cm² to 10 kW/cm², 15 kW/cm² to 50 kW/cm², 20 kW/cm² to 40 kW/cm², and/or 15 kW/cm² to 35 kW/cm².

[0019] In various embodiments, an ultrasound treatment system for dithering multiple simultaneous focus points from an ultrasound transducer includes an ultrasonic probe and a control module coupled to the ultrasonic probe for controlling the ultrasound transducer. The ultrasonic probe includes an ultrasound transducer with a single transduction element adapted to simultaneously apply ultrasonic therapy to tissue at a plurality of spaced locations at a focal depth. The ultrasound transducer is poled with at least a first poling configuration and a second poling configuration. The control module modifies the spacing between the spaced locations via dithering of a first focal zone and a second focal zone, such that dithering via modulation of a frequency precisely moves a position of a beam focus point at the spaced locations.

[0020] In one embodiment, the plurality of locations are positioned in a linear sequence within a cosmetic treatment zone, wherein the spaced locations are separated with a spacing dithered via a frequency swing. In one embodiment, a first set of locations is positioned within a first cosmetic treatment zone and a second set of locations is positioned within a second cosmetic treatment zone, the first zone being different from the second zone.

In one embodiment, the ultrasound transducer is adapted to apply ultrasonic therapy using amplitude modulation whereby a plurality of portions of the ultrasound transducer are adapted to emit ultrasonic therapy at a plurality of amplitudes of acoustic intensity, wherein a first amplitude is different than a second amplitude. In one embodiment, at least one portion of the ultrasonic transducer is adapted to emit ultrasonic therapy at two or more amplitudes of acoustic intensity, and wherein the amplitude of ultrasonic therapy emitted by the at least one portion of the piezoelectric varies over time. In one embodiment, the ultrasound transducer comprises piezoelectric material and the plurality of portions of the ultrasound transducer are adapted to create a plurality of corresponding piezoelectric material variations in response to an electric field applied to the ultrasound transducer. In one embodiment, the plurality of piezoelectric material variations comprise at least one of expansion of the piezoelectric material and contraction of the piezoelectric material. In one embodiment, the ultrasound transducer is adapted to apply ultrasonic therapy via phase shifting whereby a plurality of portions of the ultrasound transducer are adapted to emit ultrasonic therapy at a plurality of phases of acoustic intensity, wherein a first phase is different than a second phase. In one embodiment, the plurality of phases comprises discrete phase values. In one embodiment, the ultrasound transducer is adapted to apply ultrasonic therapy using amplitude modulation whereby a plurality of portions of the ultrasound transducer are adapted to emit ultrasonic therapy at a plurality of amplitudes of acoustic intensity, wherein a first amplitude is different than a second amplitude, and apply ultrasonic therapy whereby a plurality of portions of the ultrasound transducer are adapted to emit ultrasonic therapy at a plurality of phases of acoustic intensity, wherein a first phase is different than a second phase. Skin tightening by reducing skin laxity is accomplished in some embodiments to treat subject with excess or loose skin post weight loss, whether such weight loss occurs naturally or is performed surgically.

[0021] In various embodiments, an ultrasound treatment system for use in cosmetic treatment for dithering multiple simultaneous focal points from an ultrasound transducer includes an ultrasonic probe including a control module adapted to modify a spacing between a first focal zone and a second focal zone via dithering, a switch operably controlling an ultrasonic treatment function for providing an ultrasonic treatment, and a

movement mechanism adapted to direct ultrasonic treatment in at least one pair of simultaneous sequences of individual thermal cosmetic treatment zones, and a transducer module adapted to apply ultrasonic therapy. The transducer module is adapted for both ultrasonic imaging and ultrasonic treatment. The transducer module is adapted for coupling to the ultrasonic probe. The transducer module includes an ultrasound transducer adapted to apply ultrasonic therapy to tissue at a plurality of locations at a focal depth. The transducer module is adapted to be operably coupled to at least one of the switch and the movement mechanism. The control module includes a processor and a display for controlling the transducer module.

[0022] In one embodiment, the transducer module is adapted to apply ultrasonic therapy using amplitude modulation whereby a plurality of portions of the transducer module are adapted to emit ultrasonic therapy at a plurality of amplitudes of acoustic intensity, wherein a first amplitude is different than a second amplitude. In one embodiment, the transducer module is adapted to apply ultrasonic therapy whereby a plurality of portions of the transducer module are adapted to emit ultrasonic therapy at a plurality of phases of acoustic intensity, wherein a first phase is different than a second phase.

[0023] In various embodiments, an ultrasound treatment system for dithering multi-focus treatment includes a module comprising an ultrasound transducer. The ultrasound transducer is adapted to simultaneously apply ultrasonic therapy to tissue at a plurality of spaced locations in tissue, wherein the module modifies a spacing between the plurality of spaced locations via dithering of a first focal zone and a second focal zone, such that dithering via modulation of a frequency precisely moves a position of a beam focus point at the plurality of spaced locations, wherein the module further comprises an interface guide designed to for removable coupling to a hand wand to provide electronic communication and power between the module and the hand wand.

[0024] In one embodiment, the ultrasound transducer is adapted to apply ultrasonic therapy using amplitude modulation whereby a plurality of portions of the ultrasound transducer are adapted to emit ultrasonic therapy at a plurality of amplitudes of acoustic intensity, wherein a first amplitude is different than a second amplitude. In one embodiment, the ultrasound transducer is adapted to apply ultrasonic therapy whereby a

plurality of portions of the ultrasound transducer are adapted to emit ultrasonic therapy at a plurality of phases of acoustic intensity, wherein a first phase is different than a second phase. In one embodiment, the ultrasound transducer comprises piezoelectric material and the plurality of portions of the ultrasound transducer are adapted to create a plurality of corresponding piezoelectric material variations in response to an electric field applied to the ultrasound transducer. In one embodiment, at least one portion of the ultrasonic transducer is adapted to emit ultrasonic therapy at two or more amplitudes of acoustic intensity, and wherein the amplitude of ultrasonic therapy emitted by the at least one portion of the ultrasonic transducer remains constant over time. In one embodiment, the ultrasonic treatment is at least one of a face lift, a brow lift, a chin lift, an eye treatment (e.g., malar bags, treat infraorbital laxity), a wrinkle reduction, a décolletage improvement, a buttock lift, a scar reduction, a burn treatment, a tattoo removal, a skin tightening (e.g., abdominal laxity treatment or tightening of the skin on other areas of the body and face, such as any excess skin or tissue, such as during or after weight loss, such as, for example, the abdomen, buttocks, thighs, arms, and other areas), a vein removal, a vein reduction, a treatment on a sweat gland, a treatment of hyperhidrosis, a sun spot removal, a fat treatment, a vaginal rejuvenation, and an acne treatment.

[0025] In various embodiments, a method of dithering simultaneous focused ultrasound treatment beams includes providing an ultrasonic probe comprising an ultrasound transducer comprising a single transduction element adapted to simultaneously apply ultrasonic therapy to tissue at a plurality of spaced locations at a focal depth and a control module coupled to the ultrasonic probe for controlling the ultrasound transducer, and dithering the spacing between the spaced locations of a first focal zone and a second focal zone via modulation of a frequency to move a position of an ultrasound focus point at the spaced locations.

[0026] In one embodiment, the method includes imaging the first focal zone with an ultrasound imaging element. In one embodiment, the method includes imaging the second focal zone with an ultrasound imaging element. In one embodiment, the spacing between the first focal zone and the second focal zone is dithered in a range of between 1 – 50%. In one embodiment, the spacing between the first focal zone and the second focal zone is 1.5 mm

and is by 0.1 mm. In one embodiment, the modulation of frequency is in a range of between 1 – 50%.

[0027] In various embodiments, a method of dithering a focused ultrasound beam includes providing an ultrasonic probe comprising a single transduction element and a control module, wherein the single transduction element is adapted to apply ultrasonic therapy to tissue at a focal zone at a focal depth, wherein the control module is coupled to the ultrasonic probe for controlling the single transduction element, and dithering the focal zone via modulation of a frequency to alter a size of the focal zone at the tissue.

[0028] In one embodiment, the relative position of the focal zone is dithered in a range of between 1 – 50%. In one embodiment, a second focal zone is emitted simultaneously from the single transduction element. In one embodiment, the method includes imaging the focal zone with an ultrasound imaging element. In one embodiment, the modulation of the frequency is in a range of between 1 – 50%.

[0029] In various embodiments, an ultrasound treatment system for creating multiple focus points and different depths with an ultrasound transducer, includes an ultrasonic probe comprising an ultrasound transducer configured to apply ultrasonic therapy to tissue at a plurality of locations with at least two focal depths with at least one of the group consisting of amplitude modulation, poling and phase shifting, a movement mechanism configured to be programmed to provide spacing between the plurality of individual cosmetic treatment zones; wherein the wherein a sequence of individual cosmetic treatment zones has a treatment spacing in a range from 1 mm to 50 mm and a control module coupled to the ultrasonic probe for controlling the ultrasound transducer, wherein the ultrasonic transducer is configured to provide an acoustic power of the ultrasonic therapy in a range of between 10W to 1000W and a frequency of 1 MHz to 20 MHz to thermally heat the tissue to cause coagulation. In one embodiment, the plurality of locations are positioned in a substantially linear sequence within a cosmetic treatment zone and the ultrasound transducer comprises a single ultrasound transduction element. In one embodiment, a first set of locations is positioned within a first cosmetic treatment zone and a second set of locations is positioned within a second cosmetic treatment zone, the first zone being different from the second zone. In one embodiment, the first cosmetic treatment zone comprises a substantially linear

sequence of the first set of locations and the second cosmetic treatment zone comprises a substantially linear sequence of the second set of locations. In one embodiment, the ultrasound transducer is configured to apply ultrasonic therapy using amplitude modulation whereby a plurality of portions of the ultrasound transducer are configured to emit ultrasonic therapy at a plurality of amplitudes of acoustic intensity, wherein a first amplitude is different than a second amplitude.

[0030] In one embodiment, the ultrasound transducer is configured to apply ultrasonic therapy phase shifting whereby a plurality of portions of the ultrasound transducer are configured to emit ultrasonic therapy at a plurality of phases of acoustic intensity, wherein a first phase is different than a second phase. In one embodiment, the ultrasound transducer is configured to apply ultrasonic therapy using amplitude modulation whereby a plurality of portions of the ultrasound transducer are configured to emit ultrasonic therapy at a plurality of amplitudes of acoustic intensity, wherein a first amplitude is different than a second amplitude; and apply ultrasonic therapy phase shifting whereby a plurality of portions of the ultrasound transducer are configured to emit ultrasonic therapy at a plurality of phases of acoustic intensity, wherein a first phase is different than a second phase. In one embodiment, the plurality of phases comprises discrete phase values. In one embodiment, the ultrasound transducer comprises piezoelectric material and the plurality of portions of the ultrasound transducer are configured to create a plurality of corresponding piezoelectric material variations in response to an electric field applied to the ultrasound transducer. In one embodiment, the plurality of piezoelectric material variations comprise at least one of expansion of the piezoelectric material and contraction of the piezoelectric material. In one embodiment, at least one portion of the ultrasonic transducer is configured to emit ultrasonic therapy at two or more amplitudes of acoustic intensity, and wherein the amplitude of ultrasonic therapy emitted by the at least one portion of the piezoelectric varies over time. In one embodiment, the movement mechanism is configured to be programmed to provide variable spacing between the plurality of individual cosmetic treatment zones, further comprising one or more selectable tuning circuits. In one embodiment, a sequence of individual cosmetic treatment zones has a treatment spacing in a range from 1 mm to 25 mm, further comprising a tuning circuit. In one embodiment, the ultrasonic treatment is at least

one of a face lift, a brow lift, a chin lift, an eye treatment, a wrinkle reduction, a scar reduction, a burn treatment, a skin tightening, a vein reduction, a treatment on a sweat gland, a treatment of hyperhidrosis, a sun spot removal, a fat treatment, a cellulite treatment, a décolletage treatment, a vaginal rejuvenation, and an acne treatment. In one embodiment, the ultrasonic transducer is configured to provide an acoustic power of the ultrasonic therapy in a range of between 10W to 100W and a frequency of 1 MHz to 12 MHz to thermally heat the tissue to cause coagulation.

[0031] In various embodiments, treatment system for creating multiple focal points simultaneously at different depths with an ultrasound transducer, the system including an ultrasonic probe with a first switch operably controlling an ultrasonic imaging function for providing an ultrasonic imaging, a second switch operably controlling an ultrasonic treatment function for providing an ultrasonic treatment, and a movement mechanism configured to direct ultrasonic treatment in at least one sequence of individual thermal cosmetic treatment zones, and a transducer module configured to apply ultrasonic therapy with at least one of the group consisting of amplitude modulation, poling and phase shifting, wherein the transducer module is configured for both ultrasonic imaging and ultrasonic treatment, wherein the transducer module is configured for coupling to the ultrasonic probe, wherein the transducer module comprises an ultrasound transducer configured to apply ultrasonic therapy to tissue at a plurality of locations with at least two focal depths, wherein the transducer module is configured to be operably coupled to at least one of the first switch, the second switch and the movement mechanism; and a control module, wherein the control module comprises a processor and a display for controlling the transducer module.

[0032] In one embodiment, the ultrasonic treatment is a cosmetic treatment, wherein the plurality of locations are positioned in a substantially linear sequence within a cosmetic treatment zone. In one embodiment, the ultrasonic treatment is an aesthetic treatment, wherein a first set of locations is positioned within a first treatment zone and a second set of locations is positioned within a second treatment zone, the first zone being different from the second zone. In one embodiment, the first treatment zone comprises a substantially linear sequence of the first set of locations and the second treatment zone comprises a substantially linear sequence of the second set of locations. In one embodiment,

the transducer module is configured to apply ultrasonic therapy using amplitude modulation whereby a plurality of portions of the transducer module are configured to emit ultrasonic therapy at a plurality of amplitudes of acoustic intensity, wherein a first amplitude is different than a second amplitude. In one embodiment, the transducer module is configured to apply ultrasonic therapy phase shifting whereby a plurality of portions of the transducer module are configured to emit ultrasonic therapy at a plurality of phases of acoustic intensity, wherein a first phase is different than a second phase. In one embodiment, the transducer module is configured to apply ultrasonic therapy using amplitude modulation whereby a plurality of portions of the transducer module are configured to emit ultrasonic therapy at a plurality of amplitudes of acoustic intensity, wherein a first amplitude is different than a second amplitude; and apply ultrasonic therapy phase shifting whereby a plurality of portions of the transducer module are configured to emit ultrasonic therapy at a plurality of phases of acoustic intensity, wherein a first phase is different than a second phase. In one embodiment, the plurality of phases comprises discrete phase values. In one embodiment, the transducer module comprises piezoelectric material and the plurality of portions of the transducer module are configured to create a plurality of corresponding piezoelectric material variations in response to an electric field applied to the transducer module. In one embodiment, the plurality of piezoelectric material variations comprise at least one of expansion of the material and contraction of the material. In one embodiment, at least one portion of the transducer module is configured to emit ultrasonic therapy at two or more amplitudes of acoustic intensity, and wherein the amplitude of ultrasonic therapy emitted by the at least one portion of the transducer module varies over time. In one embodiment, the movement mechanism is configured to be programmed to provide variable spacing between a plurality of individual thermal cosmetic treatment zones. In one embodiment, a sequence of individual thermal cosmetic treatment zones has a treatment spacing in a range from 1 mm to 25 mm. In one embodiment, the first and second switches comprises user operated buttons or keys. In one embodiment, at least one of the first switch and the second switch is activated by the control module. In one embodiment, the treatment function is at least one of a face lift, a brow lift, a chin lift, an eye treatment, a wrinkle reduction, a scar reduction, a burn treatment, a tattoo removal, a skin tightening, a vein removal, a vein reduction, a treatment on a sweat

gland, a treatment of hyperhidrosis, a sun spot removal, a fat treatment, a cellulite treatment, a décolletage treatment, a vaginal rejuvenation, and an acne treatment. In one embodiment, the transducer module is configured to provide an acoustic power of the ultrasonic therapy in a range of between 10 W to 1000W and a frequency of 1 MHz to 20 MHz to thermally heat the tissue to cause coagulation.

[0033] In various embodiments, a treatment system for delivering simultaneous treatment at multiple depths, the system including a controlling device operably controlling an ultrasonic treatment function for providing an ultrasonic treatment; and a hand wand configured to direct ultrasonic treatment in a sequence of individual thermal cosmetic treatment zones, the hand wand including a transducer configured to apply ultrasonic therapy to tissue at a location at a focal depth, the location positioned within a thermal cosmetic treatment zone, wherein the transducer is further configured to simultaneously apply ultrasonic therapy to tissue at a plurality of locations at the focal depth.

[0034] In various embodiments, a method of performing a noninvasive cosmetic procedure on the skin by creating multiple simultaneous focal points at multiple depths with a single transducer, the method including coupling a transducer module with an ultrasonic probe; wherein the ultrasonic probe comprises a first switch to control acoustic imaging; wherein the ultrasonic probe comprises a second switch to control acoustic therapy for causing a plurality of individual cosmetic treatment zones; wherein the ultrasonic probe comprises a movement mechanism to provide desired spacing between the individual cosmetic treatment zones; contacting the transducer module with a subject's skin surface; activating the first switch on the ultrasonic probe to acoustically image, with the transducer module, a region below the skin surface; and activating the second switch on the ultrasonic probe to acoustically treat, with the transducer module, the region below the skin surface in a desired sequence of individual cosmetic treatment zones that is controlled by the movement mechanism, wherein the transducer module comprises a single ultrasound transducer configured to apply ultrasonic therapy to tissue at a plurality of focal depths.

[0035] In various embodiments, an ultrasound treatment system for creating multiple focal points simultaneously at multiple depths in tissue with an ultrasound transducer, the system including a controlling device operably controlling an ultrasonic

treatment function for providing an ultrasonic treatment; and a hand wand configured to direct ultrasonic treatment in a sequence of individual thermal cosmetic treatment zones, the hand wand comprising: a transducer configured to apply ultrasonic therapy to tissue at a plurality of locations at a focal depth.

[0036] In various embodiments, an imaging and treatment system for use in cosmetic treatment at multiple depths in tissue, the system including an ultrasonic probe configured for ultrasonic imaging and ultrasonic treatment of tissue at a plurality of focal depths, including a transducer module configured for coupling to the ultrasonic probe, wherein the transducer module comprises an ultrasound transducer configured to apply an ultrasonic therapy to tissue at the plurality of locations at the focal depth, a first switch operably controlling an ultrasonic imaging function for providing an ultrasonic imaging; a second switch operably controlling an ultrasonic treatment function for providing the ultrasonic therapy; and a movement mechanism configured to direct ultrasonic treatment in at least one sequence of individual thermal cosmetic treatment zones; and wherein the transducer module is configured to be operably coupled to at least one of the first switch, the second switch and the movement mechanism; and a control module, wherein the control module comprises a processor and a display for controlling the transducer module.

[0037] In one embodiment, the plurality of locations are positioned in a substantially linear sequence within a cosmetic treatment zone. In one embodiment, a first set of locations is positioned within a first cosmetic treatment zone and a second set of locations is positioned within a second cosmetic treatment zone, the first zone being different from the second zone. In one embodiment, the first cosmetic treatment zone comprises a substantially linear sequence of the first set of locations and the second cosmetic treatment zone comprises a substantially linear sequence of the second set of locations. In one embodiment, the transducer module is configured to apply ultrasonic therapy using amplitude modulation whereby a plurality of portions of the transducer module are configured to emit ultrasonic therapy at a plurality of amplitudes of acoustic intensity, wherein a first amplitude is different than a second amplitude. In one embodiment, the transducer module is configured to apply ultrasonic therapy phase shifting whereby a plurality of portions of the transducer module are configured to emit ultrasonic therapy at a plurality of phases of acoustic intensity, wherein a

first phase is different than a second phase. In one embodiment, the transducer module is configured to apply ultrasonic therapy using amplitude modulation whereby a plurality of portions of the transducer module are configured to emit ultrasonic therapy at a plurality of amplitudes of acoustic intensity, wherein a first amplitude is different than a second amplitude; and apply ultrasonic therapy phase shifting whereby a plurality of portions of the transducer module are configured to emit ultrasonic therapy at a plurality of phases of acoustic intensity, wherein a first phase is different than a second phase. In one embodiment, the plurality of phases comprises discrete phase values. In one embodiment, the transducer module comprises piezoelectric material and the plurality of portions of the transducer module are configured to create a plurality of corresponding piezoelectric material variations in response to an electric field applied to the transducer module. In one embodiment, the plurality of piezoelectric material variations comprise at least one of expansion of the material and contraction of the material. In one embodiment, at least one portion of the transducer module is configured to emit ultrasonic therapy at two or more amplitudes of acoustic intensity, and wherein the amplitude of ultrasonic therapy emitted by the at least one portion of the transducer module varies over time. In one embodiment, the movement mechanism is configured to be programmed to provide variable spacing between a plurality of individual thermal cosmetic treatment zones. In one embodiment, a sequence of individual thermal cosmetic treatment zones has a treatment spacing in a range from 0.01 mm to 25 mm. In one embodiment, the first and second switches comprises user operated buttons or keys. In one embodiment, at least one of the first switch and the second switch is activated by the control module. In one embodiment, the treatment function is at least one of a face lift, a brow lift, a chin lift, an eye treatment, a wrinkle reduction, a scar reduction, a burn treatment, a tattoo removal, a skin tightening, a vein removal, a vein reduction, a treatment on a sweat gland, a treatment of hyperhidrosis, a sun spot removal, a fat treatment, a vaginal rejuvenation, and an acne treatment. In one embodiment, the transducer module is configured to provide an acoustic power of the ultrasonic therapy in a range of between 10W to 1000W and a frequency of 1 MHz to 10 MHz to thermally heat the tissue to cause coagulation.

[0038] In various embodiments, a multi-focus ultrasound treatment system for simultaneous treatment at multiple depths, the system including a controlling device operably

controlling an ultrasonic treatment function for providing an ultrasonic treatment; and a hand wand configured to direct ultrasonic treatment in a sequence of individual thermal cosmetic treatment zones, the hand wand including a transducer configured to apply ultrasonic therapy to tissue at a location at a focal depth, the location positioned within a thermal cosmetic treatment zone, wherein the transducer is further configured to apply ultrasonic therapy to tissue simultaneously at a plurality of locations at the focal depth.

[0039] In various embodiments, an imaging and simultaneous multi-focus treatment system at multiple depths including a module comprising an ultrasound transducer, wherein the ultrasound transducer is configured to apply ultrasonic therapy to tissue at a plurality of focal depths with at least one of the group consisting of amplitude modulation, poling and phase shifting, wherein the module further comprises an interface guide designed to for removable coupling to a hand wand to provide electronic communication and power between the module and the hand wand.

[0040] In one embodiment, the plurality of locations are positioned in a substantially linear sequence within a cosmetic treatment zone. In one embodiment, a first set of locations is positioned within a first cosmetic treatment zone and a second set of locations is positioned within a second cosmetic treatment zone, the first zone being different from the second zone. In one embodiment, the first cosmetic treatment zone comprises a substantially linear sequence of the first set of locations and the second cosmetic treatment zone comprises a substantially linear sequence of the second set of locations. In one embodiment, the ultrasound transducer is configured to apply ultrasonic therapy using amplitude modulation whereby a plurality of portions of the ultrasound transducer are configured to emit ultrasonic therapy at a plurality of amplitudes of acoustic intensity, wherein a first amplitude is different than a second amplitude. In one embodiment, the ultrasound transducer is configured to apply ultrasonic therapy phase shifting whereby a plurality of portions of the ultrasound transducer are configured to emit ultrasonic therapy at a plurality of phases of acoustic intensity, wherein a first phase is different than a second phase. In one embodiment, the ultrasound transducer is configured to apply ultrasonic therapy using amplitude modulation whereby a plurality of portions of the ultrasound transducer are configured to emit ultrasonic therapy at a plurality of amplitudes of acoustic intensity, wherein a first amplitude is different than a second

amplitude; and apply ultrasonic therapy phase shifting whereby a plurality of portions of the ultrasound transducer are configured to emit ultrasonic therapy at a plurality of phases of acoustic intensity, wherein a first phase is different than a second phase. In one embodiment, the plurality of phases comprises discrete phase values. In one embodiment, the ultrasound transducer comprises piezoelectric material and the plurality of portions of the ultrasound transducer are configured to create a plurality of corresponding piezoelectric material variations in response to an electric field applied to the ultrasound transducer. In one embodiment, the plurality of piezoelectric material variations comprise at least one of expansion of the piezoelectric material and contraction of the piezoelectric material. In one embodiment, at least one portion of the ultrasonic transducer is configured to emit ultrasonic therapy at two or more amplitudes of acoustic intensity, and wherein the amplitude of ultrasonic therapy emitted by the at least one portion of the piezoelectric varies over time. In one embodiment, the imaging and treatment system includes a movement mechanism configured to be programmed to provide spacing between the plurality of individual cosmetic treatment zones. In one embodiment, a sequence of individual cosmetic treatment zones has a treatment spacing in a range from 1 mm to 50 mm. In one embodiment, the ultrasonic treatment is at least one of a face lift, a brow lift, a chin lift, an eye treatment, a wrinkle reduction, a scar reduction, a burn treatment, a tattoo removal, a skin tightening, a vein removal, a vein reduction, a treatment on a sweat gland, a treatment of hyperhidrosis, a sun spot removal, a fat treatment, a vaginal rejuvenation, and an acne treatment. In one embodiment, the ultrasonic transducer is configured to provide an acoustic power of the ultrasonic therapy in a range of between 1W to 100W and a frequency of 1 MHz to 10 MHz to thermally heat the tissue to cause coagulation.

[0041] In various embodiments, a treatment system for simultaneous treatment at multiple depths, the system comprising: a controlling device operably controlling an ultrasonic treatment function for providing an ultrasonic treatment; and a hand wand configured to direct ultrasonic treatment in a sequence of individual thermal cosmetic treatment zones, the hand wand including a transducer configured to simultaneously apply ultrasonic therapy to tissue at a plurality of locations at a focal depth.

[0042] In various embodiments, a non-invasive method of simultaneously performing a cosmetic procedure at multiple depths that is not performed by a doctor, the method including coupling a transducer module with an ultrasonic probe; wherein the transducer module comprises an ultrasound transducer configured to apply ultrasonic therapy to tissue at a plurality of locations at a focal depth with at least one of the group consisting of amplitude modulation, poling and phase shifting, wherein the ultrasonic probe comprises a first switch to control acoustic imaging; wherein the ultrasonic probe comprises a second switch to control acoustic therapy for causing a plurality of individual cosmetic treatment zones; wherein the ultrasonic probe comprises a movement mechanism to provide desired spacing between the individual cosmetic treatment zones; contacting the transducer module with a subject's skin surface; activating the first switch on the ultrasonic probe to acoustically image, with the transducer module, a region below the skin surface; and activating the second switch on the ultrasonic probe to acoustically treat, with the transducer module, the region below the skin surface in a desired sequence of individual cosmetic treatment zones that is controlled by the movement mechanism.

[0043] In various embodiments, an ultrasound treatment system for dithering multiple simultaneous focus points from an ultrasound transducer at multiple depths includes an ultrasonic probe comprising an ultrasound transducer with a single transduction element adapted to simultaneously apply ultrasonic therapy to tissue at a plurality of spaced focal depths, wherein the ultrasound transducer is poled with at least a first poling configuration and a second poling configuration, a control module coupled to the ultrasonic probe for controlling the ultrasound transducer, wherein the control module modifies the spacing between the spaced locations via dithering of a first focal zone and a second focal zone, such that dithering via modulation of a frequency precisely moves a position of a beam focus point at the spaced locations.

[0044] In one embodiment, the plurality of locations are positioned in a linear sequence within a cosmetic treatment zone, wherein the spaced locations are separated with a spacing dithered via a frequency swing. In one embodiment, a first set of locations is positioned within a first cosmetic treatment zone and a second set of locations is positioned within a second cosmetic treatment zone, the first zone being different from the second zone.

In one embodiment, the ultrasound transducer is adapted to apply ultrasonic therapy using amplitude modulation whereby a plurality of portions of the ultrasound transducer are adapted to emit ultrasonic therapy at a plurality of amplitudes of acoustic intensity, wherein a first amplitude is different than a second amplitude. In one embodiment, at least one portion of the ultrasonic transducer is adapted to emit ultrasonic therapy at two or more amplitudes of acoustic intensity, and wherein the amplitude of ultrasonic therapy emitted by the at least one portion of the piezoelectric varies over time. In one embodiment, the ultrasound transducer comprises piezoelectric material and the plurality of portions of the ultrasound transducer are adapted to create a plurality of corresponding piezoelectric material variations in response to an electric field applied to the ultrasound transducer. In one embodiment, the plurality of piezoelectric material variations comprise at least one of expansion of the piezoelectric material and contraction of the piezoelectric material. In one embodiment, the ultrasound transducer is adapted to apply ultrasonic therapy via phase shifting whereby a plurality of portions of the ultrasound transducer are adapted to emit ultrasonic therapy at a plurality of phases of acoustic intensity, wherein a first phase is different than a second phase. In one embodiment, the plurality of phases comprises discrete phase values. In one embodiment, the ultrasound transducer is adapted to apply ultrasonic therapy using amplitude modulation whereby a plurality of portions of the ultrasound transducer are adapted to emit ultrasonic therapy at a plurality of amplitudes of acoustic intensity, wherein a first amplitude is different than a second amplitude; and apply ultrasonic therapy whereby a plurality of portions of the ultrasound transducer are adapted to emit ultrasonic therapy at a plurality of phases of acoustic intensity, wherein a first phase is different than a second phase. In one embodiment, the ultrasonic treatment is at least one of: a face lift, a brow lift, a chin lift, an eye treatment, a wrinkle reduction, a décolletage improvement, a buttock lift, a scar reduction, a burn treatment, a skin tightening, a blood vessel reduction, a treatment of a sweat gland, a sun spot removal, a fat treatment, an abdominal laxity treatment, and a cellulite treatment. In one embodiment, the ultrasonic probe comprises a movement mechanism adapted to direct ultrasonic treatment in at least one pair of simultaneous sequences of individual thermal cosmetic treatment zones. In one embodiment, the ultrasonic probe is configured for both

ultrasonic imaging and ultrasonic treatment. In one embodiment, the ultrasonic probe comprises a transducer module adapted to apply ultrasonic therapy.

[0045] In various embodiments, an ultrasound treatment system for use in cosmetic treatment for dithering multiple simultaneous focal points at multiple depths from an ultrasound transducer, the system including an ultrasonic probe with a control module adapted to modify a spacing between a first focal zone and a second focal zone via dithering, a switch operably controlling an ultrasonic treatment function for providing an ultrasonic treatment; and a movement mechanism adapted to direct ultrasonic treatment in at least one pair of simultaneous sequences of individual thermal cosmetic treatment zones; and a transducer module adapted to apply ultrasonic therapy, wherein the transducer module is adapted for both ultrasonic imaging and ultrasonic treatment, wherein the transducer module is adapted for coupling to the ultrasonic probe, wherein the transducer module comprises an ultrasound transducer adapted to apply ultrasonic therapy to tissue at a plurality of locations with at least two focal depths, wherein the transducer module is adapted to be operably coupled to at least one of the switch and the movement mechanism; and wherein the control module comprises a processor and a display for controlling the transducer module.

[0046] In one embodiment, the transducer module is adapted to apply ultrasonic therapy using amplitude modulation whereby a plurality of portions of the transducer module are adapted to emit ultrasonic therapy at a plurality of amplitudes of acoustic intensity, wherein a first amplitude is different than a second amplitude. In one embodiment, the transducer module is adapted to apply ultrasonic therapy whereby a plurality of portions of the transducer module are adapted to emit ultrasonic therapy at a plurality of phases of acoustic intensity, wherein a first phase is different than a second phase.

[0047] In various embodiments, an ultrasound treatment system for dithering simultaneous multi-focus treatment at a plurality of depths includes a module comprising an ultrasound transducer, wherein the ultrasound transducer is adapted to simultaneously apply ultrasonic therapy to tissue at a plurality of spaced depths in tissue, wherein the module modifies a spacing between the plurality of spaced depths via dithering of a first focal zone and a second focal zone, such that dithering via modulation of a frequency precisely moves a position of a beam focus point at the plurality of spaced depths, wherein the module further

comprises an interface guide designed to for removable coupling to a hand wand to provide electronic communication and power between the module and the hand wand.

[0048] In one embodiment, the ultrasound transducer is adapted to apply ultrasonic therapy using amplitude modulation whereby a plurality of portions of the ultrasound transducer are adapted to emit ultrasonic therapy at a plurality of amplitudes of acoustic intensity, wherein a first amplitude is different than a second amplitude. In one embodiment, the ultrasound transducer is adapted to apply ultrasonic therapy whereby a plurality of portions of the ultrasound transducer are adapted to emit ultrasonic therapy at a plurality of phases of acoustic intensity, wherein a first phase is different than a second phase. In one embodiment, the ultrasound transducer comprises piezoelectric material and the plurality of portions of the ultrasound transducer are adapted to create a plurality of corresponding piezoelectric material variations in response to an electric field applied to the ultrasound transducer. In one embodiment, at least one portion of the ultrasonic transducer is adapted to emit ultrasonic therapy at two or more amplitudes of acoustic intensity, and wherein the amplitude of ultrasonic therapy emitted by the at least one portion of the ultrasonic transducer remains constant over time. In one embodiment, the ultrasonic treatment is at least one of a face lift, a brow lift, a chin lift, an eye treatment, a wrinkle reduction, a décolletage improvement, a buttock lift, a scar reduction, a burn treatment, a tattoo removal, a skin tightening, a vein removal, a vein reduction, a treatment on a sweat gland, a treatment of hyperhidrosis, a sun spot removal, a fat treatment, a cellulite treatment, an abdominal laxity treatment, a vaginal rejuvenation, and an acne treatment.

[0049] In various embodiments, a method of dithering simultaneous focused ultrasound treatment beams at a plurality of depths, includes providing an ultrasonic probe comprising an ultrasound transducer comprising a single transduction element adapted to simultaneously apply ultrasonic therapy to tissue at a plurality of spaced locations at a plurality of focal depths and a control module coupled to the ultrasonic probe for controlling the ultrasound transducer, and dithering the spacing between the spaced locations of a first focal zone and a second focal zone via modulation of a frequency to move a position of an ultrasound focus point at the spaced locations.

[0050] In one embodiment, the method further includes imaging the first focal zone with an ultrasound imaging element. In one embodiment, the method further includes imaging the second focal zone with an ultrasound imaging element. In one embodiment, the spacing between the first focal zone and the second focal zone is dithered in a range of between 1 – 50%. In one embodiment, the spacing between the first focal zone and the second focal zone is 1.5 mm and is by 0.1 mm. In one embodiment, the modulation of frequency is in a range of between 1 – 50%. In one embodiment, the ultrasound treatment is at least one of a face lift, a brow lift, a chin lift, an eye treatment, a wrinkle reduction, a décolletage improvement, a buttock lift, a scar reduction, a burn treatment, a tattoo removal, a skin tightening, a vein removal, a vein reduction, a treatment on a sweat gland, a treatment of hyperhidrosis, a sun spot removal, a fat treatment, a vaginal rejuvenation, a treatment for abdominal laxity, and an acne treatment.

[0051] In various embodiments, a method of simultaneously dithering a focused ultrasound beam at multiple depths including providing an ultrasonic probe comprising a single transduction element and a control module, wherein the single transduction element is adapted to apply ultrasonic therapy to tissue at a focal zone at a focal depth, wherein the control module is coupled to the ultrasonic probe for controlling the single transduction element, and dithering the focal zone via modulation of a frequency to alter a size of the focal zone at the tissue.

[0052] In one embodiment, the relative position of the focal zone is dithered in a range of between 1 – 50%. In one embodiment, a second focal zone is emitted simultaneously from the single transduction element. In one embodiment, the modulation of the frequency is in a range of between 1 – 50%. In one embodiment, the system is designed to work non-invasively to treat tissue. In one embodiment, the method functions in a non-invasive manner to treat tissue.

[0053] In various embodiments, an ultrasound treatment system for delivering simultaneous multi-focus treatment at a plurality of depths with an electrostrictor including a module comprising an ultrasound transducer, wherein the ultrasound transducer is adapted to simultaneously apply ultrasonic therapy to tissue at a plurality of spaced depths in tissue with the application of an electrostrictor, wherein the module modifies a spacing between the

plurality of spaced depths via dithering of a first focal zone and a second focal zone, such that dithering via modulation of a frequency precisely moves a position of a beam focus point at the plurality of spaced depths, wherein the module further comprises an interface guide designed to for removable coupling to a hand wand to provide electronic communication and power between the module and the hand wand.

[0054] In one embodiment, the ultrasound transducer is adapted to apply ultrasonic therapy using amplitude modulation whereby a plurality of portions of the ultrasound transducer are adapted to emit ultrasonic therapy at a plurality of amplitudes of acoustic intensity, wherein a first amplitude is different than a second amplitude. In one embodiment, the ultrasound transducer is adapted to apply ultrasonic therapy whereby a plurality of portions of the ultrasound transducer are adapted to emit ultrasonic therapy at a plurality of phases of acoustic intensity, wherein a first phase is different than a second phase. In one embodiment, the ultrasound transducer comprises piezoelectric material and the plurality of portions of the ultrasound transducer are adapted to create a plurality of corresponding piezoelectric material variations in response to an electric field applied to the ultrasound transducer. In one embodiment, at least one portion of the ultrasonic transducer is adapted to emit ultrasonic therapy at two or more amplitudes of acoustic intensity, and wherein the amplitude of ultrasonic therapy emitted by the at least one portion of the ultrasonic transducer remains constant over time. In one embodiment, the ultrasonic treatment is at least one of a face lift, a brow lift, a chin lift, an eye treatment, a wrinkle reduction, a décolletage improvement, a buttock lift, a scar reduction, a burn treatment, a tattoo removal, a skin tightening, a vein removal, a vein reduction, a treatment on a sweat gland, a treatment of hyperhidrosis, a sun spot removal, a fat treatment, a cellulite treatment, an abdominal laxity treatment, a vaginal rejuvenation, and an acne treatment.

[0055] In various embodiments, provided is an ultrasound treatment system having one or more of the features described in the description. In various embodiments, provided is a method of reducing imaging misalignment in a moving ultrasound transducer having one or more of the features described in the description. In various embodiments, provided is an ultrasound treatment system for producing multiple simultaneous focus points from an ultrasound transducer having one or more of the features described in the description.

In various embodiments, provided is an ultrasound treatment system for delivering multi-focus treatment having one or more of the features described in the description. In various embodiments, provided is an ultrasound treatment module for use in cosmetic treatment for forming multiple simultaneous focal zones from an ultrasound transducer having one or more of the features described in the description. In various embodiments, provided is a method of generating simultaneous focused ultrasound treatment beams using multi-channel signal mixing having one or more of the features described in the description. In various embodiments, provided is a method of generating simultaneous focused ultrasound beams having one or more of the features described in the description.

[0056] In several of the embodiments described herein, the procedure is entirely cosmetic and not a medical act. For example, in one embodiment, the methods described herein need not be performed by a doctor, but at a spa or other aesthetic institute. In some embodiments, a system can be used for the non-invasive cosmetic treatment of skin.

[0057] The methods summarized above and set forth in further detail below describe certain actions taken by a practitioner; however, it should be understood that they can also include the instruction of those actions by another party. Thus, actions such as “dithering an energy beam” include “instructing the dithering of an energy beam.”

[0058] In some embodiments, the system comprises various features that are present as single features (as opposed to multiple features). For example, in one embodiment, the system includes a single transduction element that produces two simultaneous treatment focus points that are dithered. Multiple features or components are provided in alternate embodiments. In various embodiments, the system comprises, consists essentially of, or consists of one, two, three, or more embodiments of any features or components disclosed herein. In some embodiments, a feature or component is not included and can be negatively disclaimed from a specific claim, such that the system is without such feature or component.

[0059] Further, areas of applicability will become apparent from the description provided herein. It should be understood that the description and specific examples are intended for purposes of illustration only and are not intended to limit the scope of the embodiments disclosed herein.

BRIEF DESCRIPTION OF THE DRAWINGS

[0060] The drawings described herein are for illustration purposes only and are not intended to limit the scope of the present disclosure in any way. Embodiments of the present invention will become more fully understood from the detailed description and the accompanying drawings wherein:

[0061] FIG. 1A is a schematic illustration of an ultrasound system according to various embodiments of the present invention.

[0062] FIG. 1B is a schematic illustration of an ultrasound system according to various embodiments of the present invention.

[0063] FIG. 1C is a schematic illustration of an ultrasound system according to various embodiments of the present invention.

[0064] FIG. 2 is a schematic illustration of an ultrasound system coupled to a region of interest according to various embodiments of the present invention.

[0065] FIG. 3 is a schematic illustration of a portion of a transducer according to various embodiments of the present invention.

[0066] FIG. 4 is a partial cut away side view of an ultrasound system according to various embodiments of the present invention.

[0067] FIG. 5 is table illustrating foci separation for apertures with different spatial frequencies according to various embodiments of the present invention.

[0068] FIG. 6 is plot illustrating foci separation for apertures with different aperture spatial frequencies according to various embodiments of the present invention.

[0069] FIG. 7 is plot illustrating foci separation for apertures with different aperture spatial frequencies according to various embodiments of the present invention.

[0070] FIG. 8 is a schematic representation of aperture poling with a spatial frequency that can be modified by excitation of channels according to various embodiments of the present invention.

[0071] FIG. 9 is a schematic representation of a poled ceramic with a spatial frequency that can be modified by excitation of channels covering two poled areas of the ceramic according to various embodiments of the present invention.

[0072] FIG. 10 is a schematic representation of an embodiment of array transducer with an imaging transducer.

[0073] FIG. 11 is schematic views of a transducer as viewed from a convex side, side view cross section, and concave side according to various embodiments of the present invention.

[0074] FIG. 12 is schematic views of a transducer as viewed from a convex side, side view cross section, and concave side according to various embodiments of the present invention.

[0075] FIG. 13 is schematic views of a transducer as viewed from a convex side, side view cross section, and concave side according to various embodiments of the present invention.

[0076] FIG. 14 is schematic views of a transducer as viewed from a convex side, side view cross section, and concave side according to various embodiments of the present invention.

[0077] FIG. 15 is schematic views of a transducer as viewed from a convex side, side view cross section, and concave side according to various embodiments of the present invention.

[0078] FIG. 16 is schematic views of a transducer as viewed from a convex side, side view cross section, and concave side according to various embodiments of the present invention.

[0079] FIG. 17 is a schematic view of a transducer as viewed from a convex side and a concave side according to various embodiments of the present invention.

[0080] FIG. 18 is a schematic view of multiple thermal coagulation zones at various depths produced by a transducer according to various embodiments of the present invention.

[0081] FIG. 19 is a schematic view from a x-z plane of the multiple thermal coagulation zones at various depths produced by a transducer according to FIG. 18.

[0082] FIG. 20 is a schematic view from a y-z plane of the multiple thermal coagulation zones at various depths produced by a transducer according to FIG. 18.

[0083] FIG. 21 is a schematic view of multiple thermal coagulation zones at various depths produced by a transducer according to various embodiments of the present invention.

[0084] FIG. 22 is a schematic view from a x-z plane of the multiple thermal coagulation zones at various depths produced by a transducer according to FIG. 21.

[0085] FIG. 23 is a schematic view from a y-z plane of the multiple thermal coagulation zones at various depths produced by a transducer according to FIG. 21.

[0086] FIG. 24 is a schematic view of multiple thermal coagulation zones at various depths produced by a transducer according to various embodiments of the present invention.

[0087] FIG. 25 is a schematic view from a x-z plane of the multiple thermal coagulation zones at various depths produced by a transducer according to FIG. 24.

[0088] FIG. 26 is a schematic view from a y-z plane of the multiple thermal coagulation zones at various depths produced by a transducer according to FIG. 24.

[0089] FIG. 27 is a schematic view of multiple thermal coagulation zones at various depths produced by a transducer according to various embodiments of the present invention.

[0090] FIG. 28 is a schematic view from a x-z plane of the multiple thermal coagulation zones at various depths produced by a transducer according to FIG. 27.

[0091] FIG. 29 is a schematic view from a y-z plane of the multiple thermal coagulation zones at various depths produced by a transducer according to FIG. 27.

[0092] FIG. 30 is a schematic view of a transducer as viewed from a convex side and a concave side according to various embodiments of the present invention.

[0093] FIG. 31 is a schematic view of multiple thermal coagulation zones at various depths produced by a transducer according to various embodiments of the present invention.

[0094] FIG. 32 is a schematic view from a x-z plane of the multiple thermal coagulation zones at various depths produced by a transducer according to FIG. 31.

[0095] FIG. 33 is a schematic view from a y-z plane of the multiple thermal coagulation zones at various depths produced by a transducer according to FIG. 31.

[0096] FIG. 34 is a schematic view of multiple thermal coagulation zones at various depths produced by a transducer according to various embodiments of the present invention.

[0097] FIG. 35 is a schematic view from a x-z plane of the multiple thermal coagulation zones at various depths produced by a transducer according to FIG. 34.

[0098] FIG. 36 is a schematic view from a y-z plane of the multiple thermal coagulation zones at various depths produced by a transducer according to FIG. 34.

[0099] FIG. 37 is plot illustrating amplitude and direct current corresponding to focal plane foci produced by a transducer according to various embodiments of the present invention.

DETAILED DESCRIPTION

[0100] The following description sets forth examples of embodiments, and is not intended to limit the present invention or its teachings, applications, or uses thereof. It should be understood that throughout the drawings, corresponding reference numerals indicate like or corresponding parts and features. The description of specific examples indicated in various embodiments of the present invention are intended for purposes of illustration only and are not intended to limit the scope of the invention disclosed herein. Moreover, recitation of multiple embodiments having stated features is not intended to exclude other embodiments having additional features or other embodiments incorporating different combinations of the stated features. Further, features in one embodiment (such as in one figure) may be combined with descriptions (and figures) of other embodiments.

[0101] In various embodiments, systems and methods for ultrasound treatment of tissue are adapted for and/or configured to provide cosmetic treatment. In some embodiments, devices and methods of directing ultrasound therapy to a single focus point or multiple, simultaneous focus points, employing ultrasound imaging to confirm sufficient acoustic coupling to a treatment area for improving performance or providing improved correlation between movement in a first and second direction when forming images in cosmetic and/or medical procedures are provided in several embodiments. In various embodiments as used herein, “simultaneous” refers to occurring at the same time, or with a time difference of less than 1 ms, 0.5 ms, 0.1 ms, 0.05 ms, or 0.01 ms. In various embodiments, tissue below or even at a skin surface such as epidermis, dermis, fascia, muscle, fat, and superficial muscular aponeurotic system (“SMAS”), are treated non-invasively with ultrasound energy. The ultrasound energy can be focused at one or more

treatment points and/or zones, can be unfocused and/or defocused, and can be applied to a region of interest containing at least one of epidermis, dermis, hypodermis, fascia, muscle, fat, cellulite, and SMAS to achieve a cosmetic and/or therapeutic effect. In various embodiments, systems and/or methods provide non-invasive dermatological treatment to tissue through thermal treatment, coagulation, ablation, and/or tightening. In several embodiments disclosed herein, non-invasive ultrasound is used to achieve one or more of the following effects: a face lift, a brow lift, a chin lift, an eye treatment (e.g., malar bags, treat infraorbital laxity), a wrinkle reduction, fat reduction (e.g., treatment of adipose and/or cellulite), cellulite treatment (e.g., dimple or non-dimple type female gynoid lipodystrophy), décolletage improvement (e.g., upper chest), a buttock lift (e.g., buttock tightening), a skin laxity treatment (e.g., treatment of tissue for tightening or an abdominal laxity treatment), a scar reduction, a burn treatment, a tattoo removal, a vein removal, a vein reduction, a treatment on a sweat gland, a treatment of hyperhidrosis, sun spot removal, an acne treatment, and a pimple removal. In one embodiment, fat reduction is achieved. In various embodiments, cellulite (e.g., dimple or non-dimple type gynoid lipodystrophy) reduction or amelioration of one or more characteristics (such as dimples, nodularity, "orange peel" appearance, etc., is achieved by about 10-20%, 20-40%, 40-60%, 60-80% or higher (as well as overlapping ranging therein) as compared to, for example, untreated tissue. In one embodiment, décolletage is treated. In some embodiments, two, three or more beneficial effects are achieved during the same treatment session, and may be achieved simultaneously.

[0102] Various embodiments of the present invention relate to devices or methods of controlling the delivery of energy to tissue. In various embodiments, various forms of energy can include acoustic, ultrasound, light, laser, radio-frequency (RF), microwave, electromagnetic, radiation, thermal, cryogenic, electron beam, photon-based, magnetic, magnetic resonance, and/or other energy forms. Various embodiments of the present invention relate to devices or methods of splitting an ultrasonic energy beam into multiple beams. In various embodiments, devices or methods can be used to alter the delivery of ultrasound acoustic energy in any procedures such as, but not limited to, therapeutic ultrasound, diagnostic ultrasound, ultrasonic welding, any application that involves coupling mechanical waves to an object, and other procedures. Generally, with therapeutic ultrasound,

a tissue effect is achieved by concentrating the acoustic energy using focusing techniques from the aperture. In some instances, high intensity focused ultrasound (HIFU) is used for therapeutic purposes in this manner. In one embodiment, a tissue effect created by application of therapeutic ultrasound at a particular depth to can be referred to as creation of a thermal coagulation point (TCP). In some embodiments, a zone can include a point. In some embodiments, a zone is a line, plane, spherical, elliptical, cubical, or other one-, two-, or three-dimensional shape. It is through creation of TCPs at particular positions that thermal and/or mechanical ablation of tissue can occur non-invasively or remotely. In some embodiments, an ultrasound treatment does not include cavitation and/or shock waves. In some embodiments, an ultrasound treatment includes cavitation and/or shock waves.

[0103] In one embodiment, TCPs can be created in a linear or substantially linear, curved or substantially curved, zone or sequence, with each individual TCP separated from neighboring TCPs by a treatment spacing. In one embodiment, multiple sequences of TCPs can be created in a treatment region. For example, TCPs can be formed along a first sequence and a second sequence separated by a treatment distance from the first sequence. Although treatment with therapeutic ultrasound can be administered through creation of individual TCPs in a sequence and sequences of individual TCPs, it may be desirable to reduce treatment time and corresponding risk of pain and/or discomfort experienced by a patient. Therapy time can be reduced by forming multiple TCPs simultaneously, nearly simultaneously, or sequentially. In some embodiments, a treatment time can be reduced 10%, 20%, 25%, 30%, 35%, 40%, 45%, 50%, 55%, 60%, 65%, 70%, 75%, 80% or more by creating multiple TCPs.

[0104] Various embodiments of the present invention address potential challenges posed by administration of ultrasound therapy. In various embodiments, time for effecting the formation of TCPs for a desired cosmetic and/or therapeutic treatment for a desired clinical approach at a target tissue is reduced. In various embodiments, target tissue is, but is not limited to, any of skin, eyelids, eye lash, eye brow, caruncula lacrimalis, crow's feet, wrinkles, eye, nose, mouth (e.g., nasolabial fold, perioral wrinkles), tongue, teeth, gums, ears, brain, heart, lungs, ribs, abdomen (e.g., for abdominal laxity), stomach, liver, kidneys, uterus, breast, vagina, prostate, testicles, glands, thyroid glands, internal organs, hair, muscle, bone,

ligaments, cartilage, fat, fat labuli, adipose tissue, subcutaneous tissue, implanted tissue, an implanted organ, lymphoid, a tumor, a cyst, an abscess, or a portion of a nerve, or any combination thereof.

[0105] Various embodiments of simultaneous ultrasound treatment at multiple locations in tissue are described in U.S. Application No. 14/193,234, which published as U.S. Publication No. 2014/0257145 on September 11, 2014, which is incorporated in its entirety by reference, herein.

System Overview

[0106] With reference to the illustration in FIGS. 1A, 1B, and 1C, various embodiments of an ultrasound system 20 includes a hand wand (e.g., handpiece) 100, module (e.g., transducer module, cartridge, probe) 200, and a controller (e.g., console) 300. In some embodiments, a console 300 comprises a communication system (e.g., wifi, Bluetooth, modem, etc. to communicate with another party, a manufacturer, a supplier, a service provider, the Internet, and/or a cloud. In some embodiments, a cart 301 provides mobility and/or position of the system 20, and can include wheels, surfaces to write on or place components, and/or compartments 302 (e.g., drawers, containers, shelves, etc.) to, for example, store or organize components. In some embodiments, the cart has a power supply, such as a power connection to a battery and/or one or more cords to connect power, communications (e.g., Ethernet) to the system 20. In some embodiments, the system 20 comprises a cart 301. In some embodiments, the system 20 does not comprise a cart 301. The hand wand 100 can be coupled to the controller 300 by an interface 130, which may be a wired or wireless interface. The interface 130 can be coupled to the hand wand 100 by a connector 145. The distal end of the interface 130 can be connected to a controller connector on a circuit 345 (not shown). In one embodiment, the interface 130 can transmit controllable power from the controller 300 to the hand wand 100. In an embodiment, the system 20 has multiple imaging channels (e.g., 8 channels) for ultra-clear HD (high definition) visualization of subcutaneous structures to improve imaging. In an embodiment, the system 20 multiple therapy channels (e.g., 8 channels) and a precision linear-drive motor that doubles treatment accuracy while increasing speed (e.g., by 25%, 40%, 50%, 60%, 75%, 100% or more).

Together, these features establish one of the most versatile system platforms in the industry and provide a foundation for unprecedented future possibilities.

[0107] In various embodiments, the controller 300 can be adapted to and/or configured for operation with the hand wand 100 and the module 200, as well as the overall ultrasound system 20 functionality. In various embodiments, multiple controllers 300, 300', 300", etc. can be adapted to and/or configured for operation with multiple hand wands 100, 100', 100", etc. and or multiple modules 200, 200', 200", etc. The controller 300 can include connectivity to one or more interactive graphical display 310, which can include a touchscreen monitor and Graphic User Interface (GUI) that allows the user to interact with the ultrasound system 20. In one embodiment, a second smaller, more mobile display that allows the user to more easily position and view the treatment screen. In one embodiment, a second display that allows the system user to view a treatment screen (e.g., on a wall, on a mobile device, large screen, remote screen). In one embodiment the graphical display 310 includes a touchscreen interface 315 (not shown). In various embodiments, the display 310 sets and displays the operating conditions, including equipment activation status, treatment parameters, system messages and prompts, and ultrasound images. In various embodiments, the controller 300 can be adapted to and/or configured to include, for example, a microprocessor with software and input/output devices, systems and devices for controlling electronic and/or mechanical scanning and/or multiplexing of transducers and/or multiplexing of transducer modules, a system for power delivery, systems for monitoring, systems for sensing the spatial position of the probe and/or transducers and/or multiplexing of transducer modules, and/or systems for handling user input and recording treatment results, among others. In various embodiments, the controller 300 can include a system processor and various analog and/or digital control logic, such as one or more of microcontrollers, microprocessors, field-programmable gate arrays, computer boards, and associated components, including firmware and control software, which may be capable of interfacing with user controls and interfacing circuits as well as input/output circuits and systems for communications, displays, interfacing, storage, documentation, and other useful functions. System software running on the system process may be adapted to and/or configured to control all initialization, timing, level setting, monitoring, safety monitoring,

and all other ultrasound system functions for accomplishing user-defined treatment objectives. Further, the controller 300 can include various input/output modules, such as switches, buttons, etc., that may also be suitably adapted to and/or configured to control operation of the ultrasound system 20.

[0108] In one embodiment, the hand wand 100 includes one or more finger activated controllers or switches, such as 150 and 160. In various embodiments, one or more thermal treatment controllers 160 (e.g., switch, button) activates and/or stops treatment. In various embodiments, one or more imaging controllers 150 (e.g., switch, button) activates and/or stops imaging. In one embodiment, the hand wand 100 can include a removable module 200. In other embodiments, the module 200 may be non-removable. In various embodiments, the module 200 can be mechanically coupled to the hand wand 100 using a latch or coupler 140. In various embodiments, an interface guide 235 or multiple interface guides 235 can be used for assisting the coupling of the module 200 to the hand wand 100. The module 200 can include one or more ultrasound transducers 280. In some embodiments, an ultrasound transducer 280 includes one or more ultrasound elements. The module 200 can include one or more ultrasound elements. The hand wand 100 can include imaging-only modules, treatment-only modules, imaging-and-treatment modules, and the like. In various embodiments, the ultrasound transducer 280 is movable in one or more directions 290 within the module 200. The transducer 280 is connected to a motion mechanism 400. In various embodiments, the motion mechanism comprises zero, one, or more bearings, shafts, rods, screws, lead screws 401, encoders 402 (e.g., optical encoder to measure position of the transducer 280), motors 403 (e.g., a step motor) to help ensure accurate and repeatable movement of the transducer 280 within the module 200. In various embodiments, module 200 can include a transducer 280 which can emit energy through an acoustically transparent member 230. In one embodiment, the control module 300 can be coupled to the hand wand 100 via the interface 130, and the graphic user interface 310 can be adapted to and/or configured for controlling the module 200. In one embodiment, the control module 300 can provide power to the hand wand 100. In one embodiment, the hand wand 100 can include a power source. In one embodiment, the switch 150 can be adapted to and/or configured for controlling a tissue imaging function and the switch 160 can be adapted to and/or configured

for controlling a tissue treatment function. In various embodiments, delivery of emitted energy 50 at a suitable focal depth, distribution, timing, and energy level is provided by the module 200 through controlled operation by the control system 300 of the transducer 280 to achieve the desired therapeutic effect with a thermal coagulation zone 550 (“TCP” e.g., a thermal coagulation point).

[0109] In one embodiment, the module 200 can be coupled to the hand wand 100. The module 200 can emit and receive energy, such as ultrasonic energy. The module 200 can be electronically coupled to the hand wand 100 and such coupling may include an interface which is in communication with the controller 300. In one embodiment, the interface guide 235 can be adapted to and/or configured to provide electronic communication between the module 200 and the hand wand 100. The module 200 can comprise various probe and/or transducer configurations. For example, the module 200 can be adapted to and/or configured for a combined dual-mode imaging/therapy transducer, coupled or co-housed imaging/therapy transducers, separate therapy and imaging probes, and the like. In one embodiment, when the module 200 is inserted into or connected to the hand wand 100, the controller 300 automatically detects it and updates the interactive graphical display 310.

[0110] In some embodiments, an access key 320 (e.g., a secure USB drive, key) is connected (e.g., removably) to a system 20 to permit the system 20 to function. In various embodiments, the access key is programmed to be customer specific, and serves multiple functions, including system security, country/region specific access to treatment guidelines and functionality, software upgrades, support log transfers and /or credit transfer and/or storage. In various embodiments, the system 20 has internet and/or data connectivity. In an embodiment, connectivity provides a method by which data is transferred between the system 20 provider and the customer. In various embodiments, data includes credits, software updates and support logs. Connectivity is divided into different model embodiments, based on how a user’s console is connected to the internet. In one embodiment, Disconnected Model connectivity comprises a console that is disconnected from the internet and customer doesn’t have internet access. Credit transfers and software upgrades are conducted by shipping access key(s), (e.g., USB drives) to the customer. In one embodiment, Semi-Connected Model connectivity comprises a console that is disconnected from the internet but

customer has internet access. Credit transfers, software upgrades and support log transfers are conducted using the customer's personal computer, smart phone, or other computing device in conjunction with the system access key to transfer data. In one embodiment, Fully-Connected Model connectivity comprises a console that is wirelessly connected to the internet using wifi, cellular modem, Bluetooth, or other protocol. Credit transfers, software upgrades and support log transfers are made directly between the console and the cloud. In various embodiments, the system 20 connects to an online portal, for streamlined inventory management, on-demand treatment purchases and business analytics insights to drive customer aesthetic treatment business to the next level.

[0111] In various embodiments, tissue below or even at a skin surface such as epidermis, dermis, hypodermis, fascia, and superficial muscular aponeurotic system ("SMAS"), and/or muscle are treated non-invasively with ultrasound energy. Tissue may also include blood vessels and/or nerves. The ultrasound energy can be focused, unfocused or defocused and applied to a region of interest containing at least one of epidermis, dermis, hypodermis, fascia, and SMAS to achieve a therapeutic effect. FIG. 2 is a schematic illustration of the ultrasound system 20 coupled to a region of interest 10. In various embodiments, tissue layers of the region of interest 10 can be at any part of the body of a subject. In one embodiment, the tissue layers are in the head and face region of the subject. The cross-sectional portion of the tissue of the region of interest 10 includes a skin surface 501, an epidermal layer 502, a dermal layer 503, a fat layer 505, a superficial muscular aponeurotic system 507 (hereinafter "SMAS 507"), and a muscle layer 509. The tissue can also include the hypodermis 504, which can include any tissue below the dermal layer 503. The combination of these layers in total may be known as subcutaneous tissue 510. Also illustrated in FIG. 2 is a treatment zone 525 which is below the surface 501. In one embodiment, the surface 501 can be a surface of the skin of a subject 500. Although an embodiment directed to therapy at a tissue layer may be used herein as an example, the system can be applied to any tissue in the body. In various embodiments, the system and/or methods may be used on tissue (including but not limited to one or a combination of muscles, fascia, SMAS, dermis, epidermis, fat, adipose cells, cellulite, which may be called gynoid lipodystrophy, (e.g., non-dimple type female gynoid lipodystrophy), collagen, skin, blood

vessels, of the face, neck, head, arms, legs, or any other location on or in the body (including bodily cavities). In various embodiments, cellulite (e.g., non-dimple type female gynoid lipodystrophy) reduction is achieved in an amount of 2%, 5%, 10%, 15%, 20%, 25%, 30%, 40%, 50%, 75%, 80%, 90%, 95%, and any ranges therein.

[0112] With reference to the illustration in FIG. 2, an embodiment of the ultrasound system 20 includes the hand wand 100, the module 200, and the controller 300. In one embodiment, the module 200 includes a transducer 280. FIG. 3 illustrates an embodiment of an ultrasound system 20 with a transducer 280 adapted to and/or configured to treat tissue at multiple focal depths 278. In one embodiment, the focal depth 278 is a distance between the transducer 280 and the target tissue for treatment. In one embodiment, a focal depth 278 is fixed for a given transducer 280. In one embodiment, a focal depth 278 is variable for a given transducer 280. In one embodiment, a transducer 280 is configured to treat simultaneously at multiple depths below a skin surface (e.g., 1.5 mm, 3.0 mm, 4.5 mm, or other depths).

[0113] With reference to the illustration in FIG. 4, the module 200 can include a transducer 280 which can emit energy through an acoustically transparent member 230. In various embodiments, a depth may refer to the focal depth 278. In one embodiment, the transducer 280 can have an offset distance 270, which is the distance between the transducer 280 and a surface of the acoustically transparent member 230. In one embodiment, the focal depth 278 of a transducer 280 is a fixed distance from the transducer. In one embodiment, a transducer 280 may have a fixed offset distance 270 from the transducer to the acoustically transparent member 230. In one embodiment, an acoustically transparent member 230 is adapted to and/or configured at a position on the module 200 or the ultrasound system 20 for contacting the skin surface 501. In various embodiments, the focal depth 278 exceeds the offset distance 270 by an amount to correspond to treatment at a target area located at a tissue depth 279 below a skin surface 501. In various embodiments, when the ultrasound system 20 placed in physical contact with the skin surface 501, the tissue depth 279 is a distance between the acoustically transparent member 230 and the target area, measured as the distance from the portion of the hand wand 100 or module 200 surface that contacts skin (with or without an acoustic coupling gel, medium, etc.) and the depth in tissue from that skin

surface contact point to the target area. In one embodiment, the focal depth 278 can correspond to the sum of an offset distance 270 (as measured to the surface of the acoustically transparent member 230 in contact with a coupling medium and/or skin 501) in addition to a tissue depth 279 under the skin surface 501 to the target region. In various embodiments, the acoustically transparent member 230 is not used.

[0114] Coupling components can comprise various substances, materials, and/or devices to facilitate coupling of the transducer 280 or module 200 to a region of interest. For example, coupling components can comprise an acoustic coupling system adapted to and/or configured for acoustic coupling of ultrasound energy and signals. Acoustic coupling system with possible connections such as manifolds may be utilized to couple sound into the region of interest, provide liquid- or fluid-filled lens focusing. The coupling system may facilitate such coupling through use of one or more coupling media, including air, gases, water, liquids, fluids, gels, solids, non-gels, and/or any combination thereof, or any other medium that allows for signals to be transmitted between the transducer 280 and a region of interest. In one embodiment one or more coupling media is provided inside a transducer. In one embodiment a fluid-filled module 200 contains one or more coupling media inside a housing. In one embodiment a fluid-filled module 200 contains one or more coupling media inside a sealed housing, which is separable from a dry portion of an ultrasonic device. In various embodiments, a coupling medium is used to transmit ultrasound energy between one or more devices and tissue with a transmission efficiency of 100%, 99% or more, 98% or more, 95% or more, 90% or more, 80% or more, 75% or more, 60% or more, 50% or more, 40% or more, 30% or more, 25% or more, 20% or more, 10% or more, and/or 5% or more.

[0115] In various embodiments, the transducer 280 can image and treat a region of interest at any suitable tissue depths 279. In one embodiment, the transducer module 280 can provide an acoustic power in a range of about 1 W or less, between about 1 W to about 100 W, and more than about 100 W, e.g., 200 W, 300 W, 400 W, 500 W. In one embodiment, the transducer module 280 can provide an acoustic power at a frequency of about 1 MHz or less, between about 1 MHz to about 10 MHz (e.g., 3 MHz, 4 MHz, 4.5 MHz, 7 MHz, 10 MHz), and more than about 10 MHz. In one embodiment, the module 200 has a focal depth 278 for a treatment at a tissue depth 279 of about 4.5 mm below the skin surface

501. In one embodiment, the module 200 has a focal depth 278 for a treatment at a tissue depth 279 of about 3 mm below the skin surface 501. In one embodiment, the module 200 has a focal depth 278 for a treatment at a tissue depth 279 of about 1.5 mm below the skin surface 501. Some non-limiting embodiments of transducers 280 or modules 200 can be adapted to and/or configured for delivering ultrasonic energy at a tissue depth of 1.5 mm, 3 mm, 4.5 mm, 6 mm, 7 mm, less than 3 mm, between 3 mm and 4.5 mm, between 4.5 mm and 6 mm, more than more than 4.5 mm, more than 6 mm, etc., and anywhere in the ranges of 0-3 mm, 0-4.5 mm, 0-6 mm, 0-25 mm, 0-100 mm, etc. and any depths therein. In one embodiment, the ultrasound system 20 is provided with two or more transducer modules 280. For example, a first transducer module can apply treatment at a first tissue depth (e.g., about 4.5 mm) and a second transducer module can apply treatment at a second tissue depth (e.g., of about 3 mm), and a third transducer module can apply treatment at a third tissue depth (e.g., of about 1.5-2 mm). In one embodiment, at least some or all transducer modules can be adapted to and/or configured to apply treatment at substantially same depths.

[0116] In various embodiments, changing the number of focus point locations (e.g., such as with a tissue depth 279) for an ultrasonic procedure can be advantageous because it permits treatment of a patient at varied tissue depths even if the focal depth 278 of a transducer 270 is fixed. This can provide synergistic results and maximizing the clinical results of a single treatment session. For example, treatment at multiple depths under a single surface region permits a larger overall volume of tissue treatment, which results in enhanced collagen formation and tightening. Additionally, treatment at different depths affects different types of tissue, thereby producing different clinical effects that together provide an enhanced overall cosmetic result. For example, superficial treatment may reduce the visibility of wrinkles and deeper treatment may induce formation of more collagen growth. Likewise, treatment at various locations at the same or different depths can improve a treatment.

[0117] Although treatment of a subject at different locations in one session may be advantageous in some embodiments, sequential treatment over time may be beneficial in other embodiments. For example, a subject may be treated under the same surface region at one depth in time one, a second depth in time two, etc. In various embodiments, the time can be on the order of nanoseconds, microseconds, milliseconds, seconds, minutes, hours, days,

weeks, months, or other time periods. The new collagen produced by the first treatment may be more sensitive to subsequent treatments, which may be desired for some indications. Alternatively, multiple depth treatment under the same surface region in a single session may be advantageous because treatment at one depth may synergistically enhance or supplement treatment at another depth (due to, for example, enhanced blood flow, stimulation of growth factors, hormonal stimulation, etc.). In several embodiments, different transducer modules provide treatment at different depths. In one embodiment, a single transducer module can be adjusted or controlled for varied depths. Safety features to minimize the risk that an incorrect depth will be selected can be used in conjunction with the single module system.

[0118] In several embodiments, a method of treating the lower face and neck area (e.g., the submental area) is provided. In several embodiments, a method of treating (e.g., softening) mentolabial folds is provided. In other embodiments, a method of treating the eye region (e.g., malar bags, treat infraorbital laxity) is provided. Upper lid laxity improvement and periorbital lines and texture improvement will be achieved by several embodiments by treating at variable depths. By treating at varied locations in a single treatment session, optimal clinical effects (e.g., softening, tightening) can be achieved. In several embodiments, the treatment methods described herein are non-invasive cosmetic procedures. In some embodiments, the methods can be used in conjunction with invasive procedures, such as surgical facelifts or liposuction, where skin tightening is desired. In various embodiments, the methods can be applied to any part of the body.

[0119] In one embodiment, a transducer module 200 permits a treatment sequence at a fixed depth at or below the skin surface. In one embodiment, a transducer module permits a treatment sequence at one, two, or more variable or fixed depths below the dermal layer. In several embodiments, the transducer module comprises a movement mechanism adapted to and/or configured to direct ultrasonic treatment in a sequence of individual thermal lesions (hereinafter “thermal coagulation points” or “TCPs”) at a fixed focal depth. In one embodiment, the sequence of individual TCPs has a treatment spacing in a range from about 0.01 mm to about 25 mm (e.g., 1 mm, 1.5 mm, 2 mm, 2.5 mm, 3 mm, 5 mm, 10 mm, 20 mm and any value ranges therein), with a dithering alteration of the spacing by 1 – 50% (e.g., 1%, 5%, 10%, 15%, 20%, 25%, 30%, 35%, 40%, 45%, 50% and any range therein). For

example, the spacing can be 1.1 mm or less, 1.5 mm or more, between about 1.1 mm and about 1.5 mm, etc. In one embodiment, the individual TCPs are discrete. In one embodiment, the individual TCPs are overlapping. In one embodiment, the movement mechanism is adapted to and/or configured to be programmed to provide variable spacing between the individual TCPs. In one embodiment, the dithering can be adapted to and/or configured to provide variable spacing between the individual TCPs. In several embodiments, a transducer module comprises a movement mechanism adapted to and/or configured to direct ultrasonic treatment in a sequence so that TCPs are formed in linear or substantially linear sequences separated by a treatment distance. For example, a transducer module can be adapted to and/or configured to form TCPs along a first linear sequence and a second linear sequence separated by a treatment distance from the first linear sequence. In one embodiment, treatment distance between adjacent linear sequences of individual TCPs is in a range from about 0.01 mm to about 25 mm. In one embodiment, treatment distance between adjacent linear sequences of individual TCPs is in a range from about 0.01 mm to about 50 mm. For example, the treatment distance can be 2 mm or less, 3 mm or more, between about 2 mm and about 3 mm, etc. In several embodiments, a transducer module can comprise one or more movement mechanisms 400 adapted to and/or configured to direct ultrasonic treatment in a sequence so that TCPs are formed in linear or substantially linear sequences of individual thermal lesions separated by a treatment distance from other linear sequences. In one embodiment a treatment is applied in a first direction 290 (e.g., push). In one embodiment, a treatment is applied opposite the first direction 290 (e.g., pull). In one embodiment, treatment is applied in both a first direction 290 and opposite the first direction (e.g., push and pull). In one embodiment, the treatment distance separating linear or substantially linear TCPs sequences is the same or substantially the same. In one embodiment, the treatment distance separating linear or substantially linear TCPs sequences is different or substantially different for various adjacent pairs of linear TCPs sequences.

[0120] In one embodiment, first and second removable transducer modules are provided. In one embodiment, each of the first and second transducer modules are adapted to and/or configured for both ultrasonic imaging and ultrasonic treatment. In one embodiment, a transducer module is adapted to and/or configured for treatment only. In one embodiment, an

imaging transducer may be attached to a handle of a probe or a hand wand. The first and second transducer modules are adapted to and/or configured for interchangeable coupling to a hand wand. The first transducer module is adapted to and/or configured to apply ultrasonic therapy to a first layer of tissue, while the second transducer module is adapted to and/or configured to apply ultrasonic therapy to a second layer of tissue. The second layer of tissue is at a different depth than the first layer of tissue.

[0121] As illustrated in FIG. 3, in various embodiments, delivery of emitted energy 50 at a suitable focal depth 278, distribution, timing, and energy level is provided by the module 200 through controlled operation by the control system 300 to achieve the desired therapeutic effect of controlled thermal injury to treat at least one of the epidermis layer 502, dermis layer 503, fat layer 505, the SMAS layer 507, the muscle layer 509, and/or the hypodermis 504. FIG. 3 illustrates one embodiment of a depth that corresponds to a depth for treating muscle. In various embodiments, the depth can correspond to any tissue, tissue layer, skin, epidermis, dermis, hypodermis, fat, SMAS, muscle, blood vessel, nerve, or other tissue. During operation, the module 200 and/or the transducer 280 can also be mechanically and/or electronically scanned along the surface 501 to treat an extended area. Before, during, and after the delivery of ultrasound energy 50 to at least one of the epidermis layer 502, dermis layer 503, hypodermis 504, fat layer 505, the SMAS layer 507 and/or the muscle layer 509, monitoring of the treatment area and surrounding structures can be provided to plan and assess the results and/or provide feedback to the controller 300 and the user via a graphical interface 310.

[0122] In one embodiment, an ultrasound system 20 generates ultrasound energy which is directed to and focused below the surface 501. This controlled and focused ultrasound energy 50 creates the thermal coagulation point or zone (TCP) 550. In one embodiment, the ultrasound energy 50 creates a void in subcutaneous tissue 510. In various embodiments, the emitted energy 50 targets the tissue below the surface 501 which cuts, ablates, coagulates, micro-ablates, manipulates, and/or causes a TCP 550 in the tissue portion 10 below the surface 501 at a specified focal depth 278. In one embodiment, during the treatment sequence, the transducer 280 moves in a direction denoted by the arrow marked 290 at specified intervals 295 to create a series of treatment zones 254 each of which receives

an emitted energy 50 to create one or more TCPs 550. In one embodiment, an arrow marked 291 illustrates an axis or direction that is orthogonal or parallel to arrow 290, and a spacing of TCP's 550 show TCP's can be spaced orthogonally or parallel to the motion direction of the transducer 280. In some embodiments, an orientation of the spaced TCP's can be set at any angle 0 – 180 degrees from arrow 290. In some embodiments, an orientation of the spaced TCP's can be set at any angle 0 – 180 degrees based on the orientation of poled areas on the transducer 280.

[0123] In various embodiments, transducer modules can comprise one or more transduction elements. The transduction elements can comprise a piezoelectrically active material, such as lead zirconate titanate (PZT), or any other piezoelectrically active material, such as a piezoelectric ceramic, crystal, plastic, and/or composite materials, as well as lithium niobate, lead titanate, barium titanate, and/or lead metaniobate. In various embodiments, in addition to, or instead of, a piezoelectrically active material, transducer modules can comprise any other materials adapted to and/or configured for generating radiation and/or acoustical energy. In various embodiments, transducer modules can be adapted to and/or configured to operate at different frequencies and treatment depths. Transducer properties can be defined by an outer diameter (“OD”) and focal length (F_L). In one embodiment, a transducer can be adapted to and/or configured to have $OD = 19$ mm and $F_L = 15$ mm. In other embodiments, other suitable values of OD and F_L can be used, such as OD of less than about 19 mm, greater than about 19 mm, etc. and F_L of less than about 15 mm, greater than about 15 mm, etc. Transducer modules can be adapted to and/or configured to apply ultrasonic energy at different target tissue depths. As described above, in several embodiments, transducer modules comprise movement mechanisms adapted to and/or configured to direct ultrasonic treatment in a linear or substantial linear sequence of individual TCPs with a treatment spacing between individual TCPs. For example, treatment spacing can be about 1.1 mm, 1.5 mm, etc. In several embodiments, transducer modules can further comprise movement mechanisms adapted to and/or configured to direct ultrasonic treatment in a sequence so that TCPs are formed in linear or substantially linear sequences separated by a treatment spacing. For example, a transducer module can be adapted to and/or configured to form TCPs along a first linear sequence and a second linear sequence separated by treatment

spacing between about 2 mm and 3 mm from the first linear sequence. In one embodiment, a user can manually move the transducer modules across the surface of a treatment area so that adjacent linear sequences of TCPs are created. In one embodiment, a movement mechanism can automatically move the transducer modules across the surface of a treatment area so that adjacent linear sequences of TCPs are created.

Aperture Spatial Frequency Analysis and Fourier Transform

[0124] In various embodiments, spatial frequency analysis techniques based on Fourier analysis and Fourier optics can be used to increase efficiency of therapeutic treatment. When a system that has an impulse response $h(t)$ is excited by a stimulus $x(t)$, the relationship between the input $x(t)$ and output $y(t)$ is related by the convolution function as follows:

$$y(t) = x(t) * h(t) = \int_{-\infty}^{\infty} x(\tau)h(t - \tau)d\tau \quad (1)$$

[0125] In various embodiments, Fourier transform can be applied to compute the convolution of equation (1). Continuous one-dimensional Fourier transform can be defined as:

$$Y(f) = F(y(t)) = \int_{-\infty}^{\infty} y(t) e^{-j2\pi ft} dt \quad (2)$$

[0126] here f is frequency, t is time. It can be shown that convolution in the time domain is equivalent to multiplication in the frequency domain:

$$F(x(t) * h(t)) = X(f)H(f) = Y(f) \quad (3)$$

[0127] In various embodiments, the Fraunhofer approximation can be used for deriving a relationship between a transducer opening or aperture and a resulting ultrasonic beam response. Derivation of the Fraunhofer approximation is described in Joseph Goodman, *Introduction to Fourier Optics* (3d ed. 2004), which is incorporated in its entirety by reference, herein. According to the Fraunhofer approximation, a far-field complex amplitude pattern produced by a complex aperture is equal to a two-dimensional Fourier transform of the aperture amplitude and phase. In several embodiments, this relationship in optics can be extended to ultrasound since linear wave equations can be used to represent both light propagation and sound propagation. In the case of optics and/or ultrasound, the two-

dimensional Fourier transform can determine a sound wave pressure amplitude distribution at the focus of a transducer.

[0128] For a focused system, the variable z which represents depth can be replaced with z_f which represents a focal distance.

$$f_x = x_0/\lambda z_f \quad (4a)$$

$$f_y = y_0/\lambda z_f \quad (4b)$$

[0129] In various embodiments, Fourier optics and Fourier transform identities (some of which are listed in Table 1, below) can be used for ultrasound transducers in order to determine the intensity distribution corresponding to a transducer design. For example, Fourier transform of a rectangle $rect(ax)$ is a sinc function. As another example, Fourier transform of a two dimensional circle of uniform amplitude is a first order Bessel function which can be represented as J_1 .

	Aperture Function	Fourier Transform
1	$rect(ax)$	$\frac{1}{ a } sinc\left(\frac{\xi}{a}\right)$
2	$\delta(x)$	1
3	$cos(ax)$	$\frac{\delta\left(\xi - \frac{a}{2\pi}\right) + \delta\left(\xi + \frac{a}{2\pi}\right)}{2}$
4	$sin(ax)$	$\frac{\delta\left(\xi - \frac{a}{2\pi}\right) - \delta\left(\xi + \frac{a}{2\pi}\right)}{2j}$
5 (two-dimensional transform pair)	$circ(\sqrt{x^2 + y^2})$	$\frac{J_1(2\pi\sqrt{\xi_x^2 + \xi_y^2})}{\sqrt{\xi_x^2 + \xi_y^2}}$
6	$f(x) * g(x)$	$F(\xi)G(\xi)$
7	$f(x)g(x)$	$F(\xi) * G(\xi)$

Table 1

[0130] In several embodiments, an ultrasound transducer can have a rectangular aperture of suitable dimensions and focal length. In several embodiments, an ultrasound transducer can have a circular aperture with suitable dimensions and focal length. In one embodiment, a transducer can have a circular aperture with an outer radius of approximately 9.5 mm, an inner diameter of approximately 2 mm, and focal length of approximately 15 mm. The aperture of a circular transducer may be described as:

$$f(x, y) = \text{circ}\left(\frac{r}{a}\right) - \text{circ}\left(\frac{r}{b}\right) \quad (5a)$$

$$r = \sqrt{x^2 + y^2} \quad (5b)$$

[0131] For example, in one embodiment, the variable ‘a’ can be approximately 9.5 mm and the variable ‘b’ in equation (5a) can be approximately 2 mm. Applying Fourier transform to equation (5a) can provide an estimate of the sound wave pressure distribution at the focus.

$$F_{x,y}(f(x, y)) = F(\xi_x, \xi_y) = \frac{a J_1(2\pi a \sqrt{\xi_x^2 + \xi_y^2})}{\sqrt{\xi_x^2 + \xi_y^2}} - \frac{b J_1(2\pi b \sqrt{\xi_x^2 + \xi_y^2})}{\sqrt{\xi_x^2 + \xi_y^2}} \quad (6)$$

[0132] where ξ_x and ξ_y are same as f_x and f_y of equations (4a) and (4b). Equation (6) demonstrates that the sound wave pressure distribution of a transducer with a circular aperture is a first order Bessel function. In one embodiment, a substantial majority of the energy is concentrated at the focus (e.g., 15 mm away from the aperture). The width of a main ultrasonic beam and the distribution of energy away from the main beam can be expressed as a function of the operating frequency as is expressed in equations (4a) and (4b).

[0133] In various embodiments, two identical or nearly identical beams could be created at the focus if the aperture was modulated (e.g., multiplied) by a correct function. In one embodiment, a cosine function can be applied to a circular aperture as follows:

$$g(x, y) = \cos(cx) \left(\text{circ}\left(\frac{r}{a}\right) - \text{circ}\left(\frac{r}{b}\right) \right) \quad (7)$$

[0134] An energy distribution or beam response at the focus of the modulated aperture of equation (7) is the convolution of the Fourier transform of the two functions of the aperture:

$$G(\xi_x, \xi_y) = \left(\frac{\delta(\xi_x - \frac{c}{2\pi}) + \delta(\xi_x + \frac{c}{2\pi})}{2} \right) * F(\xi_x, \xi_y) \quad (8)$$

[0135] Equation (8) can be simplified into the summation of two separate functions applying the Fourier Transform identity for a Dirac delta function (e.g., identity 2 in Table 2):

$$G(\xi_x, \xi_y) = \frac{1}{2} \left(F \left(\xi_x - \frac{c}{2\pi}, \xi_y \right) + F \left(\xi_x + \frac{c}{2\pi}, \xi_y \right) \right) \quad (9)$$

[0136] Equation (9) shows that two beams appearing at the focus are spatially shifted by $\pm \frac{c}{2\pi}$ compared to the original, non-modulated beam. In several embodiments, one or more other modulation functions, such as sine function, can be used to achieve a desired beam response. In several embodiments, aperture can be modulated such that more than two foci are created. For example, three, four, five, etc. foci can be created. In several embodiments, aperture can be modulated such that foci are created sequentially or substantially sequentially rather than simultaneously.

[0137] In several embodiments, therapy transducer modules comprise movement mechanisms configured to direct ultrasonic treatment in a linear or substantially linear sequence of individual TCPs with a treatment spacing between individual TCPs. For example, treatment spacing can be about 1.1 mm, 1.5 mm, etc. In several embodiments, transducer modules can further comprise movement mechanisms configured to direct ultrasonic treatment in a sequence so that TCPs are formed in linear or substantially linear sequences separated by a treatment spacing. For example, a transducer module can be configured to form TCPs along a first linear sequence and a second linear sequence separated by treatment spacing between about 2 mm and 3 mm from the first linear sequence. According to equation (9), a simultaneous or substantially simultaneous split in the ultrasonic beam may be achieved at the focus (or before the focus) if the aperture is modulated by a cosine and/or sine function of a desired spatial frequency. In one embodiment, two simultaneous or nearly simultaneous focused beams separated by about 1.1 mm treatment spacing can be created in a linear or substantially linear sequence. At 7 MHz frequency of ultrasound, the wavelength λ of ultrasound wave in water is approximately 0.220 mm. Accordingly, spatial frequencies ξ_x and ξ_y at the focus are represented as:

$$\xi_x = \frac{f_0}{15 * 0.220} = \frac{f_0}{3.3} \quad (10a)$$

$$\xi_y = \frac{f_0}{15 * 0.220} = \frac{f_0}{3.3} \quad (10b)$$

[0138] In order to place two foci separated by about 1.1 mm, then the spatial frequency for modulating the aperture is calculated as follows. Using identities 3 and 4 in

Table 2, the Fourier transformation of a sine or cosine function is a Dirac delta function with the argument:

$$arg = \frac{x_0}{3.3} - \frac{k_x}{2\pi} \quad (11a)$$

[0139] In one embodiment, equation (11a) can be solved for k_x when argument is 0:

$$k_x = \frac{2\pi x_0}{3.3} \quad (11b)$$

[0140] Further, x_0 can be replaced by half of the separation distance (e.g., 1.1 mm):

$$k_x = \frac{2\pi \frac{5}{2}}{3.3} = \frac{2\pi \frac{1.1}{2}}{3.3} = 1.04 \text{ mm}^{-1} \quad (11c)$$

[0141] In several embodiments, a transducer with circular aperture emitting ultrasonic energy at various operating frequencies can be modulated by a sine and/or cosine functions at spatial frequencies listed in Table 2. Modulated aperture of the transducer can produce a simultaneously or substantially simultaneously split beam with two foci having different separation distances, as is indicated in Table 2. In one embodiment, the transducer can have OD of about 19 mm and a focal length of about 15 mm.

Ultrasound Frequency	Separation Distance Between Foci			
	1.1 mm	1.5 mm	2 mm	3 mm
4 MHz	0.60	0.82	1.09	1.63
7 MHz	1.04	1.43	1.90	2.86
10 MHz	1.50	2.04	2.72	3.08

Table 2

[0142] As is shown in Table 2, in several embodiments, a spatial frequency of an aperture modulation function increases as the ultrasonic operating frequency increases for a given foci separation distance. In addition, the spatial frequency increases as the desired foci separation distance increases.

[0143] In one embodiment, higher spatial frequency can result in amplitude transitions in the aperture occurring more rapidly. Due to transducer processing limitations, rapid amplitude variations in the aperture can make the aperture less efficient as there may be a variance in an amount of sound pressure produced by different parts of the aperture. In one embodiment, using spatial frequencies to simultaneously or nearly simultaneously split the beam can reduce the overall focal gain of each beam. As is shown in equation (9), a field pressure at the focus of each beam is reduced by a factor of two in comparison with an unmodulated beam. In one embodiment, the sound pressure or ultrasound intensity from the aperture can be increased to obtain similar or substantially similar intensities at the focal plane. However, in one embodiment, increasing the pressure at the aperture may not be limited by system and/or transducer processing limitations. In one embodiment, an increase in the pressure at the aperture can increase the overall intensity in the near field, which may increase the possibility of excessively heating treatment area tissue(s) that is located before focus. In one embodiment, the possibility of additional heating of the pre-focal tissue(s) may be limited or eliminated by using a lower ultrasound treatment frequency.

[0144] In one embodiment, applying aperture modulation function as is shown in equation (7) results in two simultaneous or substantially simultaneous ultrasound beams at the focus. In various embodiments, ultrasound beam can be split multiple times, such as three, four, five, etc. times, such that multiple simultaneous or nearly simultaneous beams are created. In one embodiment, four equally spaced beams along one dimension can be generated by modulating or multiplying the aperture by two separate spatial frequencies:

$$g(x, y) = (\cos(cx) + \cos(dx)) \left(\text{circ} \left(\frac{r}{a} \right) - \text{circ} \left(\frac{r}{b} \right) \right) \quad (12a)$$

$$G(\xi_x, \xi_y) = \frac{1}{2} \left(F \left(\xi_x - \frac{c}{2\pi}, \xi_y \right) + F \left(\xi_x + \frac{c}{2\pi}, \xi_y \right) + F \left(\xi_x - \frac{d}{2\pi}, \xi_y \right) + F \left(\xi_x + \frac{d}{2\pi}, \xi_y \right) \right) \quad (12b)$$

[0145] As is shown in equation (12b), unmodulated beam at the focus can be created at four different locations along the x-axis. In one embodiment, a constant or DC term, C1, may be added to the amplitude modulation function to maintain placement of energy at the original focal location:

$$g(x, y) = (\cos(cx) + \cos(dx) + C_1) \left(\text{circ}\left(\frac{x}{a}\right) - \text{circ}\left(\frac{x}{b}\right) \right) \quad (13a)$$

$$G(\xi_x, \xi_y) = \frac{1}{2} \left(F\left(\xi_x - \frac{c}{2\pi}, \xi_y\right) + F\left(\xi_x + \frac{c}{2\pi}, \xi_y\right) + F\left(\xi_x - \frac{d}{2\pi}, \xi_y\right) + F\left(\xi_x + \frac{d}{2\pi}, \xi_y\right) \right) + C_1 F(\xi_x, \xi_y) \quad (13b)$$

[0146] In one embodiment, aperture modulation of equations (12) and (13), whereby the beam can be placed at multiple locations simultaneously or nearly simultaneously, may have limited applicability due to system, material, and/or tissue limitations. In one embodiment, due to the possibility of heating treatment area tissue(s) located before focus, the frequency of ultrasound therapy may be adjusted, such as lowered, in order to limit and/or eliminate such possibility. In one embodiment, nonlinear techniques can be applied at the focus in order to limit and/or eliminate the possibility of heating of the pre-focal tissue(s). In one embodiment, the sound pressure or ultrasound intensity from the aperture can be increased to obtain similar or substantially similar intensities at the focal plane.

[0147] In various embodiments, if the amplitude and phase functions at the aperture are separable, the two-dimensional Fourier transform of a sound pressure function $U(x_l, y_l)$ can be expressed as a product of a one-dimensional Fourier transform of two functions in x and y . In various embodiments, it may be advantageous to create multiple TCPs in a linear or substantially linear sequence as well as to create multiple linear sequences simultaneously or nearly simultaneously.

Electronic Dithering of Multiple Beam Splitting Apertures Using Frequency Modulation

[0148] In various embodiments, Table 2 illustrates aperture spatial frequency for achieving a specific distance between two simultaneous foci for a given operational frequency (e.g. in various embodiments, 4 MHz, 7 MHz, 10 MHz). Equation (11c) shows that the separation distance between the foci is also a function operational frequency. For example, in one embodiment the spatial frequency of the aperture (k_x) is fixed to 1.0 mm^{-1} and the operational frequency is allowed to vary. Equation 11c can be rewritten to show how the foci separation distance can be modulated through operation frequency.

$$s = (k_x z_f v_c) / (\pi f_{op}) \quad (14)$$

[0149] where k_x is the spatial frequency in mm^{-1} , z_f is the focal depth of the aperture in mm, v_c is the velocity of ultrasound in the propagating medium (e.g. water) in $\text{mm}/\mu\text{sec}$ and f_{op} is the operational frequency of the aperture in MHz. In one embodiment, the following substitution is made in equation 11c:

$$\lambda = v_c/f_{op} \quad (15)$$

[0150] As Equation (14) shows, the separation distance of the foci is a function of the operational frequency. Further, the rate in change of the separation distance to the operational frequency is:

$$ds/df_{op} = -(k_x z_f v_c)/(\pi f_{op}^2) \quad (16)$$

[0151] Equation (16) shows that the separation distance decreases as the operational frequency increases. Table 3 (below) shows the rate in change of separation distance as a function of operational frequency for the different spatial frequencies (e.g., in various embodiments, 4 MHz, 7 MHz, 10 MHz).

	Derivative of Equation (16) [mm/MHz]			
Ultrasound Frequency	1.1 mm	1.5 mm	2 mm	3 mm
4 MHz	-0.269	-0.367	-0.488	-0.730
7 MHz	-0.152	-0.209	-0.278	-0.418
10 MHz	-0.107	-0.146	-0.195	-0.221

Table 3

[0152] As shown in Table 3, as the operational frequency increases, the foci get closer together and as the operational frequency decreases the foci get farther apart without the need to change the phase or mechanically move the transducer. This is a unique method of electronically moving the beam to spread the energy without relying on thermal conduction in tissue. The benefits include a reduction or a minimization of the maximum temperature and an increase in the thermal coagulation volume of the lesion without the need for additional system channels.

[0153] The amount of movement from a main operational frequency can be determined by using equation (14). In one embodiment, the main operational frequency of an aperture is 5 MHz and the focal length is 15 mm. In some embodiments, the operational frequency is called the aperture center frequency. In one embodiment, the operational frequency is 5 MHz. In one embodiment, Table 4 at FIG. 5 shows the amount of foci separation for apertures with different spatial frequencies ($k_x = 0.5, 1.0, 1.5, 2.0$ in mm^{-1}) as designed for a center frequency of 5 MHz. It also calculates the amount of spread from the foci of the center frequency at 5 MHz. According to one embodiment, the spacing decreases for higher frequencies relative to 5 MHz and increases for lower frequencies relative to 5 MHz.

[0154] FIG. 6 shows the spacing difference for all operational frequencies of the aperture for different aperture spatial frequencies. As FIG. 6 shows, the separation distance increases as the frequency decreases.

[0155] In one embodiment, the separation distance is relative to a frequency 5 MHz. In one embodiment, one way to estimate the electronic dithering from frequency modulation can be determined by referencing all movement to the initial separation at 5 MHz. As FIG. 7 shows, the spread of the separation distance between the foci can easily vary by over 1 mm.

[0156] In various embodiments, the range of possible operational frequencies from one aperture can be described in terms of the transducer bandwidth. In one embodiment, a larger transducer bandwidth results in an aperture that has a wider range of operational frequencies. Transducer bandwidth can be described as a percent fraction of the aperture center frequency by locating the frequency where the transmit intensity decreases to -3 dB of the peak transmit intensity. In one embodiment the -3 dB high frequency is designated as $f_{-3\text{dB}, H}$ and the -3 dB low frequency is designated as $f_{-3\text{dB}, L}$ for the transmit response of a transducer aperture. The -3 dB center frequency in [MHz] is described as:

$$f_{-3\text{dB}, \text{center}} = (f_{-3\text{dB}, H} + f_{-3\text{dB}, L})/2 \quad (17)$$

[0157] The -3 dB percent bandwidth is described as:

$$\text{BW}_{-3\text{dB}} = 100\% * (f_{-3\text{dB}, H} - f_{-3\text{dB}, L}) / ((f_{-3\text{dB}, H} + f_{-3\text{dB}, L})/2) \quad (18)$$

[0158] In some embodiments, increasing the range of operational frequencies possible within one aperture may be achieved (but not limited to) by the use of backing layers, matching layers, multiple piezoelectric layers, electrical matching, piezoelectric composites, and/or a single crystal piezoceramic. In one embodiment, as the transducer bandwidth increases, the range of possible separation distance increases. Table 5 (below) shows how based on percent bandwidth the foci spread can vary if the aperture center frequency is 5 MHz. The foci separation distance for 5 MHz is 0.72 mm, 1.43 mm, 2.15 mm and 2.86 mm respectively for spatial frequencies of 0.5 mm^{-1} , 1.00 mm^{-1} , 1.50 mm^{-1} , 2.00 mm^{-1} . If the spatial frequency at the aperture is 1.50 mm^{-1} and the transducer bandwidth is 60%, then the separation distance between the foci varies by 1.42 mm which is a distance greater than the lateral resolution of the beam at 5 MHz.

Additional Spread from 5 MHz Center Frequency in [mm]

Bandwidth	$k_x = 0.5 \text{ mm}^{-1}$	$k_x = 1.0 \text{ mm}^{-1}$	$k_x = 1.5 \text{ mm}^{-1}$	$k_x = 2.0 \text{ mm}^{-1}$
20%	0.14	0.29	0.43	0.58
40%	0.30	0.60	0.90	1.19
60%	0.47	0.94	1.42	1.89
80%	0.68	1.36	2.05	2.73
100%	0.95	1.91	2.86	3.82

Table 5

[0159] In one embodiment, as the frequency is changed, the depth-of-field will also change as well as lateral resolution and focal gain. In one embodiment, as the frequency is changed, the depth-of-field, lateral resolution and focal gain will also change. Therefore, in one embodiment, the intensity at the aperture may change depending in the heating rate goals. Also, in some embodiments, it may be advantageous to send multiple operational frequencies at the same time to spread the energy immediately or near-immediately. For example, transmit excitation of the aperture may include excitation at 4 MHz, 5 MHz and 6 MHz all at the same time.

Multiple Foci By Changing the Aperture Spatial Frequency

[0160] As Equation 14 shows, the higher the aperture spatial frequency, the greater the separation distance between the foci. In one embodiment, an aperture is poled

with a spatial frequency of k_x . The spatial frequency can be easily doubled or decreased to zero by connecting individual electrical excitation channels that have the ability to modify the phase to 0 degrees or 180 degrees, as shown in the embodiments in FIG. 8. For example, if the phase on channels 1 through 16 is 0 degrees, then the aperture spatial frequency is k_x . In an embodiment, as the phase on each channel is varied from 0 degrees to 180 degrees such that odd channels are at 0 degrees and even channels are at 180 degrees, then the spatial frequency at the aperture is $\frac{1}{2} k_x$. In an embodiment, if the phase repeats every two channels such that channel 1 and channel 2 is 0 degrees and channel 3 and channel 4 is 180 degrees and so on, then the spatial frequency at the aperture is 0. If channel 1 is 0 degrees, channel 2 is 180 degrees, channel 3 is 180 degrees, channel 4 is 0 degrees and so on, then the spatial frequency at the aperture is $2k_x$. In this case, seven unique foci can be created. As noted in Table 4 (at FIG. 5), if the aperture center frequency is 5 MHz, and the aperture frequency is any of 0 mm^{-1} , 0.5 mm^{-1} , 1.0 mm^{-1} , or 2.0 mm^{-1} , the corresponding separation distances are 0 mm, 0.72 mm, 1.43 mm and 2.86 mm, which yield seven unique focal positions separated by 0.36 mm. In various embodiments, intermediate phases between 0 degrees and 180 degrees would further allow the two foci to be tilted such that a line of foci could be created at the focal plane. Ultimately, the tilting, modulation of focal position, and frequency modulation enables the heating and possible coagulation of an entire line with a length of approximately 2.86 mm.

[0161] In one embodiment, a poled ceramic has a spatial frequency of $2k_x$, as shown in FIG. 9. In this case, each electrical channel covers two poled areas in the ceramic (e.g., a piezoceramic). If channel 1 through channel 8 have the same electrical phase, then the spatial frequency of the aperture is $2k_x$. If the phase alternates such that odd channels have a phase of 0 degrees and even channels have a phase of 180 degrees, then the spatial frequency of the aperture is k_x . In one embodiment, this configuration of only two phases are possible on the channels enables four unique foci. In various embodiments, if additional phases are allowable then it is possible to tilt the two foci to many different focal positions. This configuration limits the number of required electronic channels to get multiple foci positions.

[0162] In several embodiments, a treatment system utilizes multiple therapy channels to enable electronic focusing and/or steering. For example, a treatment system that

utilizes multiple therapy channels to enable electronic focusing and/or steering allows for faster electronic dithering to either create more thermal coagulation using the same amount of energy as other treatment devices or equal thermal coagulation using electronic dithering with less energy than other treatment devices. This technique broadens the efficacy and comfort continuum that the device offers. In addition to electronic dithering, the multiple therapy channels also offer the possibility to move the beam to different depth locations such that two conventional transducers such as the DS7-4.5 (7 MHz at 4.5 mm depth) and DS7-3.0 (7 MHz at 3.0 mm depth) could be replaced by one single device that moves between the two different depths.

[0163] In one embodiment, a transducer 280 with multiple therapy channels 281 connected to move the beam axially (e.g. annular array) would typically create a TCP 550 at a deep depth first and then move to the shallower depth. In another embodiment, a TCP 550 is created at a shallow depth and then at a deeper depth below the skin surface. This creates the TCP 550 sequentially and would cause the treatment time to be extended. For example, in one embodiment, if the time for the deep TCP 550 is t_{deep} and the time for the shallow TCP 550 is t_{shallow} , then the total treatment time for the two TCPs 550 is the sum of the two treatment times, t_{deep} plus t_{shallow} . In one embodiment, total treatment time is reduced by forming multiple (two, or more) TCP's 550 simultaneously using signal mixing techniques which uses both signal apodization (shading) and phase control at each channel. In one embodiment, the total treatment time is the maximum of t_{deep} and t_{shallow} :

[0164] Treatment time, conventional approach: $t_{\text{treatment}} = t_{\text{deep}} + t_{\text{shallow}}$

[0165] Treatment time, signal mixing: $t_{\text{treatment}} = \max(t_{\text{deep}}, t_{\text{shallow}})$

[0166] In an embodiment, an annular array design 280 enables the electronic movement of the therapy beam in depth (e.g., by changing depth of the TCP 550 below the skin surface). In one embodiment, a transducer 280 includes an eight therapy channel annular transducers elements 281 with a fixed mechanical focus. FIG. 10 shows a top view of one embodiment of this ceramic annular array design 280 with an imaging transducer 285 at the center of the bowl. In this embodiment, the therapy annular transducer 280 has eight rings identified as Tx0 though Tx7, corresponding to the elements 281.

Transducers

[0167] In one embodiment, transducer 280 is spherically focused to one or more points. In one embodiment, transducer 280 is cylindrically focused to one or more lines. Various embodiment of transducer 280 include a flat piezoelectric with a lens. In various embodiments, transducer 280 comprises a convex side 282 and a concave side 283. In various embodiments, a transducer 280 comprises a convex side 282 and a concave side 283 with features that provide for any one or more of variable depth, variable spacing, variable focus positioning, with one, two, three, four, or more simultaneous focus zones. In various embodiments, a transducer 280 is electrically connected to one or more tuning circuits. The tuning circuit improves the electrical signal between the console and the transducer. In various embodiments, one or more tuning circuits is located in the housing of the transducer, in the connection between the transducer and a console, and/or in the console.

[0168] Fig. 11 illustrates an embodiment of a transducer 280 comprising a single element with a convex side 282 and a concave side 283. Fig. 12 illustrates an embodiment of a transducer 280 comprising a solid, coated a convex side 282 and a striped a concave side 283, where the stripes comprise first poled and second poled regions, wherein a poled region is a positive, negative, or unpoled. Fig. 12 illustrates an embodiment of a transducer 280 comprising a solid, coated a convex side 282 and a striped a concave side 283, where the stripes comprise first regions and second regions, wherein a region can comprise a coating or no coating. In one embodiment, a single electrode is provided on the convex surface with poled stripes on concave surface connected to two channels (e.g., Fig. 12). The stripes can alternate to split the beam or include just one phase to mimic the conventional transducer. This would permit one transducer to mimic the treatment of the DS4-4.5S and the DS4-4.5 so three lines can be created with one transducer placement.

[0169] Fig. 13 illustrates an embodiment of a transducer 280 comprising a striped convex side 282 and a solid, coated concave side 283, where the stripes comprise first poled and second poled regions, wherein a poled region is a positive, negative, or unpoled. Fig. 13 illustrates an embodiment of a transducer 280 comprising a striped convex side 282 and a solid, coated concave side 283, where the stripes comprise first regions and second regions, wherein a region can comprising a coating or no coating. In various embodiments, the stripes are electrically connected to a one or more channels. In one embodiment, odd stripes are

connected to a first channel and even stripes are connected to a second channel. In one embodiment, the first channel remains at 0° while the second channel alternates between 0° and 180° (or vice versa). Focused ultrasound energy from the first channel remains at a single, central location, which focused ultrasound energy from the second (alternating) channel produces two spaced apart focal zones. Together, the focused ultrasound energy from the first (constant) and second (alternating) channels produces three simultaneous TCP's. In one embodiment, a single electrode is provided on the concave surface with poled stripes on convex surface connected to two channels (e.g., Fig. 13). The stripes can alternate to split the beam or include just one phase to mimic the conventional transducer. This would permit one transducer to mimic the treatment of the DS4-4.5S and the DS4-4.5 so three lines can be created with one transducer placement.

[0170] Fig. 14 illustrates an embodiment of a transducer 280 comprising a striped convex side 282 and a striped concave side 283, where the stripes comprise first poled and second poled regions, wherein a poled region is a positive, negative, or unpoled, wherein the striped regions are rotated in an orientation of about 90 degrees with respect to each other. Fig. 14 illustrates an embodiment of a transducer 280 comprising a striped convex side 282 and a solid, coated concave side 283, where the stripes comprise first regions and second regions, wherein a region can comprising a coating or no coating, and wherein the stripes are rotated about 90 degrees with respect to each other.

[0171] Fig. 15 illustrates an embodiment of a transducer 280 comprising a striped convex side 282 and an annular concave side 283, where the stripes comprise first poled and second poled regions, wherein a poled region is a positive, negative, or unpoled. Fig. 15 illustrates an embodiment of a transducer 280 comprising a striped convex side 282 and an annular concave side 283, where the stripes comprise first regions and second regions, wherein a region can comprising a coating or no coating.

[0172] Fig. 16 illustrates an embodiment of a transducer 280 comprising an annular convex side 282 and a striped concave side 283, where the stripes comprise first poled and second poled regions, wherein a poled region is a positive, negative, or unpoled. Fig. 16 illustrates an embodiment of a transducer 280 comprising an annular convex side 282

and a striped concave side 283, where the stripes comprise first regions and second regions, wherein a region can comprising a coating or no coating.

[0173] In some embodiments, the system comprises various features that are present as single features (as opposed to multiple features). For example, in one embodiment, the system comprises, consists essentially of, or consists of a single ultrasound transduction element that is adapted to provide two simultaneous treatment zones via dithering. Multiple features or components are provided in alternate embodiments

Simultaneous Therapy at Multiple Depths

[0174] In various embodiments, a treatment system is configured to produces a plurality of regions of microcoagulation in tissue separated by equal distances along a line of mechanical motion. In various embodiments, a treatment system provides different modules, cartridges, or different transducers (e.g., DS4-4.5, DS7-4.5, DS7-3.0, DS10-1.5, DS7-3.0N, DS10-1.5N, or OT4-4.5, OT7-4.5, OT7-3.0, OT10-1.5, wherein a first number represents the therapy frequency and the second number represents a depth of therapy delivery. The 'N' for the last two transducers designates this device as a narrow transducer which is used in hard to reach areas such as around the nose and mouth. The first four transducers can deliver therapy along a 25 mm line whereas the narrow transducers offer a maximum line length of 14 mm). In various embodiments, a transducer with annular electrodes and poled ceramic enables frequency dithering in lateral dimension, electronic dithering in depth dimension, electronic focusing in depth dimension and a single transducer that can mimic the DS10-1.5 (10 MHz at 1.5 mm depth), DS7-3.0 (7 MHz at 3.0 mm depth), DS7-4.5 (7 MHz at 4.5 mm depth), and DS4-4.5 (4 MHz at 4.5 mm depth) in one transducer. In one embodiment, selectable tuning electronics may be used in combination with composite ceramic to enable the function of the transducer with annular electrodes and poled ceramic enables frequency dithering in lateral dimension, electronic dithering in depth dimension, electronic focusing in depth dimension. In various embodiments, one, two, three, or more selectable tuning circuits help stabilize the signal between the console and the transducer, and can be presented in the transducer housing, between a transducer and a console, or in the console.

[0175] In one embodiment a full-face treatment delivers 800 lines of treatment with a transducer involving an operator moving a handpiece along a patient's skin in about 70

to 90 minutes. In one embodiment, a single therapy bowl is configured for the simultaneous delivery of two therapy lines (e.g., DS4-4.5S, DS4-3.0S, OT4-4.5S or OT4-3.0S, which can reduce the treatment delivery time by approximately 40% based on a recent clinical study. In various embodiments, the treatment devices offer a comparable level of efficacy if operated at the correct energy. In various embodiments, a simultaneous treatment reduces the overall pain of a treatment. In one embodiment, a simultaneous treatment time is significantly reduced, it has been hypothesized that the overall pain of the treatment is less.

[0176] In various embodiments, a simultaneous treatment will increase a treatment speed by 10%, 20%, 25%, 30%, 40%, 50%, 60% or more. In various embodiments, a simultaneous treatment will reduce a treatment time by 10%, 20%, 25%, 30%, 40%, 50%, 60% or more. In various embodiments, a system is configured to complete a treatment time in 60, 50, 40, 30, 20, or 10 minutes or less.

[0177] In one embodiment, a simultaneous treatment system creates two lines simultaneously with the ability to move the depth of the microcoagulation at thermal coagulation zone 550. In one embodiment, the bandwidth of the therapy transducer is increased, then it is possible to have one device that behaves like two, three, four, five, or six fixed-depth devices. In one embodiment, an 8-channel therapy device is used.

[0178] Fig. 17 illustrates an embodiment of a transducer 280 comprising an annular convex side 282 and a striped concave side 283, where the stripes comprise first poled and second poled regions, wherein a poled region is a positive, negative, or unpoled. Fig. 17 illustrates an embodiment of a transducer 280 comprising an annular convex side 282 and a striped concave side 283, where the stripes comprise first regions and second regions, wherein a region can comprising a coating or no coating. In one embodiment, an annular array coupled with a simultaneous transducer enables two lines of focused ultrasound treatment to be generated simultaneously at different depths 279 (e.g., D_1 , D_2 , D_3 , ... D_N) below a skin surface. In one embodiment, the stripes on concave side 283 are alternatively poled (e.g., at 0 degrees and 180 degrees, etc.). In various embodiments, depth 279 is 1.5 mm, 3.0 mm, 4.0 mm, 4.5 mm, or 7 mm. In one embodiment, $D_1 = 1.5\text{mm}$, $D_2 = 3.0\text{mm}$, and $D = 4.5\text{ mm}$. In various embodiments, depth 279 is 0.5 mm, 1.0 mm, 1.5 mm, 2 mm, 3 mm, 4 mm, 4.5 mm, 6 mm, 7 mm, less than 3 mm, between 0.5 mm and 5 mm, between 1.5 mm and

4.5 mm, more than more than 4.5 mm, more than 6 mm, 7 mm, and anywhere in the ranges of 0.1 mm - 3 mm, 0.1 mm - 4.5 mm, 0.1 mm - 25 mm, 0.1 mm - 100 mm, and any depths therein (e.g., 6 mm, 7 mm, 10 mm, 13 mm, 15 mm, 17 mm). In an embodiment, a simultaneous treatment at multiple depths creates multiple thermal coagulation zones 550 at various depths 279. Fig. 17 shows the two sides of an embodiment of a simultaneous therapy bowl. On one side of the therapy bowl are stripes that are used to perform alternating poling. In one embodiment, the stripes are on the concave side 283. In one embodiment, the stripes are on the convex side 282. In one embodiment, after the poling is done, the electrode is stripped and a complete electrode is placed over the entire side. In one embodiment, a cold silver electrode may also be used to connect the stripes. In one embodiment, an opposite side of the therapy bowl comprises concentric rings which may or may not be of equal area. The annular array enables beam movement in depth when the correct phasing is applied to the therapy bowl.

[0179] In one embodiment, a transducer 280 comprising an annular convex side 282 and a striped concave side 283 is configured to produce multiple depth thermal coagulation zones 550 at various depths 279, as shown in Figs. 18 (projection in x-y-z space), 19 (x-z plane) and 20 (y-z plane). Fig. 18 shows a three dimensional sketch of the microcoagulation points. In one embodiment, two, three, four, or more points may be generated simultaneously. In one embodiment, two points are generated simultaneously. In one embodiment, it is expected the deeper microcoagulation points would be created first (e.g., 4.5mm) before moving to the next depth (e.g., 3.0 mm) and then finally to the shallowest depth (e.g., 1.5mm). In one embodiment, the motion mechanism moves left-to-right and right-to-left. In one embodiment, a temperature of the skin may be limited by forming the microcoagulation points at the deepest depth (e.g., 4.5mm) when moving left-to-right and then placing the next depth (e.g., 3.0mm) when moving right-to-left and then completing the treatment at with the microcoagulation points at the shallowest depth (e.g., 1.5mm) when moving left-to-right again. Fig. 19 shows a projection of the treatment along the direction of mechanical motion (x-axis) and depth (z-axis). Fig. 20 shows a projection of the treatment along the direction where the beam is split (y-axis) and depth (z-axis).

[0180] Figs. 21-23 illustrate an embodiment of a simultaneous multiple depth treatment device configured to create TCP's at depths of 1.5 mm, 3.0 mm, and 4.5 mm, wherein the middle layer is offset from the deep and shallow depths. In one embodiment, a transducer 280 comprising an annular convex side 282 and a striped concave side 283 is configured to produce multiple depth thermal coagulation zones 550 at various depths 279, as shown in Figs. 21 (projection in x-y-z space), 22 (x-z plane) and 23 (y-z plane). In one embodiment, the length of the TCP may limit the ability to stack multiple depth TCP's directly on top of each other. In one embodiment, the motion mechanism offsets the different depth TCPs treatments from each other. Fig. 21 shows the three dimensional drawing of the offset multiple depth transducers. A similar process of delivery which was described for Figs. 18 - 20 a may be applied in with the embodiment in Figs. 21-23, wherein the microcoagulation points may be delivered when moving left-to-right or right-to-left to minimize the possibility any potential injury to the epidermis or dermis or tissue layers. Fig. 22 shows a projection of the delivery along the mechanical motion (x-axis) and depth (z-axis). This clearly shows the middle layer of TCP' s offset from the deep and shallow treatments. Fig. 23 shows a projection of the delivery along the direction where the beam is split (y-axis) and depth (z-axis).

[0181] Figs. 24-26 illustrate an embodiment of a simultaneous multiple depth treatment device configured to create TCP's at depths of 1.5 mm, 3.0 mm, and 4.5 mm, wherein the middle layer is offset from the shallow depth with varying pitches. In one embodiment, a motion mechanism can be used to match the separation distance between the TCPs in the single line treatments. Figs. 24-26 show a three dimensional sketch of the multi-depth simultaneous treatment. In this case in an embodiment, the 4.5 mm depth treatment is delivered at one pitch (1.5mm apart) whereas the 3.0 mm depth and 1.5 mm depth treatments are delivered at another pitch (e.g. 1.1 mm apart). Although the 1.5 mm depth and 3 .0 mm depth treatments are at the same pitch (e.g. 1.1 mm), the motion mechanism allows an offset to be applied to prevent stacking of the microcoagulation points. Fig. 25 shows a projection of the delivery along the mechanical motion (x-axis) and depth (z-axis). This clearly shows the middle layer of TCP's offset from the shallow treatment even though the pitch is the same. Similarly, the deepest treatment is at a slightly larger pitch relative to the two other

depths. Fig. 26 shows a projection of the delivery along the direction where the beam is split (y-axis) and depth (z-axis).

[0182] In various embodiments, a transducer 280 comprising an annular convex side 282 and a striped concave side 283 (such as shown in Fig. 16 and/or Fig. 17), produces a treatment pattern shown in embodiments of Figs. 25, 26, and/or 29. In an embodiment, transducer 280 with an annular convex side 282 and a striped concave side 283 produces an intensity peaks near the center of the focal zone when viewed in an projection in x-y-z space (such as in Figs. 18 and 19) where control of each ring in the annular convex side 282 has an amplitude (A) and a phase (θ). In this case, poling based on the stripes creates simultaneous foci at one depth. In order to create the simultaneous foci at each depth as shown in Figures 18 and 19, different phases (θ) and different amplitudes (A) are applied to each ring in order to produce the simultaneous foci at the different depths. The different phases enable the two foci to move to different focal depths and the different amplitudes allow the focal intensity to vary and thus the heating rate in tissue. The amount of separation between the two foci at the same depth along the Y axis is determined by the frequency, focal depth, and spatial frequency of the stripes (See equation 14 where it is solved for s). The transducer may be manually or mechanically moved to precisely space the simultaneous foci along the X axis. In one embodiment, a middle ring has an amplitude A_1 greater than the next outer ring with an amplitude A_2 , which is greater than A_3 , ... until the outer most ring amplitude A_n , creating a wider intensity range and the ability to shape to two foci that appear simultaneously. This control of the amplitude allows the width of the beam at the two foci to vary as well as the intensity which affects the heating rate.

[0183] In various embodiments, a continuous wave function may be used to produce simultaneous focal zones at different depths below a skin surface combining excitation functions for focal solution with another solution. In one embodiment, a focal zone (f_1) at a first depth (d_1) is simultaneously produced with a second focal zone (f_2) at a second depth (d_2) that is different than the first depth (d_1). Both foci at different depths (d_1 and d_2) may be produced simultaneously via linear systems combine excitation to a single ultrasound transduction element. The table below show two sets of amplitudes and phases required for each focal zone and depth. Since these two excitations are occurring at the same frequency, it

is possible to combine the two excitations on each ring to one amplitude and one phase.

Suppose the excitation on ring number 1 for focus #1 is written as:

$$x_{1,1}(t) = A_{1,1} \sin(\omega t + \theta_{1,1})$$

[0184] Suppose the excitation on ring number 1 for focus #2 is written as:

$$x_{1,2}(t) = A_{1,2} \sin(\omega t + \theta_{1,2})$$

[0185] where ω is $2\pi f$ where f is the frequency and t is time.

RING NUMBER	FOCUS #1 (f_1) at a depth (d_1)		FOCUS #2 (f_2) at a depth (d_2)	
	Amplitude	Phase	Amplitude	Phase
1	$A_{1,1}$	$\theta_{1,1}$	$A_{1,2}$	$\theta_{1,2}$
2	$A_{2,1}$	$\theta_{2,1}$	$A_{2,2}$	$\theta_{2,2}$
3	$A_{3,1}$	$\theta_{3,1}$	$A_{3,2}$	$\theta_{3,2}$
4	$A_{4,1}$	$\theta_{4,1}$	$A_{4,2}$	$\theta_{4,2}$
5	$A_{5,1}$	$\theta_{5,1}$	$A_{5,2}$	$\theta_{5,2}$
6	$A_{6,1}$	$\theta_{6,1}$	$A_{6,2}$	$\theta_{6,2}$
7	$A_{7,1}$	$\theta_{7,1}$	$A_{7,2}$	$\theta_{7,2}$
8	$A_{8,1}$	$\theta_{8,1}$	$A_{8,2}$	$\theta_{8,2}$

In order to produce two foci simultaneously at two different depths, then the two excitations to the first ring must be combined:

$$X_1(t) = x_{1,1}(t) + x_{1,2}(t) = A_{1,1} \sin(\omega t + \theta_{1,1}) + A_{1,2} \sin(\omega t + \theta_{1,2})$$

[0186] However, even though this is the necessary excitation on ring 1, it is unclear the actual amplitude and phase that is required on the ring to properly excite for both f_1 and f_2 at the same time. In order to determine this new Amplitude (Λ_1) and new phase (Ω_1) for the combined effect, the following trigonometric identity is applied:

$$\Lambda_1 = \sqrt{[A_{1,1} \cos(\theta_{1,1}) + A_{1,2} \cos(\theta_{1,2})]^2 + [A_{1,1} \sin(\theta_{1,1}) + A_{1,2} \sin(\theta_{1,2})]^2}$$

$$\Omega_1 = \tan^{-1}[(A_{1,1} \sin(\theta_{1,1}) + A_{1,2} \sin(\theta_{1,2})) / (A_{1,1} \cos(\theta_{1,1}) + A_{1,2} \cos(\theta_{1,2}))]$$

[0187] such that the new excitation on ring 1 is:

$$X_1(t) = \Lambda_1 \sin(\omega t + \Omega_1)$$

[0188] This same process can be applied to the other rings to obtain the array solution to create f_1 and f_2 simultaneously. Similarly, if the desire is to deliver three or more foci simultaneously, then the process can be repeated using the above identity until only one excitation and one phase is computed for each ring. For example, suppose that the goal was to create three foci simultaneously, then the initial new amplitudes and new phases for each ring are computed based on the amplitudes and phases required for focus 1 and focus 2. Next, these new amplitudes and phases are combined with the ring excitations necessary for focus 3.

[0189] Although it is possible to create simultaneous foci using this methodology, the necessary amplitudes may be limited by saturation of the piezoelectric material as well as the ability of the tissue to absorb the increased intensities in the surrounding tissue when generating multiple foci. These physical limitations must be compared against the time advantages of generating the foci simultaneously.

[0190] Figs. 27-29 illustrate an embodiment of a simultaneous multiple depth treatment device configured to create TCP's at depths of 1.5 mm, 3.0 mm, and 4.5 mm, wherein the middle layer is offset from the shallow depth and frequency is used to create different separation distances at each depth. In Figs. 24-26, the middle depth of TCPs are offset from the deepest and shallowest depth using the motion mechanism. In various embodiments, the amount of separation between the simultaneously created TCPs is dependent on the treatment frequency. In one embodiment, the device is able to deliver therapy at multiple frequencies (e.g., with a broad bandwidth therapy transducer), and it is possible to modulate the distance between the TCPs using frequency. As discussed with Fig. 18, the spacing of the stripes are determined upon manufacture since this is created through ceramic poling. Lower frequencies and a deeper depth create a wider separation between the

simultaneously created TCPs (y-z plane). Figure 4a shows the three dimensional matrix of TCPs with this varying degree of separation. As the frequency is increased for the shallower depths and the depth of treatment is reduced, the distance between the simultaneously created TCPs decreases. Fig. 28 shows a projection of the delivery along the mechanical motion (x-axis) and depth (z-axis). This clearly shows the middle layer of TCP's offset from the shallow and deep treatments even though the pitch is the same. Fig. 29 shows a projection of the delivery along the direction where the beam is split (y-axis) and depth (z-axis). This projection shows the spacing between the TCPs gets progressively larger as the depth of treatment increases which is primarily due to depth and frequency changes in treatment.

[0191] In one embodiment, as shown in Fig. 29, different spacing can be produced by changing frequencies and focal depth. For example, equation 14 is:

$$[0192] \quad s = (2 k_x z_f \lambda) / (2 \pi)$$

[0193] Where s is the spacing between the two simultaneous foci at the same depth. The equation shows that the foci separation is a function of focal depth (z_f) and frequency (since λ is speed of sound divided by frequency). Suppose the same frequency and spatial frequency on the stripe is used. The table summarizes the separation for the different foci which are separated by 1.5 mm.

z _f (mm)	frequency (MHz)	wavelength (mm)	k _x (mm ⁻¹)	s (mm)
15.5	7	0.22	1.5	1.628
17	7	0.22	1.5	1.786
18.5	7	0.22	1.5	1.943

[0194] However, if the frequency varies such that the higher frequency is used for the shallowest focus, then a much broader range of separation distances is achievable:

z _f (mm)	frequency (MHz)	wavelength (mm)	k _x (mm ⁻¹)	s (mm)
15.5	10	0.154	1.5	1.140
17	7	0.22	1.5	1.786

18.5	4	0.385	1.5	3.401
------	---	-------	-----	-------

[0195] In various embodiments, different w (e.g., w_1, w_2) may be used to vary the distance or spacing. In various embodiments, a continuous wave function may be used to produce simultaneous focal zones at different depths below a skin surface combining frequencies with Fourier transforms. In one embodiment, a focal zone (f_1) at a first depth (d_1) is simultaneously produced with a second focal zone (f_2) at a second depth (d_2) that is different than the first depth (d_1). Both foci at different depths (d_1 and d_2) may be produced simultaneously via linear systems combine excitation to a single ultrasound transduction element.

$\frac{f_1}{A_{1,1} / \theta_{1,1}}$	$\frac{f_2}{A_{1,2} / \theta_{1,2}}$
$A_{2,1} / \theta_{2,1}$	$A_{2,2} / \theta_{2,2}$
$A_{3,1} / \theta_{3,1}$	$A_{3,2} / \theta_{3,2}$
$A_{4,1} / \theta_{4,1}$	$A_{4,2} / \theta_{4,2}$

where $X_1 = \text{excitation } (A, \theta) = A_{1,1} \sin (w_1t - \theta_{1,1}) A_{1,2} \sin (w_2t - \theta_{1,2})$

to produce two simultaneous foci at a varying distances.

[0196] In various embodiments, electrostrictors exhibit piezoelectric behavior when a sufficient DC bias is placed upon the material. In one embodiment, the strength of the piezoelectric behavior is proportional to the acoustic sensitivity. In one embodiment, the electrostrictor material is used with the therapy bowl in the manufacturing process. In one embodiment, patterning and electrode attachment is achieved during manufacturing, but the poling of the electrostrictor is accomplished during the therapy delivery. For example, in one embodiment, the transmit aperture may be a square wave as shown in Fig. 37 or shaded through modification of the high voltage value. Fig. 30 illustrates an embodiment of a simultaneous multiple depth treatment device configured to create TCP's at depths of 1.5 mm, 3.0 mm, and 4.5 mm, wherein an annular array is coupled with an electrostrictor that enables multiple pairs to be generated simultaneously at different depths. In one embodiment, an electrostrictor changes the spatial frequency (such as shown in one embodiment in Fig. 37) providing for creating a line of treatment (such as shown in one embodiment in Fig. 34). In

one embodiment, the electrostrictor produces a line of treatment without employing a mechanical motion mechanism. In one embodiment, the electrostrictor produces lines perpendicular to the motion of a mechanical motion mechanism. Thus, in various embodiments, a multidimensional treatment can create one, two, or more treatment focal zones in various spacing, lines, planes, or three dimensional spaces. In some embodiments, an electrostrictor results in the displacement of ions in the crystal lattice of the piezoelectric transducer upon being exposed to an external electric field. In various embodiments, Figs. 17-29 have a fixed poling pattern to yield a separation distance between the two simultaneously created TCPs. This is because the poling pattern is created in a piezoelectric ceramic during fabrication. The spacing between the stripes determines the spacing between the TCPs. The larger the distance between the stripes, the closer the TCPs are. In some embodiments, there is no ability after the poling is completed to change the distance between the stripes. In one embodiment, as shown in Figs. 30 – 33, an electrostrictor material does not involve poling, but instead uses an electrostrictor to apply a direct current (DC) voltage during device operation to exhibit piezoelectric behavior which can be used to improve device performance. Figure Sa shows the front and back (e.g., concave and convex sides) of the ceramic bowl which is similar to the embodiment shown in Fig. 17. In one embodiment, an annular pattern is on the back (e.g., convex side) of the transducer. The front side (patient side, e.g., concave side) is slightly different when compared to the embodiment in Fig. 17, e.g., the stripes appear to be created at a finer pitch. Second, the ceramic is not poled, but connections from each individual stripe are connected to a separate bank of electronics to place a voltage across the stripe to create the appropriate pattern that yields a separation distance between the TCPs. In one embodiment, the voltage varies at a high spatial frequency, resulting in a larger separation distance is created between the TCPs. The electronics allows this pattern to be varied such that the distance between the TCPs may also be varied. The result is a collection of simultaneous TCPs which can be created through this amplitude modulation. It is not necessary to place a negative or positive voltage on each stripe. In some embodiments, shorting the stripe to ground prevents or reduces acoustic excitation. Fig. 31 illustrates an embodiment of the type of TCP distribution that can be created three dimensionally. In an embodiment, five TCPs at each depth are created which is

accomplished with three different DC amplitude modulation patterns on the stripes. Again, the order may be varied within a depth 279 or at each depth based on the movement of the motion mechanism either left to right or right to left, modulation pattern, and focusing of the rings. The order used is based on the safety tolerance of the epidermis and dermis and any other tissue layer, along with the goal to deliver the TCP as quickly as possible. Fig. 32 illustrates a projection of the delivery along the mechanical motion (x-axis) and depth (z-axis). Fig. 33 shows a projection of the delivery along the direction where the beam is split (y-axis) and depth (z-axis). This projection shows the five TCPs created in this plane. Two pairs of TCPs are created simultaneously where one is created at one time similar to the conventional transducers. In various embodiments, the techniques discussed with the embodiments of Figs. 21 - 29 are applicable for the electrostrictor design.

[0197] Figs. 34-36 illustrate an embodiment of a simultaneous multiple depth treatment device configured to create TCP's at depths of 1.5 mm, 3.0 mm, and 4.5 mm, with an annular array coupled with a simultaneous treatment transducer enables two lines to be generated simultaneously at different depths. In one embodiment, an advantage of using an electrostrictor with enough stripes is the ability to create a thermal line of therapy if the pattern is rapidly changed. Fig. 34 illustrates an embodiment showing a line of TCPs in three dimensions created using multiple spatial frequencies for the electrostrictor pattern at only one depth. Depending on the rate of pattern change across the stripes, this heating can be varied to create a line of microcoagulation or a line of elevated temperature is tissue for cell apoptosis. Fig. 35 shows the projection to the x-z plane which accounts for five lines. Fig. 36 shows the projection to the y-z plane which shows that a line of heating along the y-axis at a specific depth.

[0198] In one embodiment, Fig. 37 shows different patterns that can be generated when the stripes are fine pitched. In Fig. 37, the X-axis represents the distance across a transducer. The Y-axis represents the amplitude of DC at the location across the transducer . Various DC signals applied across the transducer can result, in various embodiments, of different spacing between foci. In one embodiment, a fine pitch is related to the distance of the split that is trying to be achieved, operational frequency, focal depth. In various embodiments, a fine pitch is between 0.1 mm to 0.05 mm (e.g., 100 microns to 50 microns,

including 90, 80, 70, 60 microns and any values therein). The figure shows the amplitude modulation that is possible along the y-axis to yield a different spacing for the microcoagulation points. Although the figure covers factor of 2 multiples, it is possible to have other modulation patterns which are between the multiples shown. It is not necessary that the modulation patterns are whole numbers of the 1x pattern. In various embodiments, even, odd and null patterns are possible. Finally, the electrostrictor methodology also offers the possibility to modulate the amplitude pattern since the polarization is a strong function of the DC bias.

[0199] Various advantages of the embodiments of a simultaneous multiple depth treatment device configured to create multiple TCP's at various depths include the creation of simultaneous TCPs at multiple depths. In one embodiment, an advantage is the elimination of multiple transducers, thereby reducing the transducer swapping by the operator. In one embodiment, an advantage is faster treatment time. In one embodiment, an advantage is fewer button presses deliver the same number of lines. In one embodiment, an advantage is modulation of the distance between the TCPs delivered simultaneously. In one embodiment, an advantage is maintaining the pitch separation of the TCPs at each depth along the line of mechanical motion. In one embodiment, an advantage is the avoidance of pulse stacking at multiple depths. In one embodiment, an advantage is the ability to create larger zones of coagulation and apoptosis. In one embodiment, an advantage is enabling the ability to deliver lines of microcoagulation along three dimensions. In one embodiment, an advantage of using an electrostrictor, includes creating more than two lines with one transducer placement on a patient's body. In one embodiment, an advantage of using an electrostrictor is modulating the distance between the simultaneously delivered TCPs. In one embodiment, an advantage is modulating the ability to mute spatial high frequency harmonics from the simultaneous therapy modulation pattern. In one embodiment, an advantage of using an electrostrictor offers the possibility of adding nulls to the modulation pattern.

Example Embodiments

[0200] The following examples are non-limiting embodiments.

[0201] In some embodiments, an ultrasound treatment system for creating multiple focus points and different depths with an ultrasound transducer is provided, comprising: an ultrasonic probe comprising an ultrasound transducer configured to apply ultrasonic therapy to tissue at a plurality of locations with at least two focal depths with at least one of the group consisting of amplitude modulation, poling and phase shifting; a movement mechanism configured to be programmed to provide spacing between the plurality of individual cosmetic treatment zones; wherein the wherein a sequence of individual cosmetic treatment zones has a treatment spacing in a range from 1 mm to 50 mm and a control module coupled to the ultrasonic probe for controlling the ultrasound transducer, wherein the ultrasonic transducer is configured to provide an acoustic power of the ultrasonic therapy in a range of between 10W to 1000W and a frequency of 1 MHz to 20 MHz to thermally heat the tissue to cause coagulation. The plurality of locations may be positioned in a substantially linear sequence within a cosmetic treatment zone and the ultrasound transducer comprises a single ultrasound transduction element. In one embodiment, a first set of locations is positioned within a first cosmetic treatment zone and a second set of locations is positioned within a second cosmetic treatment zone, the first zone being different from the second zone. The first cosmetic treatment zone may comprise a substantially linear sequence of the first set of locations and the second cosmetic treatment zone may comprise a substantially linear sequence of the second set of locations.

[0202] The ultrasound transducer is configured, in one embodiment, to apply ultrasonic therapy using amplitude modulation whereby a plurality of portions of the ultrasound transducer are configured to emit ultrasonic therapy at a plurality of amplitudes of acoustic intensity, wherein a first amplitude is different than a second amplitude. In one embodiment, the ultrasound transducer is configured to apply ultrasonic therapy phase shifting whereby a plurality of portions of the ultrasound transducer are configured to emit ultrasonic therapy at a plurality of phases of acoustic intensity, wherein a first phase is different than a second phase. In one embodiment, the ultrasound transducer is configured to apply ultrasonic therapy using amplitude modulation whereby a plurality of portions of the ultrasound transducer are configured to emit ultrasonic therapy at a plurality of amplitudes of acoustic intensity, wherein a first amplitude is different than a second amplitude; and apply

ultrasonic therapy phase shifting whereby a plurality of portions of the ultrasound transducer are configured to emit ultrasonic therapy at a plurality of phases of acoustic intensity, wherein a first phase is different than a second phase. The plurality of phases may comprise discrete phase values. The ultrasound transducer may comprise piezoelectric material and the plurality of portions of the ultrasound transducer can be configured to create a plurality of corresponding piezoelectric material variations in response to an electric field applied to the ultrasound transducer. In one embodiment, the plurality of piezoelectric material variations comprise at least one of expansion of the piezoelectric material and contraction of the piezoelectric material. The ultrasound treatment system may have at least one portion of the ultrasonic transducer is configured to emit ultrasonic therapy at two or more amplitudes of acoustic intensity, and wherein the amplitude of ultrasonic therapy emitted by the at least one portion of the piezoelectric varies over time. In one embodiment, the movement mechanism is configured to be programmed to provide variable spacing between the plurality of individual cosmetic treatment zones, further comprising one or more selectable tuning circuits. The ultrasound treatment system may include a sequence of individual cosmetic treatment zones has a treatment spacing in a range from 1 mm to 25 mm, further comprising a tuning circuit. In one embodiment, the ultrasonic treatment is at least one of a face lift, a brow lift, a chin lift, an eye treatment, a wrinkle reduction, a scar reduction, a burn treatment, a skin tightening, a vein reduction, a treatment on a sweat gland, a treatment of hyperhidrosis, a sun spot removal, a fat treatment, a cellulite treatment, a décolletage treatment, a vaginal rejuvenation, and an acne treatment. The ultrasound treatment system may include the ultrasonic transducer is configured to provide an acoustic power of the ultrasonic therapy in a range of between 10W to 100W and a frequency of 1 MHz to 12 MHz to thermally heat the tissue to cause coagulation.

[0203] In several embodiments, an treatment system for creating multiple focal points simultaneously at different depths with an ultrasound transducer is provided, the system comprising an ultrasonic probe comprising: a first switch operably controlling an ultrasonic imaging function for providing an ultrasonic imaging; a second switch operably controlling an ultrasonic treatment function for providing an ultrasonic treatment; and a movement mechanism configured to direct ultrasonic treatment in at least one sequence of

individual thermal cosmetic treatment zones; and a transducer module configured to apply ultrasonic therapy with at least one of the group consisting of amplitude modulation, phase shifting, and phase shifting, wherein the transducer module is configured for both ultrasonic imaging and ultrasonic treatment, wherein the transducer module is configured for coupling to the ultrasonic probe, wherein the transducer module comprises an ultrasound transducer configured to apply ultrasonic therapy to tissue at a plurality of locations with at least two focal depths, wherein the transducer module is configured to be operably coupled to at least one of the first switch, the second switch and the movement mechanism; and a control module, wherein the control module comprises a processor and a display for controlling the transducer module. In one embodiment, the ultrasonic treatment is a cosmetic treatment, wherein the plurality of locations are positioned in a substantially linear sequence within a cosmetic treatment zone. The treatment system may include an ultrasonic treatment that is an aesthetic treatment, wherein a first set of locations is positioned within a first treatment zone and a second set of locations is positioned within a second treatment zone, the first zone being different from the second zone. In one embodiment, the first treatment zone comprises a substantially linear sequence of the first set of locations and the second treatment zone comprises a substantially linear sequence of the second set of locations. The transducer module may be configured to apply ultrasonic therapy using amplitude modulation whereby a plurality of portions of the transducer module are configured to emit ultrasonic therapy at a plurality of amplitudes of acoustic intensity, wherein a first amplitude is different than a second amplitude. In one embodiment, the transducer module is configured to apply ultrasonic therapy phase shifting whereby a plurality of portions of the transducer module are configured to emit ultrasonic therapy at a plurality of phases of acoustic intensity, wherein a first phase is different than a second phase. The transducer module may be configured to: apply ultrasonic therapy using amplitude modulation whereby a plurality of portions of the transducer module are configured to emit ultrasonic therapy at a plurality of amplitudes of acoustic intensity, wherein a first amplitude is different than a second amplitude; and apply ultrasonic therapy phase shifting whereby a plurality of portions of the transducer module are configured to emit ultrasonic therapy at a plurality of phases of acoustic intensity, wherein a first phase is different than a second phase. In one embodiment, the plurality of phases

comprises discrete phase values. The transducer module may comprise a piezoelectric material and the plurality of portions of the transducer module are configured to create a plurality of corresponding piezoelectric material variations in response to an electric field applied to the transducer module. In one embodiment, the plurality of piezoelectric material variations comprise at least one of expansion of the material and contraction of the material. The treatment system may include at least one portion of the transducer module is configured to emit ultrasonic therapy at two or more amplitudes of acoustic intensity, and wherein the amplitude of ultrasonic therapy emitted by the at least one portion of the transducer module varies over time. In one embodiment, the movement mechanism is configured to be programmed to provide variable spacing between a plurality of individual thermal cosmetic treatment zones. The treatment system may include a sequence of individual thermal cosmetic treatment zones has a treatment spacing in a range from 1 mm to 25 mm. In one embodiment, the first and second switches comprises user operated buttons or keys. The treatment system may include at least one of the first switch and the second switch is activated by the control module. In one embodiment, the treatment function is at least one of a face lift, a brow lift, a chin lift, an eye treatment, a wrinkle reduction, a scar reduction, a burn treatment, a tattoo removal, a skin tightening, a vein removal, a vein reduction, a treatment on a sweat gland, a treatment of hyperhidrosis, a sun spot removal, a fat treatment, a cellulite treatment, a décolletage treatment, a vaginal rejuvenation, and an acne treatment. The transducer module may be configured to provide an acoustic power of the ultrasonic therapy in a range of between 10 W to 1000W and a frequency of 1 MHz to 20 MHz to thermally heat the tissue to cause coagulation.

[0204] In several embodiments, a treatment system for delivering simultaneous treatment at multiple depths, the system comprising: a controlling device operably controlling an ultrasonic treatment function for providing an ultrasonic treatment; and a hand wand configured to direct ultrasonic treatment in a sequence of individual thermal cosmetic treatment zones, the hand wand comprising: a transducer configured to apply ultrasonic therapy to tissue at a location at a focal depth, the location positioned within a thermal cosmetic treatment zone, wherein the transducer is further configured to simultaneously apply ultrasonic therapy to tissue at a plurality of locations at the focal depth.

[0205] In several embodiments, a method of performing a noninvasive cosmetic procedure on the skin by creating multiple simultaneous focal points at multiple depths with a single transducer, the method comprising: coupling a transducer module with an ultrasonic probe; wherein the ultrasonic probe comprises a first switch to control acoustic imaging; wherein the ultrasonic probe comprises a second switch to control acoustic therapy for causing a plurality of individual cosmetic treatment zones; wherein the ultrasonic probe comprises a movement mechanism to provide desired spacing between the individual cosmetic treatment zones; contacting the transducer module with a subject's skin surface; activating the first switch on the ultrasonic probe to acoustically image, with the transducer module, a region below the skin surface; and activating the second switch on the ultrasonic probe to acoustically treat, with the transducer module, the region below the skin surface in a desired sequence of individual cosmetic treatment zones that is controlled by the movement mechanism, wherein the transducer module comprises a single ultrasound transducer configured to apply ultrasonic therapy to tissue at a plurality of focal depths.

[0206] In several embodiments, an ultrasound treatment system for creating multiple focal points simultaneously at multiple depths in tissue with an ultrasound transducer, the system comprising: a controlling device operably controlling an ultrasonic treatment function for providing an ultrasonic treatment; and a hand wand configured to direct ultrasonic treatment in a sequence of individual thermal cosmetic treatment zones, the hand wand comprising: a transducer configured to apply ultrasonic therapy to tissue at a plurality of locations at a focal depth. In one embodiment, the non-invasive cosmetic treatment of skin.

[0207] In several embodiments, an imaging and treatment system for use in cosmetic treatment at multiple depths in tissue, the system comprising: an ultrasonic probe configured for ultrasonic imaging and ultrasonic treatment of tissue at a plurality of focal depths, comprising: a transducer module configured for coupling to the ultrasonic probe, wherein the transducer module comprises an ultrasound transducer configured to apply an ultrasonic therapy to tissue at the plurality of locations at the focal depth, a first switch operably controlling an ultrasonic imaging function for providing an ultrasonic imaging; a second switch operably controlling an ultrasonic treatment function for providing the

ultrasonic therapy; and a movement mechanism configured to direct ultrasonic treatment in at least one sequence of individual thermal cosmetic treatment zones; and wherein the transducer module is configured to be operably coupled to at least one of the first switch, the second switch and the movement mechanism; and a control module, wherein the control module comprises a processor and a display for controlling the transducer module. In one embodiment, the plurality of locations are positioned in a substantially linear sequence within a cosmetic treatment zone. The imaging and treatment system may include a first set of locations is positioned within a first cosmetic treatment zone and a second set of locations is positioned within a second cosmetic treatment zone, the first zone being different from the second zone. In one embodiment, the first cosmetic treatment zone comprises a substantially linear sequence of the first set of locations and the second cosmetic treatment zone comprises a substantially linear sequence of the second set of locations. The transducer module may be configured to apply ultrasonic therapy using amplitude modulation whereby a plurality of portions of the transducer module are configured to emit ultrasonic therapy at a plurality of amplitudes of acoustic intensity, wherein a first amplitude is different than a second amplitude. In one embodiment, the transducer module is configured to apply ultrasonic therapy phase shifting whereby a plurality of portions of the transducer module are configured to emit ultrasonic therapy at a plurality of phases of acoustic intensity, wherein a first phase is different than a second phase. The transducer module may be configured to: apply ultrasonic therapy using amplitude modulation whereby a plurality of portions of the transducer module are configured to emit ultrasonic therapy at a plurality of amplitudes of acoustic intensity, wherein a first amplitude is different than a second amplitude; and apply ultrasonic therapy phase shifting whereby a plurality of portions of the transducer module are configured to emit ultrasonic therapy at a plurality of phases of acoustic intensity, wherein a first phase is different than a second phase. In one embodiment, the plurality of phases comprises discrete phase values. The transducer module may comprise piezoelectric material and the plurality of portions of the transducer module are configured to create a plurality of corresponding piezoelectric material variations in response to an electric field applied to the transducer module. In one embodiment, the plurality of piezoelectric material variations comprise at least one of expansion of the material and contraction of the material. At least

one portion of the transducer module may be configured to emit ultrasonic therapy at two or more amplitudes of acoustic intensity, and wherein the amplitude of ultrasonic therapy emitted by the at least one portion of the transducer module varies over time. In one embodiment, the movement mechanism is configured to be programmed to provide variable spacing between a plurality of individual thermal cosmetic treatment zones. A sequence of individual thermal cosmetic treatment zones may have a treatment spacing in a range from 0.01 mm to 25 mm. In one embodiment, the first and second switches comprises user operated buttons or keys. At least one of the first switch and the second switch may be activated by the control module. In one embodiment, the treatment function is at least one of a face lift, a brow lift, a chin lift, an eye treatment, a wrinkle reduction, a scar reduction, a burn treatment, a tattoo removal, a skin tightening, a vein removal, a vein reduction, a treatment on a sweat gland, a treatment of hyperhidrosis, a sun spot removal, a fat treatment, a vaginal rejuvenation, and an acne treatment. The transducer module may be configured to provide an acoustic power of the ultrasonic therapy in a range of between 10W to 1000W and a frequency of 1 MHz to 10 MHz to thermally heat the tissue to cause coagulation.

[0208] In several embodiments, a multi-focus ultrasound treatment system for simultaneous treatment at multiple depths, the system comprising: a controlling device operably controlling an ultrasonic treatment function for providing an ultrasonic treatment; and a hand wand configured to direct ultrasonic treatment in a sequence of individual thermal cosmetic treatment zones, the hand wand comprising: a transducer configured to apply ultrasonic therapy to tissue at a location at a focal depth, the location positioned within a thermal cosmetic treatment zone, wherein the transducer is further configured to apply ultrasonic therapy to tissue simultaneously at a plurality of locations at the focal depth.

[0209] In several embodiments, an imaging and simultaneous multi-focus treatment system at multiple depths comprising: a module comprising an ultrasound transducer, wherein the ultrasound transducer is configured to apply ultrasonic therapy to tissue at a plurality of focal depths with at least one of the group consisting of amplitude modulation, phase shifting, and phase shifting, wherein the module further comprises an interface guide designed to for removable coupling to a hand wand to provide electronic communication and power between the module and the hand wand. In one embodiment, the

plurality of locations are positioned in a substantially linear sequence within a cosmetic treatment zone. A first set of locations may be positioned within a first cosmetic treatment zone and a second set of locations is positioned within a second cosmetic treatment zone, the first zone being different from the second zone. In one embodiment, the first cosmetic treatment zone comprises a substantially linear sequence of the first set of locations and the second cosmetic treatment zone comprises a substantially linear sequence of the second set of locations. The ultrasound transducer may be configured to apply ultrasonic therapy using amplitude modulation whereby a plurality of portions of the ultrasound transducer are configured to emit ultrasonic therapy at a plurality of amplitudes of acoustic intensity, wherein a first amplitude is different than a second amplitude. In one embodiment, the ultrasound transducer is configured to apply ultrasonic therapy phase shifting whereby a plurality of portions of the ultrasound transducer are configured to emit ultrasonic therapy at a plurality of phases of acoustic intensity, wherein a first phase is different than a second phase. The ultrasound transducer may be configured to: apply ultrasonic therapy using amplitude modulation whereby a plurality of portions of the ultrasound transducer are configured to emit ultrasonic therapy at a plurality of amplitudes of acoustic intensity, wherein a first amplitude is different than a second amplitude; and apply ultrasonic therapy phase shifting whereby a plurality of portions of the ultrasound transducer are configured to emit ultrasonic therapy at a plurality of phases of acoustic intensity, wherein a first phase is different than a second phase. In one embodiment, the plurality of phases comprises discrete phase values. The ultrasound transducer may comprise piezoelectric material and the plurality of portions of the ultrasound transducer are configured to create a plurality of corresponding piezoelectric material variations in response to an electric field applied to the ultrasound transducer. In one embodiment, the plurality of piezoelectric material variations comprise at least one of expansion of the piezoelectric material and contraction of the piezoelectric material. At least one portion of the ultrasonic transducer may be configured to emit ultrasonic therapy at two or more amplitudes of acoustic intensity, and wherein the amplitude of ultrasonic therapy emitted by the at least one portion of the piezoelectric varies over time. In one embodiment, the imaging and treatment system further comprising a movement mechanism configured to be programmed to provide spacing between the plurality

of individual cosmetic treatment zones. The sequence of individual cosmetic treatment zones may have a treatment spacing in a range from 1 mm to 50 mm. In one embodiment, the ultrasonic treatment is at least one of a face lift, a brow lift, a chin lift, an eye treatment, a wrinkle reduction, a scar reduction, a burn treatment, a tattoo removal, a skin tightening, a vein removal, a vein reduction, a treatment on a sweat gland, a treatment of hyperhidrosis, a sun spot removal, a fat treatment, a vaginal rejuvenation, and an acne treatment. The ultrasonic transducer may be configured to provide an acoustic power of the ultrasonic therapy in a range of between 1W to 100W and a frequency of 1 MHz to 10 MHz to thermally heat the tissue to cause coagulation.

[0210] In several embodiments, a treatment system for simultaneous treatment at multiple depths, the system comprising: a controlling device operably controlling an ultrasonic treatment function for providing an ultrasonic treatment; and a hand wand configured to direct ultrasonic treatment in a sequence of individual thermal cosmetic treatment zones, the hand wand comprising: a transducer configured to simultaneously apply ultrasonic therapy to tissue at a plurality of locations at a focal depth.

[0211] In several embodiments, a non-invasive method of simultaneously performing a cosmetic procedure at multiple depths that is not performed by a doctor, the method comprising: coupling a transducer module with an ultrasonic probe; wherein the transducer module comprises an ultrasound transducer configured to apply ultrasonic therapy to tissue at a plurality of locations at a focal depth with at least one of the group consisting of amplitude modulation, poling and phase shifting, wherein the ultrasonic probe comprises a first switch to control acoustic imaging; wherein the ultrasonic probe comprises a second switch to control acoustic therapy for causing a plurality of individual cosmetic treatment zones; wherein the ultrasonic probe comprises a movement mechanism to provide desired spacing between the individual cosmetic treatment zones; contacting the transducer module with a subject's skin surface; activating the first switch on the ultrasonic probe to acoustically image, with the transducer module, a region below the skin surface; and activating the second switch on the ultrasonic probe to acoustically treat, with the transducer module, the region below the skin surface in a desired sequence of individual cosmetic treatment zones that is controlled by the movement mechanism.

[0212] In several embodiments, an imaging and treatment system according is used for the non-invasive cosmetic treatment of skin.

[0213] In several embodiments, an ultrasound treatment system for dithering multiple simultaneous focus points from an ultrasound transducer at multiple depths, comprises: an ultrasonic probe comprising an ultrasound transducer with a single transduction element adapted to simultaneously apply ultrasonic therapy to tissue at a plurality of spaced focal depths, wherein the ultrasound transducer is poled with at least a first poling configuration and a second poling configuration, a control module coupled to the ultrasonic probe for controlling the ultrasound transducer, wherein the control module modifies the spacing between the spaced locations via dithering of a first focal zone and a second focal zone, such that dithering via modulation of a frequency precisely moves a position of a beam focus point at the spaced locations. The plurality of locations may be positioned in a linear sequence within a cosmetic treatment zone, wherein the spaced locations are separated with a spacing dithered via a frequency swing. In one embodiment, a first set of locations is positioned within a first cosmetic treatment zone and a second set of locations is positioned within a second cosmetic treatment zone, the first zone being different from the second zone. The ultrasound transducer may be adapted to apply ultrasonic therapy using amplitude modulation whereby a plurality of portions of the ultrasound transducer are adapted to emit ultrasonic therapy at a plurality of amplitudes of acoustic intensity, wherein a first amplitude is different than a second amplitude. In one embodiment, at least one portion of the ultrasonic transducer is adapted to emit ultrasonic therapy at two or more amplitudes of acoustic intensity, and wherein the amplitude of ultrasonic therapy emitted by the at least one portion of the piezoelectric varies over time. The ultrasound transducer may comprise piezoelectric material and the plurality of portions of the ultrasound transducer are adapted to create a plurality of corresponding piezoelectric material variations in response to an electric field applied to the ultrasound transducer. In one embodiment, the plurality of piezoelectric material variations comprise at least one of expansion of the piezoelectric material and contraction of the piezoelectric material. The ultrasound transducer may be adapted to apply ultrasonic therapy via phase shifting whereby a plurality of portions of the ultrasound transducer are adapted to emit ultrasonic therapy at a plurality of phases of acoustic intensity,

wherein a first phase is different than a second phase. In one embodiment, the plurality of phases comprises discrete phase values. The ultrasound transducer may be adapted to: apply ultrasonic therapy using amplitude modulation whereby a plurality of portions of the ultrasound transducer are adapted to emit ultrasonic therapy at a plurality of amplitudes of acoustic intensity, wherein a first amplitude is different than a second amplitude; and apply ultrasonic therapy whereby a plurality of portions of the ultrasound transducer are adapted to emit ultrasonic therapy at a plurality of phases of acoustic intensity, wherein a first phase is different than a second phase. In one embodiment, the ultrasonic treatment is at least one of: a face lift, a brow lift, a chin lift, an eye treatment, a wrinkle reduction, a décolletage improvement, a buttock lift, a scar reduction, a burn treatment, a skin tightening, a blood vessel reduction, a treatment of a sweat gland, a sun spot removal, a fat treatment, an abdominal laxity treatment, and a cellulite treatment. The ultrasonic probe may comprise a movement mechanism adapted to direct ultrasonic treatment in at least one pair of simultaneous sequences of individual thermal cosmetic treatment zones. In one embodiment, the ultrasonic probe is configured for both ultrasonic imaging and ultrasonic treatment. The ultrasonic probe may comprise a transducer module adapted to apply ultrasonic therapy.

[0214] In several embodiments, an ultrasound treatment system for use in cosmetic treatment for dithering multiple simultaneous focal points at multiple depths from an ultrasound transducer, the system comprising: an ultrasonic probe comprising: a control module adapted to modify a spacing between a first focal zone and a second focal zone via dithering, a switch operably controlling an ultrasonic treatment function for providing an ultrasonic treatment; and a movement mechanism adapted to direct ultrasonic treatment in at least one pair of simultaneous sequences of individual thermal cosmetic treatment zones; and a transducer module adapted to apply ultrasonic therapy, wherein the transducer module is adapted for both ultrasonic imaging and ultrasonic treatment, wherein the transducer module is adapted for coupling to the ultrasonic probe, wherein the transducer module comprises an ultrasound transducer adapted to apply ultrasonic therapy to tissue at a plurality of locations with at least two focal depths, wherein the transducer module is adapted to be operably coupled to at least one of the switch and the movement mechanism; and wherein the control module comprises a processor and a display for controlling the transducer module. In one

embodiment, the transducer module is adapted to apply ultrasonic therapy using amplitude modulation whereby a plurality of portions of the transducer module are adapted to emit ultrasonic therapy at a plurality of amplitudes of acoustic intensity, wherein a first amplitude is different than a second amplitude. The transducer module may be adapted to apply ultrasonic therapy whereby a plurality of portions of the transducer module are adapted to emit ultrasonic therapy at a plurality of phases of acoustic intensity, wherein a first phase is different than a second phase.

[0215] In several embodiments, an ultrasound treatment system for dithering simultaneous multi-focus treatment at a plurality of depths, comprising: a module comprising an ultrasound transducer, wherein the ultrasound transducer is adapted to simultaneously apply ultrasonic therapy to tissue at a plurality of spaced depths in tissue, wherein the module modifies a spacing between the plurality of spaced depths via dithering of a first focal zone and a second focal zone, such that dithering via modulation of a frequency precisely moves a position of a beam focus point at the plurality of spaced depths, wherein the module further comprises an interface guide designed to for removable coupling to a hand wand to provide electronic communication and power between the module and the hand wand. In one embodiment, the ultrasound transducer is adapted to apply ultrasonic therapy using amplitude modulation whereby a plurality of portions of the ultrasound transducer are adapted to emit ultrasonic therapy at a plurality of amplitudes of acoustic intensity, wherein a first amplitude is different than a second amplitude. The ultrasound transducer may be adapted to apply ultrasonic therapy whereby a plurality of portions of the ultrasound transducer are adapted to emit ultrasonic therapy at a plurality of phases of acoustic intensity, wherein a first phase is different than a second phase. In one embodiment, the ultrasound transducer comprises piezoelectric material and the plurality of portions of the ultrasound transducer are adapted to create a plurality of corresponding piezoelectric material variations in response to an electric field applied to the ultrasound transducer. At least one portion of the ultrasonic transducer may be adapted to emit ultrasonic therapy at two or more amplitudes of acoustic intensity, and wherein the amplitude of ultrasonic therapy emitted by the at least one portion of the ultrasonic transducer remains constant over time. In one embodiment, the ultrasonic treatment is at least one of a face lift, a brow lift, a chin lift, an eye treatment, a wrinkle

reduction, a décolletage improvement, a buttock lift, a scar reduction, a burn treatment, a tattoo removal, a skin tightening, a vein removal, a vein reduction, a treatment on a sweat gland, a treatment of hyperhidrosis, a sun spot removal, a fat treatment, a cellulite treatment, an abdominal laxity treatment, a vaginal rejuvenation, and an acne treatment.

[0216] In several embodiments, a method of dithering simultaneous focused ultrasound treatment beams at a plurality of depths, comprising: providing an ultrasonic probe comprising an ultrasound transducer comprising a single transduction element adapted to simultaneously apply ultrasonic therapy to tissue at a plurality of spaced locations at a plurality of focal depths and a control module coupled to the ultrasonic probe for controlling the ultrasound transducer, and dithering the spacing between the spaced locations of a first focal zone and a second focal zone via modulation of a frequency to move a position of an ultrasound focus point at the spaced locations. In one embodiment, the method comprises imaging the first focal zone with an ultrasound imaging element. The method may further comprise imaging the second focal zone with an ultrasound imaging element. In one embodiment, the spacing between the first focal zone and the second focal zone is dithered in a range of between 1 – 50%. The spacing between the first focal zone and the second focal zone may be 1.5 mm and is by 0.1 mm. In one embodiment, the modulation of frequency is in a range of between 1 – 50%. The ultrasound treatment may be at least one of a face lift, a brow lift, a chin lift, an eye treatment, a wrinkle reduction, a décolletage improvement, a buttock lift, a scar reduction, a burn treatment, a tattoo removal, a skin tightening, a vein removal, a vein reduction, a treatment on a sweat gland, a treatment of hyperhidrosis, a sun spot removal, a fat treatment, a vaginal rejuvenation, a treatment for abdominal laxity, and an acne treatment.

[0217] In several embodiments, a method of simultaneously dithering a focused ultrasound beam at multiple depths, comprising: providing an ultrasonic probe comprising a single transduction element and a control module, wherein the single transduction element is adapted to apply ultrasonic therapy to tissue at a focal zone at a focal depth, wherein the control module is coupled to the ultrasonic probe for controlling the single transduction element, and dithering the focal zone via modulation of a frequency to alter a size of the focal zone at the tissue. In one embodiment, the relative position of the focal zone is dithered in a

range of between 1 – 50%. The second focal zone may be emitted simultaneously from the single transduction element. In one embodiment, the modulation of the frequency is in a range of between 1 – 50%. The system may be designed to work non-invasively to treat tissue. In one embodiment, the method functions in a non-invasive manner to treat tissue.

[0218] In several embodiments, an ultrasound treatment system for delivering simultaneous multi-focus treatment at a plurality of depths with an electrostrictor, comprising: a module comprising an ultrasound transducer, wherein the ultrasound transducer is adapted to simultaneously apply ultrasonic therapy to tissue at a plurality of spaced depths in tissue with the application of an electrostrictor, wherein the module modifies a spacing between the plurality of spaced depths via dithering of a first focal zone and a second focal zone, such that dithering via modulation of a frequency precisely moves a position of a beam focus point at the plurality of spaced depths, wherein the module further comprises an interface guide designed to for removable coupling to a hand wand to provide electronic communication and power between the module and the hand wand. In one embodiment, the ultrasound transducer is adapted to apply ultrasonic therapy using amplitude modulation whereby a plurality of portions of the ultrasound transducer are adapted to emit ultrasonic therapy at a plurality of amplitudes of acoustic intensity, wherein a first amplitude is different than a second amplitude. The ultrasound transducer may be adapted to apply ultrasonic therapy whereby a plurality of portions of the ultrasound transducer are adapted to emit ultrasonic therapy at a plurality of phases of acoustic intensity, wherein a first phase is different than a second phase. In one embodiment, the ultrasound transducer comprises piezoelectric material and the plurality of portions of the ultrasound transducer are adapted to create a plurality of corresponding piezoelectric material variations in response to an electric field applied to the ultrasound transducer. At least one portion of the ultrasonic transducer may be adapted to emit ultrasonic therapy at two or more amplitudes of acoustic intensity, and wherein the amplitude of ultrasonic therapy emitted by the at least one portion of the ultrasonic transducer remains constant over time. In one embodiment, the ultrasonic treatment is at least one of a face lift, a brow lift, a chin lift, an eye treatment, a wrinkle reduction, a décolletage improvement, a buttock lift, a scar reduction, a burn treatment, a tattoo removal, a skin tightening, a vein removal, a vein reduction, a treatment on a sweat

gland, a treatment of hyperhidrosis, a sun spot removal, a fat treatment, a cellulite treatment, an abdominal laxity treatment, a vaginal rejuvenation, and an acne treatment.

[0219] In several embodiments, an ultrasound treatment system having one or more of the features described in the foregoing description.

[0220] In several embodiments, a method of reducing imaging misalignment in a moving ultrasound transducer having one or more of the features described in the foregoing description.

[0221] In several embodiments, an ultrasound treatment system for producing multiple simultaneous focus points from an ultrasound transducer having one or more of the features described in the foregoing description.

[0222] In several embodiments, an ultrasound treatment system for delivering multi-focus treatment having one or more of the features described in the foregoing description.

[0223] In several embodiments, an ultrasound treatment module for use in cosmetic treatment for forming multiple simultaneous focal zones from an ultrasound transducer having one or more of the features described in the foregoing description.

[0224] In several embodiments, a method of generating simultaneous focused ultrasound treatment beams using multi-channel signal mixing having one or more of the features described in the foregoing description.

[0225] In several embodiments, a method of generating simultaneous focused ultrasound beams having one or more of the features described in the foregoing description.

[0226] Some embodiments and the examples described herein are examples and not intended to be limiting in describing the full scope of compositions and methods of these invention. Equivalent changes, modifications and variations of some embodiments, materials, compositions and methods can be made within the scope of the present invention, with substantially similar results.

[0227] While the invention is susceptible to various modifications, and alternative forms, specific examples thereof have been shown in the drawings and are herein described in detail. It should be understood, however, that the invention is not to be limited to the particular forms or methods disclosed, but to the contrary, the invention is to cover all

modifications, equivalents, and alternatives falling within the spirit and scope of the various embodiments described and the appended claims. Any methods disclosed herein need not be performed in the order recited. The methods disclosed herein include certain actions taken by a practitioner; however, they can also include any third-party instruction of those actions, either expressly or by implication. For example, actions such as “coupling a transducer module with an ultrasonic probe” include “instructing the coupling of a transducer module with an ultrasonic probe.” The ranges disclosed herein also encompass any and all overlap, sub-ranges, and combinations thereof. Language such as “up to,” “at least,” “greater than,” “less than,” “between,” and the like includes the number recited. Numbers preceded by a term such as “about” or “approximately” include the recited numbers. For example, “about 25 mm” includes “25 mm.”

What is claimed is:

1. An treatment system for creating multiple focal points simultaneously at different depths with an ultrasound transducer, the system comprising:

an ultrasonic probe comprising:

a first switch operably controlling an ultrasonic imaging function for providing an ultrasonic imaging;

a second switch operably controlling an ultrasonic treatment function for providing an ultrasonic treatment; and

a movement mechanism configured to direct ultrasonic treatment in at least one sequence of individual thermal cosmetic treatment zones; and

a transducer module configured to apply ultrasonic therapy with at least one of the group consisting of amplitude modulation poling and phase shifting,

wherein the transducer module is configured for both ultrasonic imaging and ultrasonic treatment,

wherein the transducer module is configured for coupling to the ultrasonic probe,

wherein the transducer module comprises an ultrasound transducer configured to apply ultrasonic therapy to tissue at a plurality of locations with at least two focal depths,

wherein the transducer module is configured to be operably coupled to at least one of the first switch, the second switch and the movement mechanism; and

a control module,

wherein the control module comprises a processor and a display for controlling the transducer module.

2. The treatment system of Claim 1, wherein the ultrasonic treatment is a cosmetic treatment, wherein the plurality of locations are positioned in a substantially linear sequence within a cosmetic treatment zone.

3. The treatment system of Claim 1, wherein the ultrasonic treatment is an aesthetic treatment, wherein a first set of locations is positioned within a first treatment zone and a second set of locations is positioned within a second treatment zone, the first zone being different from the second zone.

4. The treatment system of Claim 3, wherein the first treatment zone comprises a substantially linear sequence of the first set of locations and the second treatment zone comprises a substantially linear sequence of the second set of locations.

5. The treatment system of any one of Claims 1-4, wherein the transducer module is configured to apply ultrasonic therapy using amplitude modulation whereby a plurality of portions of the transducer module are configured to emit ultrasonic therapy at a plurality of amplitudes of acoustic intensity, wherein a first amplitude is different than a second amplitude.

6. The treatment system of any one of Claims 1-4, wherein the transducer module is configured to apply ultrasonic therapy phase shifting whereby a plurality of portions of the transducer module are configured to emit ultrasonic therapy at a plurality of phases of acoustic intensity, wherein a first phase is different than a second phase.

7. The treatment system of any one of Claims 1-4, wherein the transducer module is configured to:

apply ultrasonic therapy using amplitude modulation whereby a plurality of portions of the transducer module are configured to emit ultrasonic therapy at a plurality of amplitudes of acoustic intensity, wherein a first amplitude is different than a second amplitude; and

apply ultrasonic therapy phase shifting whereby a plurality of portions of the transducer module are configured to emit ultrasonic therapy at a plurality of phases of acoustic intensity, wherein a first phase is different than a second phase.

8. The treatment system of any one of Claims 1-4, wherein the plurality of phases comprises discrete phase values.

9. The treatment system of any one of Claims 1-4, wherein the transducer module comprises piezoelectric material and the plurality of portions of the transducer module are

configured to create a plurality of corresponding piezoelectric material variations in response to an electric field applied to the transducer module.

10. The treatment system of Claim 9, wherein the plurality of piezoelectric material variations comprise at least one of expansion of the material and contraction of the material.

11. The treatment system of any one of Claims 1-4, wherein at least one portion of the transducer module is configured to emit ultrasonic therapy at two or more amplitudes of acoustic intensity, and wherein the amplitude of ultrasonic therapy emitted by the at least one portion of the transducer module varies over time.

12. The treatment system of any one of Claims 1-4, wherein the movement mechanism is configured to be programmed to provide variable spacing between a plurality of individual thermal cosmetic treatment zones.

13. The treatment system according to any one of Claims 1-4, wherein a sequence of individual thermal cosmetic treatment zones has a treatment spacing in a range from 1 mm to 25 mm.

14. The treatment system according to any one of Claims 1-4, wherein the first and second switches comprises user operated buttons or keys.

15. The treatment system according to any one of Claims 1-4, wherein at least one of the first switch and the second switch is activated by the control module.

16. The treatment system according to any one of Claims 1-4, wherein the treatment function is at least one of a face lift, a brow lift, a chin lift, an eye treatment, a wrinkle reduction, a scar reduction, a burn treatment, a tattoo removal, a skin tightening, a vein removal, a vein reduction, a treatment on a sweat gland, a treatment of hyperhidrosis, a sun spot removal, a fat treatment, a cellulite treatment, a décolletage treatment, a vaginal rejuvenation, and an acne treatment.

17. The treatment system of any one of Claims 1-4, wherein the transducer module is configured to provide an acoustic power of the ultrasonic therapy in a range of between 10 W to 1000W and a frequency of 1 MHz to 20 MHz to thermally heat the tissue to cause coagulation.

18. An ultrasound treatment system for dithering multiple simultaneous focus points from an ultrasound transducer at multiple depths, comprising:

an ultrasonic probe comprising an ultrasound transducer with a single transduction element adapted to simultaneously apply ultrasonic therapy to tissue at a plurality of spaced focal depths,

wherein the ultrasound transducer is poled with at least a first poling configuration and a second poling configuration,

a control module coupled to the ultrasonic probe for controlling the ultrasound transducer,

wherein the control module modifies the spacing between the spaced locations via dithering of a first focal zone and a second focal zone, such that dithering via modulation of a frequency precisely moves a position of a beam focus point at the spaced locations.

19. The treatment system of Claim 18, wherein the plurality of locations are positioned in a linear sequence within a cosmetic treatment zone, wherein the spaced locations are separated with a spacing dithered via a frequency swing.

20. The treatment system of Claim 18, wherein a first set of locations is positioned within a first cosmetic treatment zone and a second set of locations is positioned within a second cosmetic treatment zone, the first zone being different from the second zone.

21. The treatment system of Claim 18, wherein the ultrasound transducer is adapted to apply ultrasonic therapy using amplitude modulation whereby a plurality of portions of the ultrasound transducer are adapted to emit ultrasonic therapy at a plurality of amplitudes of acoustic intensity, wherein a first amplitude is different than a second amplitude.

22. The treatment system of Claim 21, wherein at least one portion of the ultrasonic transducer is adapted to emit ultrasonic therapy at two or more amplitudes of acoustic intensity, and wherein the amplitude of ultrasonic therapy emitted by the at least one portion of the piezoelectric varies over time.

23. The treatment system of Claim 21, wherein the ultrasound transducer comprises piezoelectric material and the plurality of portions of the ultrasound transducer are adapted to create a plurality of corresponding piezoelectric material variations in response to an electric field applied to the ultrasound transducer.

24. The treatment system of Claim 23, wherein the plurality of piezoelectric material variations comprise at least one of expansion of the piezoelectric material and contraction of the piezoelectric material.

25. The treatment system of any one of Claims 18 - 21, wherein the ultrasound transducer is adapted to apply ultrasonic therapy via phase shifting whereby a plurality of portions of the ultrasound transducer are adapted to emit ultrasonic therapy at a plurality of phases of acoustic intensity, wherein a first phase is different than a second phase.

26. The treatment system of Claim 25, wherein the plurality of phases comprises discrete phase values.

27. The treatment system of any one of Claims 18 - 21, wherein the ultrasound transducer is adapted to:

apply ultrasonic therapy using amplitude modulation whereby a plurality of portions of the ultrasound transducer are adapted to emit ultrasonic therapy at a plurality of amplitudes of acoustic intensity, wherein a first amplitude is different than a second amplitude; and

apply ultrasonic therapy whereby a plurality of portions of the ultrasound transducer are adapted to emit ultrasonic therapy at a plurality of phases of acoustic intensity, wherein a first phase is different than a second phase.

28. The treatment system of any one of Claims 18 - 21, wherein the ultrasonic treatment is at least one of: a face lift, a brow lift, a chin lift, an eye treatment, a wrinkle reduction, a décolletage improvement, a buttock lift, a scar reduction, a burn treatment, a skin tightening, a blood vessel reduction, a treatment of a sweat gland, a sun spot removal, a fat treatment, an abdominal laxity treatment, and a cellulite treatment.

29. The treatment system of any one of Claims 18 - 21, wherein the ultrasonic probe comprises a movement mechanism adapted to direct ultrasonic treatment in at least one pair of simultaneous sequences of individual thermal cosmetic treatment zones.

30. The treatment system of any one of Claims 18 - 21, wherein the ultrasonic probe is configured for both ultrasonic imaging and ultrasonic treatment.

31. The treatment system of any one of Claims 18 - 21, wherein the ultrasonic probe comprises a transducer module adapted to apply ultrasonic therapy.

32. A method of simultaneously dithering a focused ultrasound beam at multiple depths, comprising:

providing an ultrasonic probe comprising a single transduction element and a control module,

wherein the single transduction element is adapted to apply ultrasonic therapy to tissue at a focal zone at a focal depth,

wherein the control module is coupled to the ultrasonic probe for controlling the single transduction element, and

dithering the focal zone via modulation of a frequency to alter a size of the focal zone at the tissue.

33. The method of Claim 32, wherein the relative position of the focal zone is dithered in a range of between 1 – 50%.

34. The method of Claim 32, wherein a second focal zone is emitted simultaneously from the single transduction element.

35. The method of Claim 32, further comprising imaging the focal zone with an ultrasound imaging element.

36. The method of Claim 32, wherein the modulation of the frequency is in a range of between 1 – 50%.

37. The treatment system of Claim 32, wherein the system is designed to work non-invasively to treat tissue.

38. The method of any one of Claims 32 - 36, wherein the method functions in a non-invasive manner to treat tissue.

39. An ultrasound treatment system for delivering simultaneous multi-focus treatment at a plurality of depths with an electrostrictor, comprising:

a module comprising an ultrasound transducer,

wherein the ultrasound transducer is adapted to simultaneously apply ultrasonic therapy to tissue at a plurality of spaced depths in tissue with the application of an electrostrictor,

wherein the module modifies a spacing between the plurality of spaced depths via dithering of a first focal zone and a second focal zone, such that dithering via

modulation of a frequency precisely moves a position of a beam focus point at the plurality of spaced depths,

wherein the module further comprises an interface guide designed to for removable coupling to a hand wand to provide electronic communication and power between the module and the hand wand.

40. The treatment system of Claim 39, wherein the ultrasound transducer is adapted to apply ultrasonic therapy using amplitude modulation whereby a plurality of portions of the ultrasound transducer are adapted to emit ultrasonic therapy at a plurality of amplitudes of acoustic intensity, wherein a first amplitude is different than a second amplitude.

41. The treatment system of Claim 39, wherein the ultrasound transducer is adapted to apply ultrasonic therapy whereby a plurality of portions of the ultrasound transducer are adapted to emit ultrasonic therapy at a plurality of phases of acoustic intensity, wherein a first phase is different than a second phase.

42. The treatment system of Claim 39, wherein the ultrasound transducer comprises piezoelectric material and the plurality of portions of the ultrasound transducer are adapted to create a plurality of corresponding piezoelectric material variations in response to an electric field applied to the ultrasound transducer.

43. The treatment system of Claim 39, wherein at least one portion of the ultrasonic transducer is adapted to emit ultrasonic therapy at two or more amplitudes of acoustic intensity, and wherein the amplitude of ultrasonic therapy emitted by the at least one portion of the ultrasonic transducer remains constant over time.

44. The treatment system of any one of Claims 39- 43, wherein the ultrasonic treatment is at least one of a face lift, a brow lift, a chin lift, an eye treatment, a wrinkle reduction, a décolletage improvement, a buttock lift, a scar reduction, a burn treatment, a tattoo removal, a skin tightening, a vein removal, a vein reduction, a treatment on a sweat gland, a treatment of hyperhidrosis, a sun spot removal, a fat treatment, a cellulite treatment, an abdominal laxity treatment, a vaginal rejuvenation, and an acne treatment.

45. An ultrasound treatment system having one or more of the features described in the foregoing description.

46. A method of reducing imaging misalignment in a moving ultrasound transducer having one or more of the features described in the foregoing description.

47. An ultrasound treatment system for producing multiple simultaneous focus points from an ultrasound transducer having one or more of the features described in the foregoing description.

48. An ultrasound treatment system for delivering multi-focus treatment having one or more of the features described in the foregoing description.

49. An ultrasound treatment module for use in cosmetic treatment for forming multiple simultaneous focal zones from an ultrasound transducer having one or more of the features described in the foregoing description.

50. A method of generating simultaneous focused ultrasound treatment beams using multi-channel signal mixing having one or more of the features described in the foregoing description.

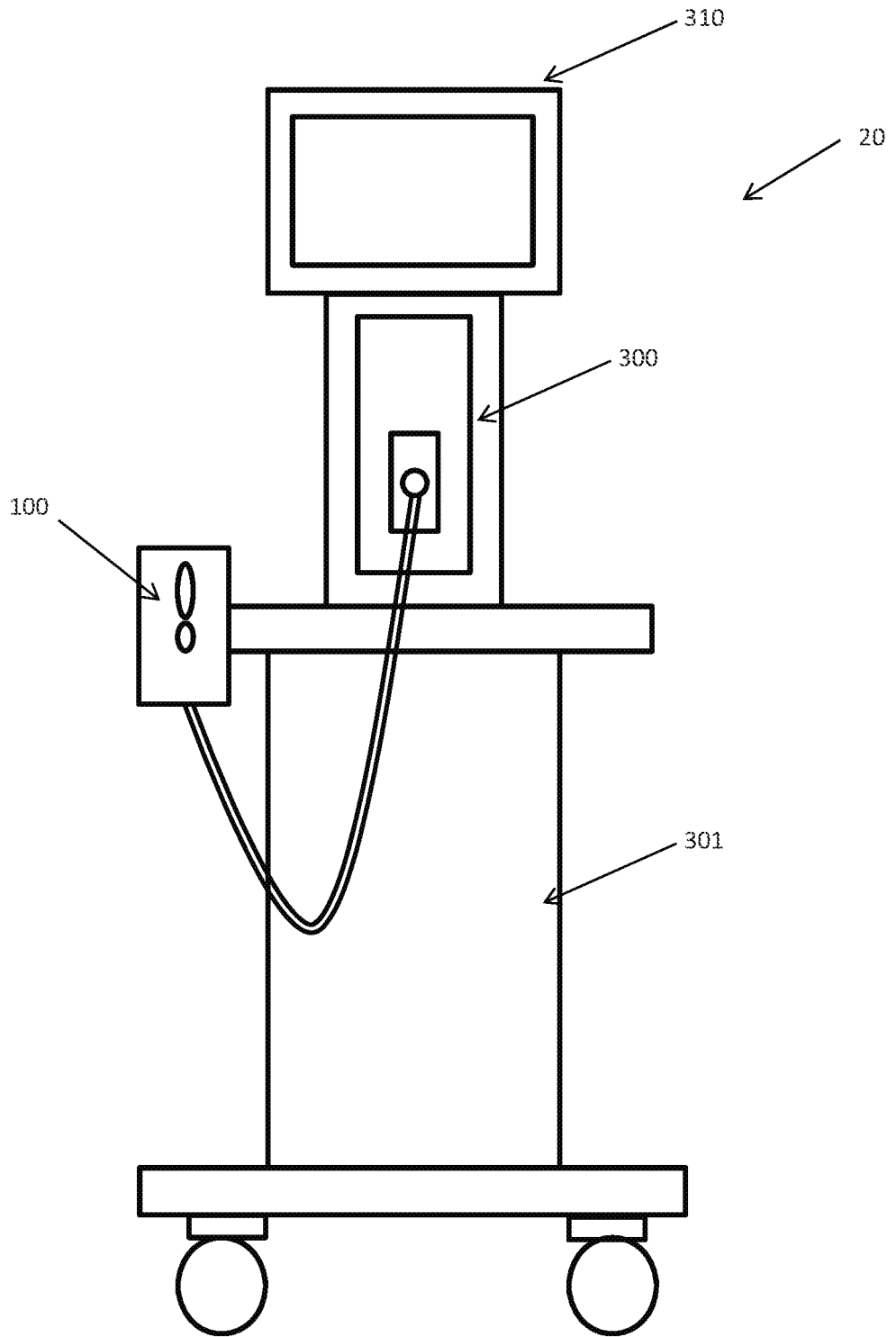

FIG. 1A

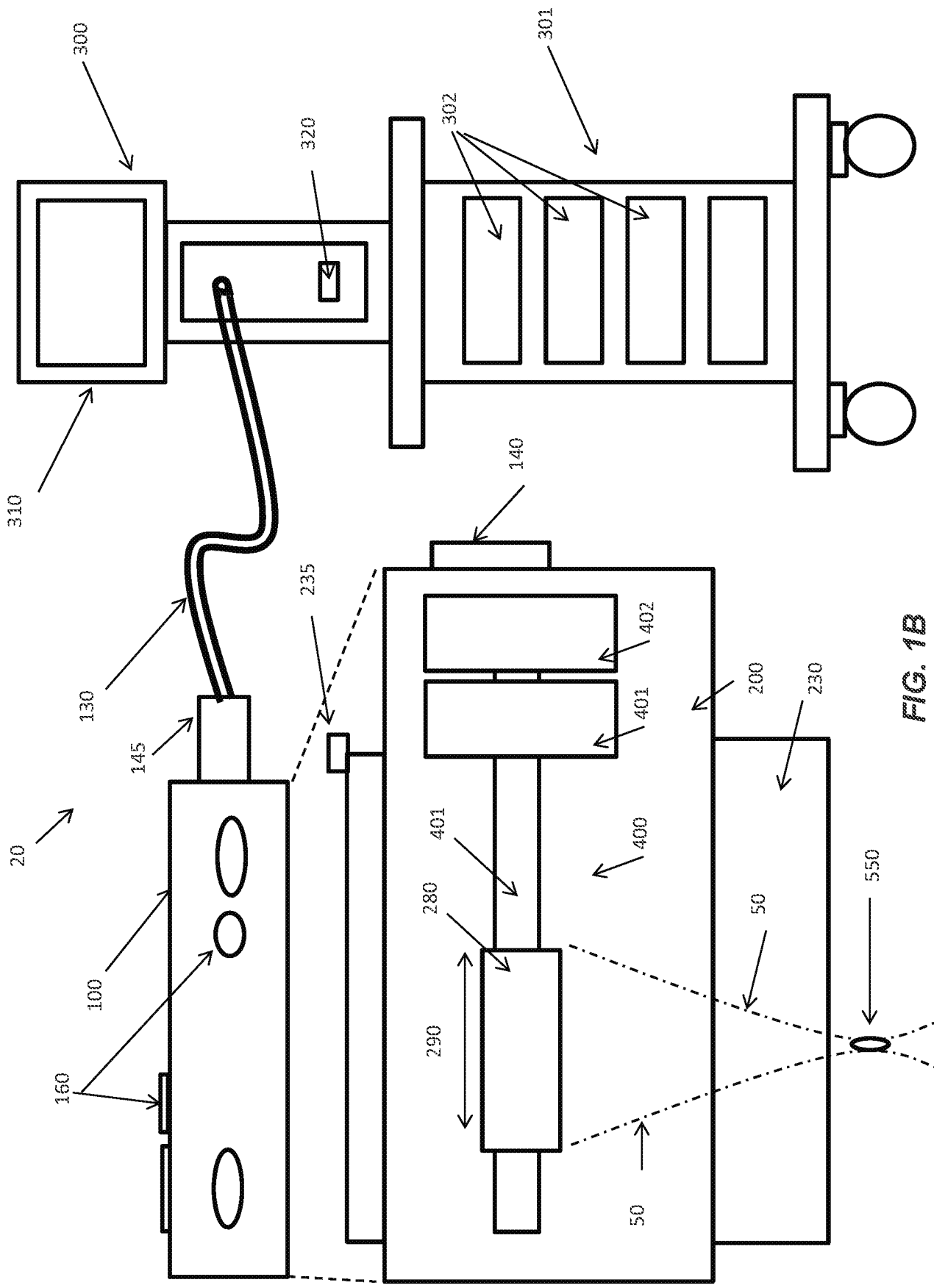

FIG. 1B

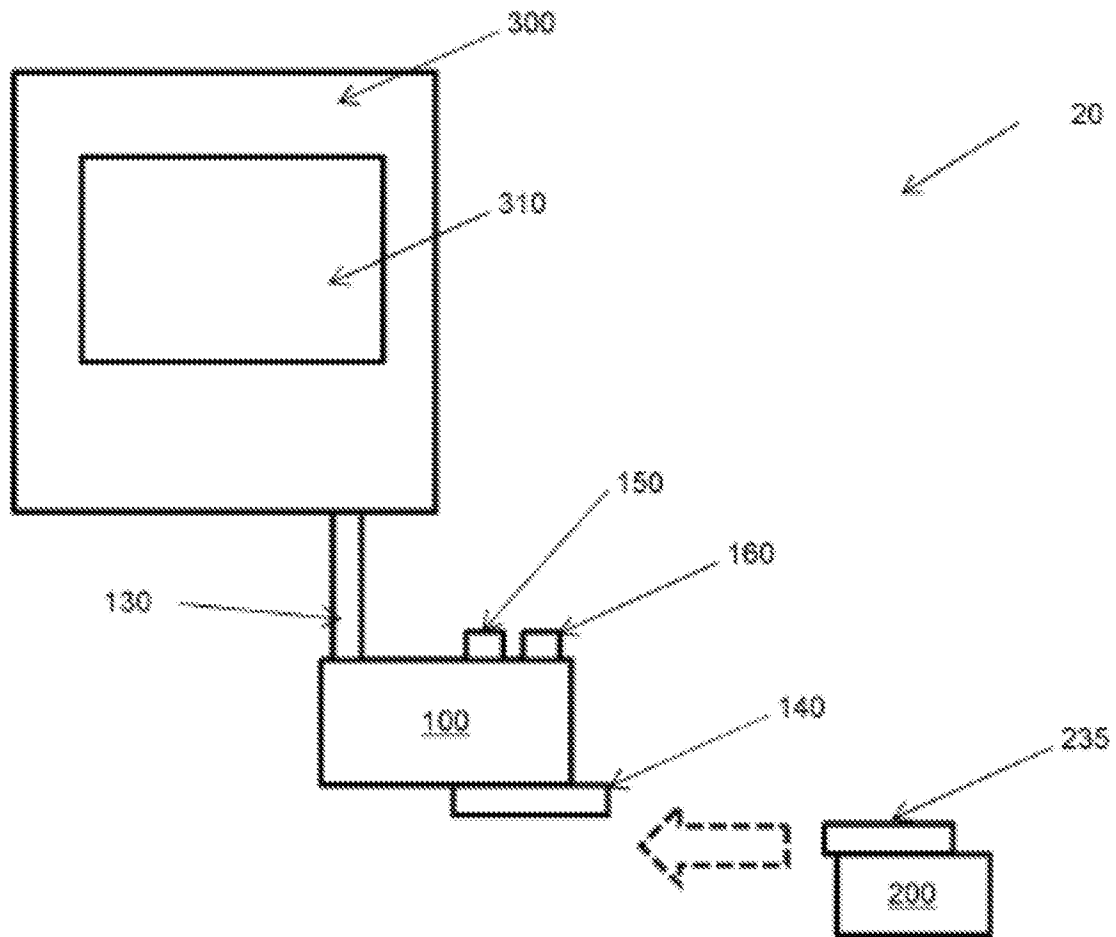

FIG. 1C

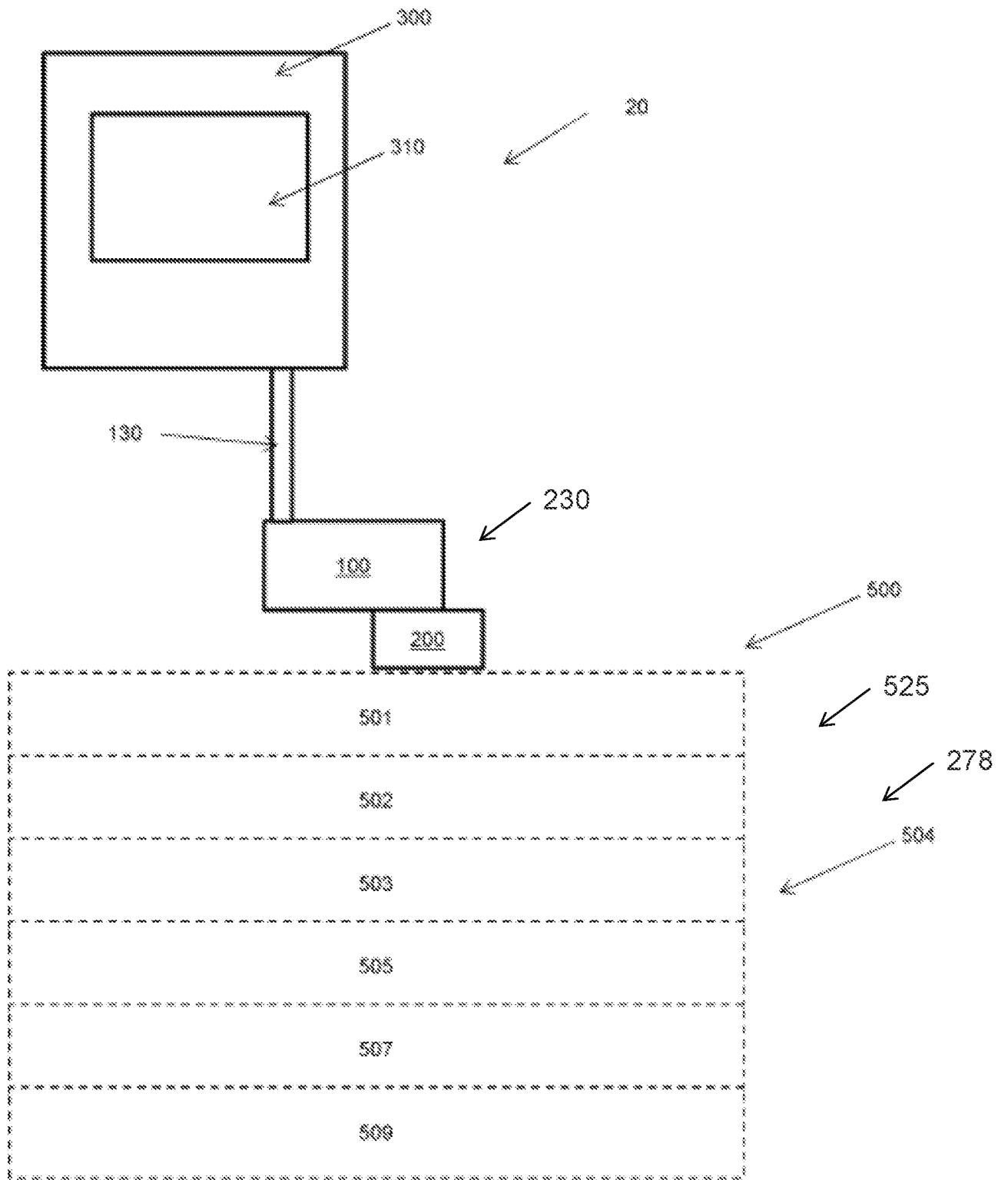

FIG. 2

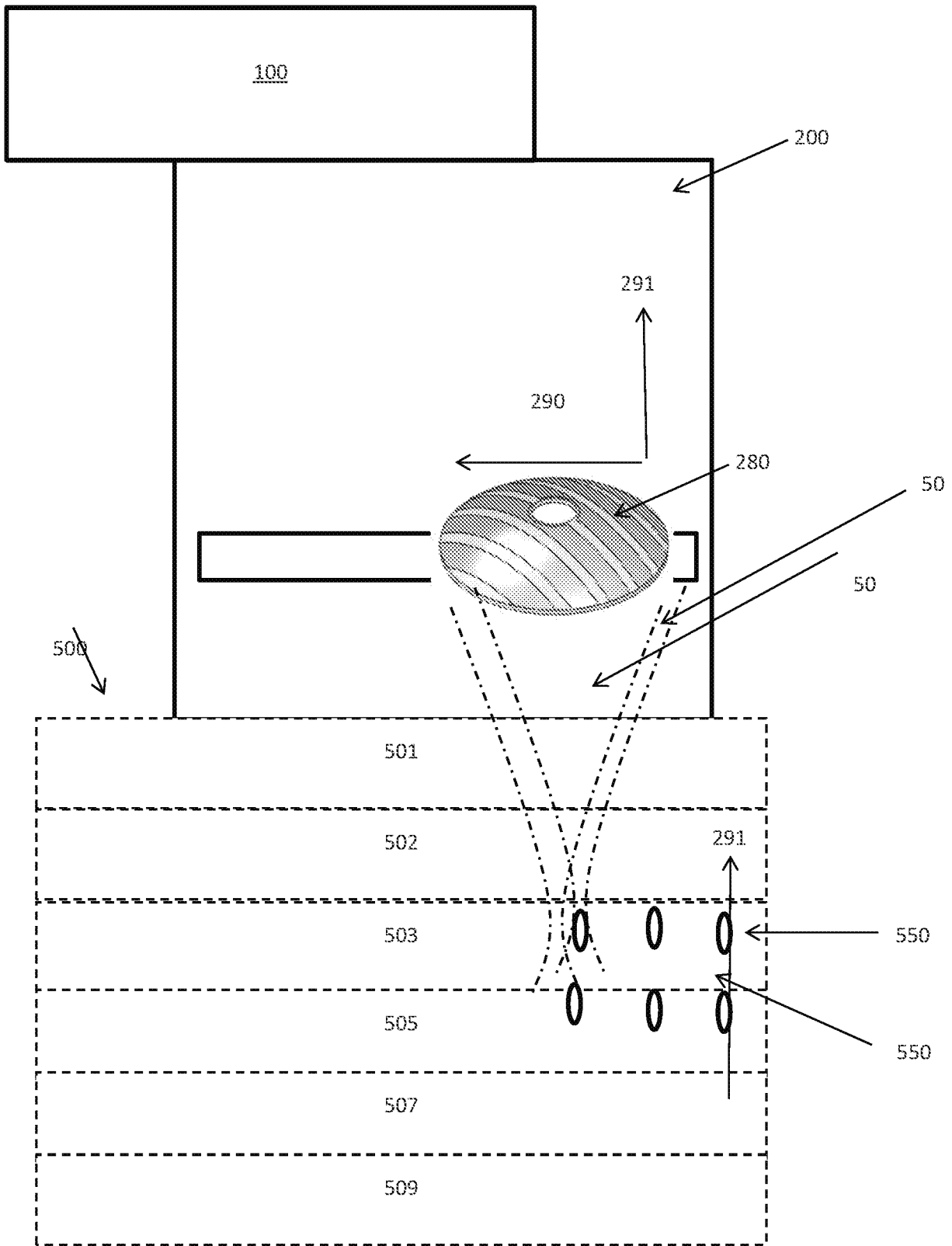

FIG. 3

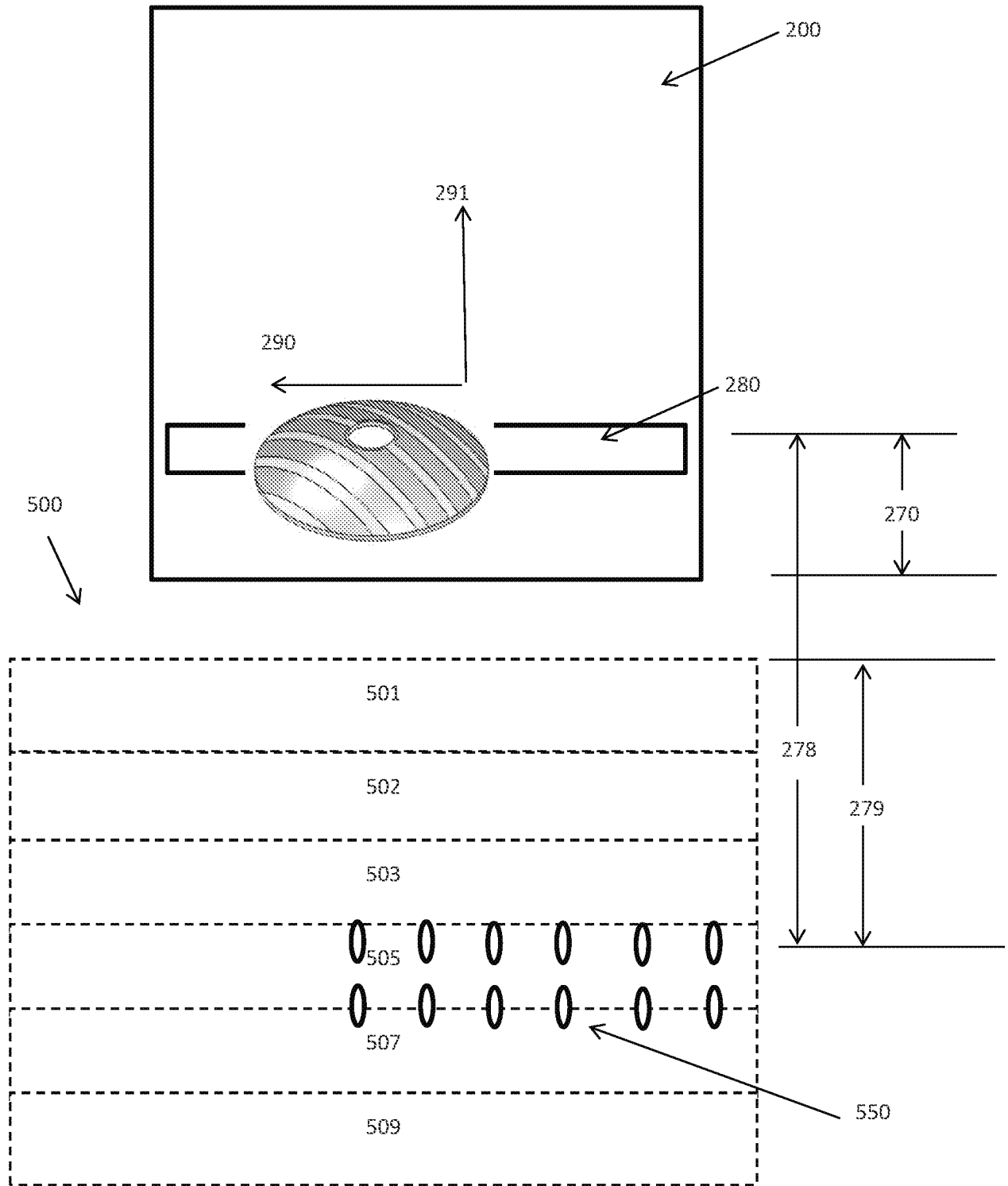

FIG. 4

TABLE 4

f [MHz]	$k_x = 0.5 \text{ mm}^{-1}$		$k_x = 1.0 \text{ mm}^{-1}$		$k_x = 1.5 \text{ mm}^{-1}$		$k_x = 2.0 \text{ mm}^{-1}$	
	spacing [mm]	spread [mm]	spacing [mm]	spread [mm]	spacing [mm]	spread [mm]	spacing [mm]	spread [mm]
2.5	1.43	0.72	2.86	1.43	4.30	2.15	5.73	2.86
2.75	1.30	0.59	2.60	1.17	3.91	1.76	5.21	2.34
3	1.19	0.48	2.39	0.95	3.58	1.43	4.77	1.91
3.25	1.10	0.39	2.20	0.77	3.31	1.16	4.41	1.54
3.5	1.02	0.31	2.05	0.61	3.07	0.92	4.09	1.23
3.75	0.95	0.24	1.91	0.48	2.86	0.72	3.82	0.95
4	0.90	0.18	1.79	0.36	2.69	0.54	3.58	0.72
4.25	0.84	0.13	1.69	0.25	2.53	0.38	3.37	0.51
4.5	0.80	0.08	1.59	0.16	2.39	0.24	3.18	0.32
4.75	0.75	0.04	1.51	0.08	2.26	0.11	3.02	0.15
5	0.72	0.00	1.43	0.00	2.15	0.00	2.86	0.00
5.25	0.68	-0.03	1.36	-0.07	2.05	-0.10	2.73	-0.14
5.5	0.65	-0.07	1.30	-0.13	1.95	-0.20	2.60	-0.26
5.75	0.62	-0.09	1.25	-0.19	1.87	-0.28	2.49	-0.37
6	0.60	-0.12	1.19	-0.24	1.79	-0.36	2.39	-0.48
6.25	0.57	-0.14	1.15	-0.29	1.72	-0.43	2.29	-0.57
6.5	0.55	-0.17	1.10	-0.33	1.65	-0.50	2.20	-0.66
6.75	0.53	-0.19	1.06	-0.37	1.59	-0.56	2.12	-0.74
7	0.51	-0.20	1.02	-0.41	1.53	-0.61	2.05	-0.82
7.25	0.49	-0.22	0.99	-0.44	1.48	-0.67	1.98	-0.89
7.5	0.48	-0.24	0.95	-0.48	1.43	-0.72	1.91	-0.95

FIG. 5

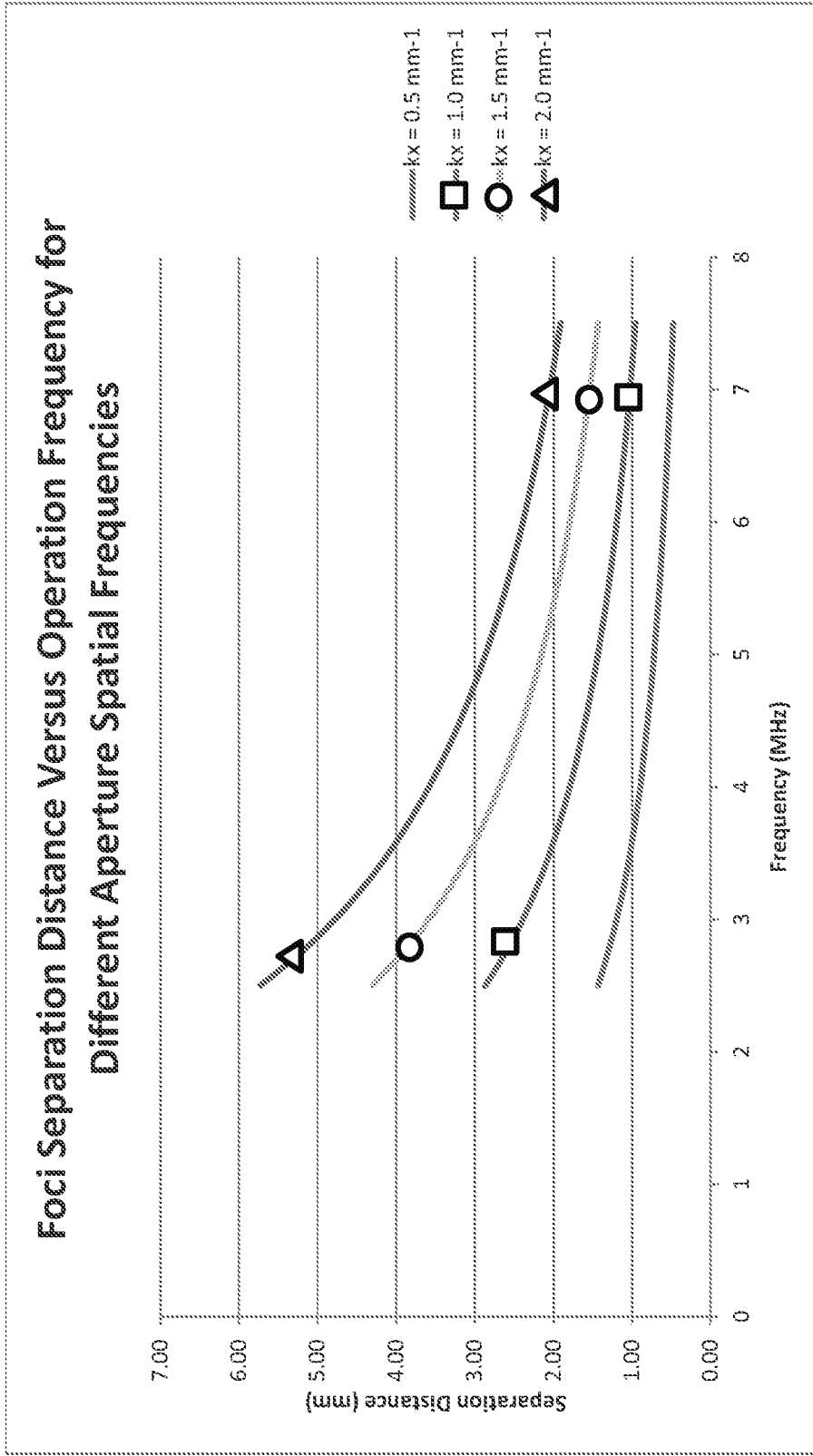

FIG. 6

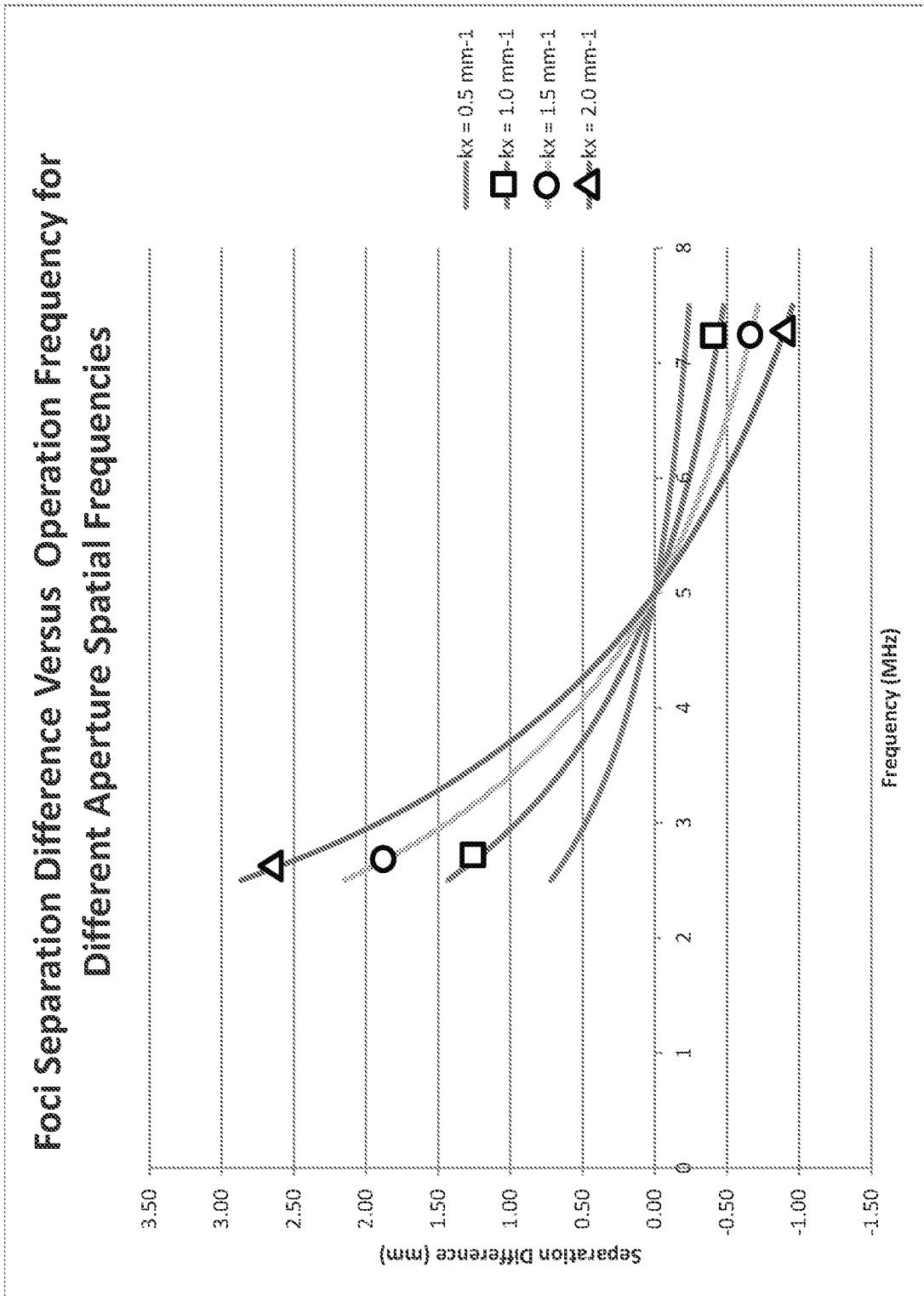

FIG. 7

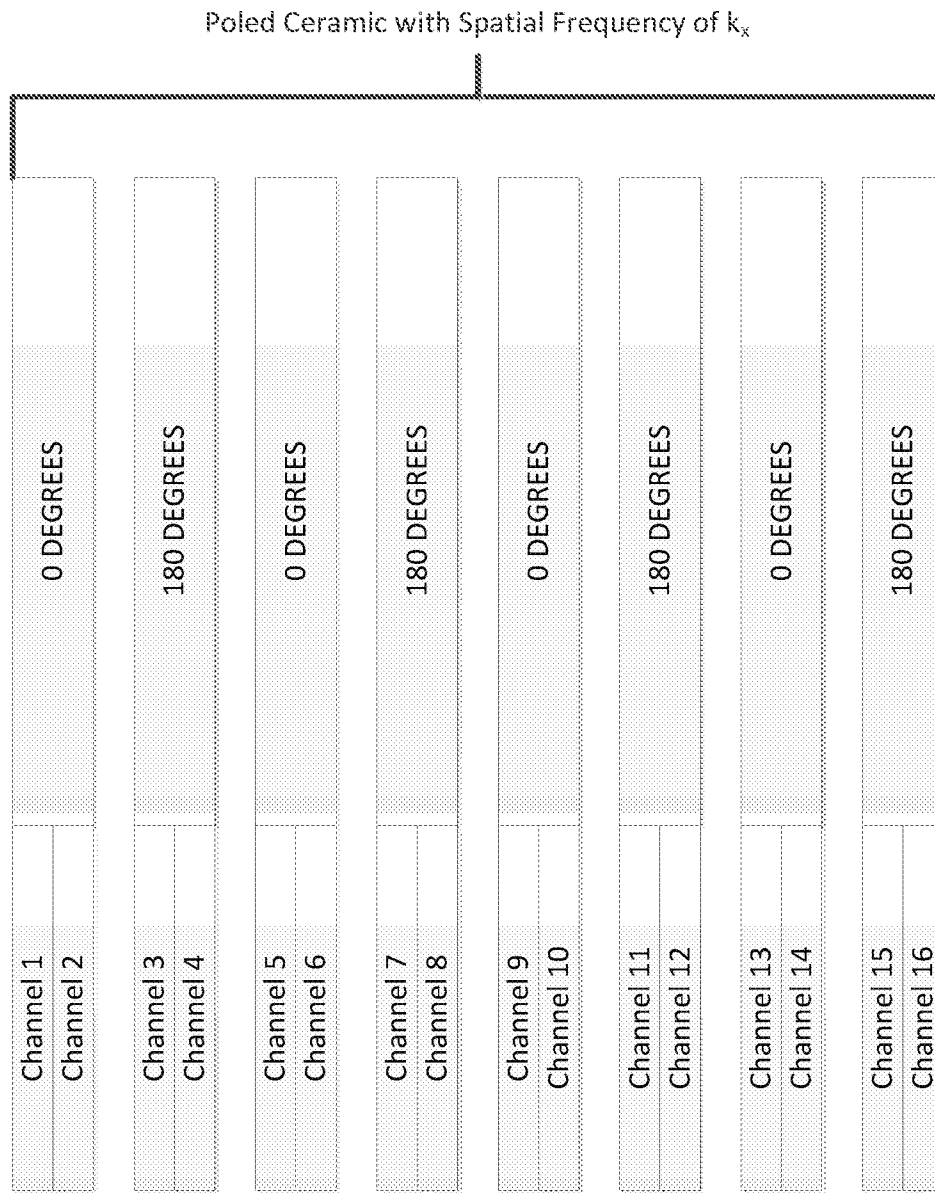

FIG. 8



FIG. 9

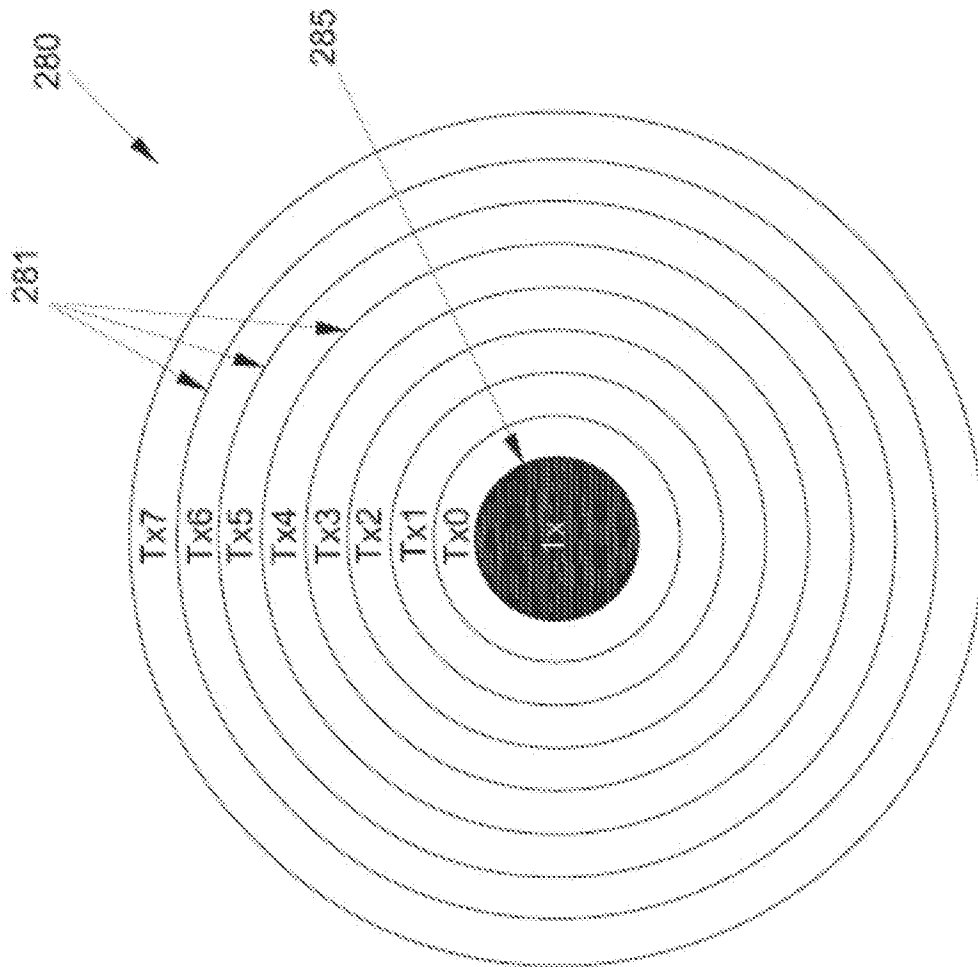

FIG. 10

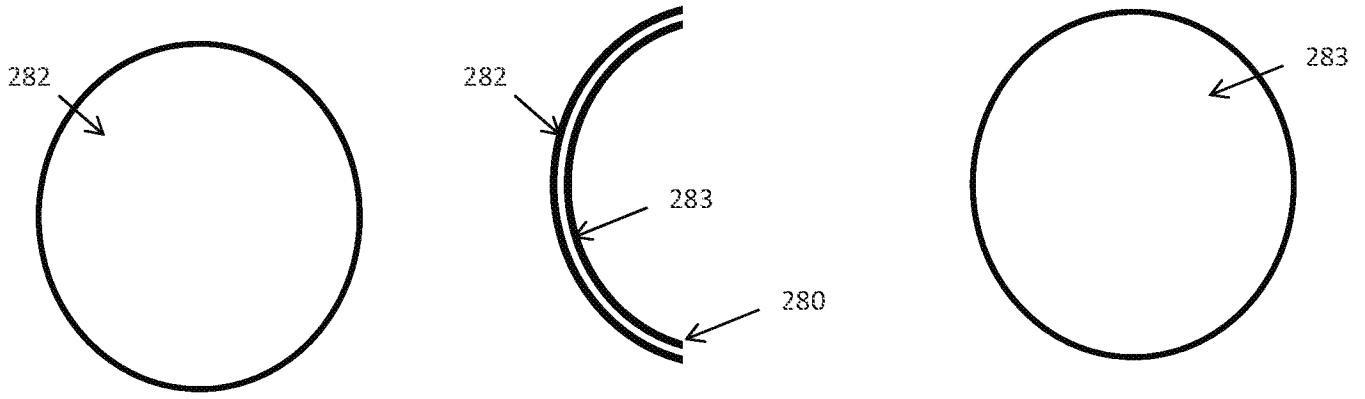

FIG. 11

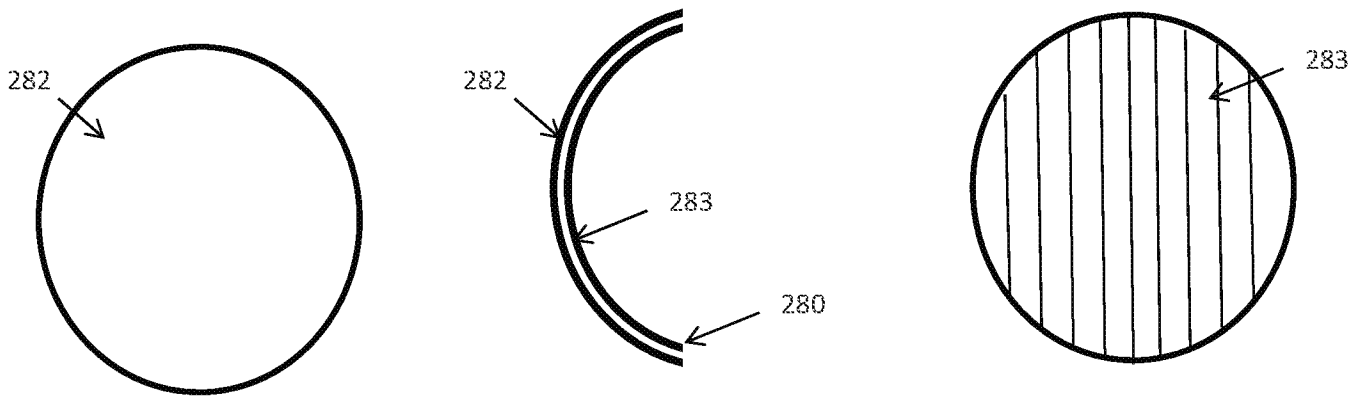

FIG. 12

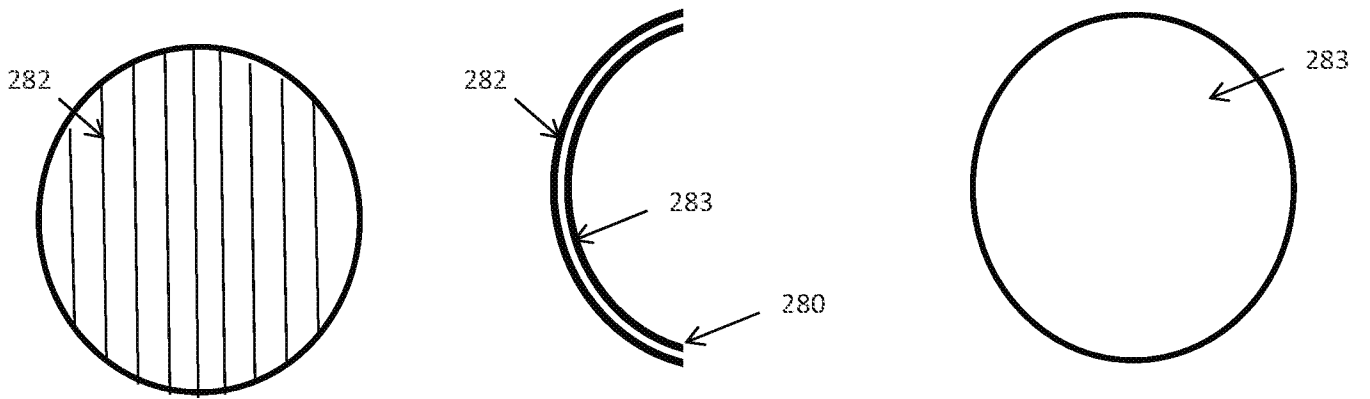

FIG. 13

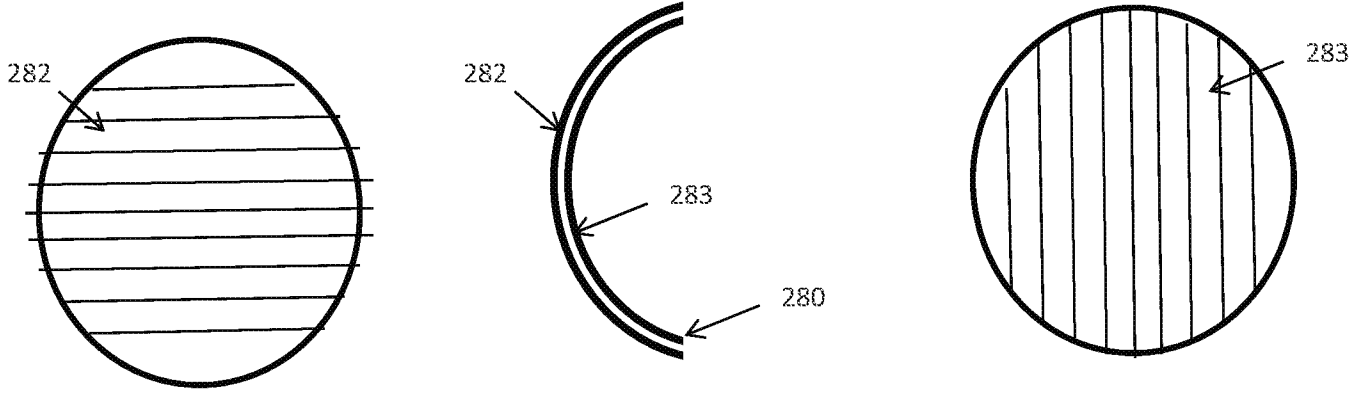

FIG. 14

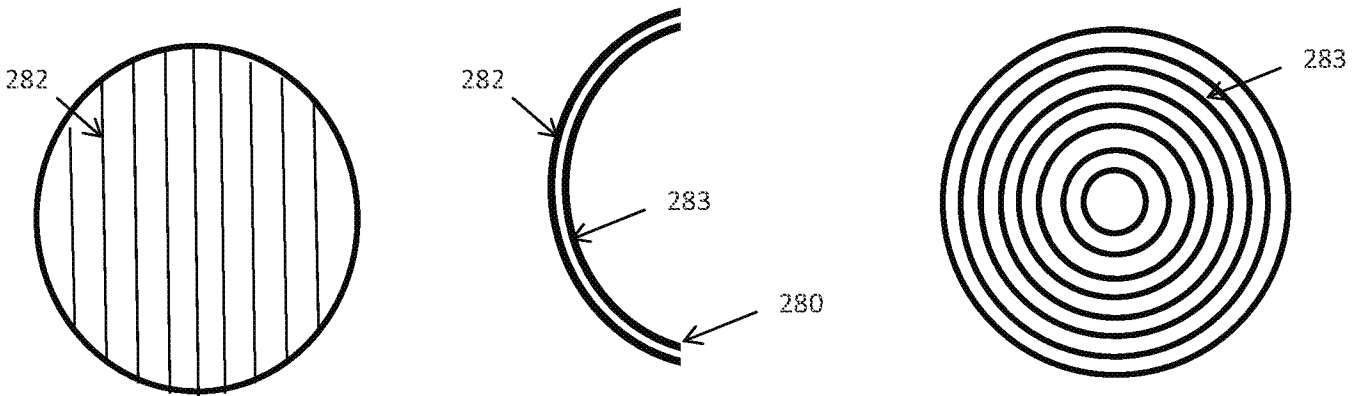

FIG. 15

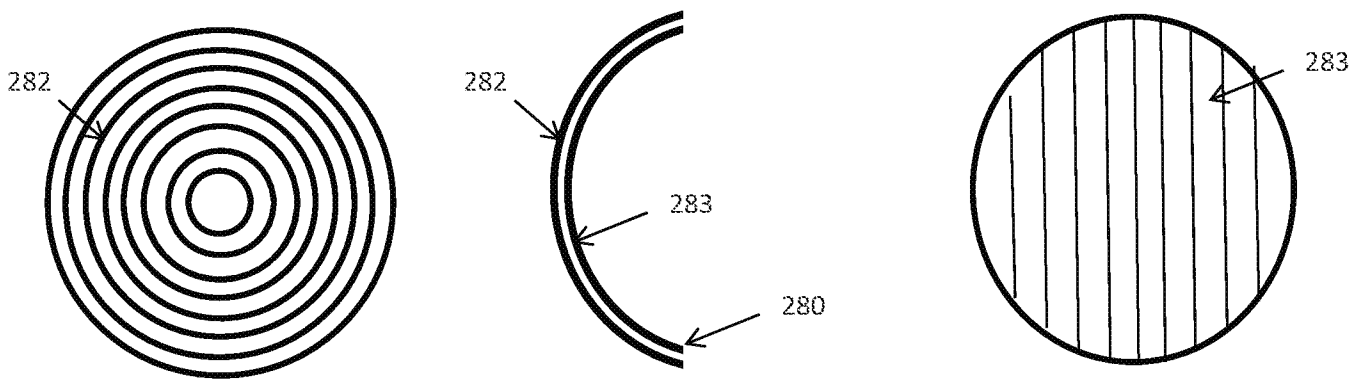
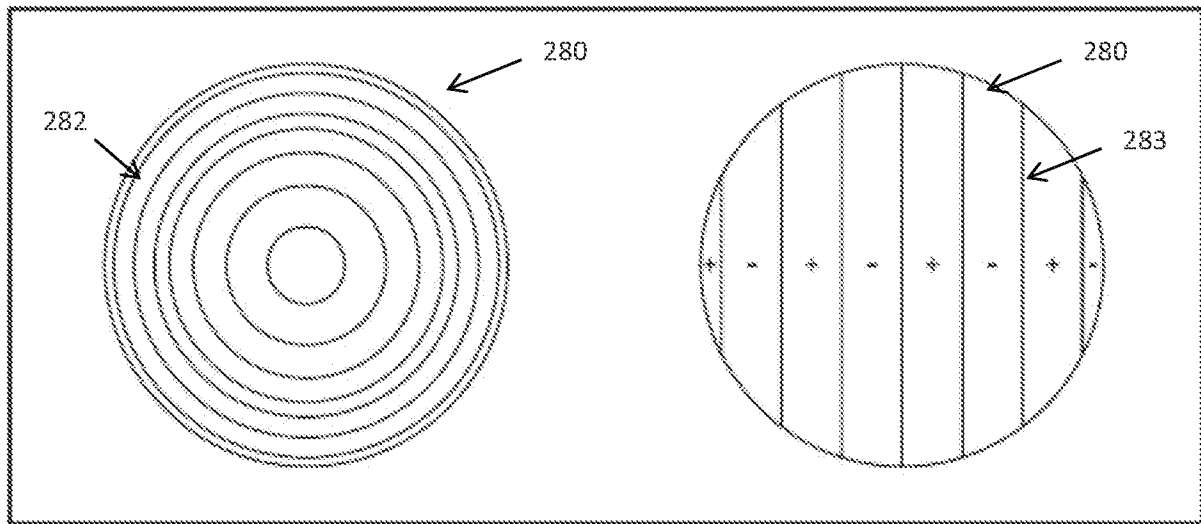

FIG. 16



Annular Array for Depth Control

Poling Stripes for Split Beam (Simulines)

FIG. 17

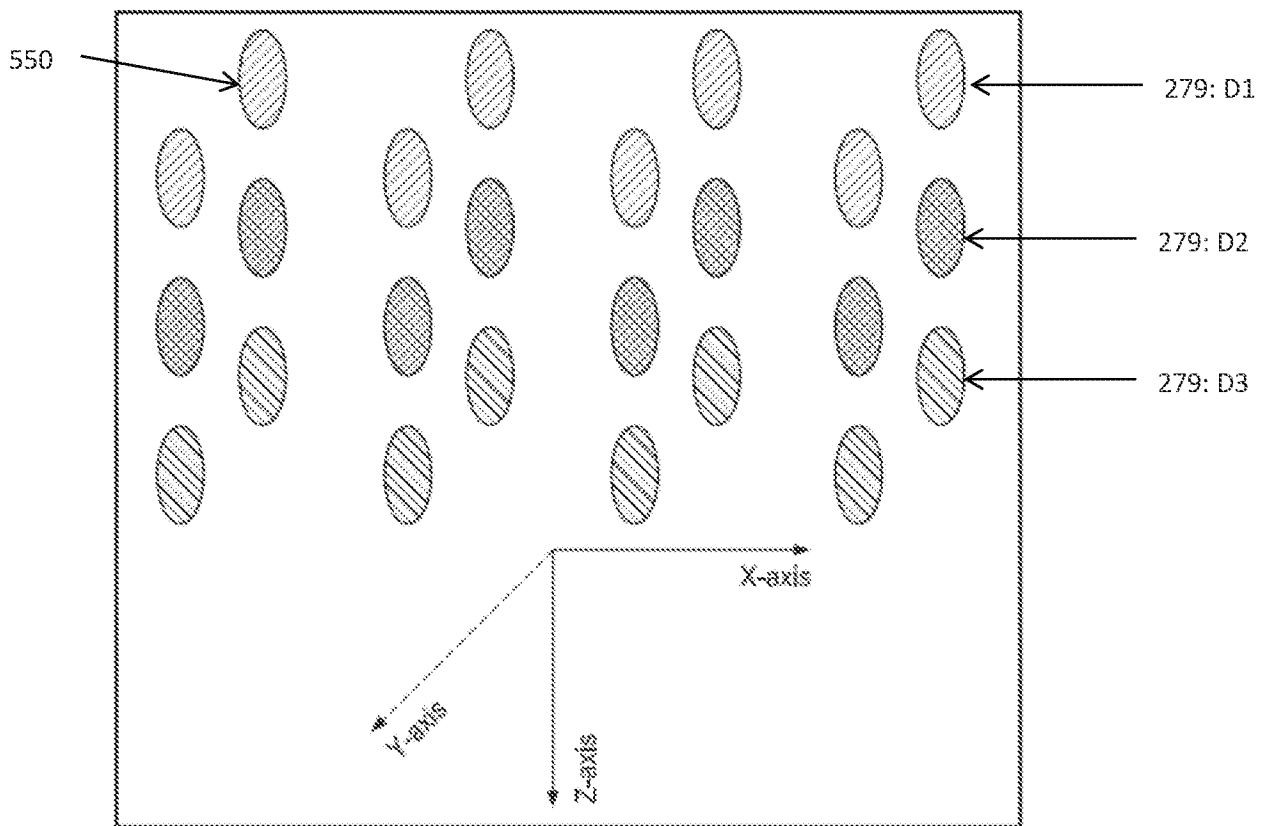

FIG. 18

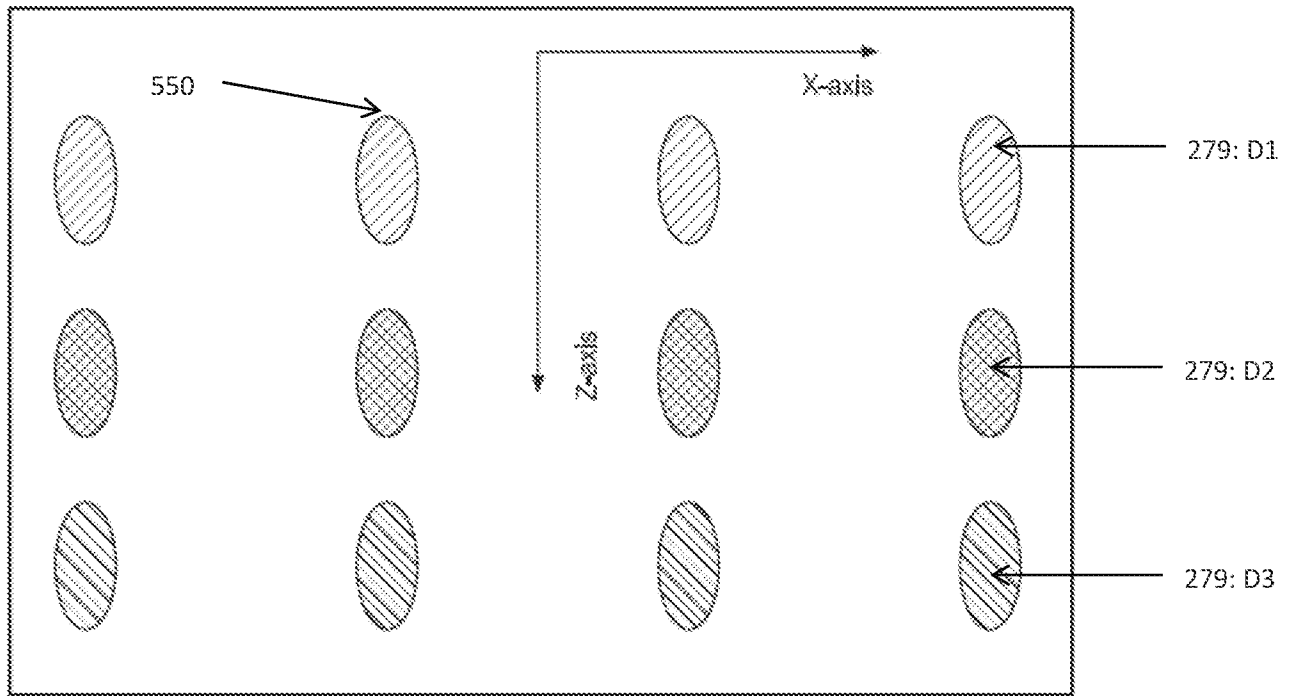

FIG. 19

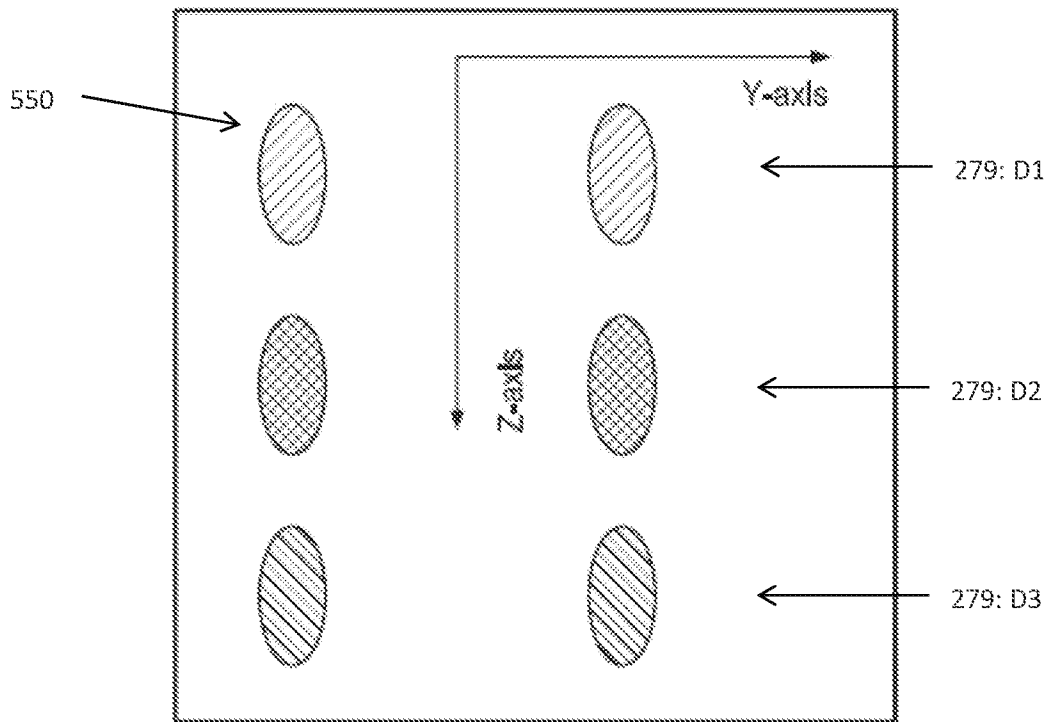

FIG. 20

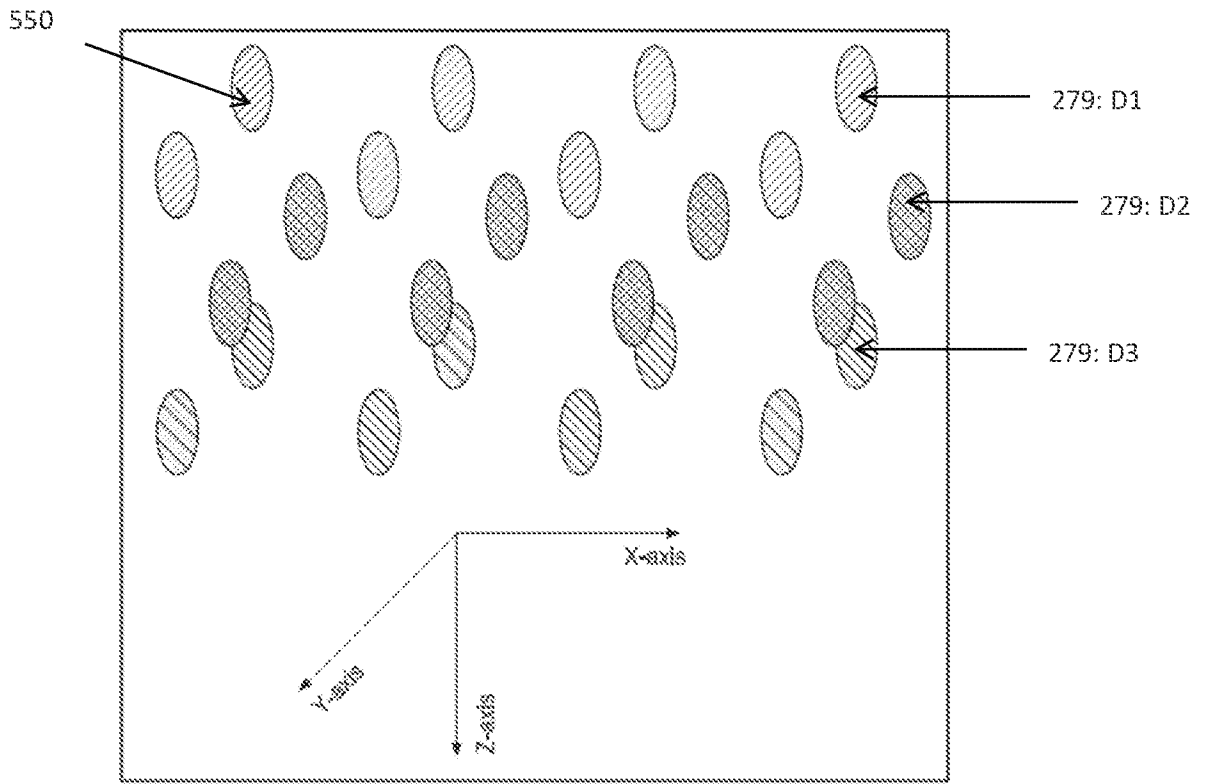

FIG. 21

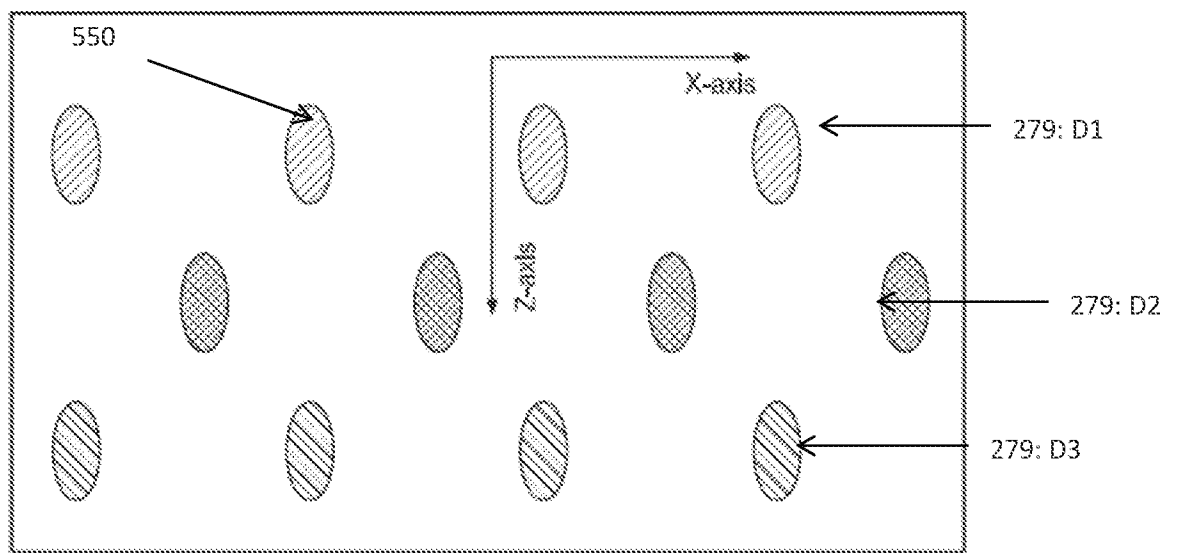

FIG. 22

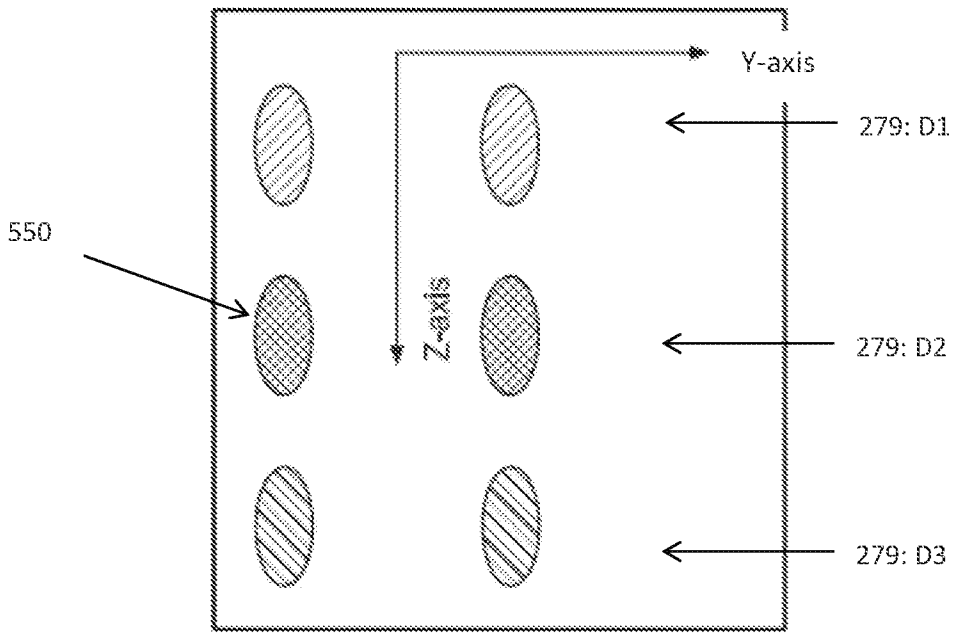

FIG. 23

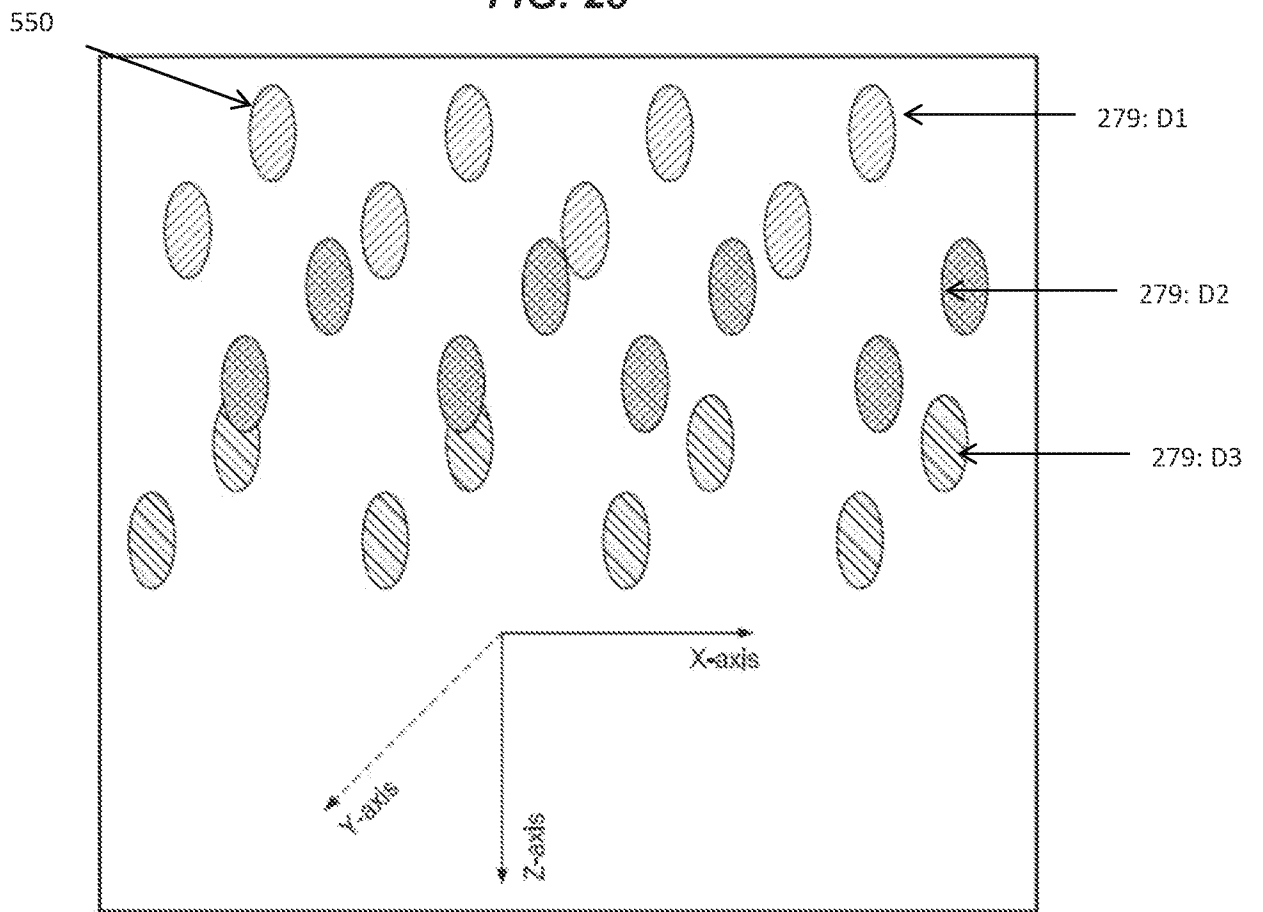

FIG. 24

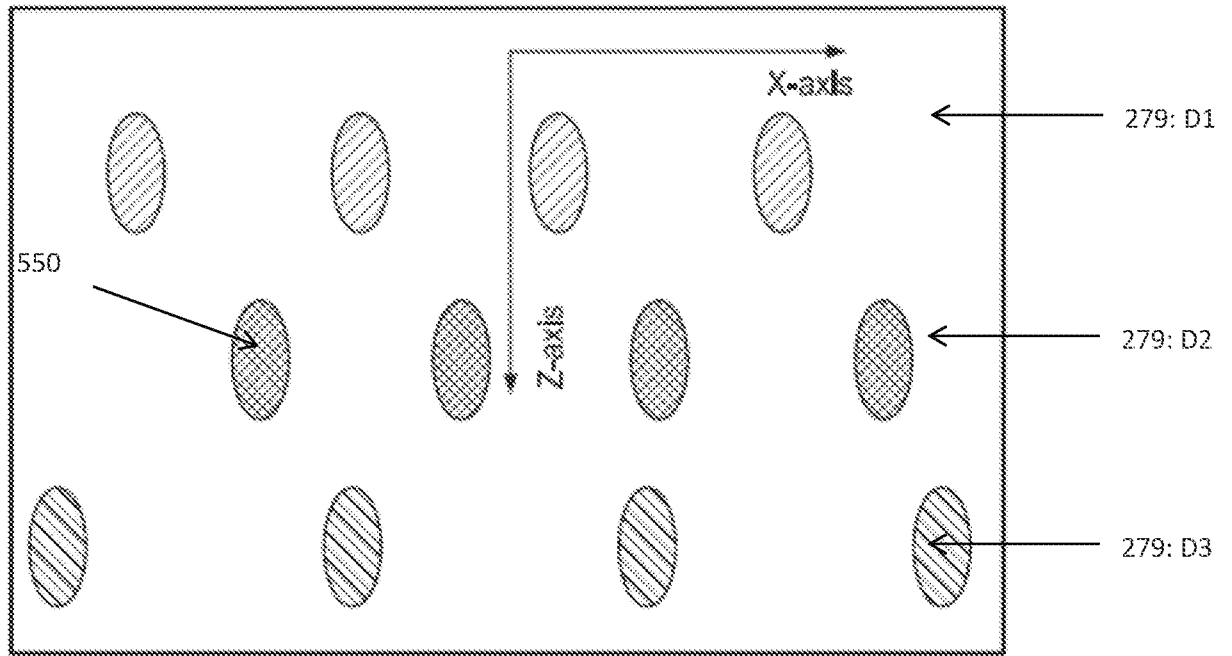

FIG. 25

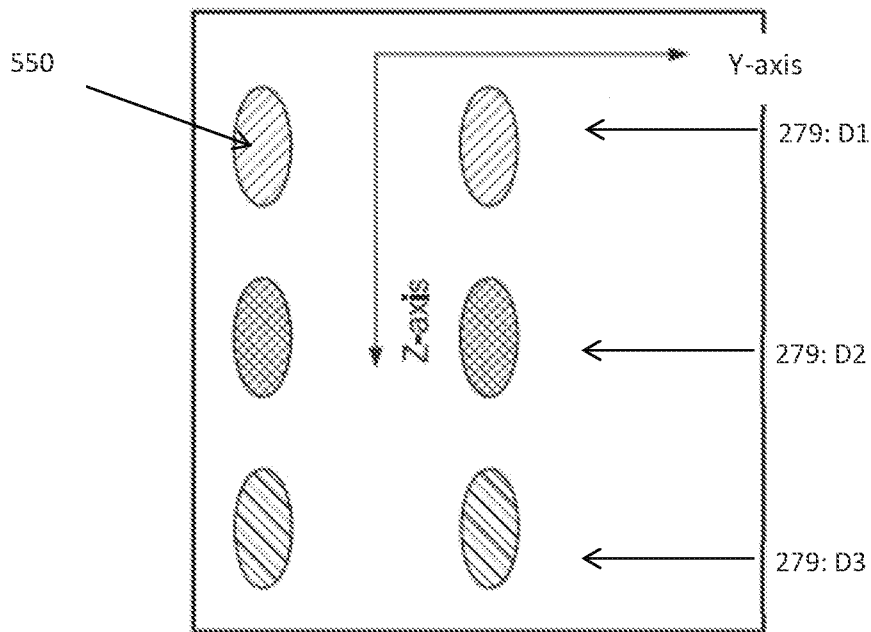

FIG. 26

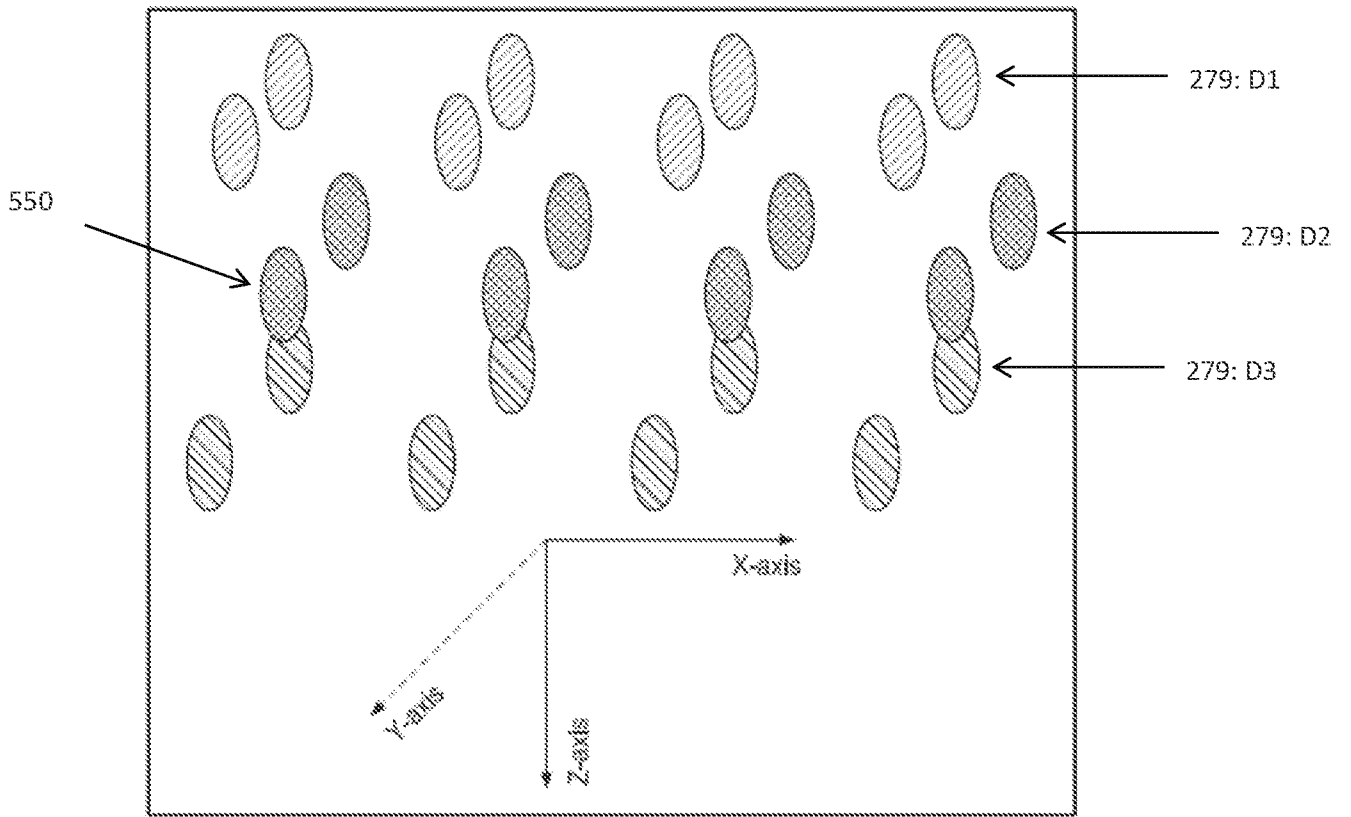

FIG. 27

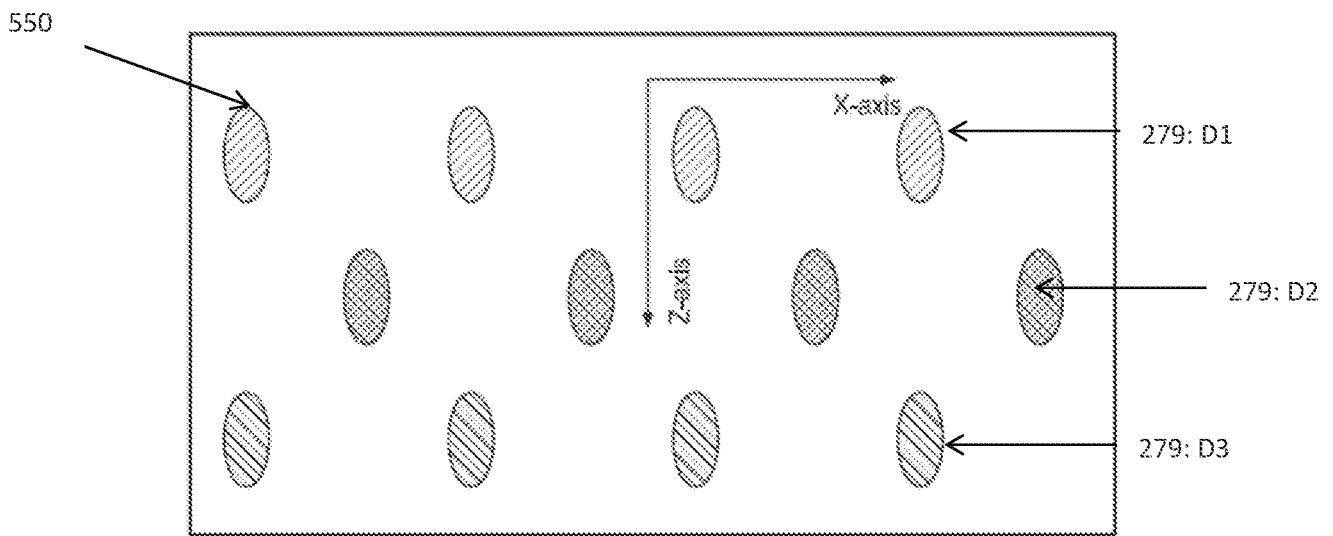

FIG. 28

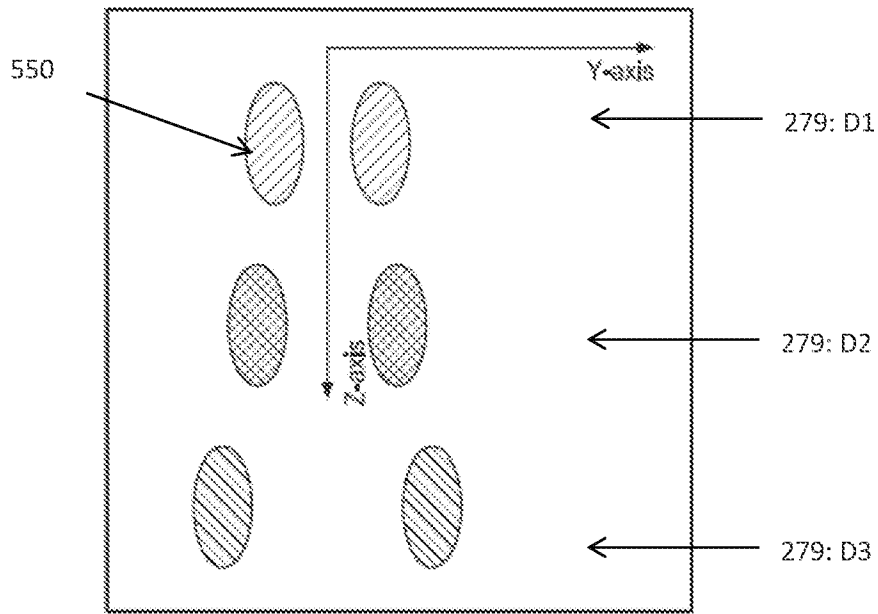
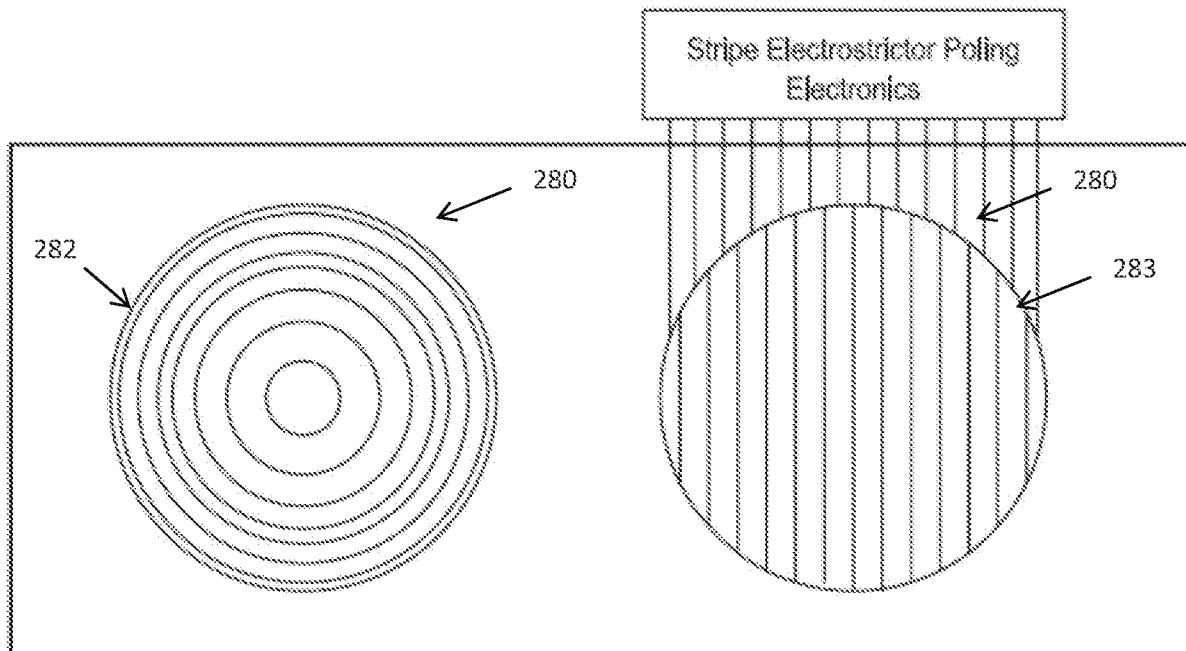

FIG. 29



Annular Array for
Depth Control

Electrostrictor
Stripes for Split Beam
(Simulines)

FIG. 30

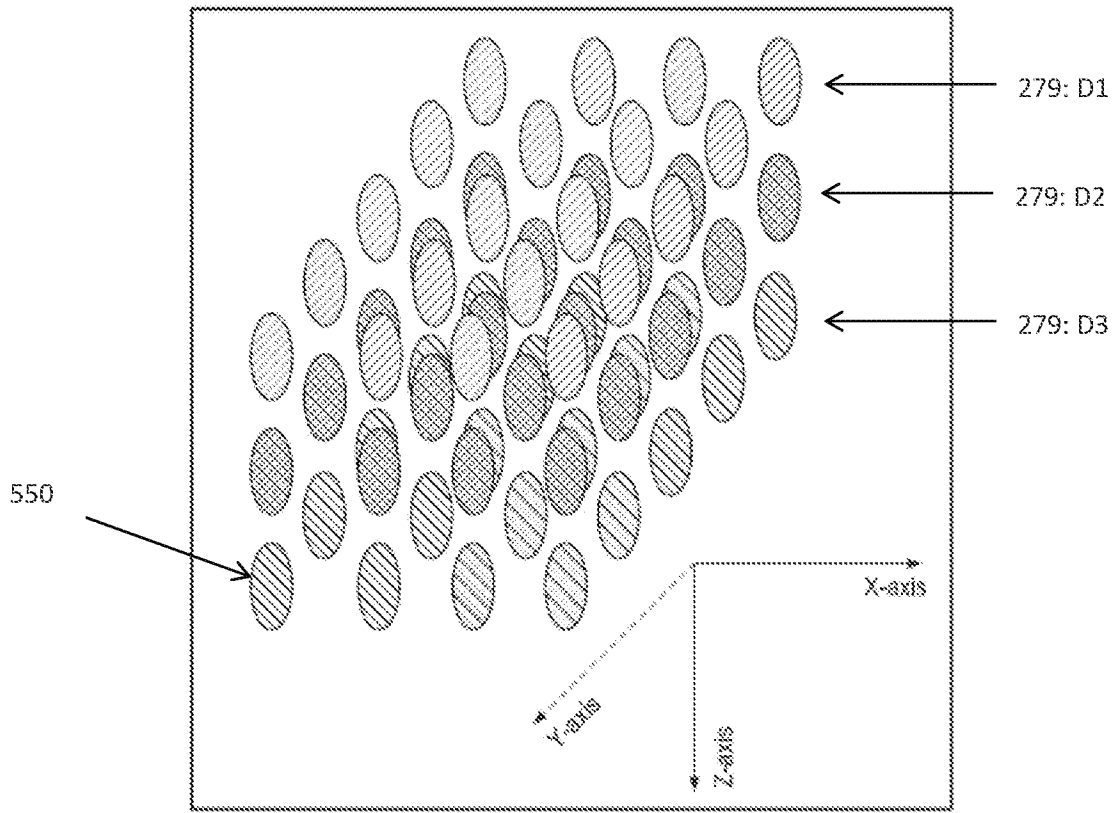

FIG. 31

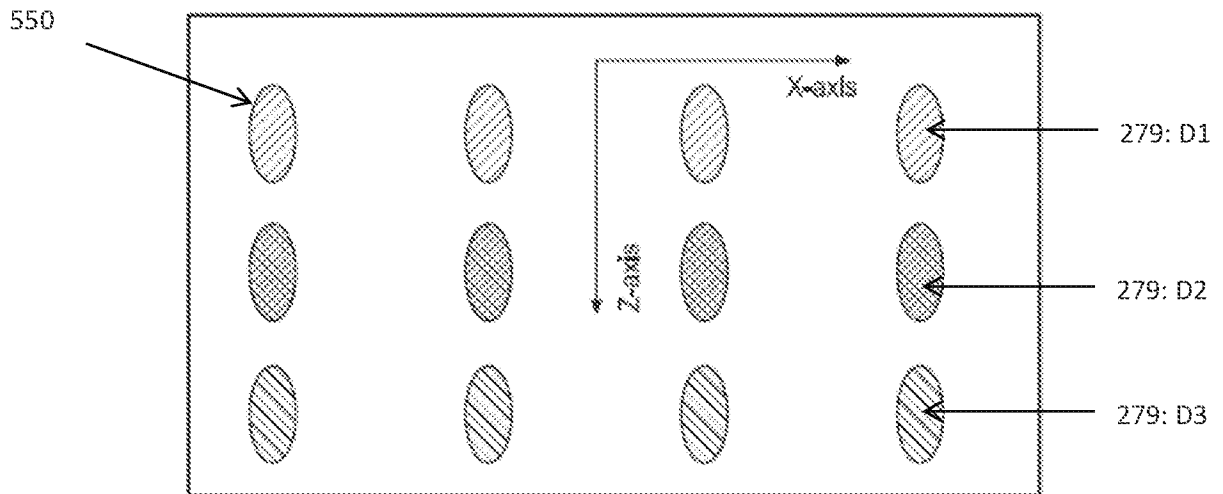

FIG. 32

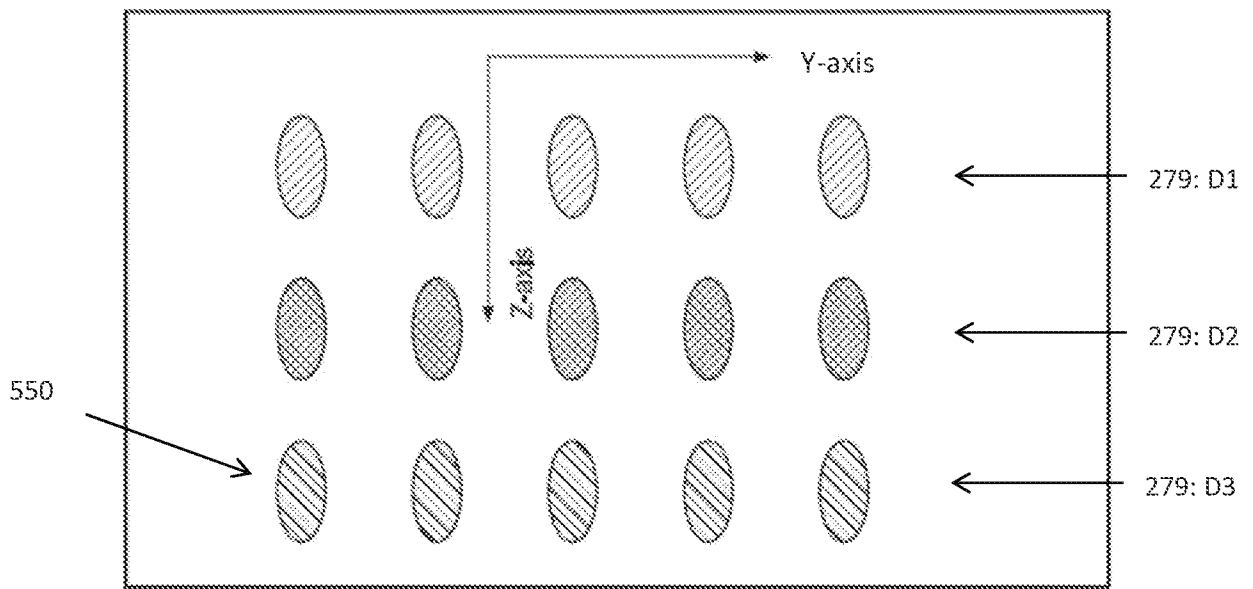

FIG. 33

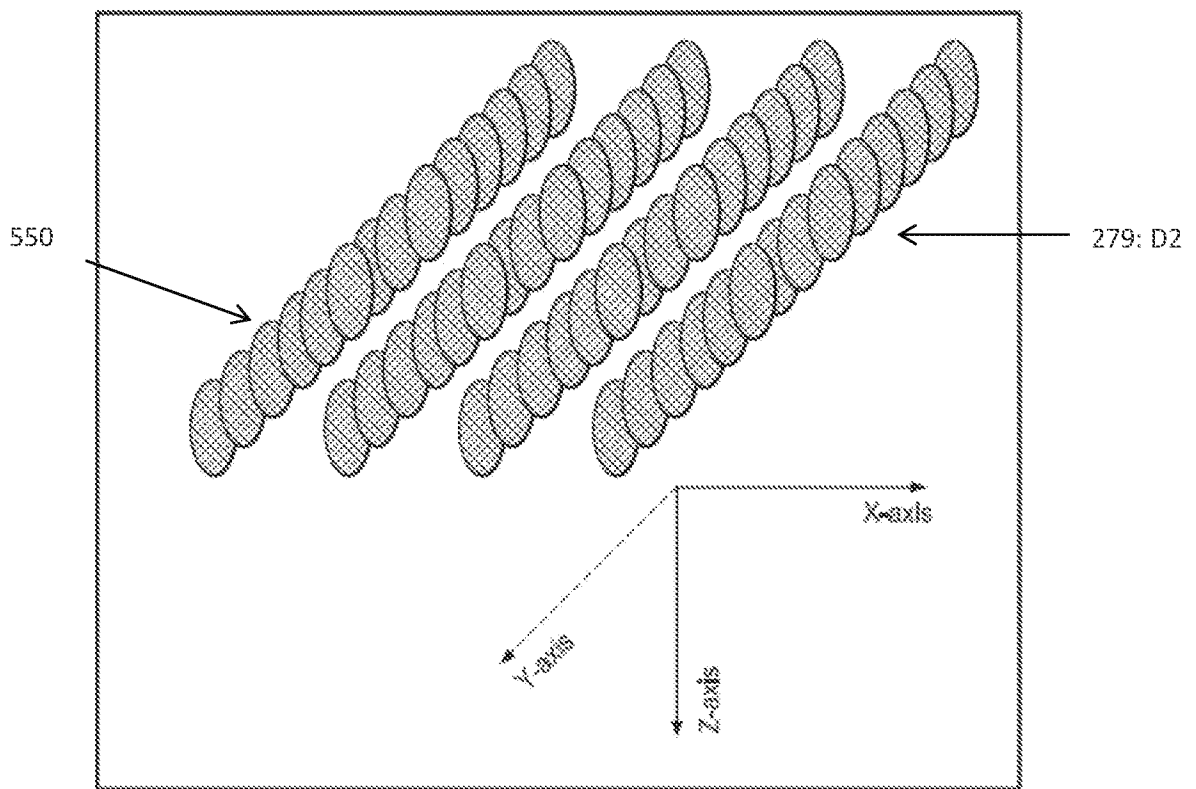

FIG. 34

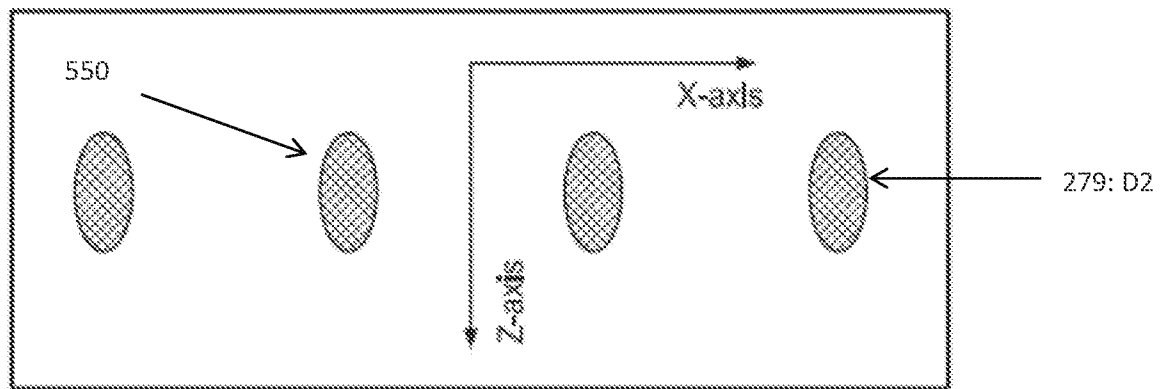

FIG. 35

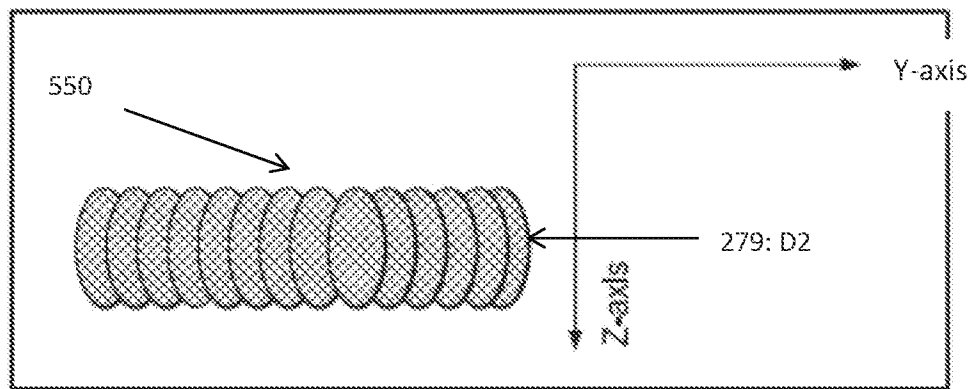

FIG. 36

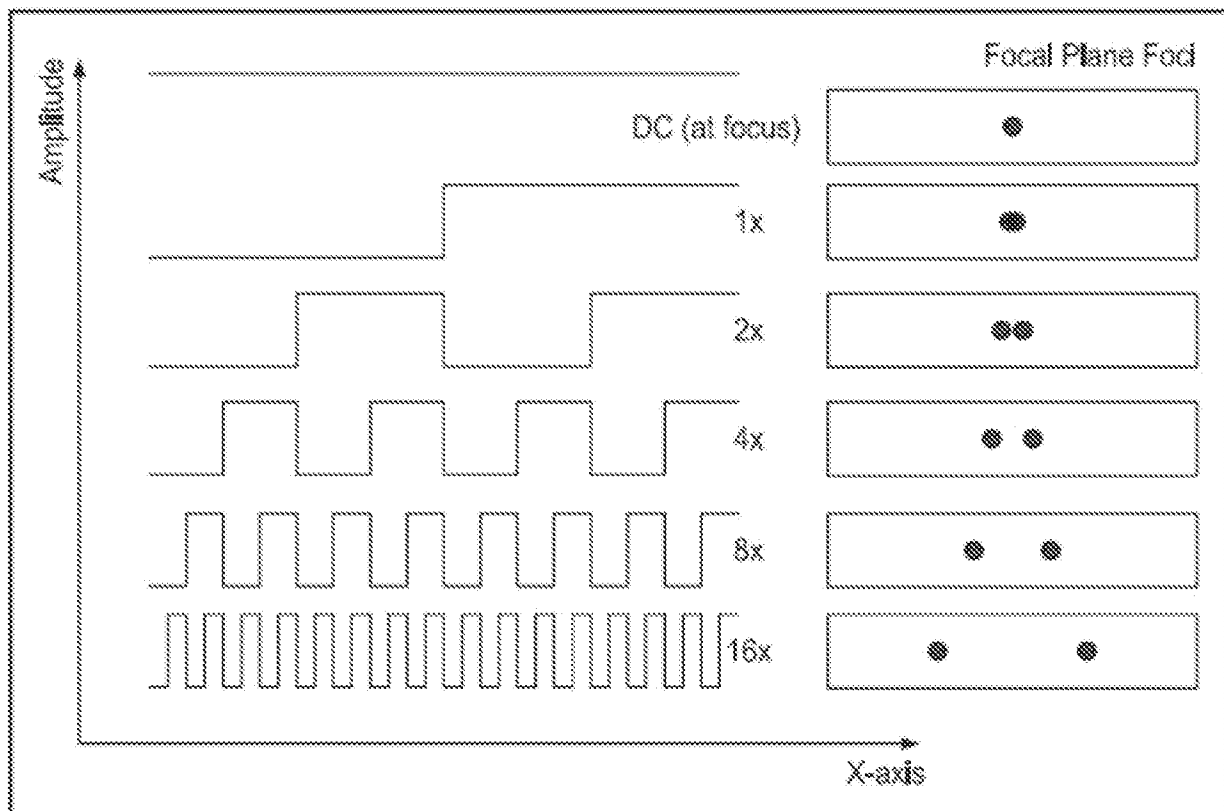

FIG. 37

INTERNATIONAL SEARCH REPORT

International application No.

PCT/US19/14617

A. CLASSIFICATION OF SUBJECT MATTER
 IPC - A61B 8/00, 18/00; A61N 7/00 (2019.01)
 CPC - A61B 8/4209; A61N 7/00, 7/02

According to International Patent Classification (IPC) or to both national classification and IPC

B. FIELDS SEARCHED

Minimum documentation searched (classification system followed by classification symbols)

See Search History document

Documentation searched other than minimum documentation to the extent that such documents are included in the fields searched

See Search History document

Electronic data base consulted during the international search (name of data base and, where practicable, search terms used)

See Search History document

C. DOCUMENTS CONSIDERED TO BE RELEVANT

Category*	Citation of document, with indication, where appropriate, of the relevant passages	Relevant to claim No.
X	US 2014/0257145 A1 (ULTHERA, INC.) 11 September, 2014; paragraphs [0007]-[0011], [0031], [0032], [0044], [0051], [0093], [0177]; claims 2, 4	1-17
A	US 2008/0082026 A1 (SCHMIDT, R et al.) 03 April, 2008; figures 1, 11; paragraphs [0002], [0004], [0006], [0024]	18-44
A	US 2013/0090579 A1 (CAIN, CA et al.) 11 April, 2013; figure 1a; paragraph [0043]; claim 1	18-31, 39-44
A	US 2013/0296743 A1 (LEE, CY et al.) 07 November, 2013; paragraphs [0035], [0040]; claim 9	32-38

Further documents are listed in the continuation of Box C.

See patent family annex.

* Special categories of cited documents:

"A" document defining the general state of the art which is not considered to be of particular relevance

"E" earlier application or patent but published on or after the international filing date

"L" document which may throw doubts on priority claim(s) or which is cited to establish the publication date of another citation or other special reason (as specified)

"O" document referring to an oral disclosure, use, exhibition or other means

"P" document published prior to the international filing date but later than the priority date claimed

"T" later document published after the international filing date or priority date and not in conflict with the application but cited to understand the principle or theory underlying the invention

"X" document of particular relevance; the claimed invention cannot be considered novel or cannot be considered to involve an inventive step when the document is taken alone

"Y" document of particular relevance; the claimed invention cannot be considered to involve an inventive step when the document is combined with one or more other such documents, such combination being obvious to a person skilled in the art

"&" document member of the same patent family

Date of the actual completion of the international search

22 March, 2019 (22.03.2019)

Date of mailing of the international search report

10 APR 2019

Name and mailing address of the ISA/

Mail Stop PCT, Attn: ISA/US, Commissioner for Patents
 P.O. Box 1450, Alexandria, Virginia 22313-1450
 Facsimile No. 571-273-8300

Authorized officer

Shane Thomas

PCT Helpdesk: 571-272-4300
 PCT OSP: 571-272-7774

INTERNATIONAL SEARCH REPORT

International application No.

PCT/US19/14617

Box No. II Observations where certain claims were found unsearchable (Continuation of item 2 of first sheet)

This international search report has not been established in respect of certain claims under Article 17(2)(a) for the following reasons:

1. Claims Nos.:
because they relate to subject matter not required to be searched by this Authority, namely:

2. Claims Nos.:
because they relate to parts of the international application that do not comply with the prescribed requirements to such an extent that no meaningful international search can be carried out, specifically:

3. Claims Nos.: 45-50
because they are dependent claims and are not drafted in accordance with the second and third sentences of Rule 6.4(a).

Box No. III Observations where unity of invention is lacking (Continuation of item 3 of first sheet)

This International Searching Authority found multiple inventions in this international application, as follows:

1. As all required additional search fees were timely paid by the applicant, this international search report covers all searchable claims.
2. As all searchable claims could be searched without effort justifying additional fees, this Authority did not invite payment of additional fees.
3. As only some of the required additional search fees were timely paid by the applicant, this international search report covers only those claims for which fees were paid, specifically claims Nos.:

4. No required additional search fees were timely paid by the applicant. Consequently, this international search report is restricted to the invention first mentioned in the claims; it is covered by claims Nos.:

Remark on Protest

- The additional search fees were accompanied by the applicant's protest and, where applicable, the payment of a protest fee.
- The additional search fees were accompanied by the applicant's protest but the applicable protest fee was not paid within the time limit specified in the invitation.
- No protest accompanied the payment of additional search fees.