

Jan. 30, 1940.

H. Z. GORA

2,188,713

VALVE CORE, CONTAINER, AND STEM

Filed June 21, 1937

2 Sheets-Sheet 1

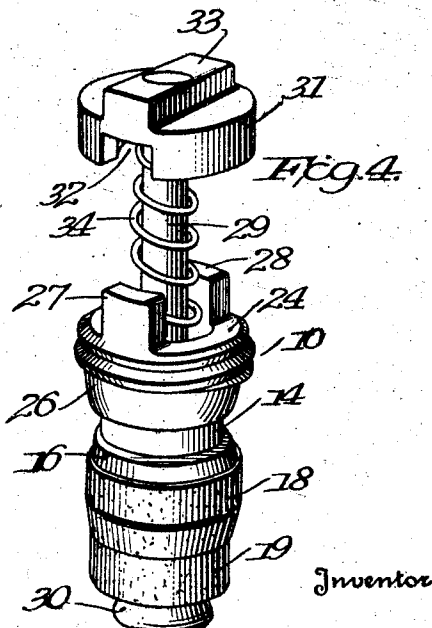
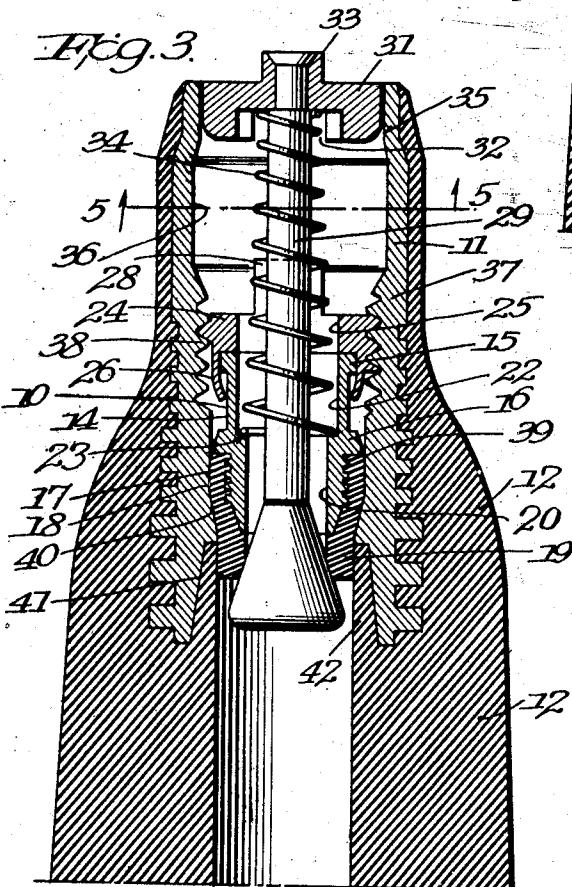
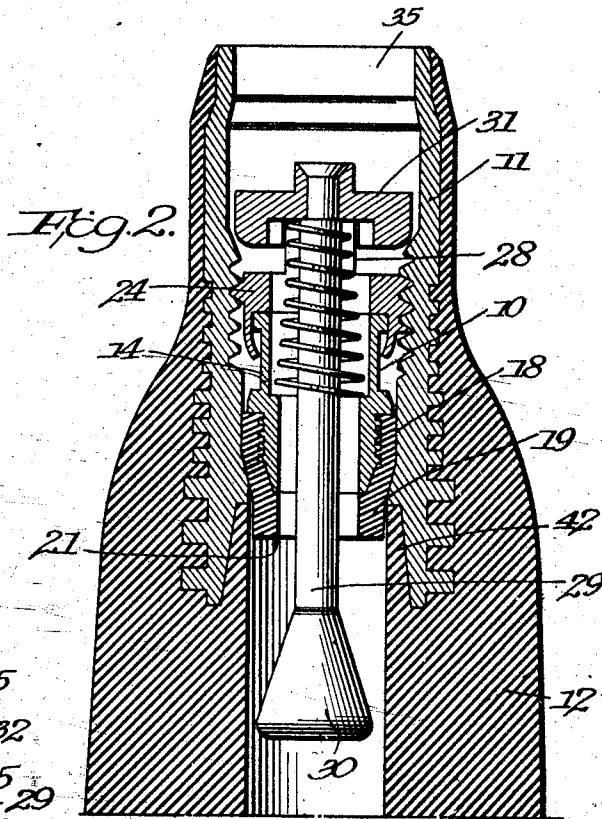
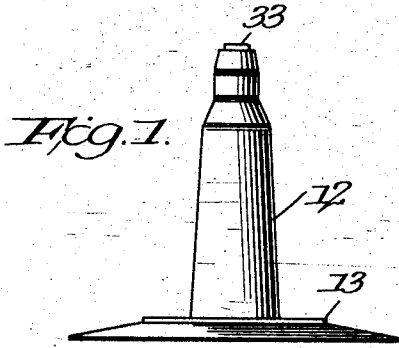

Inventor
Henry Z. Gora,

By *Leckman, Dady & Leckman*
Attorneys

Jan. 30, 1940.

H. Z. GORA

2,188,713

VALVE CORE, CONTAINER, AND STEM

Filed June 21, 1937

2 Sheets-Sheet 2

Fig. 5.

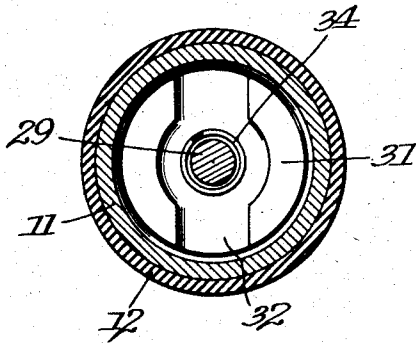

Fig. 6.

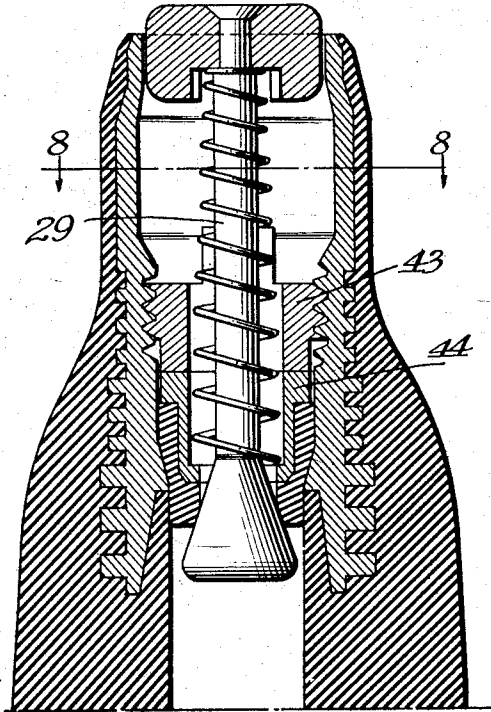

Fig. 7.

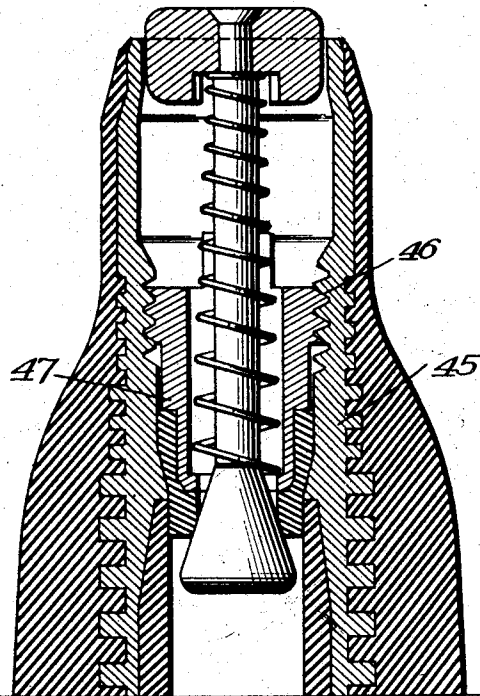
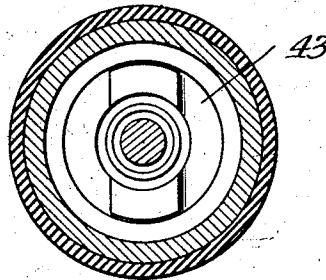

Fig. 8.



Inventor

Henry Z. Gora.

By *Levinson, Dwyer & Levinson*
Attorneys

UNITED STATES PATENT OFFICE

2,188,713

VALVE CORE, CONTAINER, AND STEM

Henry Z. Gora, Bridgeport, Conn., assignor to
Jenkins Bros., Bridgeport, Conn., a corpora-
tion of New Jersey

Application June 21, 1937, Serial No. 149,536

11 Claims. (Cl. 277-42)

The present invention relates to valve cores, core containers, and to valve stems, particularly rubber valve stems having the cores and containers associated therewith, a principal object of the invention being to provide a valve stem, preferably capless, with simplified but efficient removable valve provisions. I shall describe practical embodiments of the invention, by way of example, with reference to the accompanying drawings in which:

Figure 1 is an elevation of a rubber valve stem embodying the invention;

Figure 2 is an enlarged axial section of the tip end of the stem of Figure 1;

Figure 3 is a section similar to that of Figure 2 but with the valve parts in different relation;

Figure 4 is a perspective view of the new core;

Figure 5 is a section substantially on line 5-5 of Figure 3;

Figure 6 is a view similar to that of Figure 3 but showing a slightly modified form of core;

Figure 7 is a view similar to that of Figure 3 but showing another modification of the core and a modified core container, and

Figure 8 is a section on line 8-8 of Figure 6. Referring first to Figures 1 to 5, the new core is designated generally by the reference numeral 10. The core is shown by itself in Figure 4 and in operative association with a container 11 in Figures 2 and 3, the container 11 in these figures being shown as disposed in the tip portion of a flexible rubber valve stem body 12 which as shown in Figure 1 rises from a base flap 13.

The core 10 comprises a barrel 14 which has a top external flange 15, a medial external flange 16, and circumferential fins or ribs 17 below the flange 16, the lower extremity of the barrel being tapered to a substantially line edge. Secured to the barrel below the flange 16, preferably by vulcanization in a molding operation, is a tubular rubber body 18 which constitutes a part of the barrel. Externally the rubber body 18 is substantially cylindrical at its upper portion, being tapered therefrom to a lower depending skirt portion 19 of restricted diameter, the portion 19 as here shown being cylindrical externally and internally and being internally flush with the lower portion 20 of the barrel bore. At its extremity the skirt portion 19 has a sharp inner edge 21. The bore 20 is surmounted by a bore portion 22 of larger diameter so that a shoulder or ledge 23 is provided.

An externally threaded plug portion 24 has a bore 25 of the same size as the bore portion 22 and has a smooth depending skirt 26 whose

lower portion is spun over the flange 15 so that the plug portion and barrel are swiveled together. The plug portion 24 has a pair of diametrically opposite upstanding similar lugs 27 and 28 formed thereon.

A valve pin 29 is positioned within the barrel and plug portion to be freely axially movable relative thereto and carries at its lower end a conical valve body 30 which is preferably formed integral therewith. The valve body 30 is of a size to cooperate with the edge 21 as a seat and is proportioned to extend in both directions past the seat when operatively engaged with the latter as shown in Figure 3.

The upper reduced end of the pin 29 is received in a central opening in a circular head 31, the extremity of the pin being riveted over as here shown in order to secure the parts together. At its underside the head is provided with a diametrical groove 32 whose end walls are spaced apart a distance which is slightly greater than the width of the lugs 27 and 28, the central portion of the groove being somewhat expanded as shown in Figure 5. The top of head 31 has formed thereon a transverse rib 33. Interposed between the top wall of groove 32 and ledge 23 is a volute compression spring 34 which acts to pull the valve body 30 against the seat 21 with a radial spreading tendency on the lower portion of skirt 19.

The tubular container 11 is preferably of circular section throughout. Its circular upper end opening 35 is only slightly larger than the head 31 so that the latter, without any unnecessary clearance, is freely slidable therein. Below the end opening 35 the insert has an interior annular enlargement 36 which is of appreciably larger diameter than the diameter of head 31. Below the enlargement 36 the insert is interiorly annularly contracted at 37 and provided with threads 38 which are operatively engageable by the threads of the plug portion 24. Below the threads the interior surface of the insert is substantially cylindrical at 39 down to an inwardly tapered seat 40 below which is a flared surface 41. Externally the lower portion of the insert may be provided with progressively enlarging circumferential ribs or fins.

The container or tubular insert 11, as here shown, is embedded in the tip portion of the rubber body 12 to be completely laterally covered thereby, being vulcanized therein during a molding operation. The flared portion 41 of the insert is covered by a molded band 42 of rubber

as a provision against separation of the rubber body from the insert due to internal pressure.

With the assembled core as shown in Figure 4, the spreading tendency of the valve body 30 does not substantially distort the skirt 19. Spring 34 is fairly light and the skirt sufficiently heavy ordinarily to overcome the spreading tendency. To assemble the core with the container it is dropped in the latter and then head 31 is pressed downwardly until recess 32 receives the lugs 27 and 28 whereupon the head may be turned to screw the plug portion 24 to the position shown in Figures 2 and 3. The rib 33 may be engaged by a suitable tool so that the head may be positively rotated. Any other provisions whereby the head may be engaged by a suitable tool may be used as well as any other suitable means whereby rotative movement of the head may be transmitted to the plug portion.

In Figure 2 the core is contemplated as just having been turned to final position in the container. The tapered portion of the rubber body 18 is seated tightly against the shoulder 40, but, as shown, there is a slight clearance between the skirt 19 and the rubber bore portion 42. When the head is now released the spring 34 lifts the valve body 30 into engagement with the seat 21, but not quite to the position shown in Figure 3 and the top surface of the head at the sides of the rib is not quite flush with the top of the insert. The skirt 19 is not appreciably, ordinarily, distorted under the conditions assumed, since the force of the spring is preferably such in relation to the radial yieldability of the skirt that the latter is not appreciably spread. However, when the tube with which the valve stem is associated is filled with air, the valve body 30 is forced upwardly relative to the container 11 so that the parts take the relation shown in Figure 3, the skirt 19 being spread into sealing contact with the rubber bore portion 42. Not only does this assist in preventing air from leaking upwardly between the barrel and container, but it also provides a lap for the joint between the upper end of the band of rubber 42 and the surmounting portion of the insert so that air is most effectively prevented from getting between the lower end of the insert and body 12.

If it is desired to remove the core the head is pressed inwardly into engaging relation with the plug portion and the latter is turned out. The barrel immediately follows the plug portion upwardly due to the swivel connection between the two parts.

As above stated, in the absence of air pressure on the lower end of valve body 30, the skirt will be substantially in the undistorted condition shown in Figures 2 and 4, since it is able to withstand the spreading tendency of the valve body. Even if it should be spread, it will immediately resume its undistorted condition when the core is assembled with the container and will form no obstruction to the insertion of the core due to the fact that the valve body is moved out of the skirt 19 when the head is clutched with the plug portion.

The edge 21 forms an initial line contact with the conical body 30 and this is of importance in securing a proper seal. When the head is in the upper end of the insert as shown in Figure 3, it is positively centered and the axis of the valve body is maintained perpendicular to the plane of the circular edge so that uniform circumferential contact is assured.

When the valve head is in the position shown

in Figure 3, the stem is effectively closed against ingress of foreign matter such as dust and water. In the inflating operation the head is moved by the usual chuck pin to a position in enlargement 36 so that air is enabled to pass the head. The space between the bottom of the valve head and the top of the plug portion lugs is preferably greater than the unseating movement of the head in the inflating operation. Otherwise it would be necessary to provide means for maintaining the groove of the head always in register with the lugs.

The core container need not necessarily be a part of a rubber valve stem but could be constituted by a portion of a metal valve stem, as is obvious.

The arrangement shown in Figures 6 and 8 is substantially the same as that just described, the only material difference being that the plug portion 43 is not swivelled to the barrel 44, but is relatively displaceable axially relative thereto. When this core is assembled with the insert the barrel reaches its seating position by an initial direct rectilinear movement and relative depression of the head brings the latter into engagement with the plug portion which can then be turned to position, forcing the barrel against its seat. Since the plug portion and barrel are not connected together the latter will not follow the former when it is unscrewed and must be pulled out after the plug portion is unscrewed. If it should be required that the spreading tendency of the valve body be immediately relieved at the start of the assembly operation the seat for the lower end of the spring may be placed on the plug portion instead of on the barrel. In such case the plug portion is merely provided with an internal annular ledge of sufficient width to receive the lower end of the spring securely and the spring is made of appropriate length.

The container need not be confined in length to the tip portion of the stem, although it should be if it is desired to provide a stem of the utmost flexibility. In Figure 7 I have shown a container 45 which is of greater length than the container previously described, extending even to the lower extremity of the stem, if desired. Also, in the construction shown in Figure 7, the plug portion 46 and barrel 47 are integrally joined.

The stem body 12 is of rubber or rubber composition designed with particular reference to the requirements of a flexible rubber valve stem and these are not always consistent with the best heat resisting and sealing qualities. The rubber valve portion 18, being separate from the stem body, can emphasize these latter qualities. The term "rubber" as used herein includes any suitable composition of rubber or other materials of similar characteristics.

In the drawings, the stems are shown in upright position and the terms "upper" and "lower" are used herein with reference to that position and merely as a matter of convenience.

Variations from the specific disclosures herein are, of course, possible without departure from the invention and accordingly I do not limit myself as to details of form and arrangement except as in the following claims.

I claim:

1. A valve core comprising a barrel which includes a freely depending flexible rubber skirt portion at its inner end, a valve pin extending freely axially of said barrel, a conical valve body carried by the inner end of said pin and adapted to seat against said skirt portion at the free end

of the latter with a radial spreading tendency thereon, a head on the other end of said pin, a threaded plug portion having an axial opening in which a portion of the pin intermediate said barrel and head is movably received, a compression spring surrounding said pin and bearing at one end against said head so as normally to seat said valve body, said head being spaced from said plug portion when said valve body is seated, and means on said head and plug portion respectively which interlock for the purpose of transmitting rotative movement of the former to the latter when the two are brought together.

2. A valve core comprising a barrel which includes a freely depending flexible rubber skirt portion at its inner end, a valve pin extending freely axially of said barrel, a conical valve body carried by the inner end of said pin and adapted to seat against said skirt portion at the free end of the latter with a radial spreading tendency thereon, a head on the other end of said pin, a threaded plug portion having an axial opening in which a portion of the pin intermediate said barrel and head is movably received, a compression spring surrounding said pin and bearing at one end against said head so as normally to seat said valve body, said spring maintaining said head in spaced relation to said plug portion when said valve body is seated, and means on said head and plug portion respectively which interlock for the purpose of transmitting rotative movement of the former to the latter when the two are brought together.

3. A valve core comprising a barrel which includes a freely depending flexible rubber skirt portion at its inner end, a valve pin extending freely axially of said barrel, a conical valve body carried by the inner end of said pin and adapted to seat against said skirt portion at the free end of the latter with a radial spreading tendency thereon, a head on the other end of said pin, a threaded plug portion having an axial opening in which a portion of the pin intermediate said barrel and head is movably received, a compression spring surrounding said pin and bearing at one end against said head so as normally to seat said valve body, said head being spaced from said plug portion when said valve body is seated, the seating pressure exerted by said spring being insufficient to spread said skirt portion appreciably, and means on said head and plug portion respectively which interlock for the purpose of transmitting rotative movement of the former to the latter when the two are brought together.

4. A valve core comprising a barrel which includes a freely depending flexible rubber skirt portion at its inner end, a valve pin extending freely axially of said barrel, a conical valve body carried by the inner end of said pin and adapted to seat against said skirt portion at the free end of the latter with a radial spreading tendency thereon, a head on the other end of said pin, a threaded plug portion having an axial opening in which a portion of the pin intermediate said barrel and head is movably received, said barrel and plug portion being formed as separate parts, a compression spring surrounding said pin and bearing at one end against said head so as normally to seat said valve body, said head being spaced from said plug portion when said valve body is seated, and means on said head and plug portion respectively which interlock for the purpose of transmitting rotative movement of the former to the latter when the two are brought together.

5. A valve core comprising a barrel which includes a freely depending flexible rubber skirt portion at its inner end, a valve pin extending freely axially of said barrel, a conical valve body carried by the inner end of said pin and adapted to seat against said skirt portion at the free end of the latter with a radial spreading tendency thereon, a head on the other end of said pin, a threaded plug portion having an axial opening in which a portion of the pin intermediate said barrel and head is movably received, said barrel and plug portion being formed as separate parts which are swiveled together, a compression spring surrounding said pin and bearing at one end against said head so as normally to seat said valve body, said head being spaced from said plug portion when said valve body is seated, and means on said head and plug portion respectively which interlock for the purpose of transmitting rotative movement of the former to the latter when the two are brought together.

6. A valve stem comprising a rubber body having a through bore, a core container embedded in said body and lining one end of said bore, a valve core in said container, said core including a barrel which has a flexible rubber skirt portion projecting beyond the inner end of said container to lap the walls of the bore therebeyond, and a conical valve body adapted to seat in the free end of said skirt with a tendency to spread the latter into external sealing contact with said walls.

7. A valve stem comprising a rubber body having a through bore a core container embedded in said body and lining one end of said bore, a valve core in said container, said core including a barrel which has a flexible rubber skirt portion projecting beyond and lapping the joint between the inner end of said container and the contiguous walls of said bore, and a conical valve body adapted to seat in the free end of said skirt portion with a tendency to spread the latter into external sealing contact with said walls.

8. A valve stem including a core container and a core operatively retainable in said container, said core comprising a barrel which includes a depending flexible rubber skirt portion of tubular form at its inner end, said skirt portion having a sharp inner edge at its free end, a valve pin extending freely axially of said barrel, a conical valve body carried by the inner end of said pin and adapted to bear against said edge as a seat with an initial line contact, said valve body being longer than its possible zone of contact with said edge so that its conical surface projects in both directions past the seat in all cooperative relations of said valve body and seat, spring means normally seating said valve body, and a head on the outer end of said pin and substantially filling the outer end portion of said container when said valve body and seat are in cooperative relation, said container being interiorly enlarged inwardly of said outer end portion and the head being freely slidable in said portion and being movable into the container enlargement relative to said barrel.

9. A valve stem comprising a rubber body having a through bore, a tubular core container embedded in said body and lining one end of said bore, the inner end of said container being interiorly annularly overlapped by the body material, a valve core in said container, said core including a barrel which has a flexible rubber skirt portion projecting beyond and overlapping the joint between the first overlap and the core con-

tainer, and a valve body adapted to seat in the free end of said skirt portion with a tendency to spread the latter against the bore portions contiguous to said joint.

- 5 10. A valve stem comprising a rubber body
embedded in said body and lining one end of said
bore, the inner end of said container being in-
10 teriorly annularly overlapped by the body mate-
rial, a valve core in said container, said core in-
cluding a barrel which has a flexible rubber skirt
portion projecting beyond and overlapping the
joint between the first overlap and the core con-
15 tainer, and a valve body adapted to seat in the
free end of said skirt portion with a tendency to
spread the latter against the bore portions con-
tiguous to said joint, the spreading tendency of
said valve body being in proportion to the air
pressure affecting the valve body.

11. A valve stem comprising a rubber body
having a through bore, a tubular core container
embedded in said body and lining one end of
said bore, the inner end of said container being
interiorly annularly overlapped by the body ma- 5
terial, a valve core in said container, said core
including a barrel which has a flexible rubber
skirt portion of circular cross-section project-
ing beyond and overlapping the joint between 10
the first overlap and the core container, said pro-
jecting skirt portion in its natural condition
having an external diameter appreciably less
than the diameter of the bore at said joint, and
a conical valve body cooperating with the free
end of said skirt as a seat and adapted to spread 15
said projecting skirt portion into sealing contact
with the bore portions contiguous to said joint.

HENRY Z. GORA.