

(No Model.)

C. A. ANDERSON.
PUNCHING AND SHEARING MACHINE.

No. 456,211.

Patented July 21, 1891.

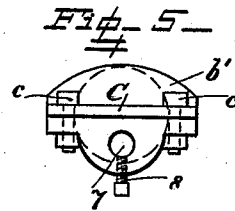
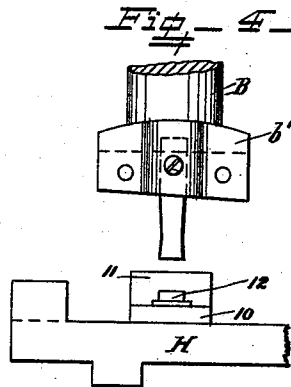
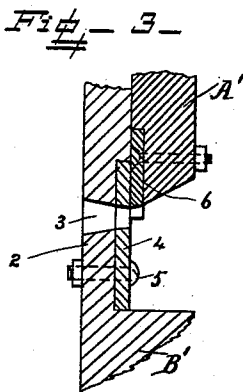
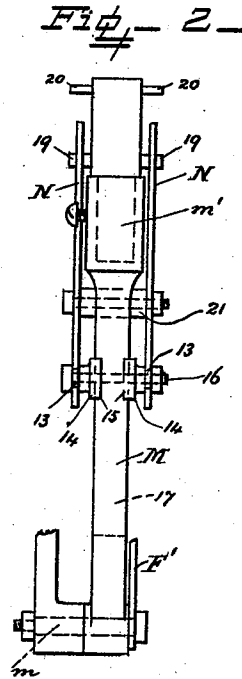
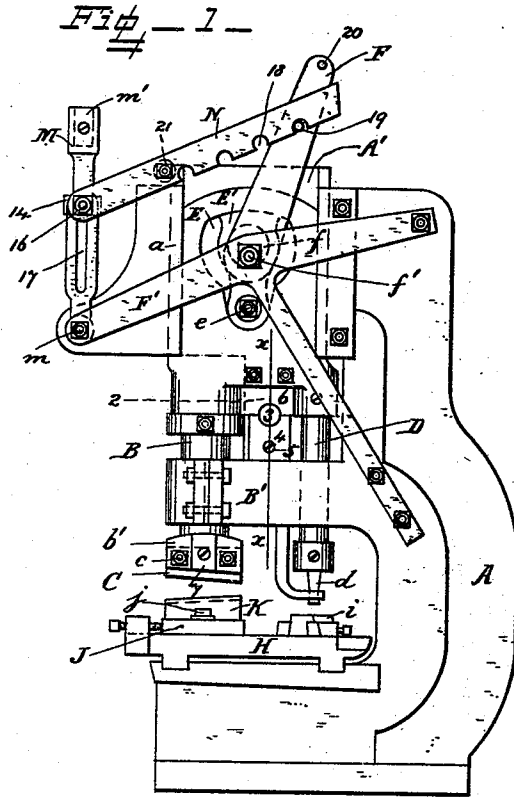

WITNESSES
C. J. Reel
Wm. H. Bates

INVENTOR
C. A. Anderson
by *Herbert W. Jenner*
Attorney

UNITED STATES PATENT OFFICE.

CHARLES ALEXANDER ANDERSON, OF SYMCO, WISCONSIN.

PUNCHING AND SHEARING MACHINE.

SPECIFICATION forming part of Letters Patent No. 456,211, dated July 21, 1891.

Application filed October 22, 1890. Serial No. 368,915. (No model.)

To all whom it may concern:

Be it known that I, CHARLES ALEXANDER ANDERSON, a citizen of the United States, residing at Symco, in the county of Waupaca and State of Wisconsin, have invented certain new and useful Improvements in Punching and Shearing Machines; and I do hereby declare the following to be a full, clear, and exact description of the invention, such as will enable others skilled in the art to which it appertains to make and use the same.

This invention relates to punching and shearing machines; and it consists in the novel construction and combination of the parts hereinafter fully described and claimed, which are improvements upon the machine for which a patent was granted to me on July 12, 1890, No. 432,108.

In the drawings, Figure 1 is a front view of the machine. Fig. 2 is a side view of the operating-levers. Fig. 3 is a detail vertical section through the bar-cutter, taken on the line *x x* in Fig. 1. Fig. 4 is a detail view of the shearing-head adapted to operate a punch, and Fig. 5 is a plan view of a shearing-head from below.

A is the main frame of the machine, and A' is a cross-head sliding in the upper guide *a*.

B is a stem secured in the cross-head and provided with the head *b'* at its lower end, to which head the movable blade C of the shears is attached by bolts *c*. The stem slides up and down in the lower guide B', which forms a portion of the frame of the machine.

D is a stem which carries the punch *d* at its lower end and slides up and down in the said guide B'. The upper end of the stem D is operatively secured to the cross-head A', and the two stems B and D work parallel with each other. The cross-head A' is provided with a cavity E, and E' is an oscillatory plate pivoted on the pin *e* in the lower part of the said cavity.

F is a lever, and *f* is an eccentric projecting from the side of the lever and working in a hole in the plate E'.

F' is an outer frame bolted to the main frame A, and *f'* is a pivot-pin for the said eccentric to turn on, having its ends carried by the said frame.

H is the platen secured to the lower part of

the main frame, and *i* is the die-block secured to the platen under the punch.

J is a plate removably attached to the platen by the bolt *j*, and K is the stationary shear-blade secured to the said plate.

In order that the machine may be adapted to cut bar-iron of round, square, or other section, a web 2, forming a portion of the frame A, is arranged behind the cross-head and is provided with a hole 3. A lower bar-cutter blade 4 is secured against the web 2 by the bolt 5, with its base resting upon the top of the guide B'. An upper bar-cutter blade 6 is secured to the cross-head A' and works up and down in front of the lower blade 4. The bars are inserted through the hole 3 from either side of the machine and are cut off by the blades 4 and 6.

In order to adapt the machine to punch holes in those parts of wide plates which cannot be got under the punch *d*, the shearing-head *b'* is provided with a socket 7 upon one side of it, in which a punch may be inserted and secured by the screw 8. The lower shear-blade and the plate J are removed and the plate 10, provided with the die-block 11, is secured to the platen by the bolt 12 in place of them, as shown in Fig. 4.

A hand-lever M is pivoted on the pin *m* at the front part of the machine, and is provided with a socket *m'*, in which a handle-bar may be inserted, if desired, to increase its length.

N are links for connecting the two levers M and F together. The links N are pivoted upon the bosses 13 of the washer-plates 14, which are provided with curved ends 15, engaging with the sides of the lever M, so that the washer-plates can slide up and down on the lever but cannot turn in either direction. A bolt 16 passes through the washer-plates and the lever and pivotally connects the said links with the lever. A long slot 17 is formed in the lever, in which the pin 16 may be slid up or down to decrease or increase the leverage and adapt it to the work to be performed.

The links N are provided with a series of slots 18 upon their lower edges, and 19 are pins projecting from the lever F for the said slots to engage with. Stop-pins 20 project from the top of the lever F and prevent the

links from being raised clear of the lever, but permit the links to be moved longitudinally to change the engagement of the pins 19 from one pair of slots to another, and thereby to increase the range of action of the punch or shears. A distance-piece 21 is secured to the links between the slots 18 and the pivot-bolt 16, so that the links are kept parallel with each other and are adapted to slide freely upon each side of the lever F.

What I claim is—

1. The combination, with the sliding shearing-head provided with a socket upon one side of it for receiving a punch, and a shear-blade secured direct to the opposite side of the said head from the punch-socket, of the stationary platen and the interchangeable die-block, and the plate having the lower blade secured to it, both the said block and plate being removable and adapted to be secured to the platen under the said shearing-head, substantially as and for the purpose set forth.

2. A sliding shearing-head having a shear-blade secured direct to one side of it, and provided with a socket upon the other side of it for

receiving a punch, substantially as and for the purpose set forth.

3. The combination, with the pivoted hand-lever provided with a longitudinal slot, of the pivot-bolt passing through the said slot, the washer-plates provided with curved ends, and bosses encircling the said bolt, the links pivoted at one end on the said bosses, and the operating-lever pivoted to the other ends of the said links, substantially as and for the purpose set forth.

4. The combination, with the pivoted hand-lever, of the links pivoted at one end to the hand-lever and provided with a series of slots in their lower edges, the distance-piece between the links, and the operating-lever provided with pins adapted to engage with the said slots, substantially as and for the purpose set forth.

In testimony whereof I affix my signature in presence of two witnesses.

CHARLES ALEXANDER ANDERSON.

Witnesses:

C. W. HAMILTON,
M. S. STROUD.