

No. 687,152.

Patented Nov. 19, 1901.

L. GENTY.
INTERNAL COMBUSTION ENGINE.

(Application filed May 28, 1901.)

(No Model.)

3 Sheets—Sheet 1.

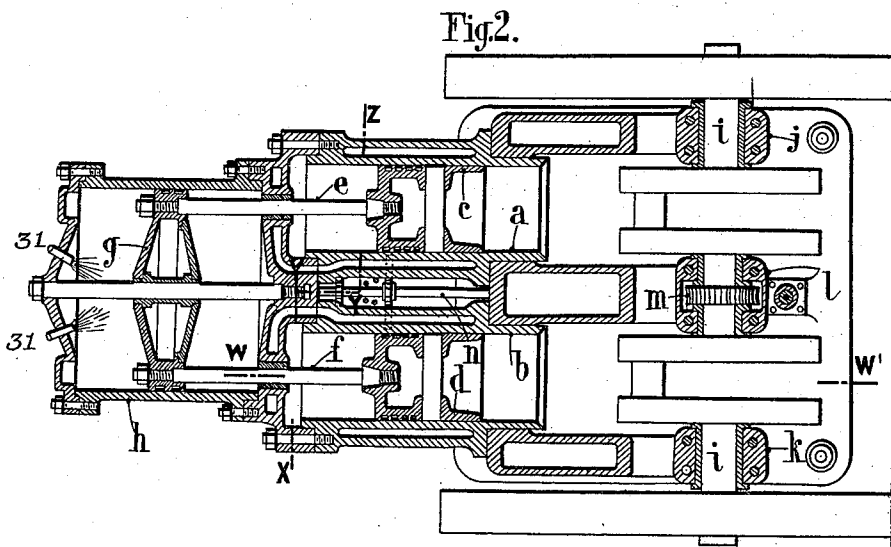
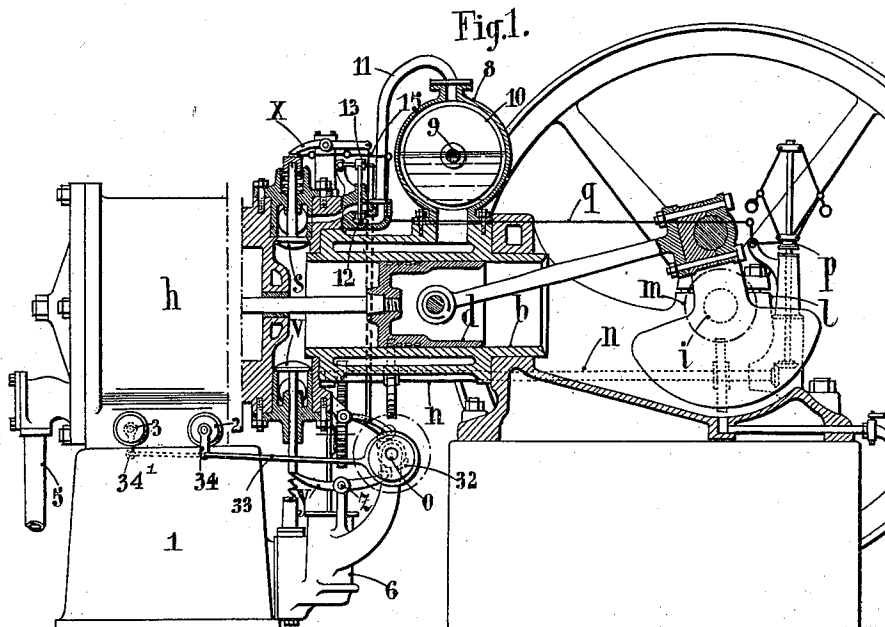

Witnesses:
C. S. Kesler
J. B. Kesler

Inventor
Lucien Genty
By James L. Norris.

Atty

L. GENTY.
INTERNAL COMBUSTION ENGINE.

(Application filed May 28, 1901.)

(No Model.)

3 Sheets—Sheet 2.

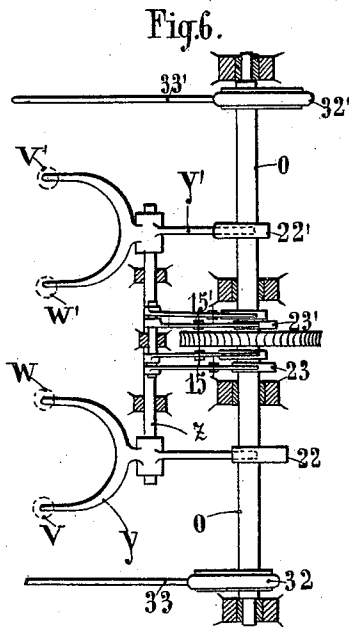
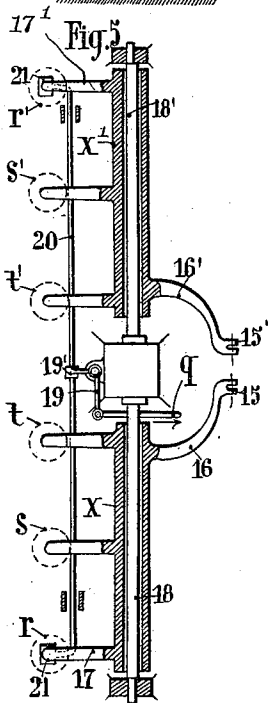
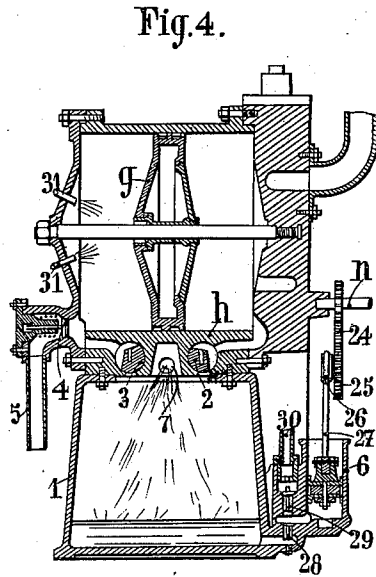
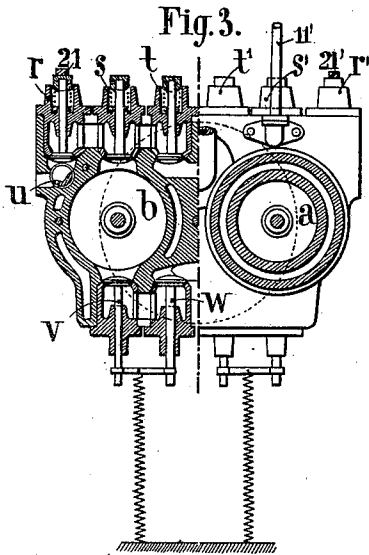

Witnesses
C. S. Kesler
J. B. Kiefer

Inventor
Lucien Genty
 By *James L. Norris*
 Atty

No. 687,152.

Patented Nov. 19, 1901.

L. GENTY.

INTERNAL COMBUSTION ENGINE.

(Application filed May 28, 1901.)

3 Sheets—Sheet 3.

(No Model.)

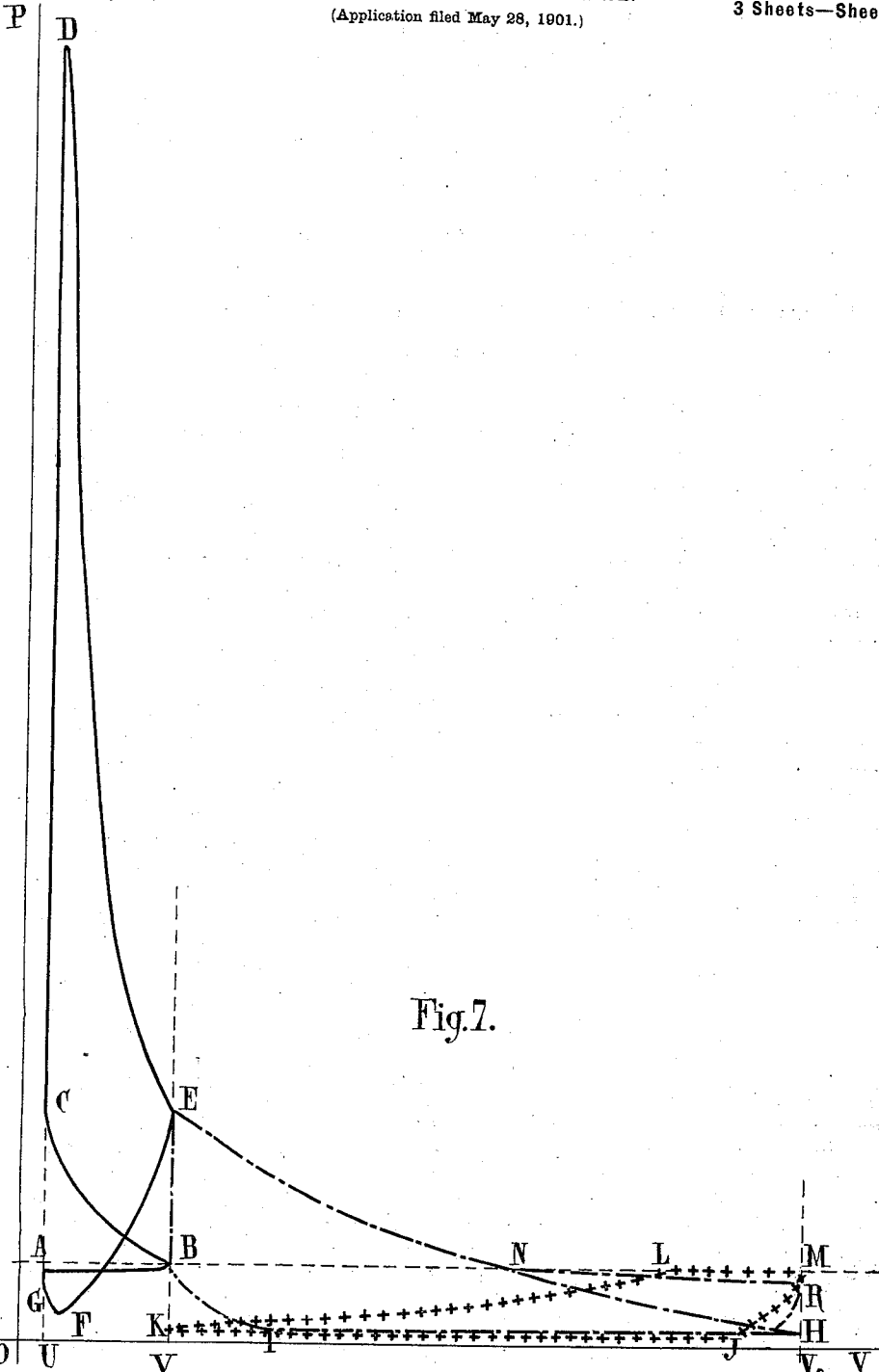

Fig. 7.

Witnesses:
C. S. Kesler
J. B. Keefe

Inventor
Lucien Genty
By James L. Norris
Atty

UNITED STATES PATENT OFFICE.

LUCIEN GENTY, OF MARSEILLES, FRANCE, ASSIGNOR TO HIMSELF, AND LA SOCIÉTÉ GÉNÉRALE DES INDUSTRIES ECONOMIQUES, MOTEURS CHARON, OF PARIS, FRANCE.

INTERNAL-COMBUSTION ENGINE.

SPECIFICATION forming part of Letters Patent No. 687,152, dated November 19, 1901.

Application filed May 28, 1901. Serial No. 62,277. (No model.)

To all whom it may concern:

Be it known that I, LUCIEN GENTY, engineer, a citizen of the French Republic, residing at Marseilles, Bouches-du-Rhône, France, (and having my post-office address 61 Rue St. Jacques, in said city,) have invented certain new and useful Improvements in Internal-Combustion Engines, of which the following is a specification.

10 My invention has for its object to provide an internal-combustion engine working in a new cycle which is arranged so as to utilize in a manner as perfect as possible the heat units generated by the combustion of the gases. I obviate those losses which are incidental to internal-combustion engines as hitherto constructed, the said losses being due to the high pressure which the gases still possess at the end of the stroke and to the waste of the heat units carried away by the hot exhaust-gases and to the heat absorbed by the water circulating in the cylinder-jacket and constituting the greater part of the heat units developed by the combustion of the gases.

15 The amount of heat remaining in the exhaust-gases depends upon the expansion which follows the explosion. It is well known that when the fluid working in the engine has been heated by the combustion of the gases the conversion into work of the heat units evolved by the combustion is the more complete the further the expansion is carried and that this expansion causes a considerable lowering of the temperature of the working fluid.

20 This lowering of the temperature is directly proportional to the ratio of the final volume of the gases to their initial volume. Attempts have been made to increase this ratio of the final volume to the initial volume by compressing the gases to a high degree before explosion and allowing them to afterward expand down to the atmospheric pressure; but such high compression necessitates a very strong engine and tight pistons capable of withstanding these high pressures, which of course increases the cost of the engine and causes it to work under unfavorable conditions.

final volume to the initial volume without exceeding the limits of pressure that are at present reached in internal-combustion engines. I start from a pressure which is the same as that of an ordinary internal-combustion engine and cause the working fluid to expand down to below atmospheric pressure.

For example, let it be supposed that in an internal-combustion engine it is desired to realize the ratio of one hundred to one between the final volume and initial volume. If this were to be obtained in the manner heretofore practiced—say by expanding the gas only until it has reached the atmospheric pressure—it would be necessary to have a very large cylinder in which the expansion could be carried far enough or to increase the compression so that the initial pressure would be at least one hundred atmospheres. According to this present invention it will suffice in order to obtain this ratio of one hundred to one to start from a pressure of twenty atmospheres and to expand until the pressure at the end of the expansion period is equal to one-fifth of an atmosphere, a pressure usually met with in the condensers of steam-engines. I keep thus within normal limits as regards pressure, while causing a considerable lowering of the temperature of the gases during their expansion—that is to say, I realize a considerable transformation into work of the heat units contained in the gases. Increased expansion decreases also the residual or non-utilized pressure which the gases possess at the end of the power-stroke of the usual internal-combustion engines. Attempts have already been made in this direction by lengthening the cylinder, so as to prolong the expansion of the gases, or by causing the gases to do further work in a compound cylinder arranged tandemwise with the first cylinder; but this expansion does not lower the pressure of the gases below that of the atmosphere. An appreciable additional amount of work may be obtained in this manner; but generally speaking it does not justify the increased cost of the engine, and the gases exhausted from the second cylinder are still at a high temperature, so that a considerable number of heat units are lost.

Now the object of this invention is to increase as much as possible the ratio of the

The volume of these exhaust-gases is much greater than that which they would have if they were first brought back to the ordinary temperature and the water-vapor contained in them which arises from the combustion of gases had also first been condensed.

In an engine according to my invention I realize the benefit of the difference between the work required to expel the hot gases charged with vapor and the work which they require to be expelled after they have been cooled and deprived of the water-vapor which they contain.

In internal-combustion engines as hitherto constructed in order to preserve the proper condition of the working parts and effect a proper lubrication and prevent the deterioration of the lubricant it is necessary that the cylinder-walls should be subjected to a powerful cooling, so as to prevent an abnormal rise of the temperature of the said walls. This result is obtained by causing cold water to circulate through a jacket around the cylinders, the explosion-chamber, and the exhaust-valves.

In an engine according to my present invention the heat units abstracted from the walls and lost in the ordinary engines can be utilized in the working of my engine and furnish a surplus of work, while at the same time they insure preservation of the working parts and a thorough clearing of the cylinders at the end of the stroke, it being my object to prevent all the losses that have hitherto been accepted as a necessary evil of the constitution of ordinary gas-engines and to convert into work the greatest possible amount of the heat units produced by the combustion of the gases.

To sum up, in the internal-combustion engines as at present built the cycle of the working fluid is not closed, but is allowed to be completed in the atmosphere without any advantage being taken of the work resulting from this completion, this work being as important as if not more important than the work actually obtained. In my improved internal-combustion engine the cycle is entirely closed, for the working fluid is brought back to the atmospheric pressure and surrounding temperature, while its final state differs from its original one only through the change in its chemical composition, which change has been caused by the combustion of the working fluid.

In order that my invention and the manner in which it can be performed may be well understood, I will describe it, reference being made to the annexed drawings, in which—

Figure 1 is a vertical section through the line *W W'* of Fig. 2. Fig. 2 is a horizontal section through the axis of the cylinders. Fig. 3 is a cross-section through the line *X Y Z* of Fig. 2. Fig. 4 is a longitudinal section of the larger cylinder. Fig. 5 is a plan view of the admission-valve gear. Fig. 6 is a plan view of the general valve-gear arrangement.

Fig. 7 represents the working diagram of the engine.

My improved internal-combustion engine comprises two cylinders *a* and *b*, in which pistons *c* and *d* work on the Otto cycle. The strokes of these pistons take place simultaneously in the same direction; but the cycle in one of these cylinders is two phases behind that of the other. The two pistons *c* and *d* are connected with the crank-shaft and also tandemwise by rods *e* and *f* to the piston *g* of a large cylinder *h*, the internal capacity of which is much larger—for instance, five times—than that of the cylinders *a* and *b*. In this large cylinder *h* the gases burned in the cylinders *a* and *b* complete their expansion instead of being allowed to exhaust into the atmosphere. The crank-shaft *i*, connected with the pistons *c* and *d* by means of links, (not shown in Fig. 2,) revolves in three plumber-blocks, the end ones *j* and *k* of which are of the usual construction, while the intermediate, *l*, is hollow and incloses a worm-wheel *m*, which actuates the valve-gear. This said worm-wheel *m* drives a horizontal shaft *n*, which in its turn drives a second horizontal shaft *o*, parallel to the crank-shaft *i*, and on which are mounted all the cams actuating the valve-gear. Three valves *r s t* (shown in the left-hand part of Fig. 3) are provided for the smaller cylinder *b*. *r* is a gas-inlet valve, *s* a valve for the introduction of the mixture of air and gas into the cylinder, and *t* an air-inlet valve. A similar set of valves *r' s' t'* (shown on the right-hand side of Fig. 3) is provided for the smaller cylinder *a*. The three valves of each set are operated simultaneously from the cams *22 22'* on the shaft *o* by aid of the gearing, of which Fig. 5 is a plan view, the said gearing being formed of vertical rods *15 15'*, bearing at their lower ends on the cams and having their upper ends attached to the arms *16 16'* of sleeves *x x'*, oscillating on stationary shafts *18 18'*, which sleeves are provided with three lever-arms *17 17'*, arranged just above the valves *r s t r' s' t'*, respectively. The shaft *n* also actuates the governor *p*, which is carried by the plumber-block *l*, Figs. 1 and 2, the said governor controlling the gas-inlet valves *r r'*, so that the latter are thrown out of gear as soon as the speed of the engine exceeds a certain limit. For this purpose the rod *q*, connected to the governor, is attached at one end to the bell-crank lever *19*, Fig. 5, the other arm *19'* of which has fixed to it a transverse rod *20*, suitably guided. At each end of the said rod *20* are fixed stops *21 21'*, the position of which is such that they are normally interposed between the rods of the gas-inlet valves *r r'*, respectively, and their corresponding gearing-levers *17 17'*. When the speed of the engine exceeds a certain limit, the rod *q* has been drawn in the direction of the arrow and the rod *20* shifted aside to a sufficient extent to remove two stops *21 21'* from beneath the arms or levers *17 17'*, so that the latter are

without action on the rods of the valves $r r'$. The air-inlet valve t does not exist in the ordinary gas-engines, which only work down to the atmospheric pressure. As my improved
 5 gas-motor works down to a fraction of an atmosphere, it is necessary to so arrange the air-valve t that air does not enter the cylinder when the pressure therein is below that
 10 of the atmosphere, and for this purpose the spring which maintains the said valve applied on its seat should be of a convenient strength. A cock u is provided for regulating the quantity of gas admitted into the cylinder.

15 v and w are two valves which connect the cylinders b with the cylinder h , one of these valves w preventing the gases expanding in the cylinder h and coming from the cylinder a from entering the cylinder b when the pressure in this latter cylinder is less than that
 20 then existing in the cylinder a .

The exhaust-valves v , w , v' , and w' are worked, respectively, from the cams 22 22', keyed on the shaft o by means of the two-
 25 armed levers $y y'$, oscillating on the shaft z , as shown in Fig. 6, 23 23' on the same figure being the cams which operate, respectively, the levers 15 15', acting on the set of valves $r s t r' s' t'$. (Illustrated in Fig. 5.)

30 I provide a condenser 1, fitted with a rotating cock 2, establishing communication between the right-hand side of the piston g and the condenser 1. Another rotating cock 3 establishes a communication between the left-
 35 hand side of the said piston g and the condenser.

4 is a delivery-valve through which the piston g causes exhaust into an external pipe 5
 40 of the cooled gases which have accomplished their cycle. I also provide a pump 6 for withdrawing from the condenser the water accumulating therein resulting both from the condensation of the moisture contained in the
 45 burned gases and from the water injected and atomized by a nozzle 7, opening into the condenser. The piston of the pump 6 is operated from the shaft n by means of gear-wheels 24 25, eccentric 26, fitted on the
 50 wheel 25, and connecting-rod 27, attached to the said piston. 28 is the suction-valve, through which the water contained at the bottom of the condenser is caused to pass toward the body of the pump 6. 29 is a back-
 55 pressure valve, through which the same water is forced toward the pipe 30, leading to the nozzle 7 aforesaid.

Above the small cylinders a and b is arranged a vessel 8, which communicates with the cooling-water in the jacket surrounding
 60 the cylinders. A suitable device maintains the free surface of the cooling-water at the level of the axis 9 of the said vessel, the central part of which is traversed by the said axis or shaft 9. This latter carries a series
 65 of sheet-iron disks 10. These disks and the shaft carrying them are rotated slowly by any suitable gearing connected to the valve-gear

driving-shaft. Tubes 11 11' connect the upper part of the boiling vessel 8 to the boxes containing the admission-valves $s s'$ for the
 70 gaseous mixture. A valve 12, loaded by a weight 13, prevents the steam produced in the vessel 8 from entering the boxes of the valve s until the weight 13 is raised by the
 75 valve-gear. A similar arrangement is provided for the valve s' .

The engine operates as follows: As the piston d in the small cylinder b is beginning its forward stroke the cam 23 has raised the stem 15, which has caused the arms 16 and 17 to
 80 oscillate, so that the three gas and air valves $r s t$ are opened and a mixture of air and gas is drawn into the cylinder b , the said mixture being regulated beforehand by means of the aforesaid cock. When the piston of the cyl-
 85 nder b reaches the end of its forward stroke, said cam 23 releases the stem 15, the three valves $r s t$ close, and the piston d , effecting its return stroke, compresses the mixture to a pressure which depends upon the ratio of
 90 the volume of the cylinder to that of the clearance-space provided at the end of the cylinder. As the piston reaches the end of its return stroke an igniter, such as a heated tube or an electric spark, ignites the mixture,
 95 the pressure rising suddenly in the clearance-space until it reaches its maximum and the piston making its second forward stroke, the gases expanding until the pressure has been reduced to, say, three atmospheres, as in
 100 most of the present gas-engines. At this instant the cam 22, operating the double-armed lever y , causes the exhaust-valves $v w$ to open, which connect the small cylinder b with the
 105 large cylinder h . The piston g , moving together with the piston of the cylinder b in the third return stroke, is acted upon by the fluid which was contained in the small cylinder b , and the final volume of this fluid is represented by the total volume of the larger cyl-
 110 nder, which I have supposed to be equal to five times that of the smaller cylinder. A little before the end of the stroke under consideration the communication between the small and large cylinders is cut off through
 115 the closing of the valves $v w$, the stems of which are released by the double-armed lever y . The gases then go on expanding until the end of the stroke in the cylinder h is reached. When the piston g starts on its
 120 forward return stroke, the rotating cock 2, turned on by the eccentric 32, rod 33, and lever 34, establishes a communication between the cylinder h and the condenser. The piston g on this return stroke causes all the fluid contained in the cylinder h to exhaust
 125 into the condenser. While this stroke is being performed the cock 3 is opened by the eccentric 32', rod 33', and lever 34' to allow the fluid confined in the condenser to be
 130 drawn into the left-hand side of the piston in the large cylinder, so that the volume introduced on the right-hand side of the piston g is exactly compensated for by the volume

drawn in at the left-hand side of the piston in the cylinder, so that the vacuum maintained in the condenser remains unaltered. When the piston g is about to resume its backward stroke, it receives on its right-hand face the exhaust-gases from the cylinder a , which both work alike; but one, as already stated, is two phases behind the other. During this time the gases drawn from the condenser at the left-hand side of the piston of the large cylinder are first compressed and when they reach the atmospheric pressure are expelled through the exhaust-valve 4 and pipe 5. An injection of finely-sprayed water led to the cylinder h through nozzles 31, passing through the cover of the said large cylinder and which may be branched on the pipe 30, prevents the fluid from getting heated during this compression. This water is expelled at the same time as the gases through the exhaust valve and pipe.

The accompanying diagram Fig. 7 illustrates the various phases of the operation, O V and O P being two coördinate axes on which the volumes and pressures are respectively marked. A B represents the suction-stroke of the cylinder b , drawing in the mixture of gas and air. B C is the stroke of compression of this mixture into the clearance-space provided at the end of one small cylinder b . C D is the rise of pressure resulting from the explosion of the mixture. D E shows the expansion-stroke of the burned gases, and E F A is the curve which an indicator mounted on the said cylinder would give for the return stroke of the piston. This line is turned upward at F, because from the point F the communication with the cylinder h has been cut off and the gases remaining in the small cylinder are compressed into the space O U, so as to reach a pressure nearly equal to that of the atmosphere. E H represents the expansion-curve of the gases in the large cylinder. H I is the curve corresponding to the forcing of the gases into the condenser. From the point I the communication with the condenser is cut off and the gases remaining in the right-hand side of the cylinder h are compressed in the clearance-space, so as to attain at the point B a pressure nearly equal to that of the atmosphere. B E is the rise of pressure which takes place suddenly at the time the communication is opened between the cylinder a , wherein the expansion period is just completed, and the cylinder h , which is now starting again its new cycle, with the gases exhausted from the cylinder a . J K is the curve corresponding to the suction of the gases of the condenser by the left-hand side of the piston g . K L is the compression-curve of these gases when the said piston effects its back stroke. At L the pressure attained by this compression is supposed to be equal to the atmospheric pressure, and L M corresponds to the expulsion of the burned gases through the valve 4 and represents a volume which is very nearly equal to the vol-

ume $V' U$ of the small cylinder a . The slight difference between these volumes is due to the fact that the products of combustion have undergone a reduction of volume in consequence of the formation of carbon dioxide and aqueous vapor that has condensed. M J is the curve of the expansion which takes place while the piston g effects its rear stroke and the communication with the condenser has not yet been opened. This expansion has for its purpose to create a partial vacuum before the communication with the condenser is opened. The difference between the area of diagram E H I B for the right-hand face of the piston g and that of diagram J K L M for the left-hand face of the said piston represents the work gained by the expansion and condensation. Despite this gain the heat absorbed by the cylinder-walls would still remain lost.

I will now explain how the steam from a vessel 8 acts in restoring the heat which would otherwise be lost in the cylinder-walls and converting this heat into useful work. The horizontal line representing the atmospheric pressure is reached at about the middle of the stroke of the piston g . (This is due to the ratio of volumes which I have adopted for the various cylinders.) At the same instant the pressure in the cylinder b is also equal to the atmospheric pressure. From this point the pressure of the gases falls below that of the atmosphere. The action of the valve-gear then takes off the weight 13. The vacuum created in the cylinders b and h causes a powerful evaporation in the vessel 8, and the steam formed flows into the pipe 11, lifts the valve 12 therein, and depresses the spring of the valve s , through which it enters the small cylinder b . The air-valve t prevents air at atmospheric pressure from entering into the cylinder b , while the pressure in this cylinder is less than that of the atmosphere.

To avoid the evaporation in the vessel 8 giving rise to tumultuous ebullition owing to the rapid formation of steam caused by the vacuum in the cylinders, disks 10 are employed, they constantly dipping into the water that fills only half of the vessel, and they present while rotating a large and constantly-renewed evaporating-surface without any tumultuous ebullition of the water. The steam comes in contact with the walls of the cylinder b , which it scavenges, and becomes thereby superheated. It goes then through the valve-chambers of the valves $v w$, the large cylinder, and is further superheated by utilizing the heat deposited on the surface of these working parts. It will be seen that I thus recover for the purpose of boiling the water in the vessel all the heat units that have passed through the walls of the small cylinder, and I also collect in the superheated steam the heat of the internal walls of the working parts with which the hot gases have come into contact. The action of steam

has the result that the diagram of the large cylinder instead of following the curve E N H rises above it and follows the nearly horizontal line N R, which is slightly below the atmospheric pressure, but considerably above the portion N H of the aforesaid curve E N H. The area N R H represents the gain obtained by the action of steam. This gain is not counteracted by any corresponding part of the diagram of expulsion of the burned products from the left-hand side of the piston *g* of the large cylinder. As a matter of fact, this supplement of useful work is entirely furnished by steam which will disappear through condensation in the condenser. It will be understood that if the temperature of the water in the said vessel rose above 100° centigrade the line N R would rise above the atmospheric pressure. The normal working temperature of the vessel will be, of course, regulated according to the quantity of heat supplied to the cooling-water by the walls. This diagram shows that I effect the complete utilization of the heat units furnished by the combustion, including those given by the hot gases to the internal walls of the working parts of the engine and that I realize the return of the fluid to its original state. There is a small deviation due to the slight difference between the temperature of the condenser and that of the surroundings; but this deviation can be reduced as much as desired. It should be also noted that the contraction due to the formation of carbon dioxide and the disappearance of the oxygen, which has burned the hydrogen of the combustible gas and has been converted into condensed water, cause the volume L M to be expelled to be smaller than the volume V' U of the fluid introduced into the small cylinder *b*. From this it results that the work required in expelling the gases is reduced, which is advantageous for the efficiency and compensates for the imperfection due to the lowering of temperature caused by the condenser.

Having now particularly described and as-

certained the nature of my invention and in what manner the same may be performed, I declare that what I claim is—

1. In an internal-combustion engine working according to the four-stroke cycle, the combination with two high-pressure cylinders *a b* having small diameters, of a low-pressure cylinder *h* having a larger diameter, a piston *g* in the said cylinder; communications between the high-pressure cylinders and the low-pressure cylinder in which the burned gases are expanded under the atmospheric pressure, a condenser 1 in which the expanded gases at one side of the piston are forced for the purpose of being cooled, a valve 2 for controlling the passage of the gases to the condenser, another valve 3 controlling the passage of the condensed gas to the other side of the piston in the low-pressure cylinder and an exhaust-valve 4 and exhaust-pipe 5 leading these gases into the atmosphere, substantially as described and illustrated in the accompanying drawings.

2. In an internal-combustion engine working according to the four-stroke cycle, the combination with two high-pressure cylinders *a b* having small diameters, of a low-pressure cylinder *h* having a larger diameter, in which the burned gases are expanded on one of the sides of a piston *g* in the said low-pressure cylinder, of a vessel 9 in which the cooling-water of the cylinder-jacket is vaporized rotating disks in the said vessels, a pipe fitted with valves 12 for leading the generated steam through the high-pressure cylinders and afterward to the low-pressure cylinder for the purpose of blowing aft all the burned gases, substantially as described and illustrated in the accompanying drawings.

In testimony whereof I have hereunto set my hand in presence of two subscribing witnesses.

LUCIEN GENTY.

Witnesses:

ALEXANDRE ALTAIRS,
LOUIS ROMAN.