

F. A. MORLEY.

Torch Light.

No. 103,073.

Patented May 17, 1870.

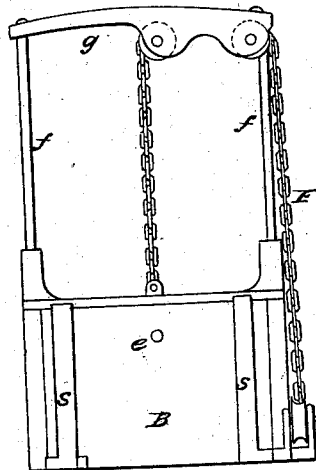
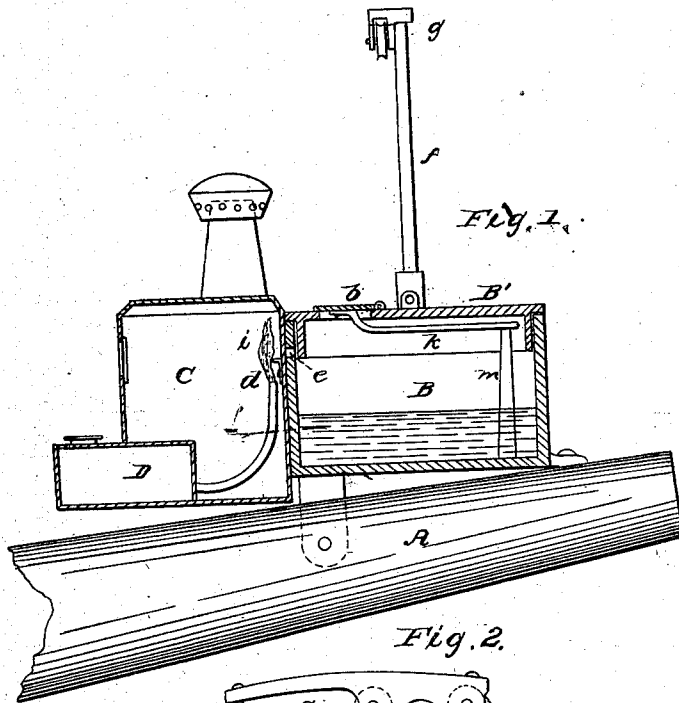

Witnesses:
Wm. G. Dodge
C. E. Warner

Inventor
F. A. Morley

F. A. MORLEY.
Torch Light.

No. 103,073.

Patented May 17, 1870.

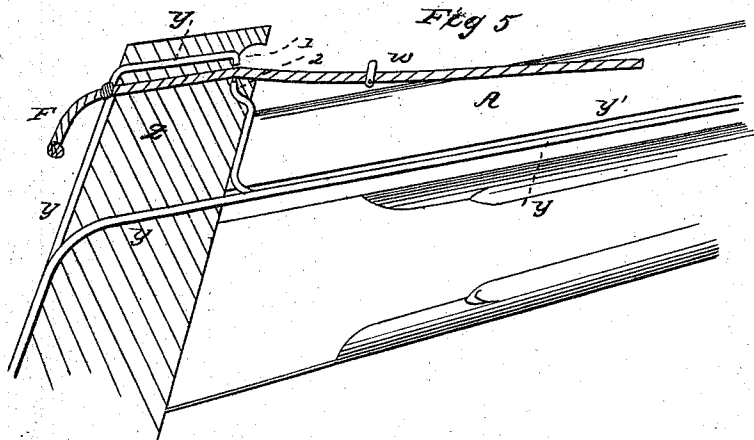
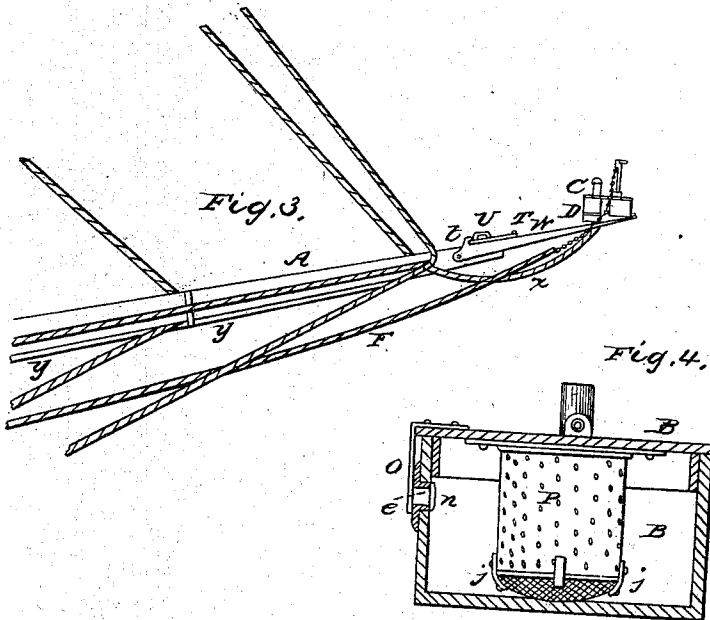

Witnesses
 Wm. Dodge
 C. E. Warner

Inventor:
 F. A. Morley

United States Patent Office.

FRANKLIN A. MORLEY, OF SYRACUSE, NEW YORK.

Letters Patent No. 103,073, dated May 17, 1870; antedated May 2, 1870.

TORCH-LIGHT.

The Schedule referred to in these Letters Patent and making part of the same.

To all whom it may concern :

Be it known that I, FRANKLIN A. MORLEY, of Syracuse, in the county of Onondaga and State of New York, have invented a new and improved Torch-Light; and I do hereby declare that the following is a full, clear, and exact description thereof, which will enable those skilled in the art to make and use the same, reference being had to the accompanying drawings forming part of this specification, in which—

Figure 1 is a sectional view of my invention, and

Figure 2 is a rear view of the torch pot.

Figures 3, 4, and 5 show modifications in the construction of the apparatus and its appendages.

Similar letters of reference indicate like parts in the several figures.

This invention relates to an improved torch or signal-light, chiefly for the use of vessels, to prevent collisions, by transiently making a strong light to show up the position and distance of the vessel, as herein-after more fully explained.

In the accompanying drawings—

A is the jib-boom of a vessel, on the end of which the torch is placed.

B is a torch-pot, containing liquid naphtha or other highly inflammable liquid.

C is a lantern, having an oil-chamber, D, for supplying the flame *d* by means of a wick.

This flame *d* is kept constantly burning, and the parts are so arranged and constructed that when the cover B' of the torch is raised, the flame *d* is sucked through a narrow passage, *e*, into the pot B, and this ignites the vapor of the benzine or naphtha, and thus a large flame is made from the burning naphtha while the said cover B' is raised, and as soon as the cover B' is lowered the signal-flame is extinguished, but as often as the said cover is raised the naphtha takes fire from the concealed lamp *d* D, and the vessel is lighted up.

The cover B' slides vertically on guide-rods *f*, fig. 2, and is raised by a chain or lanyard, F, running over pulleys in the gallows-frame *g*.

The cover is operated by means of the lanyard F, fig. 3, by the lookout stationed on the fore-castle, the operator taking hold of the lanyard at F, fig. 5.

By placing the torch on the end of the jib-boom A, it reflects back onto the hull and sails of the vessel, so that she is shown up well to the opposite or approaching vessel.

The cover B' has a flange on its lower side, which fits within the torch-pot, and makes a sufficient vacuum therein, when raised, to suck the starting flame *d*, through the passage *e*, into the naphtha, and when the cover is down its flange covers the passage *e*, fig. 1, so that the naphtha does not escape by evaporation, and it also prevents the flame *d* from being sucked out by

the vacuum that is formed in B when the torch-flame is extinguished.

In order to prevent the starting flame *d* from being blown out by an explosive ignition of the naphtha, while the cover is but slightly raised, a small ledge or shelf, *i*, fig. 1, is placed immediately over the flame *d*, and this shields the flame *d* very much from the explosive bursts coming, through the passage *e*, from the torch-pot, and to relieve such explosions, the cover has a hinged valve, *b*, which is counterbalanced by an arm, *k*, and the weight of this arm opens the valve *b* as soon as the cover has been lifted, and this valve *b* remains open until the cover is lowered, and when nearly seated, the counterbalance *k* comes in contact with a stud, *m*, and closes said valve *b*.

In raising the cover B', the vacuum in B holds the valve *b* down sufficiently long to draw the flame *d* into B, but if an explosion takes place, the valve *b* rises instantly, the counterbalance *k* assisting the opening of said valve *b*.

A modification of the devices for protecting the lamp *d* D from being blown out by explosion, is shown in fig. 4, which works well, and this consists in a hinged hanging-valve, *n*, which is hung before the passage *e*, so as to hang slightly open, and this allows the flame *d* to be drawn through easily, but the moment an explosion in B takes place the valve *n* is forced to an entirely closed position.

In this modification the valve *n* is placed entirely below the flange of the cover B', so that the valve *n* can swing freely at the first movement of the cover, and to prevent the starting flame *d* from being sucked out by the vacuum formed in B when the torch-flame is extinguished, I provide the cover with a lip, *o*, of thin sheet steel or other metal, which passes down between the torch-pot and lantern, when the cover B' is lowered, and thus closes the passage *e* against the suction before mentioned.

The swinging valve *n* can be placed in a recess deep enough to allow it to swing open, and the flange of the cover B' then cover the passage instead of the lip *o*, but the lip *o* is found to work the most satisfactorily, as it can have a degree of elasticity that will always insure a close covering of the aperture or passage *e*.

To add to the volume of the torch-flame, I also attach a swab, P, fig. 4, to the under side of the cover. The sides of this swab are made of perforated sheet-metal, and the bottom of wire gauze, the said wire bottom being removable, so that the inside of the perforated case P can be filled with cotton or other fibrous material, to absorb naphtha when the cover is down, and give it out to feed the flame when the cover is raised.

The wire gauze that closes the bottom of the swab is attached to a slight ring, and the said ring being

inserted within P, is held in place by thin lugs *j j*, bent under it, and by bending out these lugs the wire bottom is readily detached or removed at any time, for replacing the cotton in the swab when it has become burned by long use.

To obviate the liability of the torch-pot being upset on board of the vessel, and the inflammable naphtha or other liquid being scattered where it might become dangerous by taking fire, the said pot B is attached permanently to the jib-boom, but the lamp C D is made detachable from the torch, so that it can be taken in and trimmed and lighted, and then adjusted to the torch.

The said lamp is trimmed with kerosene or other common oil, and is attached to the torch by hooked slides, which engage with suitable standards *s s*, fig. 2, on the torch-pot; or the torch-pot can be provided with a suitable basket-rack for setting the lamp into, so that the hole in the wall of the lantern shall engage with the passage *e* of the torch-pot.

The starting flame *d* can be fed with naphtha from the torch-pot, by the said pot having a wick-tube projecting from its side, but this would necessitate the taking of the torch-pot on board, to trim and light the starting flame *d*, which would be attended with danger to the vessel, from the inflammable nature of the naphtha, as during the lurching and unsteadiness of the vessel in bad weather it would be liable to be upset, as before mentioned, and would require too much care.

To place the torch out far enough, so as to not set fire to the jib-topsail or outer sail by the flame of the torch, an outrigger, *u*, fig. 3, can be used.

This outrigger is pivoted to the jib-boom end by a pivot, *t*, so that it can be turned up against the stays, when in port, to be out of the way, and it is also made in two parts, held together by a pivot, T, so that by turning the outer portion of the outrigger around on the pivot T, the torch-pot is thrown in, (to the position occupied by the letter *t*), so that the liquid can be placed in the torch readily, and the lamp attached, and said outer portion of the outrigger is then turned back again into the position shown, and locked in this position by a spring catch or bolt, *v*.

The oil-chamber D, in fig. 3, is placed below the lantern C, and separated therefrom by a space of

half an inch, so that the kerosene oil is not heated too much to burn steadily.

The starting flame *d* can be dispensed with, and the torch ignited by electricity.

In fig. 5 *y y'* represent the circuit-wires for heating an igniting wire within the torch-pot.

An open circuit is made by a break in the wires at 1 and 2, and the circuit is closed by a metallic washer or ring, *w*, on the signal-lanyard F, which closes the circuit by bridging the break 1 and 2, when the lanyard is pulled, so that the washer *w* is brought in contact with the wires *y y'*.

In this manner the electricity ignites the naphtha when the cover B' is raised by the lanyard F.

The wires *y y'* are fastened on the under side of the jib-boom, as seen in fig. 3, and are properly insulated with a thin coating of rubber.

When the torch is ignited by electricity, the joint T in the outrigger is dispensed with, and an ordinary horse or foot-rope, *x*, is made use of for supplying naphtha to the torch.

The heated wire or electric spark method of using electricity can be made use of.

By these means a brilliant flash can be shown, to call the attention of approaching vessels, and to show them the exact direction in which the vessel with the torch is steering at once, thus obviating many of the disastrous collisions that are continually occurring on waters where the vessels are numerous.

Having thus described my invention,

What I claim as new, and desire to secure by Letters Patent, is—

1. The starting-light *d*, in combination with the torch B.

2. The self-igniting torch-pot B, attached to the end of the jib-boom, and opened by a lanyard, F, igniting from the concealed light *d* or by electricity.

The above specification of my invention signed by me this 20th day of March, 1869.

F. A. MORLEY.

Witnesses:

WM. J. DODGE,
ALVAH WORSTER,
C. E. WARNER.