

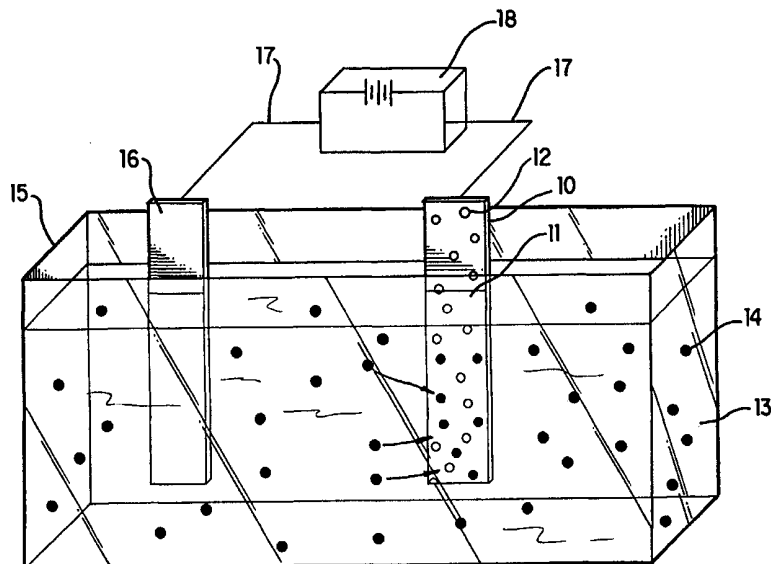

## INTERNATIONAL APPLICATION PUBLISHED UNDER THE PATENT COOPERATION TREATY (PCT)

(51) International Patent Classification <sup>7</sup> : <b>A61F 2/06, A61L 31/00</b>	<b>A1</b>	(11) International Publication Number: <b>WO 00/01322</b> (43) International Publication Date: 13 January 2000 (13.01.00)
<p>(21) International Application Number: PCT/US99/15237</p> <p>(22) International Filing Date: 6 July 1999 (06.07.99)</p> <p>(30) Priority Data: 09/110,697                      7 July 1998 (07.07.98)                      US</p> <p>(71) Applicant: SCHNEIDER (USA) INC. [US/US]; 5905 Nathan Lane, Plymouth, MN 55442 (US).</p> <p>(72) Inventor: DING, Ni; 4365 Juneau Lane, Plymouth, MN 55446 (US).</p> <p>(74) Agents: ABRAMS, Samuel, B. et al.; Pennie &amp; Edmonds LLP, 1155 Avenue of the Americas, New York, NY 10036 (US).</p>	<p>(81) Designated States: CA, JP, European patent (AT, BE, CH, CY, DE, DK, ES, FI, FR, GB, GR, IE, IT, LU, MC, NL, PT, SE).</p> <p><b>Published</b> <i>With international search report.</i></p>	

(54) Title: MEDICAL DEVICE WITH POROUS SURFACE FOR CONTROLLED DRUG RELEASE AND METHOD OF MAKING THE SAME



## (57) Abstract

The medical devices of the invention comprise a portion having a porous surface for release of at least one biologically active agent therefrom. The porous surface is made of a material such as a polymer having a plurality of voids. To load the porous surface with a biologically active agent or drug, an electrophoresis method is employed. In this method, a device having a porous surface is placed into a drug solution or suspension, along with an electrode. An electric current is applied to the device and electrode. Under such a current, the drug, which has a positive or negative charge, will be loaded into the pores or voids of the porous surface.

**FOR THE PURPOSES OF INFORMATION ONLY**

Codes used to identify States party to the PCT on the front pages of pamphlets publishing international applications under the PCT.

<b>AL</b>	Albania	<b>ES</b>	Spain	<b>LS</b>	Lesotho	<b>SI</b>	Slovenia
<b>AM</b>	Armenia	<b>FI</b>	Finland	<b>LT</b>	Lithuania	<b>SK</b>	Slovakia
<b>AT</b>	Austria	<b>FR</b>	France	<b>LU</b>	Luxembourg	<b>SN</b>	Senegal
<b>AU</b>	Australia	<b>GA</b>	Gabon	<b>LV</b>	Latvia	<b>SZ</b>	Swaziland
<b>AZ</b>	Azerbaijan	<b>GB</b>	United Kingdom	<b>MC</b>	Monaco	<b>TD</b>	Chad
<b>BA</b>	Bosnia and Herzegovina	<b>GE</b>	Georgia	<b>MD</b>	Republic of Moldova	<b>TG</b>	Togo
<b>BB</b>	Barbados	<b>GH</b>	Ghana	<b>MG</b>	Madagascar	<b>TJ</b>	Tajikistan
<b>BE</b>	Belgium	<b>GN</b>	Guinea	<b>MK</b>	The former Yugoslav Republic of Macedonia	<b>TM</b>	Turkmenistan
<b>BF</b>	Burkina Faso	<b>GR</b>	Greece	<b>ML</b>	Mali	<b>TR</b>	Turkey
<b>BG</b>	Bulgaria	<b>HU</b>	Hungary	<b>MN</b>	Mongolia	<b>TT</b>	Trinidad and Tobago
<b>BJ</b>	Benin	<b>IE</b>	Ireland	<b>MR</b>	Mauritania	<b>UA</b>	Ukraine
<b>BR</b>	Brazil	<b>IL</b>	Israel	<b>MW</b>	Malawi	<b>UG</b>	Uganda
<b>BY</b>	Belarus	<b>IS</b>	Iceland	<b>MX</b>	Mexico	<b>US</b>	United States of America
<b>CA</b>	Canada	<b>IT</b>	Italy	<b>NE</b>	Niger	<b>UZ</b>	Uzbekistan
<b>CF</b>	Central African Republic	<b>JP</b>	Japan	<b>NL</b>	Netherlands	<b>VN</b>	Viet Nam
<b>CG</b>	Congo	<b>KE</b>	Kenya	<b>NO</b>	Norway	<b>YU</b>	Yugoslavia
<b>CH</b>	Switzerland	<b>KG</b>	Kyrgyzstan	<b>NZ</b>	New Zealand	<b>ZW</b>	Zimbabwe
<b>CI</b>	Côte d'Ivoire	<b>KP</b>	Democratic People's Republic of Korea	<b>PL</b>	Poland		
<b>CM</b>	Cameroon	<b>KR</b>	Republic of Korea	<b>PT</b>	Portugal		
<b>CN</b>	China	<b>KZ</b>	Kazakstan	<b>RO</b>	Romania		
<b>CU</b>	Cuba	<b>LC</b>	Saint Lucia	<b>RU</b>	Russian Federation		
<b>CZ</b>	Czech Republic	<b>LI</b>	Liechtenstein	<b>SD</b>	Sudan		
<b>DE</b>	Germany	<b>LR</b>	Liberia	<b>SE</b>	Sweden		
<b>DK</b>	Denmark			<b>SG</b>	Singapore		
<b>EE</b>	Estonia						

**MEDICAL DEVICE WITH POROUS SURFACE FOR CONTROLLED  
DRUG RELEASE AND METHOD OF MAKING THE SAME**

5

**FIELD OF THE INVENTION**

This invention relates generally to medical devices for delivering a biologically active agent or drug to a desired location within the body of a patient. More particularly, the invention is directed to medical devices having a porous surface comprising a plurality of voids therein. The porous surface is capable of being loaded with a drug, e.g., by infusing or placing the drug into the voids, for release into the body, particularly upon expansion of the portion of the medical device with the porous surface. In one method of loading the porous surface, the drug is concentrated into the voids by electrophoresis.

**BACKGROUND OF THE INVENTION**

For certain diseases which are localized to a particular part of the body, the systemic administration of drugs for the treatment of these diseases is not preferred because of the inefficiencies associated with the indirect delivery of the drugs to the afflicted area. Also, if a drug causes significant side effects, it is generally inappropriate for systemic delivery.

Instead, it is preferred that the drug be directly applied to the diseased tissue. Because such localized delivery to the afflicted area usually requires a relatively small amount of drug, side effects of the drug are reduced. Also, since localized delivery requires smaller amounts of drugs, such delivery is desirable for expensive drugs.

However, such localized delivery of drugs to the walls of lumens, such as blood vessels and ducts, can be problematic since body lumens are generally involved in the transport of body fluids, which tend to carry the drug away from the afflicted area. Thus, there is a need for devices

and methods for the localized delivery of drugs to afflicted tissue, especially body lumens.

Also, if a drug or biologically active agent is biologically derived (e.g., a gene, a protein or a lipid), it usually cannot withstand standard sterilization of the device (e.g., ETO, gamma, or e-beam sterilization, autoclaving). Thus, the number of drugs that can be incorporated into the implantable device is limited. Hence, there is a need for a method for including such drugs into a drug-releasing device.

10 A number of methods for delivering drugs to body lumens or vessels involve the use of catheters having expandable portions, such as a balloon, disposed on the catheter. For instance, U.S. Patent No. 5,304,121 to Sahatjian, PCT application WO 95/03083 to Sahatjian et al. 15 and U.S. Patent 5,120,322 to Davis et al. describe medical devices in which the exterior surface of the device is coated with a swellable hydrogel polymer. A solution of a drug to be delivered to the afflicted tissue is incorporated into the hydrogel. The drug is usually pre-sterilized by such methods 20 as filtration. The drug is held within the matrix of the hydrogel. In the case where the medical device is a balloon catheter, the drug is delivered by inserting the catheter into the body lumen and expanding the coated balloon against the afflicted tissue of the lumen to force the drug from the 25 hydrogel into the tissue.

However, these hydrogel coated devices have certain disadvantages. In particular, because the loading of the drug into the hydrogel is based on diffusion, the amount of drug that can be loaded onto the devices is limited. Thus, 30 there remains a need for a way to load more drug onto implantable devices.

Other methods for making a drug coated implantable device include ones in which a composition of a drug, a polymeric material and a solvent is applied to at least a 35 surface of the device. Such a method is described in co-pending application serial No. 08/633,490, filed June 13, 1996 and published as EP 0 822 788A2 on February 11, 1998.

Also, U.S. Patent No. 5,464,650 to Berg et al. describes drug containing coatings for medical devices.

#### SUMMARY OF THE INVENTION

5           These and other objectives are accomplished by the present invention. To achieve the aforementioned objectives, a medical device and a method for making such device for the localized delivery of biologically active agents to a patient has been invented.

10           The medical devices of the invention comprise a portion which has a porous surface. The porous surface includes the pores and the material between the pores which make up the porous surface. The porous surface is made of a material, such as polymer or a polymer blend, having a  
15 plurality of voids therein. The void space of the coating is preferably greater than about 60% of the volume of the porous surface. The porous surface can be a porous coating covering the surface of the device. The thickness of such a coating can be tailored to meet individual needs for release of at  
20 least one biologically active agent. Alternatively, the porous surface can be a structural part of the device. For example, a stent graft formed of a porous membrane would have a porous surface. A biologically active agent is loaded into the voids for release when the device is implanted.

25           In another embodiment of the invention, the medical device is a stent endoprosthesis having at least a portion which is covered with a polymeric porous surface such as a polymeric coating or material with a plurality of voids therein. A biologically active agent or a drug is placed  
30 into the voids for controlled release when the stent is implanted or inserted into a body lumen.

          In yet another embodiment, the medical device is a stent graft comprising at least one portion which is made of porous graft material, which can, but need not be further  
35 covered with a porous or "sponge" coating. A drug is loaded into the voids to form a drug-coated stent graft.

The devices of the present invention can be prepared by applying a porous coating composition to a surface of the device, e.g., stent or stent graft. The porous coating composition comprises a polymer dissolved in a solvent and an elutable particulate material. After the coating is cured, it is exposed to a solvent, e.g., water, which causes the particulate material to elute from the polymer to form a porous or sponge coating having a plurality of voids therein.

10           The porous surface or coating can be loaded with a drug in an electrophoresis method. In such a method, the drug is dissolved or suspended in a solvent to form a drug solution or suspension. The device and an electrode are placed into the solution or suspension. An electric current  
15 source, e.g., battery, is connected to the device and the electrode. When the current source is switched on, the drug (which has a positive or negative charge) in the solution or suspension will be loaded into the voids of the device's porous surface.

20           Furthermore, prior to placing the device into the drug solution or suspension, the porous surface of the device can already contain materials which do not dissolve in the solution or suspension. Such materials include drugs or radiopaque materials, which permit the device to be visible  
25 during implantation under fluoroscopy.

With certain devices which are formed of porous materials, such as a porous stent graft, such devices can be loaded without first applying a porous coating to the graft. However, a porous coating can be used in conjunction with  
30 this type of device. A device with such a porous surface can be directly loaded in an electrophoresis method as described above.

#### DESCRIPTION OF THE DRAWINGS

35           Figures 1a-1b depict a method of preparing a porous coating for a medical device.

Figure 2 depicts an electrophoresis method for concentrating a biologically active agent into the porous coating or material.

5                   **DESCRIPTION OF THE PREFERRED EMBODIMENTS**

Devices which can be used in this invention include self-expanding stents and balloon expandable stents. Examples of self-expanding stents useful in the present invention are illustrated in U.S. Patent Nos. 4,655,771 and  
10 4,954,126 issued to Wallsten and 5,061,275 issued to Wallsten et al. Examples of appropriate balloon-expandable stents are shown in U.S. Patent No. 4,733,665 issued to Palmaz, U.S. Patent No. 4,800,882 issued to Gianturco and U.S. Patent No. 4,886,062 issued to Wiktor. It will be appreciated that  
15 all references cited herein are incorporated by reference in their entireties, for all purposes.

The expandable stent may be formed from polymeric, metallic, ceramic materials and/or composite materials. However, it is preferred that the stent contain a metallic  
20 material, e.g., stainless steel, nitinol, tantalum. Suitable polymeric materials include without limitation poly-L-lactic acid, polycarbonate and polyethylene terephthalate.

The stent grafts suitable for the present invention include those appropriate for cardiovascular applications,  
25 such as ones described in U.S. Patent No. 4,657,544 to Pinchuk, or urinary applications, such as U.S. Patent No. 4,334,327 to Lyman. Generally, such grafts are made of biocompatible polymeric materials, e.g., polyurethane, silicone, polyethylene terephthalate, teflon, or tissue  
30 engineered autografts or xenografts. As a result, when these polymeric grafts are used in the claimed electrophoresis method of the invention, it is preferable that the graft include some metallic material to conduct the current and facilitate the concentrating of the drug into the porous  
35 surface.

Furthermore, the stent graft can be formed of a porous material having a porous surface, such as a porous

membrane. Examples of such stent grafts and methods for making them are described in U.S. Patent No. 4,657,544 to Pinchuk and U.S. Patent No. 5,758,562 to Thompson. When such porous stent grafts are used in the electrophoresis method, 5 they can, but do not have to be coated with a porous coating before the grafts are loaded with biologically active agents.

Moreover, other implantable medical devices such as blood oxygenator, heart valves and vein valves can be used in the invention. In general, any implantable device that 10 contains some metal portion can be used.

The following is a more detailed description of suitable materials and methods useful in producing the drug loaded coatings or materials of the invention.

The polymer(s) useful for forming the porous 15 coating should be ones that are biostable, biocompatible, particularly during insertion or implantation of the device into the body and avoids irritation to body tissue. Examples of such polymers include without limitation polyurethanes, polyisobutylene and its copolymers, silicones, and 20 polyesters. Other suitable polymers include polyolefins, polyisobutylene, ethylene-alphaolefin copolymers, acrylic polymers and copolymers, vinyl halide polymers and copolymers such as polyvinyl chloride, polyvinyl ethers such as polyvinyl methyl ether, polyvinylidene halides such as 25 polyvinylidene fluoride and polyvinylidene chloride, polyacrylonitrile, polyvinyl ketones, polyvinyl aromatics such as polystyrene, polyvinyl esters such as polyvinyl acetate; copolymers of vinyl monomers, copolymers of vinyl monomers and olefins such as ethylene-methyl methacrylate 30 copolymers, acrylonitrile-styrene copolymers, ABS resins, ethylene-vinyl acetate copolymers, polyamides such as Nylon 66 and polycaprolactone, alkyd resins, polycarbonates, polyoxyethylenes, polyimides, polyethers, epoxy resins, polyurethanes, rayon-triacetate, cellulose, cellulose 35 acetate, cellulose butyrate, cellulose acetate butyrate, cellophane, cellulose nitrate, cellulose propionate, cellulose ethers, carboxymethyl cellulose, collagens,



chitins, polylactic acid, polyglycolic acid, and polylactic acid-polyethylene oxide copolymers.

If the polymer is being applied to a part of the medical device which undergoes mechanical challenges, e.g., expansion and contraction, the polymers are preferably selected from elastomeric polymers such as silicones (e.g., polysiloxanes and substituted polysiloxanes), polyurethanes, thermoplastic elastomers, polyisobutylene and its copolymers ethylene vinyl acetate copolymers, polyolefin elastomers, and EPDM rubbers. The polymer is selected to allow the coating to better adhere to the surface of the expandable portion of the medical device when it is subjected to forces or stress.

Furthermore, although the porous or sponge coating can be formed by using a single type of polymer, various combinations of polymers can be employed. The appropriate mixture of polymers can be coordinated with biologically active agents of interest to produce desired effects when coated on a medical device in accordance with the invention.

The elutable particulate materials which can be incorporated into the polymer include without limitation polyethylene oxide, polyethylene glycol, polyethylene oxide/polypropylene oxide copolymers, polyhydroxyethyl methacrylate, polyvinylpyrrolidone, polyacrylamide and its copolymers, salts, e.g., sodium chloride, sugars, and elutable biologically active agents such as heparin.

The amount of elutable particulate material that is incorporated into the polymer should range from about 10% to 90% by weight of the porous or sponge coating and preferably, from about 30% to 70%. The average particle size of the elutable material can range from 1-100 microns and preferably from about 2 to 15 microns.

The solvent that is used to form the mixture or slurry of polymer and elutable particulate materials include ones which can dissolve the polymer into solution and do not alter or adversely impact the therapeutic properties of the material employed. Examples of useful solvents for silicone

include tetrahydrofuran (THF), chloroform and dichloromethane.

The composition of polymer and elutable particulate material can be applied to a portion of the medical device in a variety of ways. For example, the composition can be spray-coated onto the device or the device can be dipped into the composition. One of skill in the art would be aware of methods for applying the coating to the device. The thickness of the porous coating can range from about 10  $\mu\text{m}$  to 0.5 mm. Preferably, the thickness is about 20  $\mu\text{m}$  to 100  $\mu\text{m}$ .

After the composition is applied to the device, it should be cured to produce a polymer containing the particulate material and to evaporate the solvent. Certain polymers, such as silicone, can be cured at relatively low temperatures, (e.g., room temperature) in what is known as a room temperature vulcanization (RTV) process. More typically, the curing/evaporation process involves higher temperatures so that the coated device is heated in an oven. Typically, the heating occurs at approximately 90°C or higher for approximately 1 to 16 hours when silicone is used. For certain coatings the heating may occur at temperatures as high as 150°C. The time and temperature of heating will of course vary with the particular polymer, drugs, and solvents used. One of skill in the art is aware of the necessary adjustments to these parameters.

To elute the particulate material from the polymer, a solvent is used. The device can be soaked in the solvent to elute the particulate materials. Other methods of eluting the particulate is apparent to those skilled in the art.

The choice of the solvent depends upon the solubility of the elutable particulate material in that solvent. For instance, for water-soluble particulate materials such as heparin, water can be used. For elutable particulate materials which can be dissolved in organic solvents, such organic solvents can be used. Examples of suitable solvents, without limitation, include ethanol, dimethyl sulfoxide, etc.

As shown in Figures 1a-1b, in one method for forming the porous coating 100, a mixture or slurry comprising a polymer 101, an elutable particulate material 102 and a solvent is applied to a portion of the medical device. The device is then exposed to an aqueous or organic solvent to elute the particulate material 102 from the polymer 101 to form a plurality of voids 103 in the polymer 101 (Figure 1b).

Other methods of making a porous coating/membrane are known in the art, such as several phase inversion methods. Examples of these phase inversion methods are: 1) solvent freeze drying; 2) polymer, solvent and non-solvent pore former systems; and 3) thermal processes using a latent solvent. A more detailed description of these methods can be found in R.E. Kesting "Synthetic Polymeric Membranes - A Structural Perspective", JOHN WILEY & SONS, 2D EDITION, which is incorporated herein by reference.

After the porous coating is formed on the device, the medical device can be optionally sterilized. Depending upon the nature of the drug used, sterilization of the device can occur before or after the drug is loaded into the sponge coating. Methods of sterilization are known in the art. For example, the devices can be sterilized by exposure to gamma radiation at 2.5-3.5 Mrad or by exposure to ethylene oxide.

The porous materials or membranes which can be used to form porous stent graft can be made of a polymer. Suitable polymers include polyurethane, silicone, polytetrafluorethylene, polyethylene terephthalate, polyisobutylene and its copolymers, polylactic acid, polyglycolic acid and its copolymers, cellulose and its derivatives. Graft materials can also be biologically derived. For example, collagen, elastin, tissue engineered autografts or xenografts are suitable.

As noted early, it is desirable that the stent graft contain some metallic material to facilitate loading of the coating with a drug by electrophoresis. Such metallic

material can be incorporated by laminating or cladding a metal or an metallic alloy onto the porous graft material.

To load the biologically active agent in the porous surface, an electrophoresis method can be used.

5 Specifically, as described in Figure 2, a graft or other medical device 10 having a porous surface 11 containing voids 12 is placed into a container 15 which holds a solution or a suspension 13 of a drug 14. The drug 14 does not have to be dissolved in a solvent. It can remain as a suspension such  
10 as a slurry.

Also placed in the container 15 is an electrode 16, typically made of metal. The electrode 16 and the device 10 with the porous surface 11 are connected, typically by wires 17 to a current source 18, such as a battery. When the  
15 current source 18 is switched on, at least some of the drug 14, which contains either a positive or negative charge, is loaded into the voids 12, thereby increasing the amount of the drug at the porous surface. In other words, when an electric field is applied to the solution containing the  
20 drug, the charged drug molecules are forced to move toward the electrode with the opposite charge. Depending upon the charge on the drug 14, the device 10 functions as either an anode or cathode. If the drug 14 is negatively charged, e.g., a protein or heparin, the device 10 will function as an  
25 anode. If the drug 14 is positively charged, the device 10 will function as a cathode.

Also, the type of electrode 16, i.e., its material, used will depend upon whether the device 10 functions as an anode or cathode. For example, if the device 10 is an anode,  
30 an electrode 16 which can function as a cathode is used. Persons skilled in the art are aware of how to select suitable electrodes 16.

Furthermore, by adjusting the pH of the drug solution or suspension 13, the mobility of the drug 14 under  
35 the electric current can be varied. Specifically, at different pH levels, the predominant ionic form of the drug 14 will be different. For example, with respect to

amino acids, if the pH of the solution or suspension 13 is low, e.g., acidic, the carboxyl group is un-ionized and the amino group is ionized. When amino acids are placed into a solution or suspension 13 with a high pH level, the carboxyl 5 group is ionized and the amino group is un-ionized. Such changes in the ionic form or charge form of the drug 14 affects its mobility under the electric current.

It should be noted that the porous surface of the device can contain some biologically active agent even before 10 the surface is loaded with the drug 14 according to this method. More specifically, prior to placing the devices into the drug solution or suspension 13 the porous surface may already contain materials, such as particulate materials, that provide desirable properties to the device. These 15 materials should not be soluble or elutable in the solvent forming the drug solution or suspension 13. They can include another biologically active agent or radiopaque materials to allow the device to be visible during implantation under fluoroscopy.

20 As used herein, "biologically active agent" or "drug" refers not only to the molecular or charged form of the biologically active agent or drug but also to formulations containing the same, such as, without limitation, liposomes, emulsions with surfactant and 25 cyclodextrin encapsulations.

Preferably, biologically active agents having an electric charge are used in this invention. However, a neutral or a weakly charged biologically active agent can also be used if it can be converted to a charged moiety. 30 There are a variety of ways for carrying out such a conversion. For instance, one typical method includes forming an emulsion of the drug or drug particle with a surfactant. Examples of surfactants which can be used are, without limitation, fatty acids, phospholipids and sodium 35 cetyl sulfate. In another method, the biologically active agent can be converted to a charged moiety by cyclodextrin encapsulation.

Suitable biologically active agents that can be used in this invention include without limitation glucocorticoids (e.g., dexamethasone, betamethasone), heparin, hirudin, angiopeptin, aspirin, growth factors, 5 oligonucleotides, and, more generally, antiplatelet agents, anti-coagulant agents, antimitotic agents, antioxidants, antimetabolite agents, anti-cancer agents and anti-inflammatory agents could be used. Antiplatelet agents can include drugs such as aspirin. Aspirin is classified as an 10 analgesic, antipyretic, anti-inflammatory and antiplatelet drug. Anticoagulant agents can include drugs such as glycosaminoglycan, protamine, hirudin and tick anticoagulant protein. Glycosaminoglycans include heparin, heparin sulfate, hyaluronic acid, chondroitin, chondroitin sulfate, 15 dermatan sulfate and keratosulfate and their respective derivatives. Antimitotic agents and antimetabolite agents can include drugs such as methotrexate. Antibiotic agents can include penicillin, cefoxitin, and oxacillin. Also, genes or nucleic acids, or portions thereof can be used. 20 Such genes or nucleic acids can first be packaged in liposomes or nanoparticles. Furthermore, collagen synthesis inhibitors, such as tranilast, can be used.

The description contained herein is for purposes of illustration and not for purposes of limitation. Changes and 25 modifications may be made to the embodiments of the description and still be within the scope of the invention. Furthermore, obvious changes, modifications or variations will occur to those skilled in the art. Also, all references cited above are incorporated herein, in their entirety, for 30 all purposes related to this disclosure.

THE CLAIMS

## I CLAIM:

1. A method of making a medical device having at least  
5 a portion for insertion or implantation into the body of a  
patient, wherein the portion has a surface which is adapted  
for exposure to body tissue of the patient and wherein at  
least a part of the surface is a porous surface having a  
plurality of voids therein to release at least one  
10 biologically active agent therefrom, the method comprising  
loading the porous surface with the biologically active agent  
by

- a) forming a solution or suspension of the  
biologically active agent,
- 15 b) placing the device into the solution or  
suspension,
- c) placing an electrode in the solution or  
suspension,
- 20 d) applying an electric current to the device and  
the electrode, and
- e) allowing at least some of the biologically  
active agent to be loaded into the voids.

2. The method of claim 1 wherein the device comprises  
25 at least a metal portion.

3. The method of claim 1 wherein the electrode  
functions as a cathode and the biologically active agent has  
a negative charge.

30

4. The method of claim 1 wherein the electrode  
functions as an anode and the biologically active agent has a  
positive charge.

35 5. The method of claim 1 wherein the device is a  
stent.

6. The method of claim 5 wherein the stent comprises a metallic material.

7. The method of claim 6 wherein the stent is a self-expanding stent.

8. The method of claim 6 wherein the stent is a balloon-expandable stent.

10 9. The method of claim 1 wherein the device is a stent graft.

10. The method of claim 9 wherein the stent graft comprises a metallic material.

15

11. The method of claim 1 wherein the biologically active agent is heparin.

12. The method of claim 1 wherein the biologically active agent is loaded immediately before implantation of the device.

13. The method of claim 1 wherein at least some of the voids contain a particulate material prior to placing the device into the solution or suspension.

14. A method of making a medical device having at least a portion for insertion or implantation into the body of a patient, wherein the portion has a surface which is adapted for exposure to body tissue of the patient and wherein at least a part of the surface is covered with a porous coating having a plurality of voids for release of at least one biologically active agent therefrom, the method comprising:

- 35 a) forming the porous coating on the surface by  
i) applying a composition comprising a polymer and a particulate material to the surface and



- ii) exposing the surface to a solvent to elute the particulate material from the polymer; and
- 5 b) loading the porous coating with the biologically active agent by
- i) forming a solution or suspension of the biologically active agent,
- ii) placing the coated device into the solution or suspension,
- 10 iii) placing an electrode in the solution or suspension,
- iv) applying an electric current to the coated device and the electrode, and
- v) allowing at least some of the
- 15 biologically active agent to be loaded into the voids.

15. The method of claim 14 wherein the device comprises at least a metal portion.

20

16. The method of claim 15 wherein the device is an expandable stent.

17. The method of claim 14 wherein the electrode  
25 functions as a cathode and the biologically active agent has a negative charge.

18. The method of claim 14 wherein the electrode  
functions as an anode and the biologically active agent has a  
30 positive charge.

19. The method of claim 14 wherein the polymer is an elastomer.

35 20. The method of claim 19 wherein the elastomer is selected from the group consisting of silicones, polyurethanes, polyisobutylene and its copolymers,

thermoplastic elastomers, ethylene vinyl acetate copolymers, polyolefin elastomers, and EPDM rubbers.

21. The method of claim 14 wherein the particulate  
5 material is selected from the group consisting of polyethylene oxide, polyethylene glycol, polyethylene oxide/polypropylene oxide copolymers, polyhydroxyethylmethacrylate, polyvinylpyrrolidone, polyacrylamide and its copolymers, salts, sugars and elutable  
10 biologically active agents.

22. The method of claim 14 which further comprises curing the coating after eluting the particulate material and before loading the biologically active agent.

15

23. The method of claim 14 which further comprises curing the coating after it is loaded with the biologically active agent.

20 24. The method of claim 14 wherein at least some of the voids contain a particulate material prior to placing the device into the solution or suspension.

25. A device produced by the method of claim 1.

25

26. A device produced by the method of claim 14.

27. A method of making an expandable metal stent prosthesis having a surface covered with a porous coating  
30 having a plurality of voids therein to release at least one biologically active agent therefrom, the method comprising:

- a) forming the porous coating on the surface by
  - i) applying a composition comprising a polymer and a particulate material to the  
35 surface and

- ii) exposing the surface to a solvent to elute the particulate material from the polymer; and
- 5 b) loading the porous coating with the biologically active agent by
  - i) forming a solution or suspension of the biologically active agent,
  - ii) placing the coated device into the solution or suspension,
  - 10 iii) placing an electrode in the solution or suspension,
  - iv) applying an electric current to the coated device and the electrode, and
  - v) allowing at least some of the
  - 15 biologically active agent to be loaded into the voids.

28. A method of making a stent graft having a porous surface having a plurality of voids therein to release at  
20 least one biologically active agent therefrom, the method comprising loading the porous surface with the biologically active agent by

- a) forming a solution or suspension of the biologically active agent,
- 25 b) placing the device into the solution or suspension,
- c) placing an electrode in the solution or suspension,
- d) applying an electric current to the device and  
30 the electrode, and
- e) allowing at least some of the biologically active agent to be loaded into the voids.

35

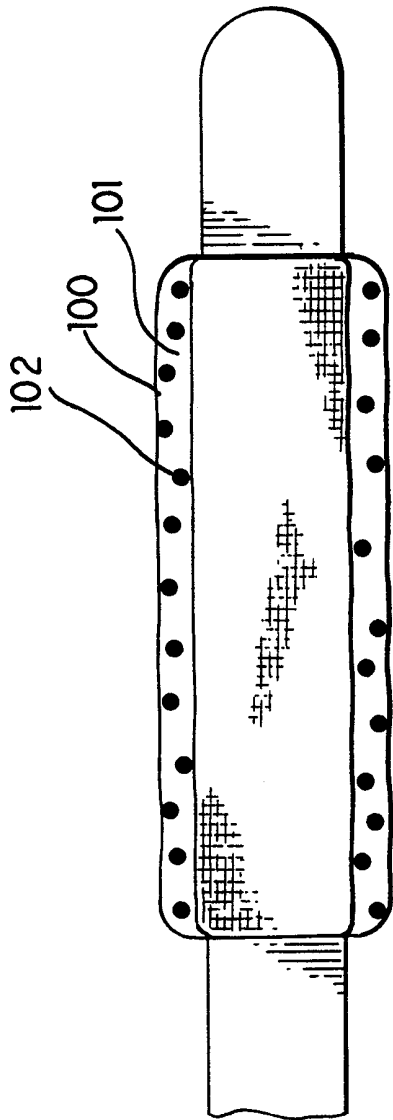

FIG. 1a

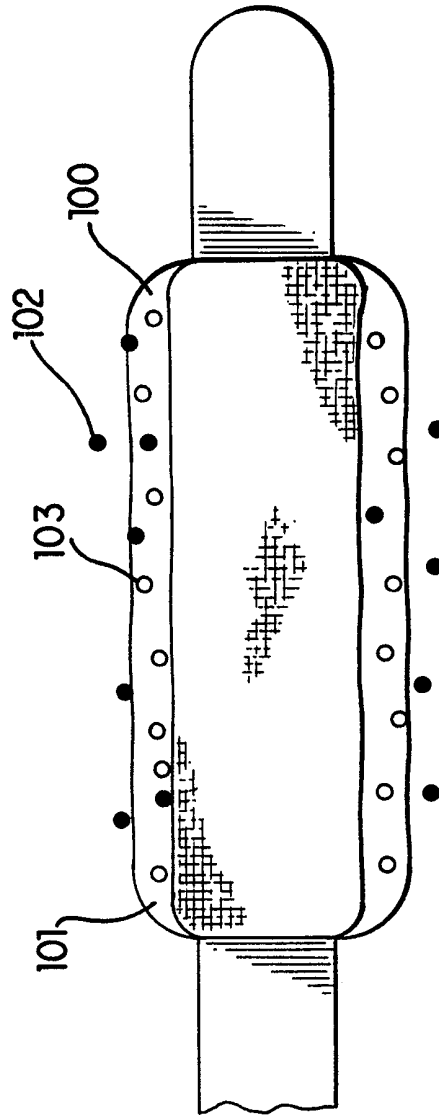

FIG. 1b

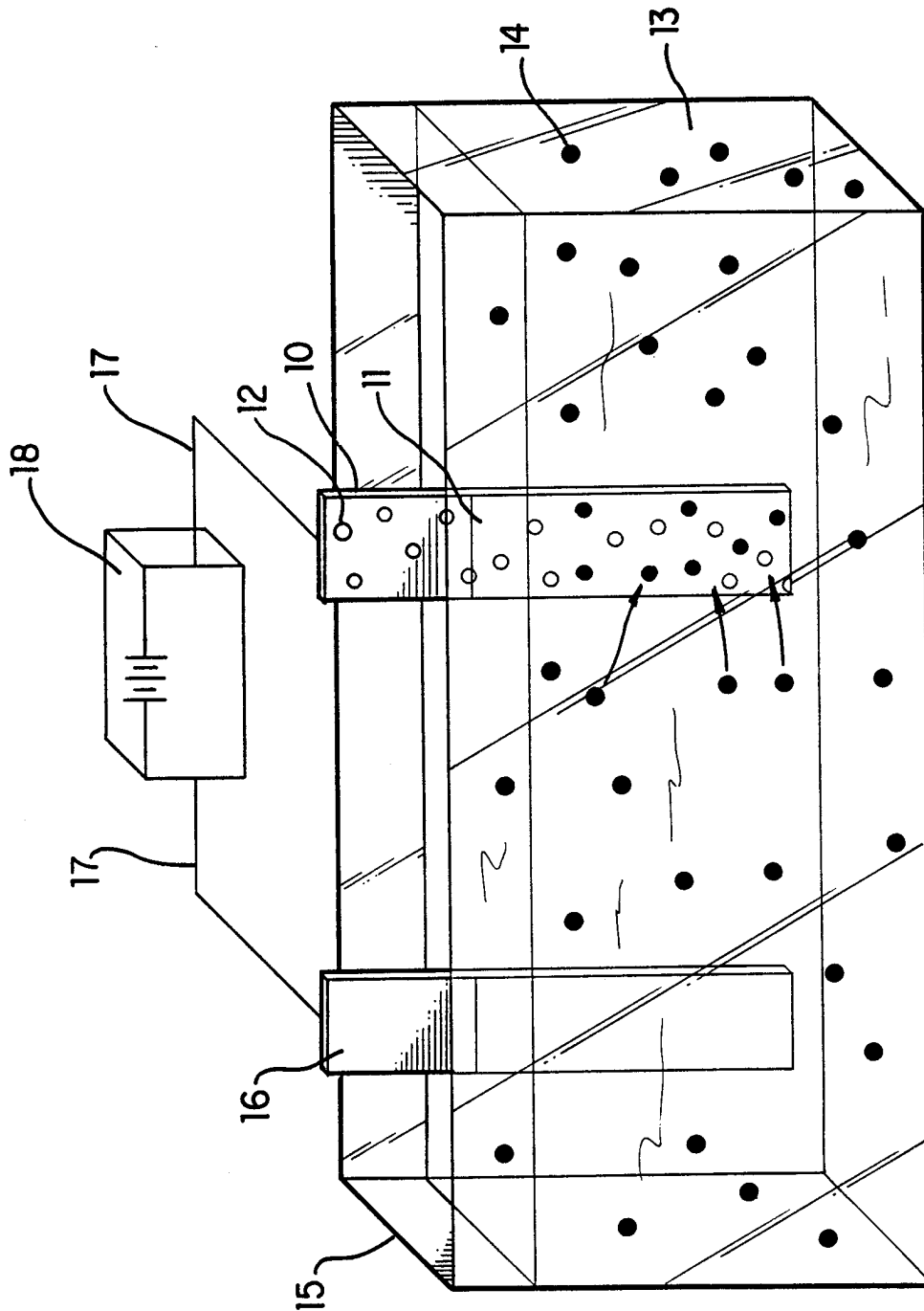

FIG. 2

INTERNATIONAL SEARCH REPORT

International Application No

PC/US 99/15237

A. CLASSIFICATION OF SUBJECT MATTER  
 IPC-7 A61F2/06 A61L31/00

According to International Patent Classification (IPC) or to both national classification and IPC

B. FIELDS SEARCHED

Minimum documentation searched (classification system followed by classification symbols)  
 IPC 7 A61F A61L

Documentation searched other than minimum documentation to the extent that such documents are included in the fields searched

Electronic data base consulted during the international search (name of data base and, where practical, search terms used)

C. DOCUMENTS CONSIDERED TO BE RELEVANT

Category	Citation of document, with indication, where appropriate, of the relevant passages	Relevant to claim No.
A	US 5 607 467 A (FROIX MICHAEL) 4 March 1997 (1997-03-04) column 11, line 1 - line 19 column 12, line 1 - line 14; claims 7,8 ---	1, 14, 27, 28
A	EP 0 747 069 A (COOK INC) 11 December 1996 (1996-12-11) column 21, line 20 - line 30; claims 1,8,14 ---	1, 14, 27, 28
A	US 5 304 121 A (SAHATJIAN RONALD) 19 April 1994 (1994-04-19) cited in the application the whole document ---	1, 14, 27, 28
	-/--	

Further documents are listed in the continuation of box C.

Patent family members are listed in annex.

° Special categories of cited documents :

"A" document defining the general state of the art which is not considered to be of particular relevance

"E" earlier document but published on or after the international filing date

"L" document which may throw doubts on priority claim(s) or which is cited to establish the publication date of another citation or other special reason (as specified)

"O" document referring to an oral disclosure, use, exhibition or other means

"P" document published prior to the international filing date but later than the priority date claimed

"T" later document published after the international filing date or priority date and not in conflict with the application but cited to understand the principle or theory underlying the invention

"X" document of particular relevance; the claimed invention cannot be considered novel or cannot be considered to involve an inventive step when the document is taken alone

"Y" document of particular relevance; the claimed invention cannot be considered to involve an inventive step when the document is combined with one or more other such documents, such combination being obvious to a person skilled in the art.

"&" document member of the same patent family

Date of the actual completion of the international search

15 October 1999

Date of mailing of the international search report

21/10/1999

Name and mailing address of the ISA

European Patent Office, P.B. 5818 Patentlaan 2  
 NL - 2280 HV Rijswijk  
 Tel. (+31-70) 340-2040, Tx. 31 651 epo nl,  
 Fax: (+31-70) 340-3016

Authorized officer

Kanal, P

INTERNATIONAL SEARCH REPORT

International Application No

PCT/US 99/15237

C.(Continuation) DOCUMENTS CONSIDERED TO BE RELEVANT		
Category	Citation of document, with indication, where appropriate, of the relevant passages	Relevant to claim No.
A	<p>US 5 693 085 A (BURMEISTER PAUL H ET AL)                      2 December 1997 (1997-12-02)                      column 5, line 29 - line 61                      column 8, line 38 - line 62; claims                      1,11,12</p> <p style="text-align: center;">-----</p>	<p>1,14,27,                      28</p>

## INTERNATIONAL SEARCH REPORT

Information on patent family members

International Application No

PCT/US 99/15237

Patent document cited in search report		Publication date	Patent family member(s)	Publication date
US 5607467	A	04-03-1997	US 5258020 A US 5163952 A	02-11-1993 17-11-1993
EP 0747069	A	11-12-1996	US 5609629 A AU 5588896 A CA 2178541 A JP 9099056 A WO 9817331 A US 5824049 A US 5873904 A	11-03-1997 19-12-1996 08-12-1996 15-04-1997 30-04-1998 20-10-1998 23-02-1999
US 5304121	A	19-04-1994	CA 2098984 A DE 69131486 D EP 0565604 A EP 0920843 A JP 6503984 T WO 9211896 A US 5674192 A US 5843089 A WO 9211895 A	29-06-1992 02-09-1999 20-10-1993 09-06-1999 12-05-1994 23-07-1992 07-10-1997 01-12-1998 23-07-1992
US 5693085	A	02-12-1997	EP 0754017 A JP 10503663 T WO 9529647 A EP 0746375 A JP 9503945 T WO 9511055 A	22-01-1997 07-04-1998 09-11-1995 11-12-1996 22-04-1997 27-04-1995