

(No Model.)

3 Sheets—Sheet 1.

J. C. WANDS.
AIR BRAKE CONTROLLER.

No. 604,244.

Patented May 17, 1898.

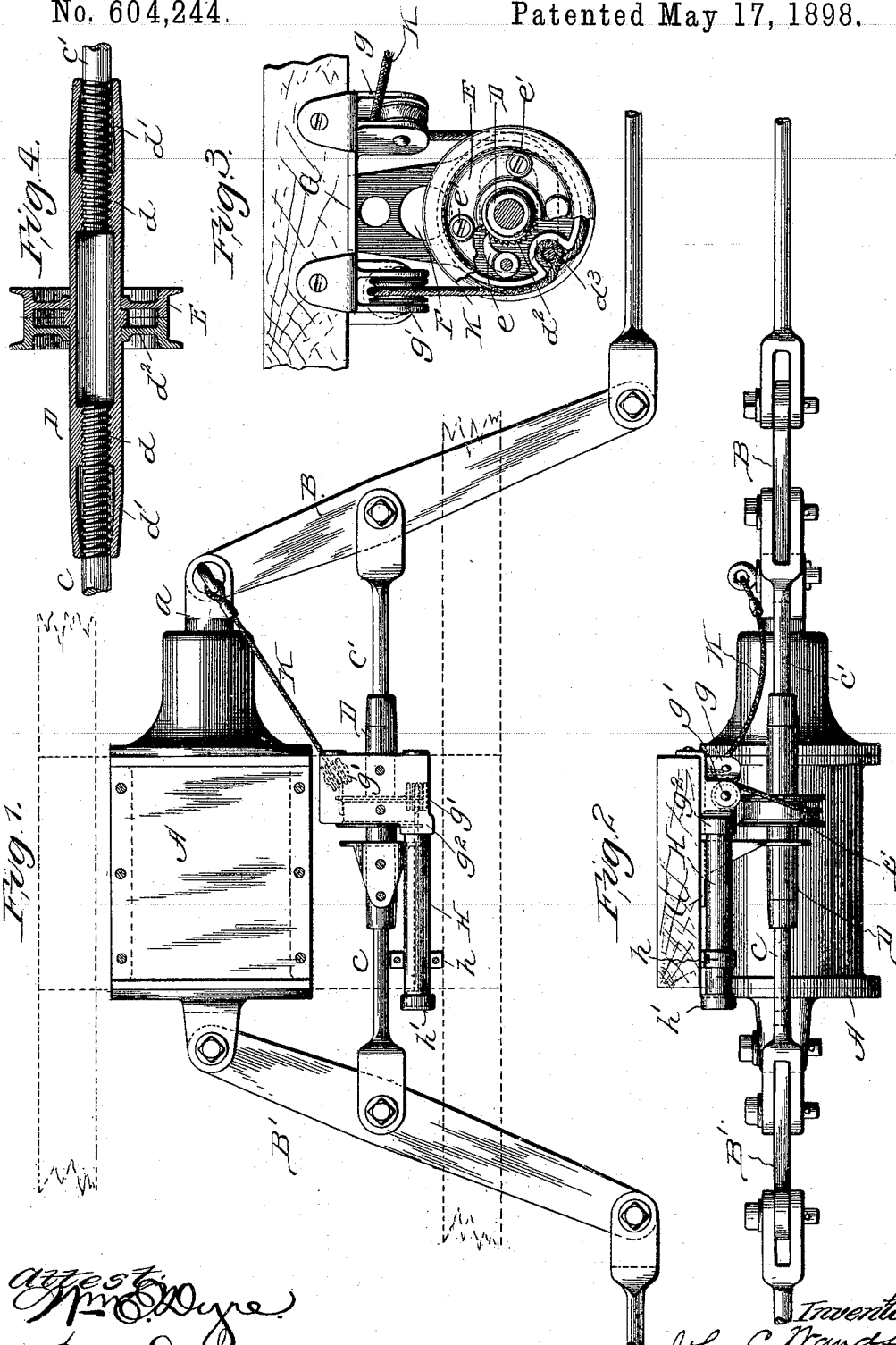

Attest
Wm. O. Dwyer
Ch. Clerk

Inventor
John C Wands
By F. W. Ritter Jr. Atty.

(No Model.)

3 Sheets—Sheet 2.

J. C. WANDS.
AIR BRAKE CONTROLLER.

No. 604,244.

Patented May 17, 1898.

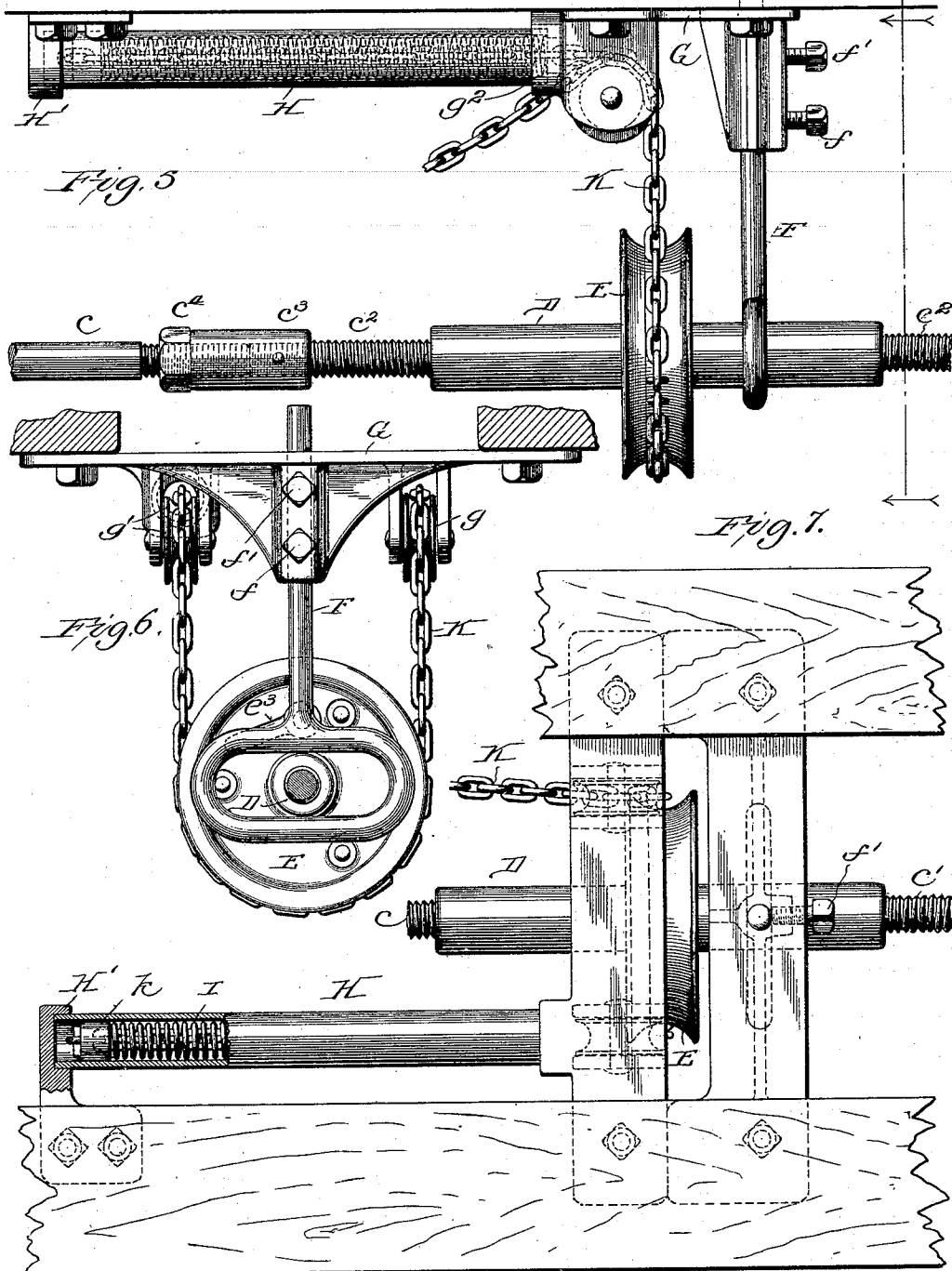

Attest:
Wm. Dye
 Wm. Dye

Inventor:
John C. Wands
 by *J. W. Patton, Jr.*
 Atty.

(No Model.)

3 Sheets—Sheet 3.

J. C. WANDS.
AIR BRAKE CONTROLLER.

No. 604,244.

Patented May 17, 1898.

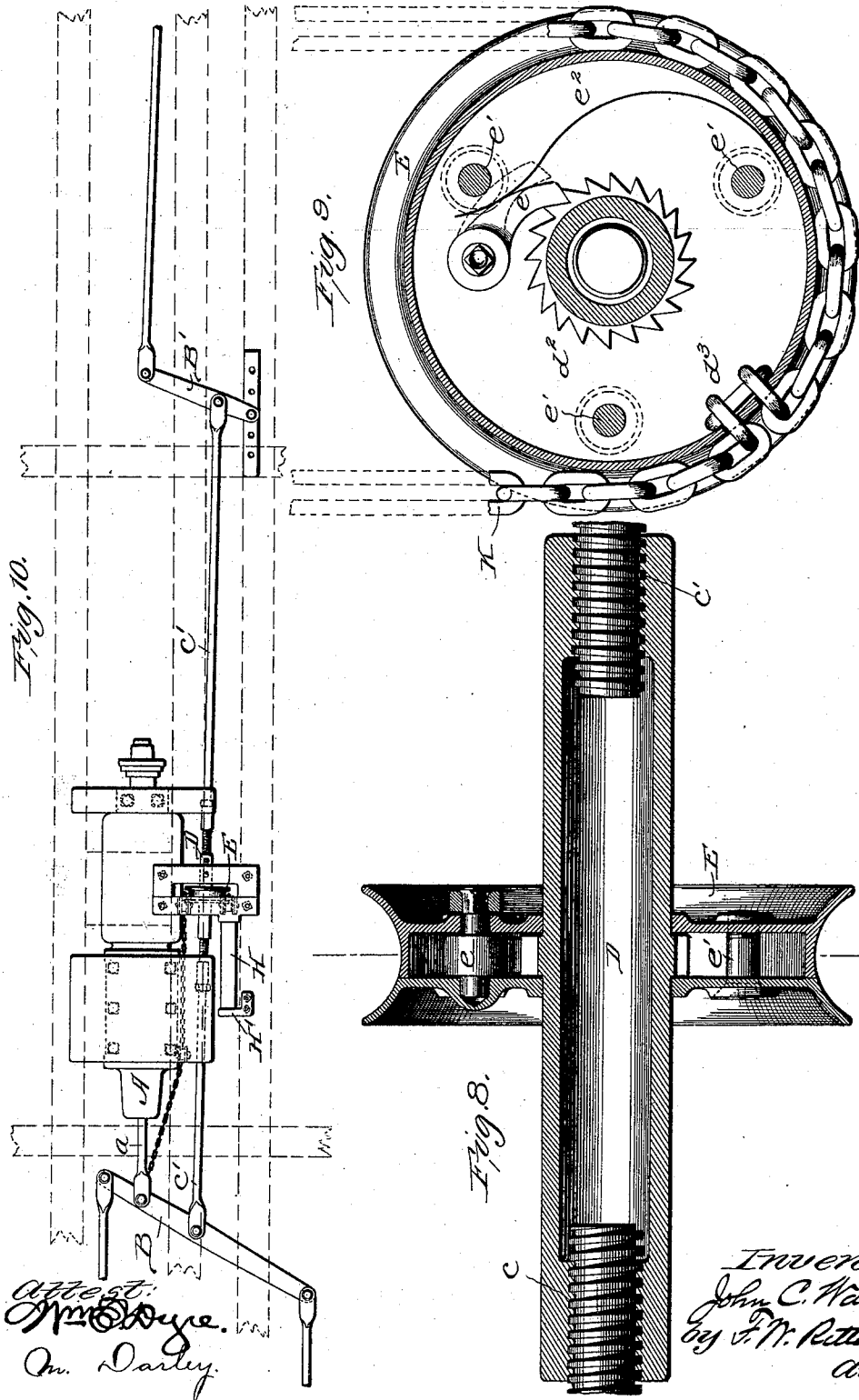

Fig. 10.

Fig. 9.

Fig. 8.

Attest:
Wm. Dwyer
Am. Darby.

Inventor:
John C. Wands
by *J. M. Ritter* for
att'y.

UNITED STATES PATENT OFFICE.

JOHN C. WANDS, OF ST. LOUIS, MISSOURI.

AIR-BRAKE CONTROLLER.

SPECIFICATION forming part of Letters Patent No. 604,244, dated May 17, 1898.

Application filed August 9, 1897. Serial No. 647,566. (No model.)

To all whom it may concern:

Be it known that I, JOHN C. WANDS, a citizen of the United States, residing at St. Louis, in the State of Missouri, have invented certain new and useful Improvements in Air-Brake Controllers; and I hereby declare the following to be a full, clear, and exact description of the same, reference being had to the accompanying drawings, in which—

10 Figure 1 is a plan view of devices embodying my invention shown as applied in connection with an air-brake cylinder and the levers of a passenger-coach-brake rigging. Fig. 2 is a side elevation of the devices shown in plan
5 Fig. 1. Fig. 3 is a view of the turnbuckle-sheave, partly in section, to show the pawl-and-ratchet mechanism of the turnbuckle, the guide-sheaves for the "bridle" rope or chain and the turnbuckle-rest. Fig. 4 is a
15 longitudinal sectional view of the turnbuckle and its sheave. Fig. 5 is an enlarged side elevation of a modified form of the devices applicable to freight-cars. Fig. 6 is a view of the guide-sheaves, turnbuckle-sheave,
20 and turnbuckle-rest as shown in Fig. 5. Fig. 7 is a plan view of the devices as shown in Fig. 5. Fig. 8 is an enlarged longitudinal sectional view of the modified form of turnbuckle and turnbuckle-sheave as applied to
25 freight-cars. Fig. 9 is an enlarged side view of the turnbuckle-sheave and turnbuckle shown in Fig. 8, partly in section, to show the pawl-and-ratchet mechanism by which the turnbuckle is rotated; and Fig. 10 is a
30 plan view of the modified form of the devices shown in Figs. 5 to 9, inclusive, as applied to a freight-car-brake rigging.

Like symbols refer to like parts wherever they occur.

40 My invention relates to the construction of a class of devices which may be properly termed "air-brake controllers," inasmuch as they are intended to adjust or take up the slack in the brake system and thus control
45 the stroke of the air-brake piston, so that there shall be no loss of power or waste of air in applying the brakes either in passenger or freight service.

As is well understood, the effective working stroke of an air-brake piston as commonly constructed is from six (6) to eight (8)
50 inches, more or less, and when the lost mo-

tion in the brake system from wear of the brake-shoes or other cause reaches that amount the brake is ineffective and its efficiency is reduced proportionately for all intermediate degrees of lost motion up to said point. This class of devices as heretofore constructed and denominated "slack-adjusters" have commonly depended upon the excessive travel or movement of some part of the brake system at a point removed from the piston or upon a lever system operated from the piston-rod to actuate the take-up mechanism; but such constructions have proved more or less undesirable, (and sometimes inoperative,) because the intermediate connections would not with certainty transmit and exert the required power to actuate the slack-adjuster mechanism, or because from the nature of their construction they required such a rearrangement of the brake systems in general use as was either expensive, inconvenient, or impossible. To overcome these objections and produce a simple, comparatively inexpensive, and thoroughly efficient means of taking up the slack of the brake system and thus controlling the working stroke of the air-brake piston and one of a character adapted to the systems of brake-rigging in general use are the objects of my present invention.

To this end the main feature of my invention, generally stated, embraces the combination, with the piston-rod of an air-brake and the tie-rod of a brake system, of an interposed turnbuckle and spring-retracted bridle or flexible connection between the piston-rod and turnbuckle, whereby any excessive travel of the piston-rod is communicated to the turnbuckle by the retraction of the bridle and the slack or lost motion is thus eliminated.

There are minor features of invention involving the construction of the turnbuckle, whereby the tie-rod ends are guided into the buckle and the threads thereof relieved from cross-bending strains and protected from dust and dirt, which might interfere with the efficiency of the turnbuckle, and there are other minor features of invention relating to the support of the turnbuckle and the adjustment of said support where required, as in freight-car service, all as will hereinafter more fully appear.

I will now proceed to describe my invention

more fully, so that others skilled in the art to which it appertains may apply the same.

In the drawings, A indicates an air-brake cylinder; *a*, its piston-rod; B B', levers of a brake system or brake-rigging, and C the tie-rod connecting said brake-levers. One of the levers, B, is connected with the piston-rod of the air-brake cylinder, and the other, B', has a fixed point of support, which may be the brake-cylinder, as in the case of passenger equipments, or the car-body, as is the usual case in freight-car equipments.

The tie-rod is composed of two sections *c* and *c'*, threaded right and left at their adjacent ends, where they are coupled up or adjustably connected by a suitable turnbuckle D.

If the turnbuckle D be of the common kind (see Figs. 5 and 8) which may be used with freight equipments, I prefer to form the threaded ends *c*² of the tie-rod sections which enter the turnbuckle D of copper to avoid rust, which might interfere with the free operation of the turnbuckle, and to rivet or otherwise secure the same to tapped sleeves *c*³, by means of which and jam-nuts *c*⁴ they may be securely attached to the tie-rod sections *c c'*. The preferred construction of the turnbuckle D, however, is that shown in Fig. 4 of the drawings, in which the internal threads *d d*, which engage the threaded ends of the tie-rod sections *c c'*, are set back in the buckle far enough to form outer chambers *d'* *d'* or vestibules to the buckle, which inclose or cover the threaded ends of the sections *c c'* and thus protect them from dust and dirt, and the outer portions of the bore are turned to fit the smooth parts of the tie-rod sections, so as to afford bearings therefor, to serve as guides and relieve the threaded ends of the sections from strains arising from the cross or wobbling motion of the tie-rod sections. With such a turnbuckle the threaded portions of the tie-rod sections may, if desired, be cut on stubs and welded to said sections *c c'*, which construction is less expensive and more durable than the threaded copper ends.

Formed on or attached to the periphery of the turnbuckle D is the ratchet-ring *d*², with which engages the pawl or dog *e* of turnbuckle-sheave E.

E indicates the turnbuckle sheave or pulley, which revolves on the turnbuckle and may be composed of separable sections adapted to inclose the pawl or dog *e*, said sections connected by rivets, bolts *e'*, or in other suitable manner. The dog or pawl *e* may be pressed by a spring *e*² (see Fig. 9) or equivalent means provided for maintaining it in engagement with the ratchet-ring *d*² of the turnbuckle, and the journals of pawl *e'* are preferably formed integral with the pawl, one of them being polygonal on its outer or projecting end for the reception of a wrench *e*³, (see Fig. 6,) whereby it may be lifted out of engagement with ratchet-ring *d*² when the turnbuckle D

is to be reversely rotated, as when new brake-shoes are applied to the brake-heads.

In order to steady and support the turnbuckle D, a suspension loop or rest F is provided, which may, if desired, be formed integral with the base-plate G, which carries the bridle sheaves *g g'*. In the case of passenger-car equipment, where the cars are all the same height, this turnbuckle-rest F may be fixed, (see Fig. 3;) but in the case of freight-car equipments, where the height varies from three (3) to five (5) inches, I prefer to construct the turnbuckle-rest F adjustable (see Figs. 5 and 6) by means of set-screws *f f'* or otherwise.

G indicates a base-plate adapted to be secured to the under side or bottom of the car-body, said plate provided with suitable lugs or ears in which are journaled the guide-sheaves *g g'* of the bridle, the sheave *g* nearest the air-brake cylinder being set at such an angle (see Figs. 1 and 2) as will best accommodate the line of draft of the bridle. The base-plate G is also provided with a perforated coupling-boss *g*² for the reception of one end of tubular spring-case H, and said spring-case H may be supported by a clip *h* and have its outer end closed by a suitable clip *h'*, (see Figs. 1 and 2,) or, if preferred, the clip and cap may be formed integral, as at H', Figs. 5 and 7.

K indicates a flexible connection or bridle, preferably one-quarter-inch ($\frac{1}{4}$ " wire cable, (see Figs. 1, 2, and 3,) but which may be a chain (see Figs. 5, 6, 7, and 9) connected at one end with the piston-rod *a* of the air-brake, passing thence through bridle guide-sheave *g* to and around turnbuckle-sheave D, with which it is connected, as at *d*³, and thence through bridle guide-sheave *g'* into the spring-casing H. Within the spring-casing H is confined a coiled or other suitable spring I, having a bearing at the near end against the casing, and through said spring I the bridle K passes and is provided at its free end with an attached block *k*, movable in the spring-casing H, which block constitutes the other bearing of the spring I.

Between the point where bridle K is connected to piston-rod *a* and its point of connection with turnbuckle-sheave D sufficient slack is left to permit of the "normal" or desired travel of the piston-rod without rotation of the turnbuckle-sheave D, and between the point of attachment of said bridle K to the turnbuckle-sheave D and the attachment thereto of block *k* the distance should be such that the retracting-spring I will be substantially at the limit of its expansion.

The controller devices being constructed and combined substantially as hereinbefore pointed out will operate as follows: So long as no slack or lost motion occurs in the system from wear of the brake-shoes or otherwise the piston-rod *a* of the air-brake cylinder will have only its normal or predeter-

mined travel in applying the brakes and the turnbuckle-sheave D will remain quiescent; but as soon as there is any material wear of the brake-shoes or from any other cause any lost motion in the system permits the piston-rod *a* to exceed its normal travel it will draw on the bridle K, which, being attached to turnbuckle-sheave E, will cause the rotation thereof, which rotation will cause the dog or pawl *e* to travel over the ratchet-ring *d*² of the turnbuckle without rotating the turnbuckle, and at the same time the free end of bridle K, which passes through the spring I, inclosed in spring-case H, will, through the medium of block *k*, compress spring I within the case H, whereupon when the piston-rod *a* recedes as the brakes are taken off, the reaction of spring I, acting through the bridle K and pawl *e* on turnbuckle D, will cause the rotation thereof, and thus through the right and left hand threads draw the tie-rod sections *cc'* within the turnbuckle and shorten the tie-rod in proportion to the excess of the travel of the piston-rod, thus eliminating the slack from the brake-rigging system and controlling the next movement of piston-rod *a* or reducing it to its normal travel.

A little grease placed in the cavity of turnbuckle D before the sections *cc'* are inserted will effectually prevent any rusting of the threaded ends of the tie-rod sections.

Having thus described my invention, what I claim, and desire to secure by Letters Patent, is—

1. The combination with the piston-rod of an air-brake cylinder and the tie-rod of a brake system, of a turnbuckle, a turnbuckle-sheave, a flexible bridle which connects the piston-rod and the turnbuckle-sheave and means for actuating the turnbuckle-sheave in a direction the reverse of that caused by the connection with the piston-rod, substantially as and for the purposes specified.

2. The combination with the piston-rod of an air-brake cylinder and the tie-rod of a brake system, of an interposed turnbuckle, turnbuckle-sheave, and a spring-retracted bridle which connects the piston-rod and turnbuckle-sheave, substantially as and for the purposes specified.

3. The combination with the piston-rod of

an air-brake cylinder and the tie-rod of a brake system, of an interposed turnbuckle and turnbuckle-sheave, a bridle which connects the piston-rod and turnbuckle-sheave, and a spring with which the free end of the bridle engages, substantially as and for the purposes specified.

4. The combination with the piston-rod of an air-brake cylinder and the tie-rod of a brake system, of an interposed turnbuckle and turnbuckle-sheave, a spring-retracted bridle which connects the piston-rod and the turnbuckle-sheave, and suitable bridle-sheaves, substantially as and for the purposes specified.

5. The combination with the piston-rod of an air-brake cylinder and the tie-rod of a brake system, of a turnbuckle, a turnbuckle-sheave, a turnbuckle rest or support, means for actuating the turnbuckle-sheave from the piston-rod and means for actuating the turnbuckle-sheave in a direction the reverse of that caused by its connection with the piston-rod, substantially as and for the purposes specified.

6. The combination with the piston-rod of an air-brake cylinder and the tie-rod of a brake system, of a turnbuckle, an adjustable turnbuckle support or rest, means for actuating the turnbuckle from the piston-rod and means for actuating the turnbuckle in a direction the reverse of that caused by its connection with the piston-rod, substantially as and for the purposes specified.

7. In a brake system, the combination with a tie-rod composed of threaded sections, of a turnbuckle having plain guide-chambers in advance of its threaded portion the bores of said chambers turned to afford bearings for the unthreaded portions of the tie-rod, whereby cross or wobbling motion and strain on the tie-rod sections is obviated; substantially as and for the purposes specified.

In testimony whereof I affix my signature, in presence of two witnesses, this 6th day of August, 1897.

JOHN C. WANDS.

Witnesses:

W. R. STOVER,
W. G. KRENNING.