

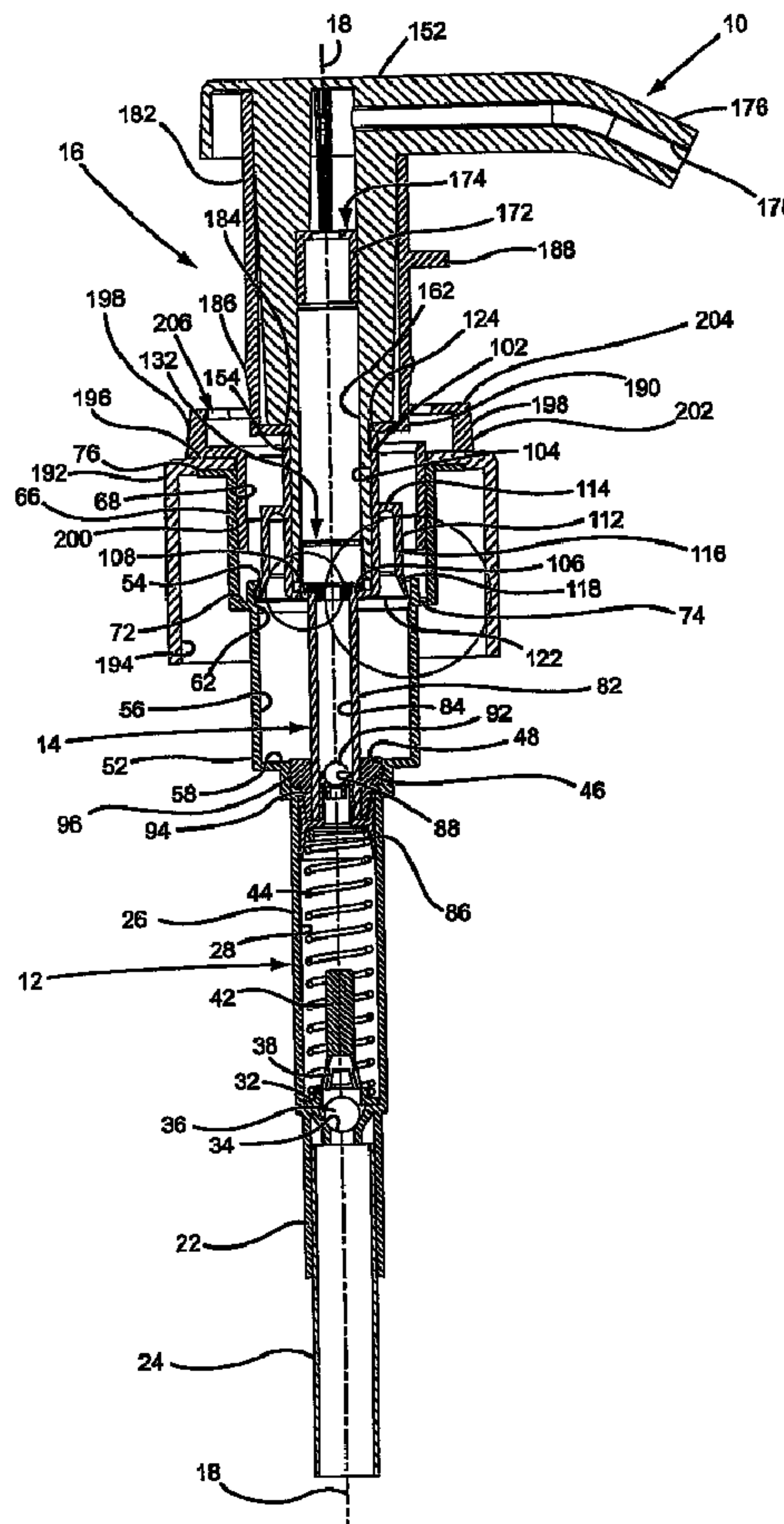

(86) Date de dépôt PCT/PCT Filing Date: 2003/09/05
 (87) Date publication PCT/PCT Publication Date: 2004/05/27
 (45) Date de délivrance/Issue Date: 2010/06/29
 (85) Entrée phase nationale/National Entry: 2005/04/06
 (86) N° demande PCT/PCT Application No.: US 2003/028011
 (87) N° publication PCT/PCT Publication No.: 2004/044534
 (30) Priorité/Priority: 2002/11/06 (US10/288,831)

(51) Cl.Int./Int.Cl. *G01F 11/06* (2006.01),
B05B 11/00 (2006.01), *B05B 7/00* (2006.01)
 (72) Inventeurs/Inventors:
FOSTER, DONALD D., US;
NELSON, PHILIP L., US
 (73) Propriétaire/Owner:
CONTINENTAL AFA DISPENSING COMPANY, US
 (74) Agent: OSLER, HOSKIN & HARCOURT LLP

(54) Titre : **DISTRIBUTEUR DE LIQUIDE MOUSSANT**
 (54) Title: **FOAMING LIQUID DISPENSER**



(57) **Abrégé/Abstract:**

A manually operated liquid foaming dispenser is attached to the top of a container of liquid and is manually vertically reciprocated to dispense the liquid from the container as a foam. The dispenser includes a liquid pump chamber and an air pump chamber that

(57) **Abrégé(suite)/Abstract(continued):**

respectively pump liquid and air under pressure to a discharge passage of the pump where the liquid and air are mixed, generating the foam dispensed from the dispenser. The air pump chamber has a tube valve controlling the discharge of air from the air pump to the discharge passage, and the air pump chamber is charged with air by opening the air pump chamber to the exterior environment of the dispenser.

(12) INTERNATIONAL APPLICATION PUBLISHED UNDER THE PATENT COOPERATION TREATY (PCT)

(19) World Intellectual Property
Organization
International Bureau



(43) International Publication Date
27 May 2004 (27.05.2004)

PCT

(10) International Publication Number
WO 2004/044534 A1

- (51) International Patent Classification⁷: **G01F 11/06**
- (72) Inventors: **FOSTER, Donald, D.**; 14 Upper Dardenne, St. Charles, MO 63304 (US). **NELSON, Philip, L.**; #9 Kingstowne Est. Ct., Wildwood, MO 63011 (US).
- (21) International Application Number:
PCT/US2003/028011
- (74) Agent: **ROLNICKI, Joseph, M.**; Thompson Coburn LLP, One US Bank Plaza, St. Louis, MO 63101 (US).
- (22) International Filing Date:
5 September 2003 (05.09.2003)
- (81) Designated States (*national*): CA, CN, JP.
- (25) Filing Language: English
- (84) Designated States (*regional*): European patent (AT, BE, BG, CH, CY, CZ, DE, DK, EE, ES, FI, FR, GB, GR, HU, IE, IT, LU, MC, NL, PT, RO, SE, SI, SK, TR).
- (26) Publication Language: English
- (30) Priority Data:
10/288,831 6 November 2002 (06.11.2002) US
- Published:**
— with international search report
— before the expiration of the time limit for amending the claims and to be republished in the event of receipt of amendments
- (71) Applicant: **CONTINENTAL AFA DISPENSING COMPANY** [US/US]; 27 Guenther Boulevard, St. Peters, MO 63376 (US).

[Continued on next page]

(54) Title: FOAMING LIQUID DISPENSER

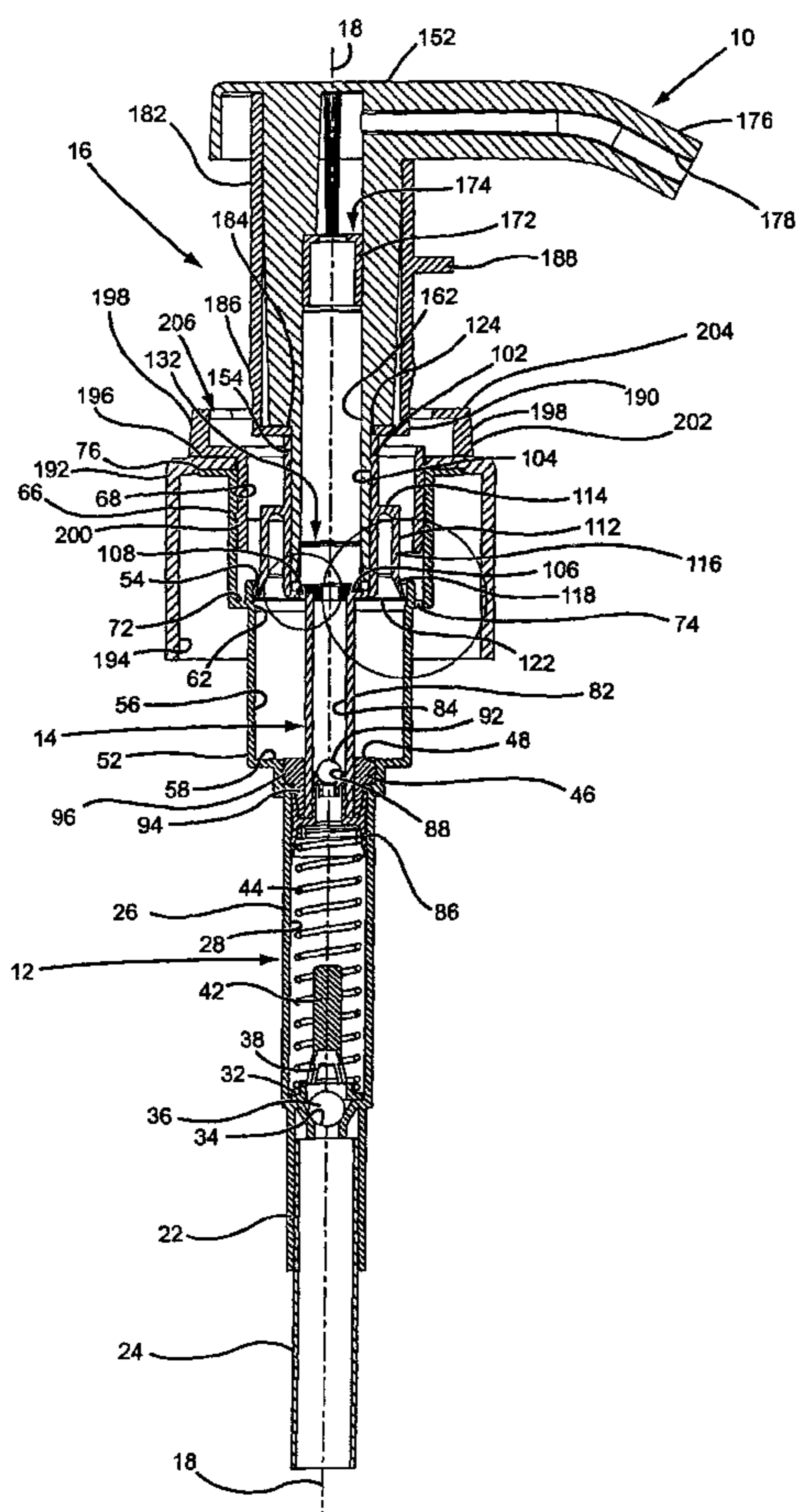

(57) Abstract: A manually operated liquid foaming dispenser is attached to the top of a container of liquid and is manually vertically reciprocated to dispense the liquid from the container as a foam. The dispenser includes a liquid pump chamber and an air pump chamber that respectively pump liquid and air under pressure to a discharge passage of the pump where the liquid and air are mixed, generating the foam dispensed from the dispenser. The air pump chamber has a tube valve controlling the discharge of air from the air pump to the discharge passage, and the air pump chamber is charged with air by opening the air pump chamber to the exterior environment of the dispenser.

WO 2004/044534 A1

WO 2004/044534 A1



For two-letter codes and other abbreviations, refer to the "Guidance Notes on Codes and Abbreviations" appearing at the beginning of each regular issue of the PCT Gazette.

FOAMING LIQUID DISPENSER

Background of the Invention

(1) Field of the Invention

The present invention pertains to a manually operated liquid foaming dispenser. Specifically, the invention pertains to a manually operated pump that is attached to the top of a bottle of liquid and is manually vertically reciprocated to dispense the liquid from the container as a foam. The pump includes a liquid pump chamber and an air pump chamber that respectively pump liquid and air under pressure to a discharge passage of the pump where the liquid and air are mixed, generating the foam dispensed from the pump.

(2) Field of the Invention

Manually operated liquid dispensers that dispense liquid as a foam are known in the prior art. The most well known of these types of dispensers are manually operated trigger sprayers that pump liquid from a bottle container attached to the trigger sprayer and dispense the liquid as a foam that is discharged from the trigger sprayer. The dispensing nozzle of this type of trigger sprayer typically discharges the liquid as a spray toward an obstruction that is vented to the atmosphere. The spray hitting the obstruction mixes the liquid spray with the air of the atmosphere producing the foam that is discharged from the trigger sprayer.

The typical trigger sprayer that discharges a foam is constructed of a sprayer housing containing a pump chamber, a liquid supply passage, and a liquid discharge passage. The liquid supply passage communicates the pump chamber with the liquid contained in the container attached to the trigger sprayer. A pump piston is mounted in the pump chamber
5 for reciprocating movement between charge and discharge positions. A trigger is attached to the sprayer housing and is connected to the pump piston for moving the pump piston. The pump chamber also communicates with the liquid discharge passage which extends from the pump chamber to the discharge nozzle of the trigger sprayer.

A first check valve assembly is positioned between the pump chamber and the liquid
10 supply passage. The first check valve allows liquid to travel through a dip tube and the liquid supply passage into the pump chamber when the pump piston is moved to the charge position, and prevents the reverse flow of liquid from the pump chamber when the pump piston is moved to the discharge position. A second check valve is usually positioned in the discharge passage between the pump chamber and the discharge nozzle. The additional
15 check valve assembly allows the flow of liquid from the pump chamber through the discharge passage to the discharge nozzle when the pump piston is moved to the discharge position, but prevents the reverse flow of liquid and/or air when the pump piston is moved to the charge position.

The basic construction of the foaming liquid trigger sprayer described above is well
20 suited for dispensing liquids where the desired foaming of the liquid is marginal, for example in dispensing foaming liquid kitchen cleaners or bathroom cleaners. However, the foaming trigger sprayers cannot produce a more dense foam such as that of shaving cream.

To produce a more dense foam such as that of shaving cream from a liquid dispenser requires that both the liquid and air being mixed by the dispenser be under pressure. This
25 requires that the manually operated foaming dispenser include both a liquid pump chamber and an air pump chamber. The addition of the air pump chamber to the manually operated

dispenser increases the number of component parts of the dispenser. The air pump chamber must also have an air pump piston that moves between the charge and discharge positions in the air pump chamber to draw air into the chamber and force air under pressure from the chamber. In addition, the air pump chamber must also have a check
5 valve assembly that allows the air of the exterior environment of the dispenser to flow into the air pump chamber when the air pump piston is moved to the charge position and prevents the flow of air from the air pump chamber to the exterior environment when the air pump piston is moved to the discharge position. A second check valve assembly is also needed to control the flow of pressurized air from the air pump chamber to the discharge
10 passage when the air pump piston is moved to the discharge position, and to prevent the reverse flow of air from the discharge passage to the air pump chamber when the air pump piston is moved to the charge position. These additional component parts required by this type of liquid foaming dispenser significantly increase manufacturing costs.

15 Summary of the Invention

The liquid foaming dispenser of the invention overcomes disadvantages of prior art foaming dispensers having both a liquid pump chamber and an air pump chamber by reducing the number of component parts required by the air pump chamber. The liquid foaming dispenser is basically comprised of a pump housing comprising the liquid pump
20 chamber at the bottom of the housing and a coaxial air pump chamber above the liquid pump chamber. The air pump chamber is open at its top. A container cap is provided at the top of the pump housing. A dip tube extends downwardly from the liquid pump chamber at the bottom of the pump housing. With the container cap attached to a container of liquid, the dip tube extends downwardly into the liquid.

25 A pump plunger is assembled into the pump housing from the top of the housing. The pump plunger has a liquid pump piston at its bottom that is inserted through the

pump housing into the liquid pump chamber. A spring is positioned between the bottom of the liquid pump chamber and the liquid pump piston. An air pump piston is also provided on the pump plunger just above the liquid pump piston. The air pump piston is positioned in the air pump chamber with the liquid pump piston positioned in the liquid pump
5 chamber. A dispenser head is provided at the top of the pump plunger. A liquid discharge passage extends through the center of the pump plunger from the liquid pump piston to the dispenser head. A liquid mixer or screen is positioned in the liquid discharge passage in the dispenser head.

In addition, three check valves are positioned along the length of the liquid discharge
10 passage in the pump plunger. One check valve controls the flow of liquid into the liquid pump chamber and prevents the reverse flow. The second check valve controls the flow of liquid from the liquid pump chamber to the discharge passage and prevents the reverse flow. The third check valve controls the flow of air from the air pump chamber to the discharge
15 passage and prevents the reverse flow. The third check valve that controls the flow of air out of the pump chamber into the discharge passage and prevents the reverse flow of air from the discharge passage into the pump chamber is a resilient tube valve. The tube valve engages against the interior surface of the liquid discharge passage. Valve openings in the pump plunger communicate the exterior surface of the tube valve with the interior of the air
20 pump chamber. The novel construction of the tube valve permits the flow of air under pressure from the air pump chamber to the discharge passage and prevents the reverse flow of air from the discharge passage to the air pump chamber. The tube valve is the only valve that controls the flow of air into and out of the air pump chamber, eliminating the additional valve present in prior art foaming dispensers that mix liquid and air under
25 pressure.

The air pump chamber of the invention has a cylindrical interior surface with a first,
upper section and a second, lower section. The interior diameter of the air pump chamber

first section is slightly larger than that of the air pump chamber second section. In addition, the air pump piston exterior surface has a first section and a second section. The exterior diameter of the second section of the exterior surface is larger than the exterior diameter of the first section of the exterior surface. The exterior diameter of the second
5 section of the air pump piston exterior surface is also larger than the interior diameter of the second section of the air pump chamber interior surface, but is smaller than the interior diameter of the first section of the air pump chamber interior surface. Thus, when the pump plunger is manually depressed downwardly moving the liquid pump piston and the air pump piston toward their discharge positions in their respective liquid pump chamber
10 and air pump chamber, the second exterior surface section of the air pump piston will engage in sealing contact with the second section of the air pump chamber interior surface, pressurizing the air in the air pump chamber. The pressurized air eventually opens the tube valve and is discharged into the liquid passage where it mixes with the liquid being discharged from the liquid pump chamber. On the reverse direction of the pump plunger
15 where the liquid pump piston and air pump piston are moved toward their charge positions, the second section of the air pump piston exterior surface still engages with the second section of the air pump piston interior surface for a portion of the pump plunger movement to produce a vacuum in the air pump chamber. However, when the air pump piston reaches its charge position, the second section of the air pump piston exterior surface is
20 positioned inside the first section of the air pump chamber interior surface where it disengages from the air pump chamber interior surface. This allows the vacuum produced in the air pump chamber to draw in air from the exterior environment of the dispenser into the air pump chamber. This venting of air into the air pump chamber is accomplished without the need for an additional check valve.

25 Thus, the liquid foaming dispenser of the invention provides the mixing of the liquid and air under pressure in the liquid discharge passage to produce the desired foam.

However, the construction of the dispenser eliminates a valve assembly from the air pump chamber that is required in prior art foaming liquid dispensers of this type. The reduced number of component parts of the dispenser of the invention allows it to be manufactured more economically, overcoming the disadvantages associated with prior art liquid foaming
5 dispensers of this type.

Brief Description of the Drawings

Further features of the invention are set forth in the following detailed description of the preferred embodiment of the invention and in the drawing figures wherein:

10 Figure 1 is a cross-section elevation view of the liquid foaming dispenser of the invention in its charge position;

Figure 2 is a cross-section elevation view of the liquid foaming dispenser in its discharge position, as well as in its locked and sealed position;

15 Figure 3 is a partial enlarged view of the details of the dispenser shown in the area circled to the left in Figure 1;

Figure 4 is an enlarged partial view of the details of the dispenser shown circled to the right in Figure 1;

Figure 5 is an enlarged perspective view of the tubular check valve of the dispenser disassembled from the dispenser;

20 Figure 6 is a further embodiment of the air pump chamber; and,

Figure 7 is a still further embodiment of the air pump chamber.

Detailed Description of the Preferred Embodiment

The liquid foaming dispenser 10 of the present invention is similar to the types of
25 dispensers known in the art as lotion dispensers. These types of dispensers are typically operated by orienting the dispenser vertically upright. In the description of the liquid

foaming dispenser of the invention to follow, the terms "top" and "bottom", "upper" and "lower" or similar related terms will be used to describe the component parts of the dispenser. These terms are only used because the dispenser is typically oriented vertically upright when using the dispenser. The terms should not be interpreted as limiting.

5 The liquid foaming dispenser 10 shown in Figures 1 and 2 is basically comprised of a pump housing 12, a pump plunger 14 and a container cap and lock assembly 16. The materials employed in constructing the component parts of the dispenser are the same as those typically used in the industry, usually plastics except for a metal coil spring employed in the pump. Apart from the construction of a dispenser head and a locking assembly of the
10 dispenser which will be later described, the liquid foaming dispenser 10 of the invention is symmetric about a center axis 18 that extends downwardly through the dispenser and defines mutually perpendicular axial and radial directions.

 The pump housing 12 is basically constructed with four cylindrical sections. At the bottom of the pump housing 12 is a bottom tubular section 22 that receives a dip tube 24.
15 The dip tube 24 is inserted into the liquid container (not shown) with which the liquid foaming dispenser 10 is used. Just above this bottom section 22 is the cylindrical liquid pump chamber 26.

 The liquid pump chamber 26 has a cylindrical interior surface 28 that extends between a first, top end of the liquid pump chamber and a second, bottom end of the liquid
20 pump chamber. The bottom end of the liquid pump chamber has a circular bottom wall 32. Recessed into the center of the bottom wall 32 is a generally cone-shaped valve seat 34. The valve seat 34 has a conical seat surface that receives a ball valve 36. The ball valve 36 unseats from the seat surface of the valve seat 34 to permit liquid flow into the liquid pump chamber 26, and seats on the seating surface of the valve seat 34 as shown in Figure 1 to
25 prevent liquid flow from the pump chamber 26 to the dip tube 24. Just above the ball valve 36 is a ball valve cage 38 that confines the ball valve 36 to the area above the valve seat 34.

A liquid pump chamber sealing stopper 42 projects upwardly from the ball valve cage 38. A metal coil spring 44 is positioned in the liquid pump chamber 26 and engages against the ball valve cage 38 holding the cage in its position shown in Figure 1. At the top end of the liquid pump chamber 26, the chamber expands radially outwardly forming an annular interior surface 46 at the top of the chamber and an adjacent cylindrical interior surface 48 at the top of the chamber. The liquid pump chamber 26 then opens into the air pump chamber 52.

The air pump chamber 52 has a length with a top, first end and an opposite bottom, second end. A cylindrical interior surface comprised of a first interior surface section 54 and a second interior surface section 56 extends between the top and bottom ends. The first interior surface section 54 is above the second interior surface section 56 and has a slightly larger interior diameter than the second interior surface section 56. At the bottom of the second interior surface section 56, the air pump chamber has an annular bottom wall 58 with an opening at its center that communicates with the liquid pump chamber 26. As the second interior surface section 56 extends upwardly toward the top end of the air pump chamber, it meets with a tapered interior surface section 62 that merges into the first interior surface section 58. The top, first end of the air pump chamber 52 at the top of the first interior surface section 54 is open to the exterior environment of the dispenser 10.

The pump housing 12 also comprises a container cap and lock support cylinder 66. The cap and lock support cylinder 66 extends upwardly from the exterior of the air pump chamber 52 adjacent the top end of the air pump chamber. The cap and lock support cylinder 66 has a cylindrical side wall with a cylindrical interior surface 68. The cap and lock support cylinder 66 also has an annular end wall 72 at the bottom, second end of the cylinder that attaches the cylinder to the exterior of the air pump chamber 52. A vent hole 74 is provided through the annular wall 72 that vents the interior of a liquid container (not shown) to which the dispenser 10 is attached to the exterior environment of the dispenser.

An annular flange 76 projects radially outwardly from the top, first end of the cap and lock support cylinder 68.

The pump plunger 14 is basically comprised of a piston assembly and a dispenser head assembly. The piston assembly comprises a liquid pump piston rod 82 at the bottom
5 of the assembly. The liquid pump piston rod 82 is tubular and has a cylindrical interior surface 84 that extends through its entire length and defines a portion of the liquid discharge passage of the pump plunger 14. A liquid pump piston 86 is provided at the bottom of the liquid pump piston rod 82.

The liquid pump piston 86 engages in sliding, sealing engagement with the liquid
10 pump chamber interior surface 28. A tubular valve seat 88 that is integral with the liquid pump piston 86 extends upwardly into the interior of the liquid pump piston rod 82. The tubular valve seat 88 has a generally conical interior seating surface and a ball valve 92 rests on this surface. The tubular valve seat 88 defines a portion of the liquid discharge passage through the liquid pump piston rod 82 when the ball valve 92 is unseated from the interior
15 surface of the valve seat. The tubular valve seat 88 also functions in securing the liquid pump piston 86 to the bottom of the liquid pump piston rod 82. The engagement of the metal coil spring 44 against the liquid pump piston 86 also holds the liquid pump piston to the liquid pump piston rod 82. In addition, the interior bore of the tubular valve seat 88 where it merges with the liquid pump piston 86 has an interior diameter dimension that
20 receives the liquid pump chamber sealing stopper 42 in sealing engagement when the pump plunger 14 is in its discharge and lock position relative to the pump housing 12 which will be explained.

An annular sealing and locking collar 94 is mounted on the exterior surface of the liquid pump piston rod 82 in a sealing, sliding engagement. An exterior surface 96 of the
25 collar 94 is pressed into the liquid pump chamber cylindrical interior surface 48 at the top

of the liquid pump chamber securing the collar in place and sealing the liquid pump chamber 26 from the air pump chamber 52.

The top, first end of the liquid pump piston rod 82 merges into the bottom, second
5 end of the air pump piston rod 102. The air pump piston rod 102 has a cylindrical interior surface 104 that extends between the top, first end of the air pump piston rod to the bottom, second end of the air pump piston rod and defines a portion of the liquid discharge passage through the pump plunger. An annular bottom wall 106 joins the air pump piston rod 102 to the liquid pump piston rod 82. A pair of diametrically opposed valve openings
10 108, only one of which is seen in Figures 1, 2 and 3, extend through the annular bottom wall 106.

An air pump piston 112 is connected to the exterior of the air pump piston rod 102 by an annular wall 114 that extends radially outwardly from the air pump piston rod 102 to a top, first end of the air pump piston 112. The air pump piston 112 has a cylindrical
15 exterior surface with a first surface section 116 and a second surface section 118. As the air pump piston exterior surface extends downwardly from the first exterior surface section 116 adjacent the top of the air pump piston, to the second exterior surface section 118 adjacent the bottom, second end of the air pump piston, the exterior surface of the second exterior surface section 118 expands radially outwardly. The second exterior surface section 118
20 expands to the largest exterior diameter dimension of the air pump piston 112 at the bottom end 122 of the piston. The exterior diameter of the air pump piston exterior surface at the bottom end 122 is smaller than the interior diameter of the air pump chamber first interior surface section 54, but larger than the interior diameter of the air pump chamber second interior surface section 56. This dimensioning of the air pump piston provides a
25 sliding, sealing engagement between the air pump piston bottom, second end 122 and the

air pump chamber second interior surface section 56. From the air pump piston 112, the air pump piston rod 102 extends upwardly to an open top, first end 124 of the rod.

A tubular check valve 132 is assembled into the portion of the liquid discharge passage of the pump plunger 14 defined by the interior surface 104 of the air pump piston rod 102. As best seen in Figures 3 and 4, the tubular check valve 132 has a cylindrical bottom portion 134 with a center bore 136. The cylindrical bottom portion 134 is inserted into the top end of the liquid pump piston rod 82, securing the tubular check valve 132 to the liquid pump piston rod. An annular bottom wall 138 extends radially outwardly from the cylindrical bottom portion 134 of the valve and engages with the interior surface 104 of the air pump piston rod 102. The center bore 136 also extends through the bottom wall 138. A pair of diametrically opposed notches 142 are formed in the annular bottom wall 138 in positions that coincide with the valve openings 108 through the annular bottom wall 106 of the air pump piston rod 102. A resilient tubular sleeve 144 extends upwardly from the annular bottom wall 138 of the valve. The sleeve 144 is positioned radially inside the pair of notches 142. The sleeve has a cylindrical exterior surface 146 and an opposite cylindrical interior surface 148 that surrounds a center bore of the sleeve that defines a portion of the liquid discharge passage of the pump plunger.

The dispenser head assembly of the pump plunger 14 includes a dispenser head 152 that has a bottom tubular portion 154 that is inserted into the air pump piston rod 102 at the top end of the rod. The tubular portion 154 has an exterior surface 158 that engages against the interior surface 104 of the air pump piston rod 102, securing the dispenser head to the rod. The dispenser head 152 has a cylindrical interior surface 162 that defines a portion of the liquid discharge passage of the pump plunger 14. A lower portion of the dispenser head interior surface 164 tapers radially outwardly as it extends to the bottom end 166 of the dispenser head as shown in Figures 3 and 4. This provides a small spacing

between the dispenser head interior surface 164 at the bottom of the dispenser head and the exterior surface 146 of the resilient sleeve 144 of the tubular check valve 132.

A fluid disrupter 172 is positioned in the dispenser head in engagement with the interior surface 162 of the dispenser head. The fluid disrupter 172 has a small opening 174 that is screened or is provided with intersecting spokes that traverse the opening. The screened or spoked opening 174 of the fluid disrupter, as well as the interior of the disrupter, form a portion of the liquid discharge passage extending through the dispenser head 152.

The top of the dispenser head is provided with a spout 176 that extends to one side of the head. The spout 176 has an interior surface 178 that defines a portion of the liquid discharge passage extending through the dispenser head.

A sealing and locking sleeve 182 is mounted on the exterior surface of the dispenser head 152. The sleeve 182 is held in place by a bottom annular wall 184 of the sleeve that is positioned between the dispenser head 152 and the air pump piston rod 102. The sleeve 182 has an annular rim 186 that projects radially outwardly a small distance from the sleeve exterior surface. The bottom end of the sleeve 190 functions as a sealing stopper and has an exterior diameter dimension that is slightly larger than the interior diameter dimension of the air pump chamber first interior surface section 154. In addition, a lock tab 188 projects radially outwardly from the sleeve exterior surface.

The container cap and lock assembly includes a cylindrical container cap 192 that is mounted on top of the annular flange 76 of the cap and lock support cylinder 66 of the pump housing. Although not shown, the interior surface 194 of the container cap 192 would be provided with screw threading or bayonet connectors complementary to connectors of the liquid container with which the liquid foaming dispenser 10 is used. An inwardly projecting annular wall 196 at the top of the cylindrical cap 192 supports the cap on top of the annular flange 76 of the cap and lock support cylinder 66. A lock collar 198

secures the container cap 192 to the pump housing 12. The lock collar 198 has a lower cylindrical portion 200 with an exterior surface that engages against the interior surface of the cap and lock support cylinder 66, securely holding the container cap 192 between the lock collar 198 and the cap and lock support cylinder 66. An upper portion 202 of the lock collar has a radially inwardly projecting lock flange 204 that circles around the dispenser head 152. The lock collar flange 204 has an opening 206 that is dimensioned to receive the lock tab 188 on the dispensing head. The interior surface 208 of the lower cylindrical portion 200 has an interior diameter dimension that is slightly smaller than the exterior diameter dimension of the sealing and locking sleeve annular rim 186.

In operation of the liquid foaming dispenser with the dispenser attached to a liquid container (not shown) and the dip tube 24 extending into the liquid of the container, the pump plunger 14 is first positioned in the charge position relative to the pump housing 12 shown in Figure 1. The term "charge" is used herein to indicate the condition where the liquid pump chamber 26 and air pump chamber 52 have been charged or filled with liquid and air respectively. However, on initial pumping of the liquid foaming dispenser 10, in the position shown in Figure 1, the liquid pump chamber 26 and the air pump chamber 52 have not yet been primed and would be filled with air. The air pump piston bottom end 122, being spaced from the first interior surface section 54 of the air pump chamber 52, vents the air pump chamber to the exterior atmosphere of the dispenser.

The pump plunger 14 is then moved downwardly relative to the pump housing 12 toward the discharge positions of the pump pistons relative to the pump housing. The term "discharge" is used herein to indicate that the pistons are expelling the fluids contained in their respective pump chambers under pressure. With the liquid pump chamber ball valve 36 seated, downward movement of the liquid pump piston 86 compresses the air in the liquid pump chamber causing the piston ball valve 92 to unseat and the air in the liquid pump chamber to be discharged through the liquid discharge passage of the pump plunger.

The downward movement also compresses the spring 44 in the liquid pump chamber 26. In addition, the downward movement of the air pump piston 112 through the air pump chamber 52 causes the bottom end 122 of the piston to engage in sealing contact with the second interior surface section 56 of the air pump chamber, pressurizing the air in the air pump chamber. The pressurized air is transmitted through the valve openings 108 to the exterior surface 146 of the tubular check valve resilient sleeve 144, causing at least a portion of the sleeve to be displaced radially inwardly from its sealing contact with the bottom portion 164 of the dispenser head interior surface. This causes the air under pressure in the air pump chamber 52 to be discharged through the liquid discharge passage of the dispenser head 52.

Subsequent upward movement of the pump plunger 14 relative to the pump housing 12 by the compressed spring 44 causes the liquid pump piston upper ball valve 92 to seat preventing air from entering the liquid pump chamber from the dispenser head and creating a vacuum in the liquid pump chamber 26. This vacuum causes the liquid pump chamber lower ball valve 36 to unseat and draws liquid upward through the dip tube 24 and into the liquid pump chamber 26. The upward movement of the air pump piston 112 in the air pump chamber 52 also creates a vacuum in the air pump chamber. The exterior surface 146 of the tube valve sleeve 144 engages against the interior surface 164 of the dispenser head and prevents air from entering the air pump chamber 52 from the liquid discharge passage. The upward movement of the air pump piston 112 continues until the air pump piston 112 reaches the first interior surface section 54 of the air pump chamber where the bottom end 122 of the air pump piston disengages from the interior surface. This vents the air pump chamber 52 to the exterior environment of the liquid foaming dispenser causing air to enter into the air pump chamber 52.

Subsequent downward movement of the pump plunger 14 into the pump housing 12 pressurizes the contents of the air pump chamber 52. The liquid contained in the liquid

pump chamber 26 seats the lower ball valve 36 and displaces the upper ball valve 92 causing the liquid to move upwardly through the liquid discharge passage of the dispenser. The air under pressure in the air pump chamber 52 again causes the resilient sleeve 144 of the tubular check valve 132 to be displaced radially inwardly causing the air to move
5 upward through the vent openings 108 past the sleeve 144 and into the liquid in the liquid discharge passage. Both the air and the liquid pass through the disrupter opening 174 of the fluid disrupter 172 in the liquid passage of the dispenser head 152 creating a foam that is dispensed from the dispenser head 152.

The dispenser can also be locked in the discharge position to prevent leakage of any
10 of the liquid contents of the liquid container through the dispenser should the container and dispenser be positioned on their side. With the pump plunger 14 moved downwardly to its discharge position, the liquid pump chamber sealing stopper 420 engages in the interior bore of the liquid pump piston 86 just below the tubular valve seat 88. This seals the liquid pump chamber 26 from the liquid discharge passage extending through the liquid pump
15 piston rod 82 and the air pump piston rod 102. In addition, the annular rim 186 of the seal and lock sleeve 182 of the dispenser head engages against the interior surface of the lower cylindrical portion 200 of the lock collar 198 as shown in Figure 2. The bottom of the seal and lock sleeve 182 extends into the top opening of the air pump chamber 52 and seals against the first interior surface section 54 of the air pump chamber as also shown in
20 Figure 2. This seals the air pump chamber 52 against any liquid that would pass through the vent hole 74. This also prevents any liquid that would pass through the vent hole 74 from leaking out of the dispenser 10.

To lock the pump plunger 14 in the pump housing 12 in the sealed positions shown in Figure 2, the dispenser head is rotated so that the lock tab 188 on the seal and lock sleeve
25 182 is aligned with the opening 206 in the lock flange 204 of the lock collar 198. The tab 188 is passed through the opening 206 and the dispenser is rotated so that the tab engages

against the underside of the lock flange 204 as shown in Figure 2. This secures the pump plunger 14 in its locked and sealed position relative to the pump housing 12.

Figure 6 shows a variant embodiment of the liquid foaming dispenser 10 of the invention. In Figure 6 the larger interior diameter surface section 54 of the air pump chamber 52 previously described has been replaced by an axially extending rib 212. The other component parts of this variant embodiment of the dispenser remain the same. When the air pump piston 112 moves upwardly in the air pump chamber 52 to the extent that the bottom end 122 of the air pump piston engages with the rib 212, the rib 212 separates the air pump piston bottom end 122 from engagement with the interior surface of the air pump chamber 52 and thereby vents the interior of the air pump chamber to the exterior environment of the dispenser.

Figure 7 shows the detail of a still further embodiment of the liquid foaming dispenser 10. In Figure 7 the larger first interior diameter surface section 54 of the air pump chamber 52 has been replaced by an axially extending groove 214 in the interior surface of the air pump chamber. All the other component parts of the dispenser 10 remain the same. In this embodiment of the dispenser, when the air pump piston bottom end 122 moves upwardly and is positioned adjacent the axial groove 214, the groove 214 vents the interior of the air pump chamber 52 to the exterior environment of the dispenser 10.

The construction of the liquid foaming dispenser and its operations described above provide a liquid foaming dispenser that can produce and dispense a thick foam without requiring the additional component parts of prior art dispensers, in particular a valve assembly that controls the supply of air into the air pump chamber.

Although a preferred embodiment of the dispenser of the invention has been described above, it should be understood that variations and modifications could be made to the dispenser that are intended to be included in the scope of the following claims.

What Is Claimed Is

(1) A foaming liquid dispenser comprising:

a pump housing having a liquid pump chamber with a cylindrical interior
5 surface and an air pump chamber with a cylindrical interior surface;

a pump plunger in the pump housing, the plunger having an interior
discharge passage extending through the plunger;

a liquid pump piston and an air pump piston on the plunger, the liquid pump
piston and the air pump piston being mounted in the respective liquid pump chamber and
10 the air pump chamber for reciprocating movement between charge and discharge positions
of the liquid pump piston and the air pump piston in the respective liquid pump chamber
and the air pump chamber, where in the charge positions the liquid pump piston and air
pump piston each engage with the respective liquid pump chamber interior surface and air
pump chamber interior surface and in the discharge positions the liquid pump piston
15 engages with the liquid pump chamber interior surface and the air pump piston at least
partially disengages from the air pump chamber interior surface.

(2) The dispenser of Claim 1, further comprising:

the air pump piston being completely disengaged from the air pump chamber
interior surface in the discharge position.

20 (3) The dispenser of Claim 1, further comprising:

the air pump piston disengaging from the air pump chamber interior surface
venting the air pump chamber to an exterior environment of the dispenser.

(4) The dispenser of Claim 1, further comprising:

the air pump piston having a cylindrical exterior surface that extends around
25 the plunger and along the plunger between opposite first and second ends of the exterior
surface, the exterior surface having at least a first diameter dimension and a second

diameter dimension where the first diameter dimension is smaller than the second diameter dimension.

(5) The dispenser of Claim 1, further comprising:

the air pump piston having a cylindrical exterior surface that extends around
5 the plunger and along the plunger between opposite first and second ends of the exterior surface, and the air pump chamber interior surface extends around at least a portion of the air pump piston exterior surface in both the charge and discharge positions of the air pump piston relative to the air pump chamber.

(6) The dispenser of Claim 1, further comprising:

10 the air pump chamber interior surface having a length that extends along the plunger between opposite first and second ends of the air pump chamber interior surface, and the air pump chamber interior surface has at least first and second sections with respective first and second interior diameter dimensions where the first interior diameter dimension is larger than the second interior diameter dimension.

15 (7) The dispenser of Claim 6, further comprising:

the air pump piston engaging with the second section of the air pump chamber interior surface when the air pump piston is in the discharge position and the air pump piston disengaging from the first and second sections of the air pump chamber interior surface when the air pump piston is in the charge position.

20 (8) The dispenser of Claim 7, further comprising:

the plunger extending through the first interior surface section of the air pump chamber, then through the second interior surface section of the air pump chamber, and then extending into the liquid pump chamber.

(9) A foaming liquid dispenser comprising:

25 a pump housing having a liquid pump chamber with a cylindrical interior surface and an air pump chamber with a cylindrical interior surface, the air pump chamber

interior surface having a first section with a first interior diameter dimension and a second section with a second interior diameter dimension, the first interior diameter dimension being larger than the second interior diameter dimension;

5 a pump plunger in the pump housing, the plunger having an interior discharge passage extending through the plunger;

a liquid pump piston and an air pump piston on the plunger, the liquid pump piston and the air pump piston being mounted in the respective liquid pump chamber and air pump chamber for reciprocating movement between charge and discharge positions of the liquid pump piston and air pump piston in the respective liquid pump chamber and air pump chamber, and the air pump piston having a cylindrical exterior surface with an exterior diameter dimension that is larger than the interior diameter dimension of the second section of the air pump chamber interior surface and is smaller than the interior diameter dimension of the first section of the air pump chamber interior surface.

10

(10) The dispenser of Claim 9, further comprising:

15 the cylindrical interior surface of the liquid pump chamber and the cylindrical interior surface of the air pump chamber being coaxial.

(11) The dispenser of Claim 1, further comprising:

the air pump piston exterior surface engaging with the air pump chamber interior surface when the air pump piston is moved to the discharge position and the air pump piston exterior surface disengaging from the air pump chamber interior surface when the air pump piston is moved to the charge position.

20

(12) The dispenser of Claim 11, further comprising:

the air pump chamber interior surface extending around the air pump piston exterior surface when the air pump piston is in the charge position.

(13) The dispenser of Claim 11, further comprising:

the air pump piston exterior surface disengaging from the air pump chamber interior surface completely around the cylindrical exterior surface of the air pump piston and venting the air pump chamber to an exterior environment of the dispenser when the air
5 pump piston is moved to the charge position.

(14) A foaming liquid dispenser comprising:

a pump housing having a liquid pump chamber and an air pump chamber;
a pump plunger in the pump housing, the plunger having an interior
discharge passage extending through the plunger;

10 a liquid pump piston and an air pump piston on the plunger, the liquid pump piston and the air pump piston being mounted in the respective liquid pump chamber and air pump chamber for reciprocating movement between charge and discharge positions of the liquid pump piston and the air pump piston in the respective liquid pump chamber and air pump chamber; and,

15 an air pump stopper on the plunger that engages with and seals the air pump chamber when the liquid pump piston and the air pump piston are moved to the discharge positions.

(15) The dispenser of Claim 14, further comprising:

the air pump chamber having a cylindrical interior surface with a center axis;
20 and,
the stopper engaging inside the air pump chamber interior surface to seal the air pump.

(16) The dispenser of Claim 14, further comprising:

a discharge passage stopper on the pump housing that engages with and seals
25 the discharge passage when the liquid pump piston and the air pump piston are moved to the discharge position.

(17) The dispenser of Claim 16, further comprising:

the discharge passage stopper being in the liquid pump chamber.

(18) The dispenser of Claim 14, further comprising:

a lock flange on the pump housing; and,

5 a lock tab on the pump plunger, the lock tab being engagable with the lock flange to keep the liquid pump piston and the air pump piston in the discharge positions and the air pump stopper engaging with the air pump chamber.

(19) The dispenser of Claim 14, further comprising:

the pump housing having an opening to the air pump chamber;

10 the plunger extending through the opening; and,

the air pump stopper closing the opening when the liquid pump piston and the air pump piston are moved to the discharge positions.

(20) The dispenser of Claim 14, further comprising:

the liquid pump chamber having a length with opposite first and second

15 ends, the pump plunger extending into the liquid pump chamber through the first end; and,

a liquid passage stopper in the liquid pump chamber at the second end where the liquid passage stopper engages with and seals the discharge passage when the liquid pump piston and the air pump piston are moved to the discharge position.

(21) The dispenser of Claim 14, further comprising:

20 the air pump chamber having a length with opposite first and second ends,

the liquid pump chamber being at the air pump chamber second end and the pump plunger extending into the air pump chamber at the first end and into the liquid pump chamber at the second end, and the air pump stopper engaging with the air pump chamber at the first end.

25 (22) A foaming liquid dispenser comprising:

a pump housing having a liquid pump chamber and an air pump chamber;

a pump plunger in the pump housing, the plunger having an interior discharge passage extending through the plunger;

a liquid pump piston and an air pump piston on the plunger, the liquid pump piston and the air pump piston being mounted in the respective liquid pump chamber and air pump chamber for reciprocating movement between charge and discharge positions of the liquid pump piston and the air pump piston in the respective liquid pump chamber and air pump chamber;

a valve opening extending through the plunger between the air pump chamber and the discharge passage; and,

10 a valve element overlying the valve opening.

(23) The dispenser of Claim 22, further comprising:
the valve element is tubular.

(24) The dispenser of Claim 22, further comprising:

15 the valve opening is positioned between the liquid pump piston and the air pump piston on the plunger.

(25) The dispenser of Claim 22, further comprising:
the valve element extending around the discharge passage.

(26) The dispenser of Claim 22, further comprising:
the valve element being mounted inside the discharge passage.

20 (27) The dispenser of Claim 26, further comprising:
the plunger having an interior surface around the discharge passage and the valve element engaging against the plunger interior surface over the valve opening.

(28) The dispenser of Claim 27, further comprising:
the valve element being flexible and resilient where a flexibility of the valve element enables the valve element to flex away from the plunger interior surface opening

25

the valve opening and a resilience of the valve element biases the valve element against the plunger interior surface closing the valve opening.

- (29) The dispenser of Claim 23, further comprising:
the discharge passage passing through the valve element.

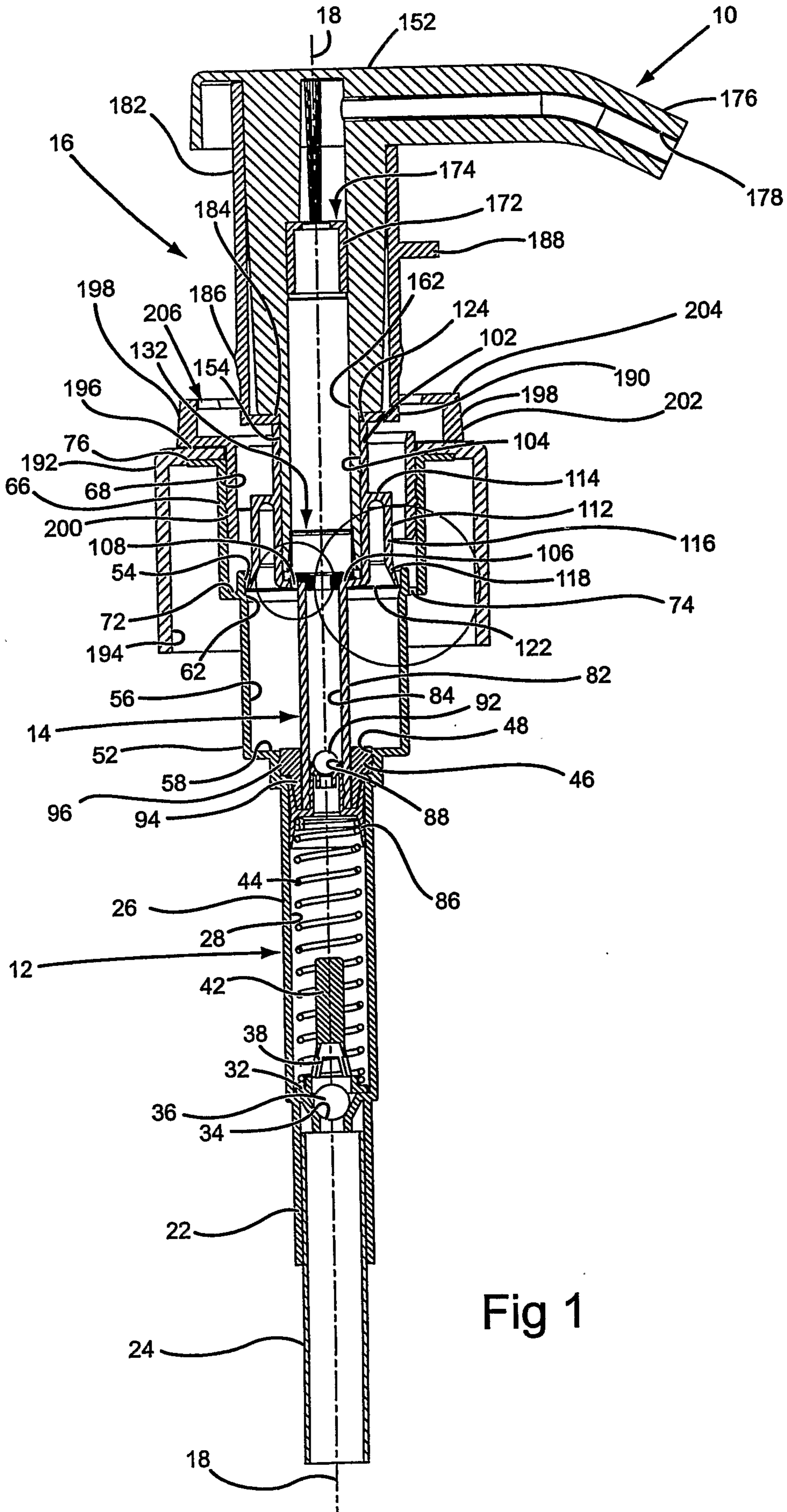

Fig 1

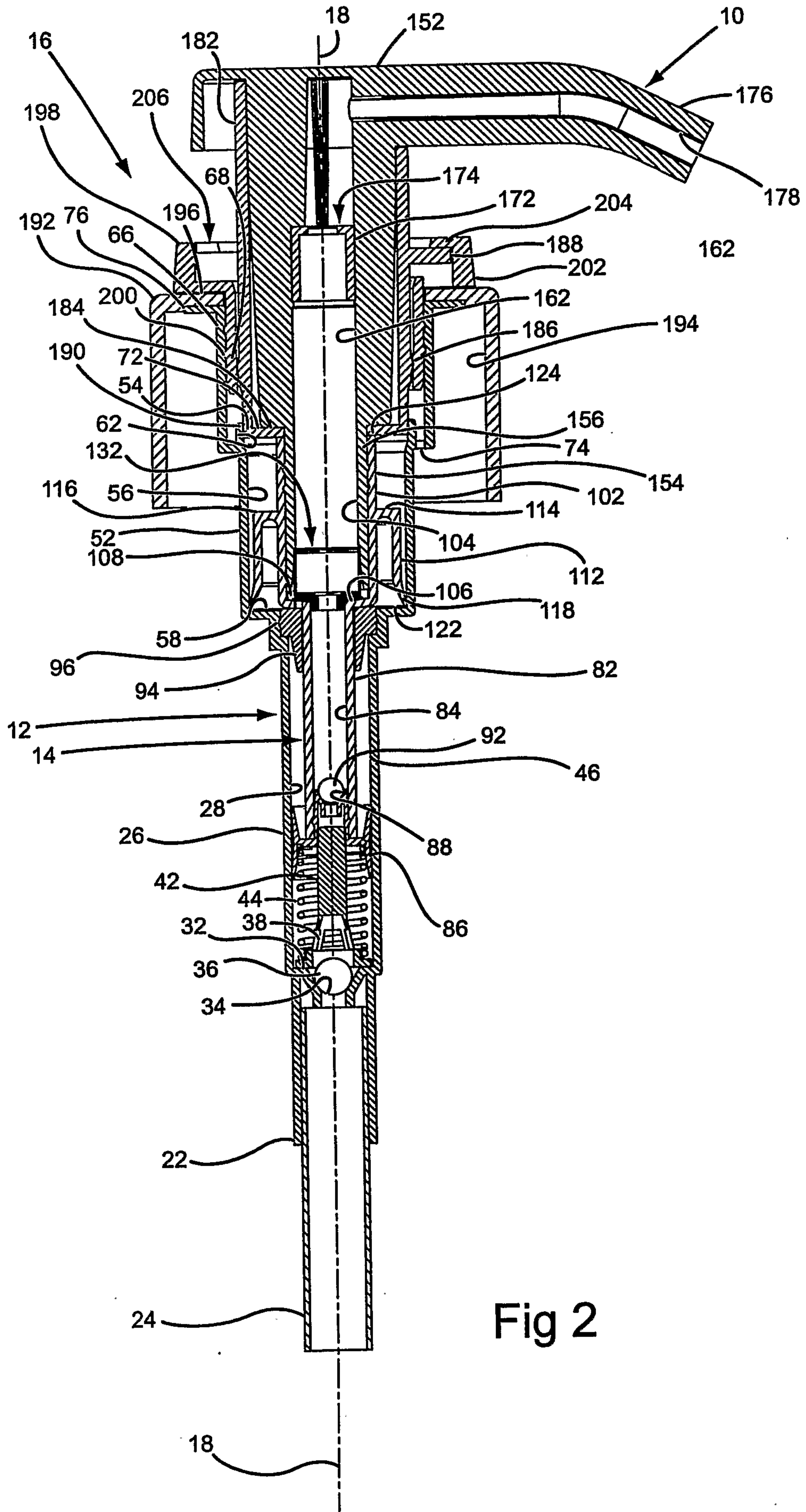

Fig 2

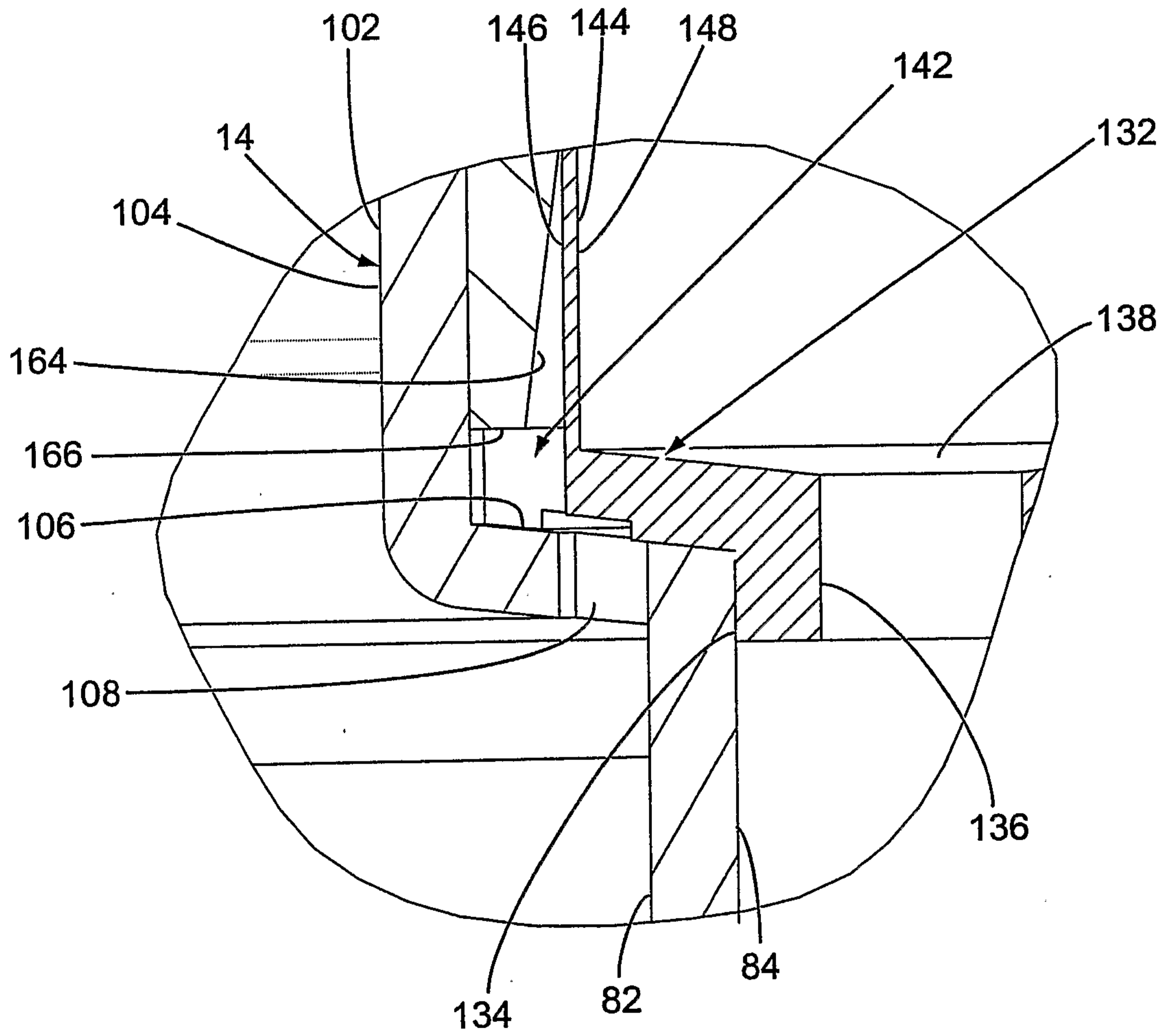

Fig 3

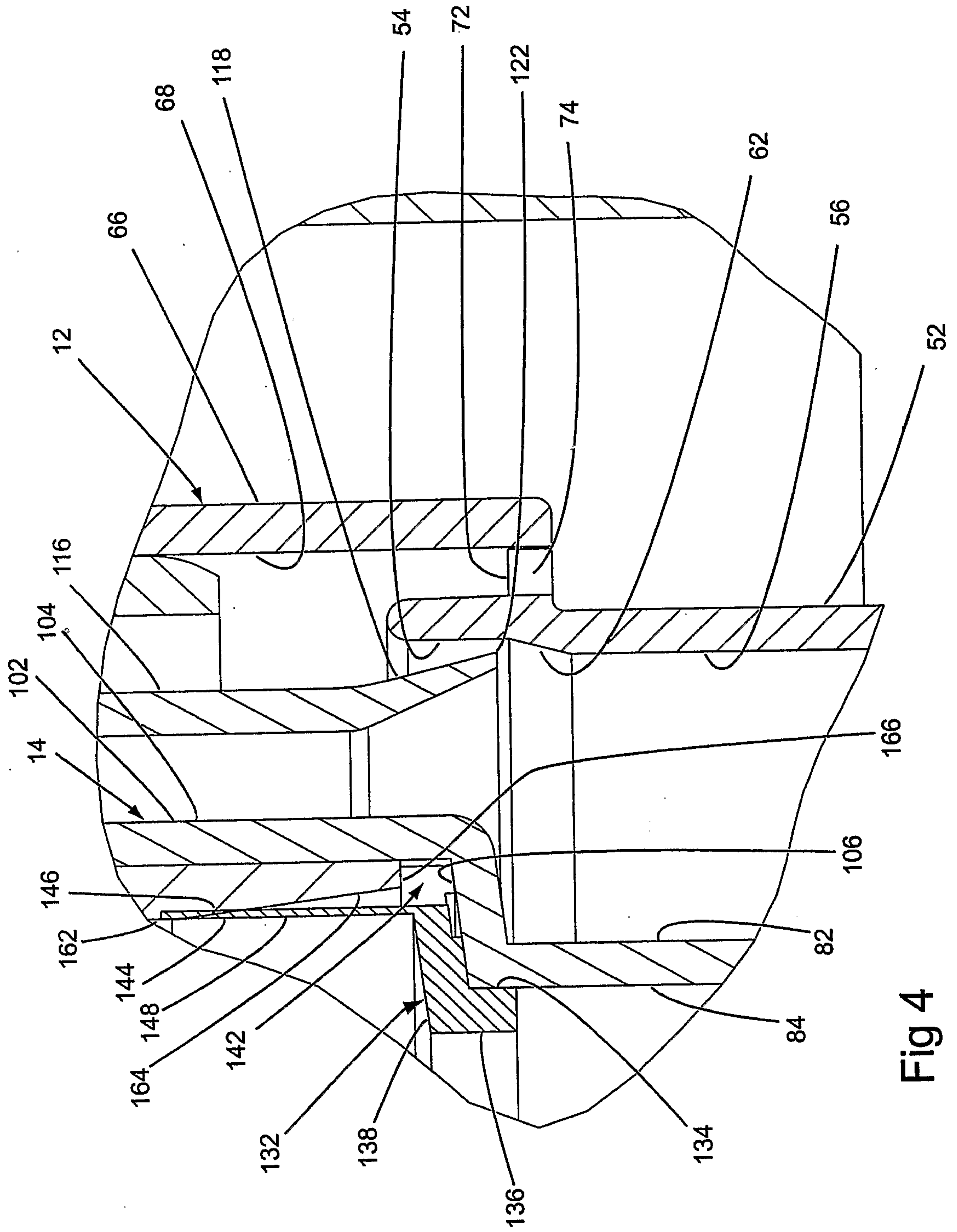

Fig 4

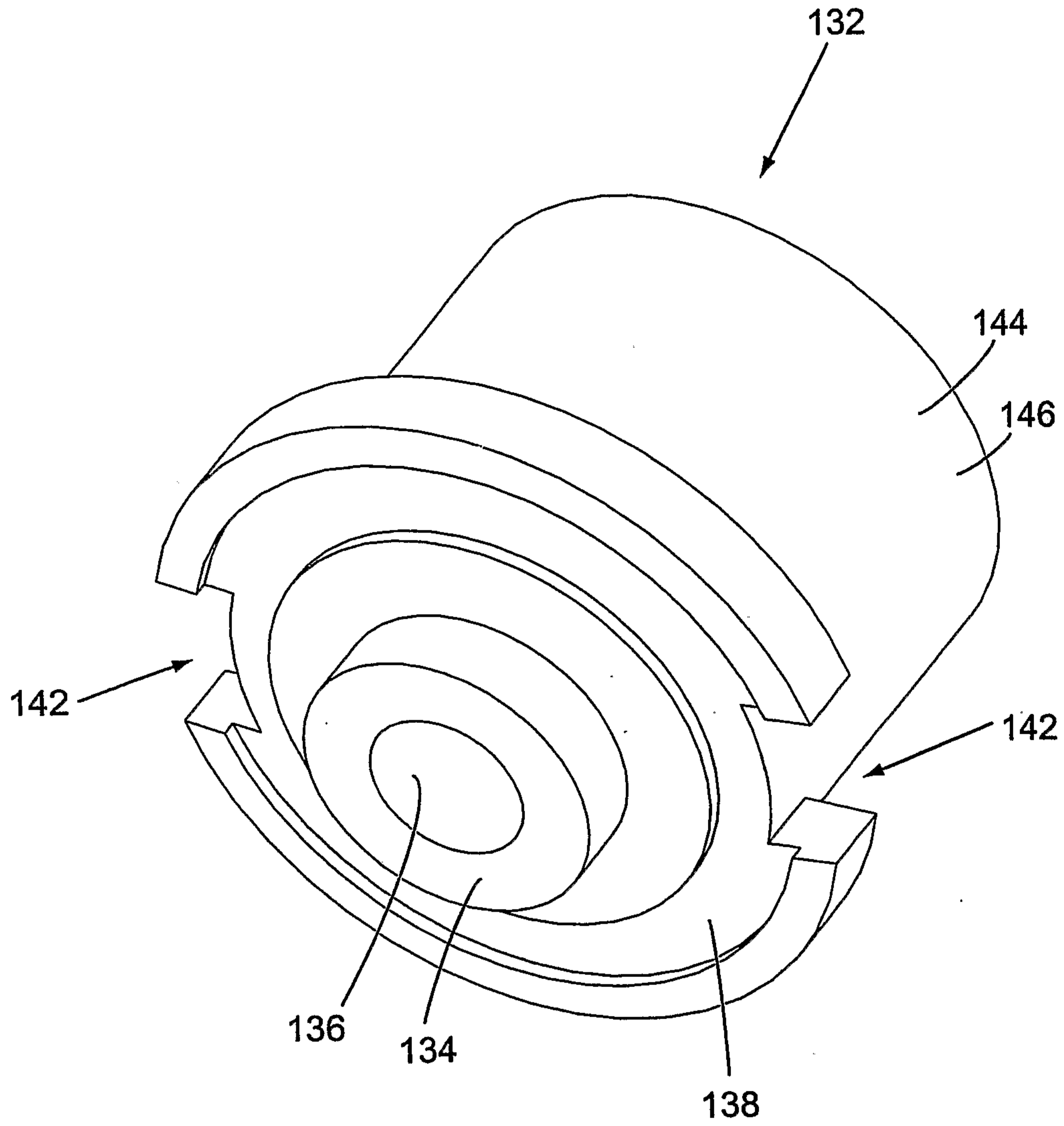

Fig 5

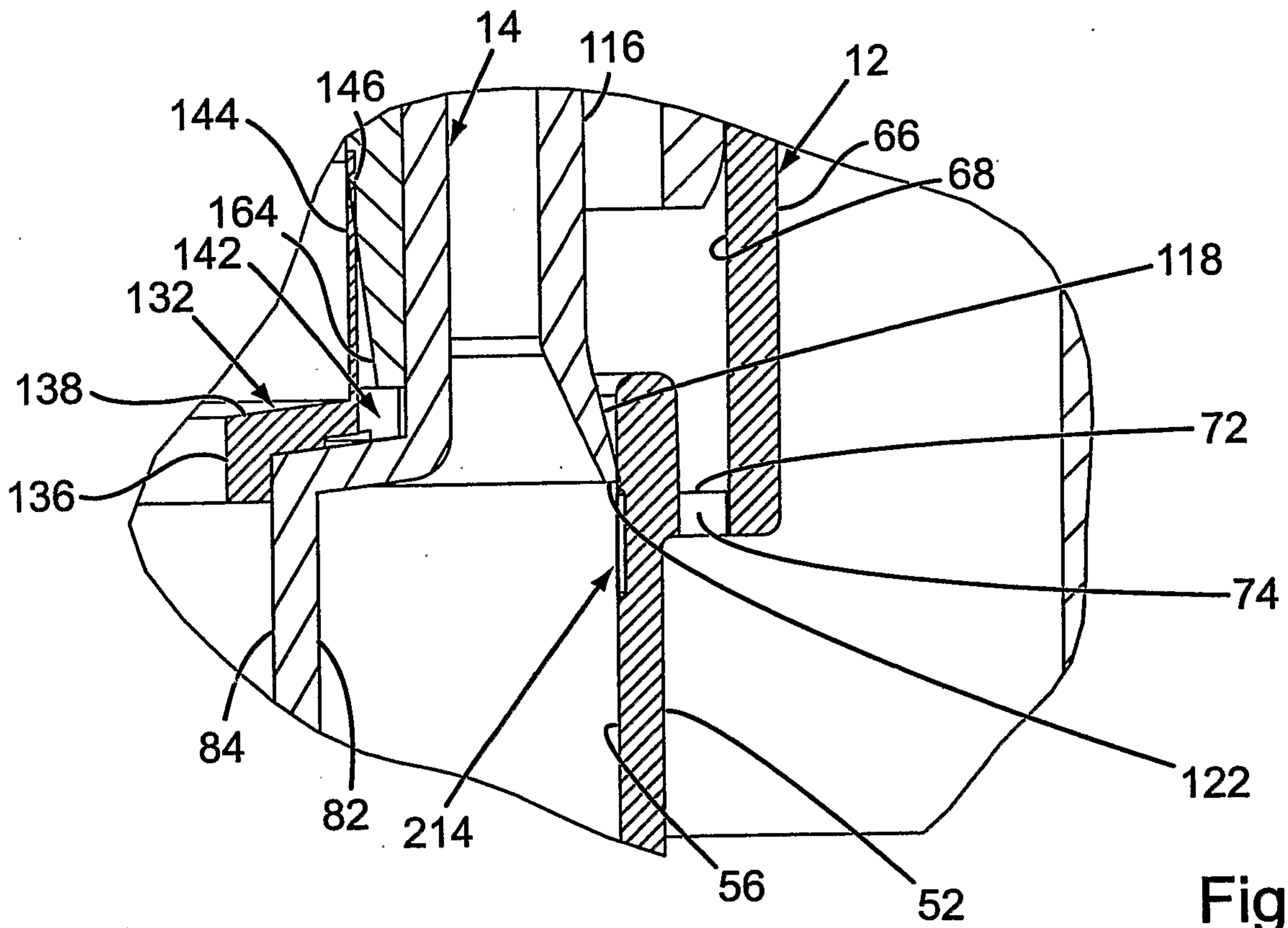

Fig 7

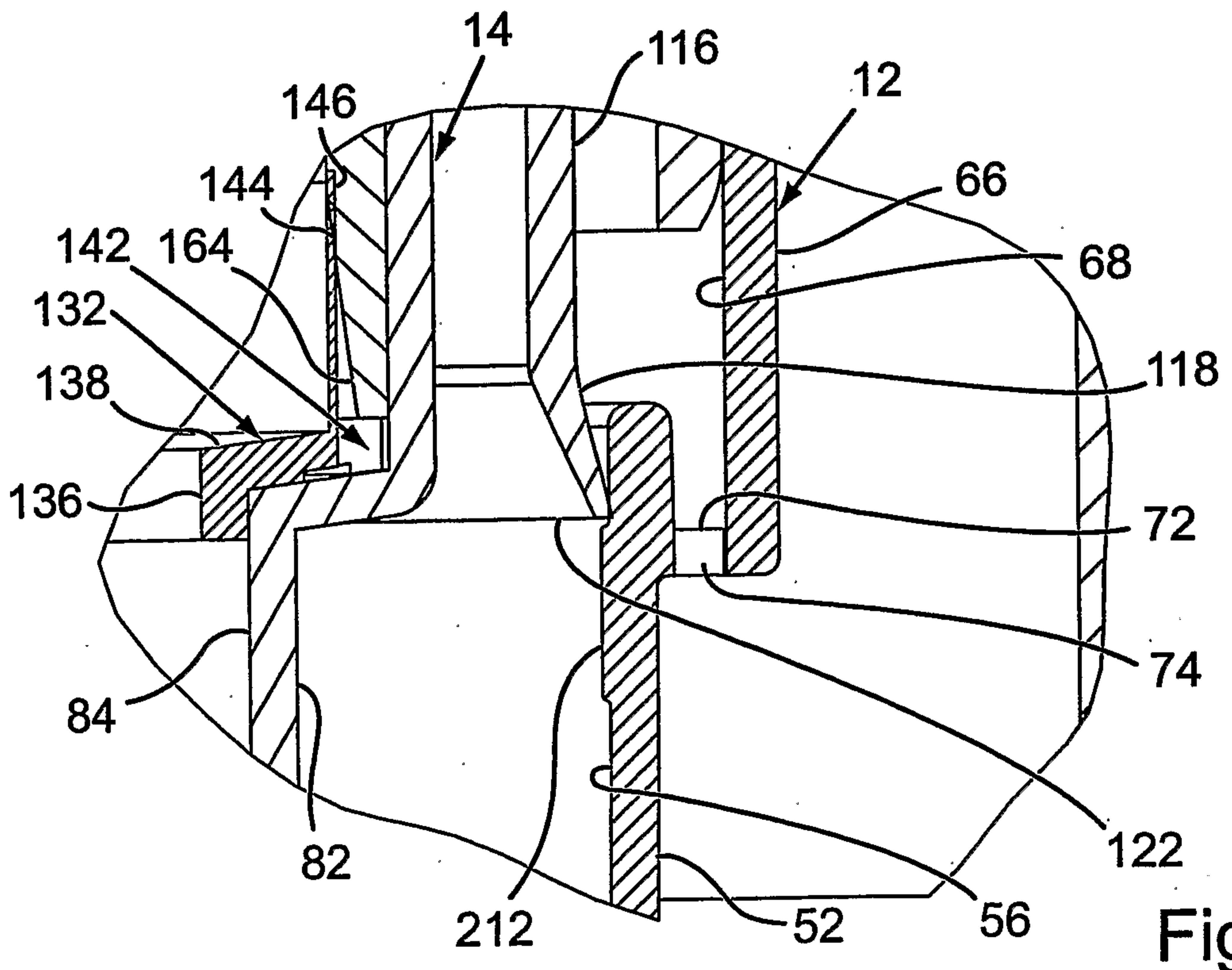

Fig 6

