

No. 633,555.

Patented Sept. 19, 1899.

A. L. F. MITCHELL & W. A. RHODES.  
FEEDING DEVICE FOR AUTOMATIC WEIGHING MACHINES.

(Application filed Feb. 14, 1898.)

(No Model.)

FIG. 1.

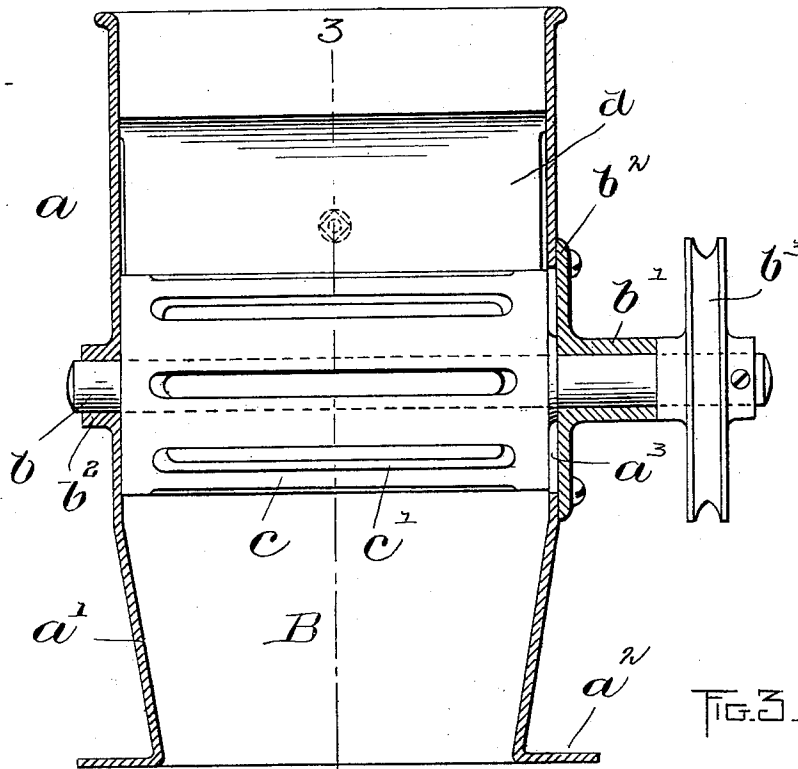
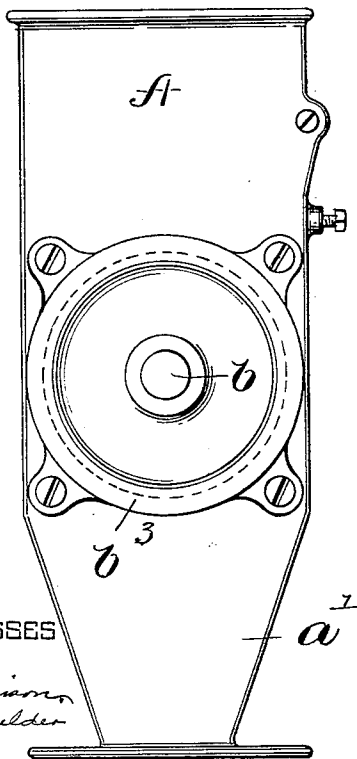

FIG. 2.



WITNESSES

A. D. Hammon  
E. Batchelder

FIG. 3.

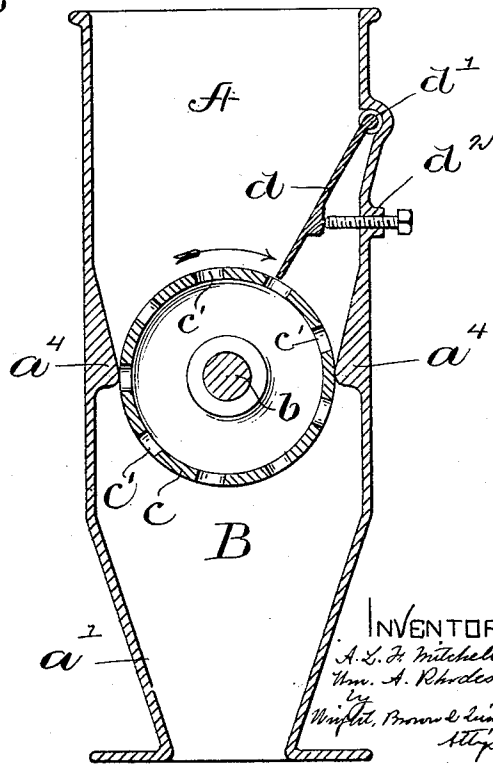

INVENTORS

A. L. F. Mitchell  
Wm. A. Rhodes  
By  
Wm. H. Brown & Co.  
Attys.

# UNITED STATES PATENT OFFICE.

ALBION L. F. MITCHELL, OF BOSTON, AND WILLIAM A. RHODES, OF MEDFORD, MASSACHUSETTS; SAID RHODES ASSIGNOR TO THE NEW ENGLAND AUTOMATIC WEIGHING-MACHINE COMPANY, OF PORTLAND, MAINE.

## FEEDING DEVICE FOR AUTOMATIC WEIGHING-MACHINES.

SPECIFICATION forming part of Letters Patent No. 633,555, dated September 19, 1899.

Application filed February 14, 1898. Serial No. 670,186. (No model.)

*To all whom it may concern:*

Be it known that we, ALBION L. F. MITCHELL, of Boston, in the county of Suffolk, and WILLIAM A. RHODES, of West Medford, in the county of Middlesex, State of Massachusetts, have invented certain new and useful Improvements in Feeding Devices for Automatic Weighing-Machines, of which the following is a specification.

The object of this invention is to provide a feeding device for automatic weighing-machines by means of which a steady uniform delivery of the material to be weighed may be insured. Heretofore difficulty has been experienced in feeding pulverulent and granular material at an even and uniform rate to weighing-machines because of the varying pressure upon the lower portion of the column of material in the hopper from which the material is delivered, the pressure varying with the height of the column, so that it has heretofore been impossible to secure a uniform feed and the delivery of the material at a definite rate regardless of the height of the column or accumulation of material above the weighing-machine.

Our invention is embodied in a feeding device designed to be interposed between the column of material in the hopper and the weighing-machine and to intercept the material and discharge it to the weighing mechanism in a continuous uniform stream, whereby but little material will be wasted and the weighing may be done with great accuracy.

Reference is to be had to the accompanying drawings, and to the letters marked thereon, forming a part of this specification, the same letters designating the same parts or features, as the case may be, wherever they occur.

Figure 1 represents in partial section a feeding device embodying our invention. Fig. 2 represents a side elevation of the same. Fig. 3 represents a transverse vertical section on the line 3 3 of Fig. 1.

Referring to the drawings,  $a$  indicates a casing, which may be of any suitable form and has its side walls formed with converging portions  $a^1 a^1$ , forming a throat between the

receiving and delivering ends of the casing. This casing may form a portion of the spout or duct which leads from the hopper to the weighing-machine, the lower end of the casing being flanged, as at  $a^2$ , for attachment to the casing of the machine.

A shaft  $b$  is journaled in a bearing  $b^2$  at one end of the throat of the casing and in a bearing-sleeve  $b^1$ , formed on a detachable plate  $b^2$ , secured to the casing at the other end of said throat. The plate  $b^2$  is flanged to cover an opening  $a^3$  in one end of the casing, through which opening the rotary feeding device  $c$  may be introduced into the casing. Said feeding device is a hollow roll or cylinder having closed ends and secured rigidly upon the shaft  $b$ , the cylinder being formed to substantially fill the throat of the casing, so that material can pass through the throat only by way of the cylinder.

The rotary feeding-cylinder  $c$  is provided with longitudinal slots  $c^1$ , which preferably extend practically from end to end of the cylinder, their edges being in the nature of shear or cutting edges, so that they detach material from the body or column resting upon the roll.

In order to regulate the flow of material through the cylinder, we employ a regulator consisting of a deflector-plate  $d$ , pivoted or fulcrumed at  $d^1$  and adapted to be adjusted by an adjusting-screw  $d^2$ , passed through the side wall of the casing, said plate being adjustable to vary the area of the cylinder exposed to contact with the column of material.

On the end of the shaft  $b$  is secured a belt-wheel  $b^3$ , by means of which the shaft and the cylinder are rotated, preferably at a speed of one hundred and fifty to two hundred revolutions per minute.

In operation the material is delivered from the hopper into the upper portion A of the casing and drops upon the rotary cylinder as the latter rapidly rotates. The edges of the slots scrape away the granular or pulverulent material, which drops through the slots and is thrown by centrifugal action into the lower portion B of the casing. Thus the material

is fed in a constant uniform stream to the weighing-machine, whereby the latter may be operated to weigh the material with accuracy.

The rotary member *c*, which is formed with the alternating slots and curved surfaces, entirely closes the throat through the casing and supports the body of material which is fed thereto, although the said material is free to pass in limited quantities through said slots into the interior of the cylinder and be discharged through those slots which are below the plane of the throat by centrifugal action. Thus by forming the said member with slots which extend entirely through its shell it is impossible for the pulverulent material to become packed therein, as it would were the slots merely grooves or pockets, and hence the said material is delivered in a fine free state and not in lumps or compressed masses. Moreover, by reason of the material passing through the body of the rotary member or cylinder it is delivered in a continuous stream, as has been previously stated, by reason of its being thrown from the lower half thereof not intermittently, as when a grooved or socketed delivery-roll is used. The said rotary member being hollow and formed with slots, as described, forms an intermediate chamber for the temporary reception of the granular or pulverulent material in loose or unpacked condition and for the discharge of said material in the same or still looser condition to the outlet of the chute or passage-way. The upper portion of the hollow rotary cylinder forms an upper movable wall, through the slots of which the material must pass in loosened condition, while, since the cross-sectional area of the cylinder or intermediate chamber is greater than that of the chute or passage-way immediately above it, the material cannot become packed in said chamber. Furthermore, the motion of the walls of the cylinder causes the material to pass through the lower wall not only in the same loose or a looser condition, but has a tendency to pass the material out of the cylinder or chamber faster than it enters it, for the reason that the outward passage is aided by centrifugal action.

We do not claim herein a feeding device of the character specified comprising a construction involving a movable member having anything in the nature of pockets within which the material is deposited and held in a solid mass while being transferred to a position for discharge therefrom. As hereinbefore stated, our device comprehends, in this connection, only a member into which the pulverulent material enters in a loose state and from which said material is discharged in a fine free state and not in lumps or compressed masses. We also do not claim a device having a valve member provided with a direct passage through it which alternately cuts off and opens the passage-way through the chute.

Having thus explained the nature of the

invention and described a way of constructing and using the same, although without attempting to describe all of the forms in which it may be made or all of the modes of its use, we declare that what we claim is—

1. A feeding device for pulverulent or granular material comprising a chute or passage-way provided with an intermediate chamber between its upper and lower portions, said chamber having movable slotted walls and adapted to receive said material through its upper wall in loosened condition, the lower portion of the chute or passage-way being below the intermediate chamber and adapted to receive the material therefrom through the lower wall of the said chamber.

2. A feeding device of the character described, comprising a casing and a hollow rotary member having passages through its walls and located in said casing, said member supporting the column of material and constructed and arranged to discharge it by centrifugal action.

3. A feeding device of the character described, comprising a casing having an inlet and an outlet orifice, and a rotary member placed in said casing between said orifices to support the column of material, said rotary member being provided with a series of slots to permit said material to pass through its body, the lower or outlet orifices being below the rotary member.

4. A feeding device of the character described, comprising a casing having an inlet and an outlet orifice, and a rotary tubular cylinder mounted in the said casing and provided with a series of slots in its periphery whereby the material passes into the interior of the member and is delivered therefrom by centrifugal action, the lower or outlet orifices being below the rotary member.

5. A feeding device of the character described, comprising a casing having a throat, a rotary tubular cylinder practically filling said throat so as to support the column of material, said cylinder being provided with a series of slots, the outlet from said casing being below the tubular slotted cylinder, and means for varying the exposed area of the cylinder.

6. A feeding device comprising a casing having a throat, a bearing at one end of said throat, an orifice in the throat at the end opposite said bearing, a rotary slotted or perforated hollow cylinder formed to practically fill the throat, and support the column of material, said slots permitting the passage of material into the interior of the cylinder from which it is discharged by centrifugal action, and a detachable plate formed to cover said orifice and provided with a bearing for one end of said cylinder, the cylinder being insertible and removable through said orifices when the plate is removed.

7. A feeding device of the character described, comprising a casing adapted to re-

5 ceive a column of material, a hollow rotary member in said casing for supporting said column of material, said member having alternating slots and curved surfaces, whereby the material is permitted to pass into said member by gravity and is discharged by centrifugal action.

In testimony whereof we affix our signatures in presence of two witnesses.

ALBION L. F. MITCHELL.  
WILLIAM A. RHODES.

Witnesses:

E. BATCHELDER,  
A. D. HARRISON.