



(51) International Patent Classification:

F24C 15/00 (2006.01) F24C 7/08 (2006.01)
F24C 14/02 (2006.01)

(21) International Application Number:

PCT/EP2013/076605

(22) International Filing Date:

13 December 2013 (13.12.2013)

(25) Filing Language:

English

(26) Publication Language:

English

(30) Priority Data:

A 2012/15357 26 December 2012 (26.12.2012) TR

(71) Applicant: ARCELIK ANONIM SIRKETI [TR/TR]; E5
Ankara Asfalti Uzeri, Tuzla, 34950 Istanbul (TR).

(72) Inventors; and

(71) Applicants : COSAN, Ahmet Ferit [TR/TR]; E5 Ankara
Asfalti Uzeri, Tuzla, 34950 Istanbul (TR). KARA, Tahir
[TR/TR]; E5 Ankara Asfalti Uzeri, Tuzla, 34950 Istanbul
(TR).

(81) Designated States (unless otherwise indicated, for every

kind of national protection available): AE, AG, AL, AM, AO, AT, AU, AZ, BA, BB, BG, BH, BN, BR, BW, BY, BZ, CA, CH, CL, CN, CO, CR, CU, CZ, DE, DK, DM, DO, DZ, EC, EE, EG, ES, FI, GB, GD, GE, GH, GM, GT, HN, HR, HU, ID, IL, IN, IR, IS, JP, KE, KG, KN, KP, KR, KZ, LA, LC, LK, LR, LS, LT, LU, LY, MA, MD, ME, MG, MK, MN, MW, MX, MY, MZ, NA, NG, NI, NO, NZ, OM, PA, PE, PG, PH, PL, PT, QA, RO, RS, RU, RW, SA, SC, SD, SE, SG, SK, SL, SM, ST, SV, SY, TH, TJ, TM, TN, TR, TT, TZ, UA, UG, US, UZ, VC, VN, ZA, ZM, ZW.

(84) Designated States (unless otherwise indicated, for every

kind of regional protection available): ARIPO (BW, GH, GM, KE, LR, LS, MW, MZ, NA, RW, SD, SL, SZ, TZ, UG, ZM, ZW), Eurasian (AM, AZ, BY, KG, KZ, RU, TJ, TM), European (AL, AT, BE, BG, CH, CY, CZ, DE, DK, EE, ES, FI, FR, GB, GR, HR, HU, IE, IS, IT, LT, LU, LV, MC, MK, MT, NL, NO, PL, PT, RO, RS, SE, SI, SK, SM, TR), OAPI (BF, BJ, CF, CG, CI, CM, GA, GN, GQ, GW, KM, ML, MR, NE, SN, TD, TG).

[Continued on next page]

(54) Title: PYROLYTIC OVEN

Figure 1

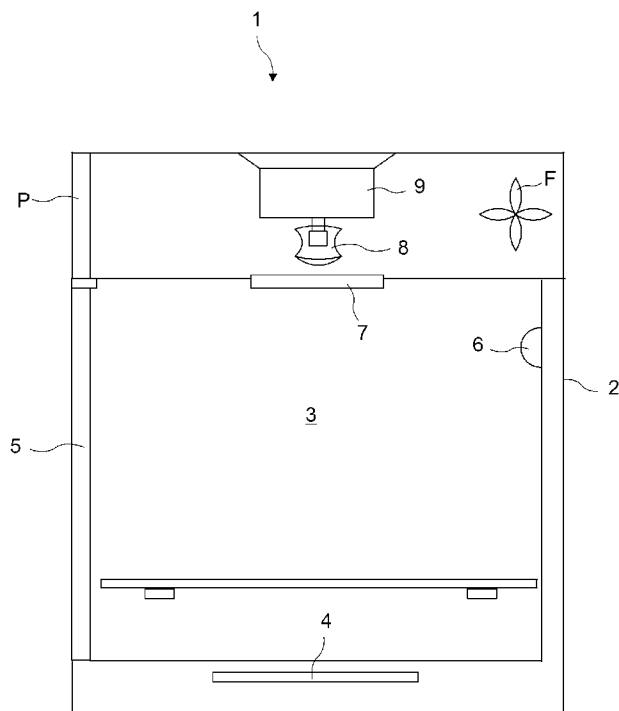

(57) Abstract: The present invention relates to an oven (1) comprising a body (2), a cooking chamber (3) disposed within the body (2), wherein the cooking process is performed, a heater (4) that provides the pyrolytic cleaning to be implemented by heating the cooking chamber (3) to high temperature values, a door (5) providing access into the cooking chamber (3), produced at least partially from glass and a light source (6) that provides the illumination of the interior of the cooking chamber (3). A transparent plate (7) is disposed on the side or upper wall of the cooking chamber (3), a light sensor (8) is disposed outside the cooking chamber (3), behind the transparent plate (7) and detects the light waves emitted from the light source (6) into the cooking chamber (3) and passing through the transparent plate (7), and a control unit (9) determines the dirtiness level of the cooking chamber (3) by evaluating the light intensity data detected by the light sensor (8).

Published:

— with international search report (Art. 21(3))

— before the expiration of the time limit for amending the claims and to be republished in the event of receipt of amendments (Rule 48.2(h))

Description**PYROLYTIC OVEN**

- [0001] The present invention relates to a pyrolytic oven having self cleaning feature, wherein the level of dirtiness is detected.
- [0002] In state of the art ovens, the self cleaning feature is a feature demanded by the user since cleaning the interior of the oven is difficult. During cooking, particles like splattered oil adhere to inner walls of the oven and cleaning the dirt becomes difficult when the oven is used several times without cleaning. In ovens, the most widespread method used for self cleaning function is the pyrolytic cleaning method. In pyrolytic ovens, pyrolytic cleaning is performed automatically or upon desire of the user, the dirt adhered to the oven walls is enabled to be cleaned by burning down by operating the heaters at high temperatures like 500 °C. The level of dirtiness inside the oven is measured in order to start the pyrolytic cleaning process automatically, and when the dirtiness level exceeds a certain limit, the automatic cleaning process is started. In the state of the art, sensor systems that detect the dirtiness level inside the oven are used in order to automatically perform the pyrolytic cleaning in ovens. The sensors that detect the dirtiness level are affected from the hot and humid environment inside the oven and malfunction, thereby the dirtiness level cannot be detected correctly.
- [0003] In the United States Patent Application No. US2011011422, a capacitive type sensor is disclosed that detects the pollution level in order to start the pyrolytic cleaning process automatically. By means of the capacitive sensor, the pollution is detected by the change in capacitance on the surface where the pollution is measured. Humidity and heat inside the oven increase conductivity between the electrodes of the capacitive sensor and causes erroneous measurement.
- [0004] The aim of the present invention is the realization of an oven wherein the dirtiness level is detected precisely and correctly and the pyrolytic cleaning process is performed.
- [0005] The oven realized in order to attain the aim of the present invention, explicated in the first claim and the respective claims thereof, comprises a

transparent plate disposed in an opening formed at the side or upper wall of the cooking chamber and produced from heat resistant glass, and a light sensor, for example a phototransistor or photodiode, disposed behind the transparent plate so as to remain outside the cooking chamber.

- [0006] The control unit compares the data of light intensity passing from the transparent plate and detected by the light sensor with the reference light intensity value determined for the clean oven interior and recorded in its memory.
- [0007] If the light intensity measured by the light sensor is lower than the reference light intensity by as much as a predetermined amount, the control unit decides that the dirtiness level on the transparent plate and hence in the cooking chamber has increased and that the pyrolytic cleaning process is required.
- [0008] The control unit first brings the light source to the off position for determining the dirtiness level and enables the light sensor to detect whether the oven is located in dark or luminous outside environment and afterwards brings the light source to the open position and applies different dirtiness level measurement algorithms with respect to dark or luminous outside environments.
- [0009] In an embodiment of the present invention, when the outside environment is detected to be luminous, the control unit delays the dirtiness level detection and pyrolytic cleaning process for as long as a predetermined period. The dirtiness level detection and pyrolytic cleaning process are provided to be performed in a dark environment and when the energy consumption cost is low.
- [0010] The control unit starts the pyrolytic cleaning process automatically when the dirtiness level increases or enables the user to be alerted.
- [0011] In the oven of the present invention, the dirtiness level inside the oven is detected precisely and safely by means of a light sensor like phototransistor for the pyrolytic cleaning process. Being disposed outside the cooking chamber, the light sensor is not affected from the heat and humidity.
- [0012] The oven realized in order to attain the aim of the present invention is

illustrated in the attached figure, where:

[0013] Figure 1 – is the schematic view of an oven.

[0014] The elements illustrated in the figure are numbered as follows:

1. Oven
2. Body
3. Cooking chamber
4. Heater
5. Door
6. Light source
7. Transparent plate
8. Light sensor
9. Control unit

[0015] The oven (1) comprises a body (2), a cooking chamber (3) disposed within the body (2), wherein the cooking process is performed, a heater (4) that provides pyrolytic cleaning to be implemented by heating the cooking chamber (3) to high temperature values, a door (5) providing access into the cooking chamber (3), produced at least partially from glass and a light source (6) that provides the illumination of the interior of the cooking chamber (3).

[0016] The oven (1) of the present invention comprises a transparent plate (7) disposed on the side or upper wall of the cooking chamber (3) and produced from heat resistant glass, a light sensor (8) that is disposed outside the cooking chamber (3) behind the transparent plate (7) so as to face the interior of the cooking chamber (3) and that detects the light waves emitted from the light source (6) into the cooking chamber (3) and passing through the transparent plate (7), and a control unit (9) that determines the dirtiness level of the cooking chamber (3) by evaluating the light intensity data detected by the light sensor (8).

[0017] The control unit (9) decides that the dirtiness level of the cooking chamber (3) has increased when the amount of light passing through the transparent plate (7) and detected by the light sensor (8) decreases and starts the pyrolytic cleaning process.

[0018] During the utilization of the oven (1), the oil droplets and scraps splattered

from the cooked foods in the cooking chamber (3) adhere to the inner surfaces of the cooking chamber (3) walls and on the surface of the transparent plate (7) facing the cooking chamber (3) as well. The dirt on the transparent plate (7) results in decrease in the intensity of light passing through the transparent plate (7) and detected by the light sensor (8). The control unit (9) determines the dirtiness level of the cooking chamber (3) depending on the amount of decrease in the light intensity detected by the light sensor (8).

- [0019] The control unit (9) compares the light intensity ($I_{m\text{-measured}}$) passing through the transparent plate (7) and detected by the light sensor (8) when the light source (6) is in the open position with the reference light intensity ($I_{m\text{-ref}}$) predetermined when the transparent plate (7) is clean and recorded in its memory and if the difference between the measured light intensity ($I_{m\text{-measured}}$) and the reference light intensity ($I_{m\text{-ref}}$) is greater than the predetermined difference, starts the pyrolytic cleaning process by deciding that the dirtiness level of the cooking chamber (3) has increased.
- [0020] In an embodiment of the present invention, the light sensor (8) is a phototransistor. The phototransistor provides precise measurement even in low light situations.
- [0021] In another embodiment of the present invention, the light sensor (8) is a photodiode. The response time of the photodiode is below 200 ns and the photodiode is used in situations when quick response is desired from the light sensor (8).
- [0022] The control unit (9) first brings the light source (6) to the off position in order to determine the dirtiness level, provides the light sensor (8) to detect whether the oven (1) is located in dark or luminous outside environment and afterwards brings the light source (6) to the open position and applies different dirtiness level measurement algorithms with respect to dark or luminous outside environments and compares the measured light intensity ($I_{m\text{-measured}}$) with different reference light intensities ($I_{m\text{-ref-luminous}}$ or $I_{m\text{-ref-dark}}$) for the dark environment and luminous environment.
- [0023] In an embodiment of the present invention, the control unit (9) determines

the dirtiness level in accordance with a dark environment algorithm prerecorded in its memory when the outside environment is detected to be dark by the light sensor (8) while the light source (6) is in the off position.

[0024] In this embodiment, the control unit (9) provides the illumination of the cooking chamber (3) by activating the light source (6) and compares the intensity of light ($I_{m\text{-measured}}$) passing through the transparent plate (7) with the reference light intensity ($I_{m\text{-ref-dark}}$) for dark outside environment prerecorded in its memory while the light source (6) is open and the transparent plate (7) is clean. The control unit (9) starts the pyrolytic cleaning process by deciding that the dirtiness level of the cooking chamber (3) has increased if the difference between the measured light intensity ($I_{m\text{-measured}}$) and the dark environment reference light intensity ($I_{m\text{-ref-dark}}$) is greater than the predetermined difference.

[0025] In an embodiment of the present invention, the control unit (9) determines the dirtiness level in accordance with a luminous environment algorithm prerecorded in its memory when the outside environment is detected to be luminous by the light sensor (8) while the light source (6) is in the off position.

[0026] In this embodiment, the control unit (9) provides the illumination of the cooking chamber (3) by activating the light source (6) and compares the light intensity ($I_{m\text{-measured}}$) passing through the transparent plate (7) with the reference light intensity ($I_{m\text{-ref-luminous}}$) for luminous outside environment prerecorded in its memory while the light source (6) is open and the transparent plate (7) is clean. The control unit (9) starts the pyrolytic cleaning process by deciding that the dirtiness level of the cooking chamber (3) has increased if the difference between the measured light intensity ($I_{m\text{-measured}}$) and the luminous environment reference light intensity ($I_{m\text{-ref-luminous}}$) is greater than the predetermined difference.

[0027] In another embodiment of the present invention, the control unit (9) delays the detection of dirtiness level and starting of the pyrolytic cleaning process for as long as a predetermined period when the outside environment is detected to be luminous by the light sensor (8).

- [0028] The control unit (9) delays the dirtiness level measurement and the pyrolytic cleaning process for as long as a predetermined period, for example for 12 – 24 hours, when the outside environment is detected to be luminous by means of the light sensor (8) and enables the dirtiness level measurement to be performed in a dark environment. The dirtiness level measurement is preferred to be made in a dark environment especially in order to receive a correct result and since the pyrolytic cleaning process is desired to be performed at times when the electric consumption cost is low.
- [0029] Upon detecting that the outside environment is still luminous at the end of the delay time by means of the light sensor (8), the control unit (9) performs the processes of dirtiness level measurement and the pyrolytic cleaning in accordance with the luminous environment reference values (Im-ref-luminous) recorded in its memory.
- [0030] In an embodiment of the present invention, the control unit (9) starts the pyrolytic cleaning process by automatically operating the heater (4) when the dirtiness level increases.
- [0031] In another embodiment of the present invention, the control unit (9) enables the user to be alerted audibly and/or visually for performing the pyrolytic cleaning when the dirtiness level increases.
- [0032] In the oven (1) of the present invention, the dirtiness level of the cooking chamber (3) is detected precisely by the light source (6) and the light sensor (8) disposed behind a transparent plate (7) facing the cooking chamber (3). The light sensor (8) is not affected by the high temperature and humidity inside the cooking chamber (3) and provides a low cost and safe solution. The light sensor (8) furthermore takes advantage of the cooling provided by means of a fan (F) disposed between the cooking chamber (3) and the upper wall of the body (2) for the front panel (P) whereon the control unit (9), the main control card, the knobs and the screen are located.

Claims

1. An oven (1) **comprising** a body (2), a cooking chamber (3) disposed within the body (2), a heater (4), a door (5) produced at least partially from glass and a light source (6) that provides the illumination of the interior of the cooking chamber (3), **characterized in that** a transparent plate (7) is disposed on the side or upper wall of the cooking chamber (3), a light sensor (8) is disposed outside the cooking chamber (3), behind the transparent plate (7) and detects the light waves emitted from the light source (6) into the cooking chamber (3) and passing through the transparent plate (7), and a control unit (9) determines the dirtiness level of the cooking chamber (3) by evaluating the light intensity data detected by the light sensor (8).
2. The oven (1) as in Claim 1, **characterized in that** the control unit (9) decides that the dirtiness level of the cooking chamber (3) has increased and starts the pyrolytic cleaning process when the amount of light passing through the transparent plate (7), detected by the light sensor (8) decreases.
3. The oven (1) as in Claim 1 or 2, **characterized in that** the control unit (9) compares the light intensity ($I_{m\text{-measured}}$) passing through the transparent plate (7) and detected by the light sensor (8) when the light source (6) is in the open position with the predetermined reference light intensity ($I_{m\text{-ref}}$) recorded in its memory and decides the dirtiness level of the cooking chamber (3) has increased if the difference between the measured light intensity ($I_{m\text{-measured}}$) and the reference light intensity ($I_{m\text{-ref}}$) is greater than the predetermined difference.
4. The oven (1) as in any one of the above claims, **characterized in that** the light sensor (8) is a phototransistor.
5. The oven (1) as in any one of Claims 1 to 3, **characterized in that** the light sensor (8) is a photodiode.
6. The oven (1) as in any one of the above claims, **characterized in that** the control unit (9) compares the light intensity ($I_{m\text{-measured}}$) passing through the transparent plate (7) with the reference light intensity ($I_{m\text{-ref-dark}}$) for dark outside environment prerecorded in its memory by bringing the light source (6) to the open position when the outside environment is detected to be dark by the light sensor (8).

7. The oven (1) as in any one of the Claims 1 to 5, **characterized in that** the control unit (9) compares the light intensity ($I_{m\text{-measured}}$) passing through the transparent plate (7) with the reference light intensity ($I_{m\text{-ref-luminous}}$) for luminous outside environment prerecorded in its memory by bringing the light source (6) to the open position when the outside environment is detected to be luminous by the light sensor (8).
8. The oven (1) as in any one of the Claims 1 to 5, **characterized in that** the control unit (9) delays the dirtiness level detection process and the pyrolytic cleaning process for as long as a predetermined period when the outside environment is detected to be luminous by the light sensor (8).
9. The oven (1) as in any one of the above claims, **characterized in that** the control unit (9) starts the pyrolytic cleaning process by operating the heater (4) when the dirtiness level increases.
10. The oven (1) as in any one of the Claims 1 to 8, **characterized in that** the control unit (9) enables the user to be alerted audibly and/or visually when the dirtiness level increases.

Figure 1

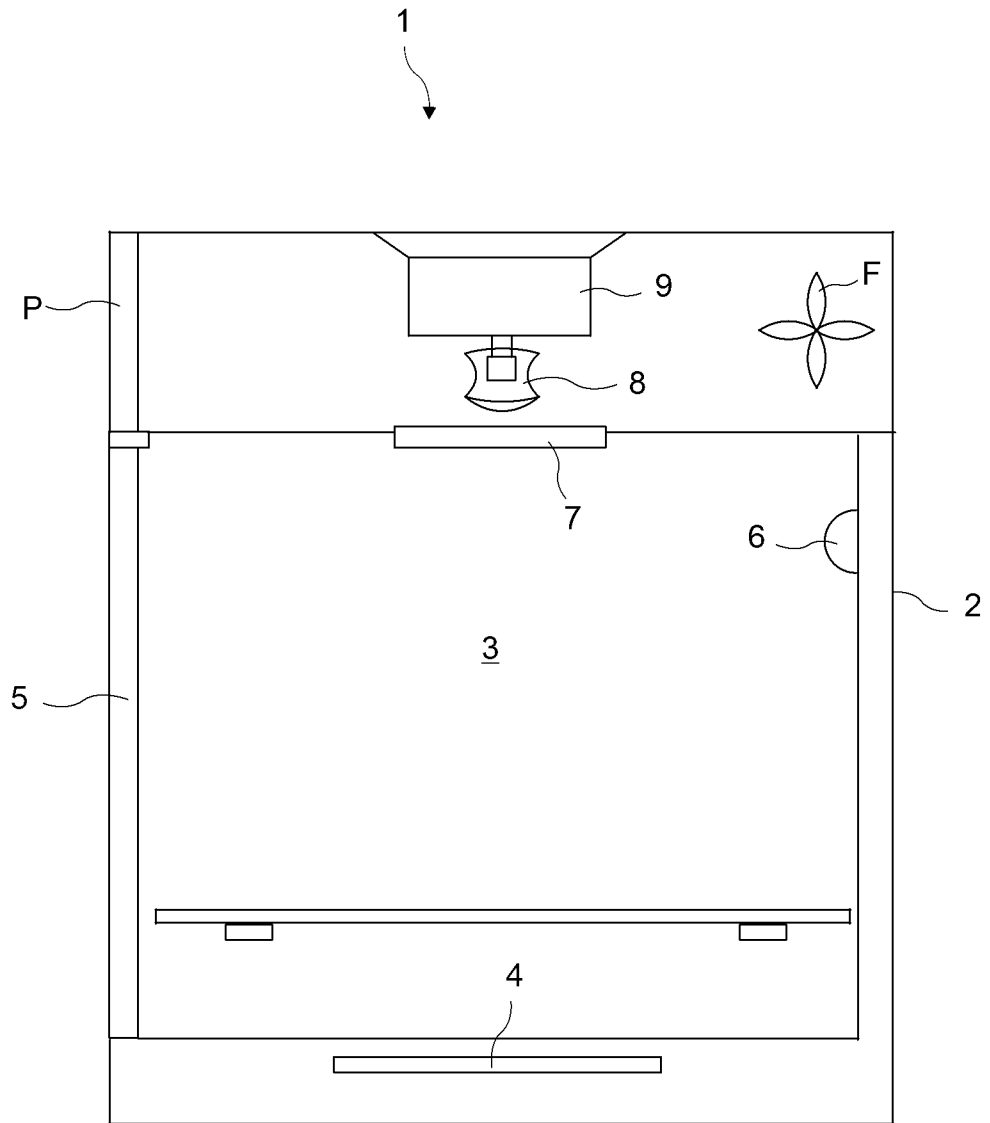

INTERNATIONAL SEARCH REPORT

International application No
PCT/EP2013/076605

A. CLASSIFICATION OF SUBJECT MATTER
INV. F24C15/00 F24C14/02 F24C7/08
ADD.

According to International Patent Classification (IPC) or to both national classification and IPC

B. FIELDS SEARCHED

Minimum documentation searched (classification system followed by classification symbols)
F24C

Documentation searched other than minimum documentation to the extent that such documents are included in the fields searched

Electronic data base consulted during the international search (name of data base and, where practicable, search terms used)

EPO-Internal, WPI Data

C. DOCUMENTS CONSIDERED TO BE RELEVANT

Category*	Citation of document, with indication, where appropriate, of the relevant passages	Relevant to claim No.
X	DE 101 28 024 A1 (BSH BOSCH SIEMENS HAUSGERAETE [DE]) 2 January 2003 (2003-01-02) abstract; figures 1,2 paragraphs [0003] - [0010], [0018], [0021]	1-5,9,10
X	----- KR 2011 0011817 A (LG ELECTRONICS INC [KR]) 9 February 2011 (2011-02-09) paragraphs [0001] - [0011], [0023] - [0027]; figures 1-4	1-3,9
X	----- DE 20 2005 012027 U1 (SINNOTECH ENTWICKLUNGSGESELLSCH [DE]) 23 November 2006 (2006-11-23) paragraphs [0003], [0004], [0012]; figures 1-3	1
	----- -/--	

Further documents are listed in the continuation of Box C.

See patent family annex.

* Special categories of cited documents :

"A" document defining the general state of the art which is not considered to be of particular relevance

"E" earlier application or patent but published on or after the international filing date

"L" document which may throw doubts on priority claim(s) or which is cited to establish the publication date of another citation or other special reason (as specified)

"O" document referring to an oral disclosure, use, exhibition or other means

"P" document published prior to the international filing date but later than the priority date claimed

"T" later document published after the international filing date or priority date and not in conflict with the application but cited to understand the principle or theory underlying the invention

"X" document of particular relevance; the claimed invention cannot be considered novel or cannot be considered to involve an inventive step when the document is taken alone

"Y" document of particular relevance; the claimed invention cannot be considered to involve an inventive step when the document is combined with one or more other such documents, such combination being obvious to a person skilled in the art

"&" document member of the same patent family

Date of the actual completion of the international search	Date of mailing of the international search report
13 May 2014	21/05/2014

Name and mailing address of the ISA/ European Patent Office, P.B. 5818 Patentlaan 2 NL - 2280 HV Rijswijk Tel. (+31-70) 340-2040, Fax: (+31-70) 340-3016	Authorized officer Fest, Gilles
--	--

INTERNATIONAL SEARCH REPORT

International application No
PCT/EP2013/076605

C(Continuation). DOCUMENTS CONSIDERED TO BE RELEVANT		
Category*	Citation of document, with indication, where appropriate, of the relevant passages	Relevant to claim No.
A	JP H05 302726 A (TOSHIBA CORP) 16 November 1993 (1993-11-16) abstract paragraphs [0003], [0008], [0013] -----	1-5,10
A	EP 0 528 250 A2 (BOSCH SIEMENS HAUSGERAETE [DE]) 24 February 1993 (1993-02-24) abstract -----	1,2

INTERNATIONAL SEARCH REPORT

Information on patent family members

International application No

PCT/EP2013/076605

Patent document cited in search report	Publication date	Patent family member(s)	Publication date
DE 10128024	A1	02-01-2003	NONE

KR 20110011817	A	09-02-2011	NONE

DE 202005012027	U1	23-11-2006	NONE

JP H05302726	A	16-11-1993	NONE

EP 0528250	A2	24-02-1993	AT 118083 T 15-02-1995
		DE 4127390 A1	25-02-1993
		EP 0528250 A2	24-02-1993
		ES 2068658 T3	16-04-1995
