



(43) International Publication Date  
2 February 2017 (02.02.2017)

(51) International Patent Classification:

*G01M 3/16* (2006.01)     *B65B 57/10* (2006.01)  
*G01M 3/18* (2006.01)     *B65B 57/18* (2006.01)  
*B21B 39/00* (2006.01)     *B65G 39/00* (2006.01)

(21) International Application Number:

PCT/IB2016/054464

(22) International Filing Date:

26 July 2016 (26.07.2016)

(25) Filing Language:

Italian

(26) Publication Language:

English

(30) Priority Data:

102015000038639 27 July 2015 (27.07.2015) IT

(72) Inventors; and

(71) Applicants : **SGARGI, Leandro** [IT/IT]; Via dell'Osteria 27, 40050 Monterenzio (IT). **FUSTINI, Stefano** [IT/IT]; Via Claterna 42, 40064 Ozzano dell'Emilia (IT). **FINI, Angelo** [IT/IT]; Via Rotta 39, 40132 Bologna (IT).

(81) Designated States (unless otherwise indicated, for every kind of national protection available): AE, AG, AL, AM, AO, AT, AU, AZ, BA, BB, BG, BH, BN, BR, BW, BY, BZ, CA, CH, CL, CN, CO, CR, CU, CZ, DE, DK, DM, DO, DZ, EC, EE, EG, ES, FI, GB, GD, GE, GH, GM, GT,

HN, HR, HU, ID, IL, IN, IR, IS, JP, KE, KG, KN, KP, KR, KZ, LA, LC, LK, LR, LS, LU, LY, MA, MD, ME, MG, MK, MN, MW, MX, MY, MZ, NA, NG, NI, NO, NZ, OM, PA, PE, PG, PH, PL, PT, QA, RO, RS, RU, RW, SA, SC, SD, SE, SG, SK, SL, SM, ST, SV, SY, TH, TJ, TM, TN, TR, TT, TZ, UA, UG, US, UZ, VC, VN, ZA, ZM, ZW.

(84) Designated States (unless otherwise indicated, for every kind of regional protection available): ARIPO (BW, GH, GM, KE, LR, LS, MW, MZ, NA, RW, SD, SL, ST, SZ, TZ, UG, ZM, ZW), Eurasian (AM, AZ, BY, KG, KZ, RU, TJ, TM), European (AL, AT, BE, BG, CH, CY, CZ, DE, DK, EE, ES, FI, FR, GB, GR, HR, HU, IE, IS, IT, LT, LU, LV, MC, MK, MT, NL, NO, PL, PT, RO, RS, SE, SI, SK, SM, TR), OAPI (BF, BJ, CF, CG, CI, CM, GA, GN, GQ, GW, KM, ML, MR, NE, SN, TD, TG).

Declarations under Rule 4.17:

— of inventorship (Rule 4.17(iv))

Published:

— with international search report (Art. 21(3))

— before the expiration of the time limit for amending the claims and to be republished in the event of receipt of amendments (Rule 48.2(h))

(54) Title: SYSTEM FOR THE DETECTION OF LEAKAGES OF LIQUID OR FLUID PRODUCTS CONTAINED IN CONTAINERS INTRODUCED INTO CARDBOARD BOXES CONVEYED ALONG A PACKAGING LINE

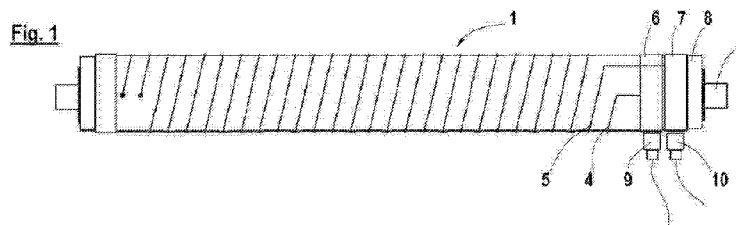

(57) Abstract: The system for detecting leakages of liquid products included in containers introduced into cardboard boxes comprises a sensor roller (1) installed along a packaging line (40) of liquid or fluid products in corresponding containers introduced into cardboard boxes (15), for detecting the presence of a leakage (16) from the products at the bottom of the boxed (15), when the leakage (16) is in a position such as to make a connection between two conductors (4, 5), helically wound along the cylindrical body (2) of the roller. The conductors are connected to a control unit (20). The connection between the conductors (4, 5) and the control unit is obtained via two rings (6, 7) made of conductive material, to which the ends of the conductors (4, 5) are joined and on which two corresponding sliding contacts (9, 10) slide, the rings being connected to the control unit (20). The control unit (20) is linked to ejection means (33) acting on said box (15) having the leakage (16), and/or with stop means (34) of said packaging system (40), and/or with optical warning means (35), and/or acoustic warning means (36).



WO 2017/017614 A1

## **SYSTEM FOR THE DETECTION OF LEAKAGES OF LIQUID OR FLUID PRODUCTS CONTAINED IN CONTAINERS INTRODUCED INTO CARDBOARD BOXES CONVEYED ALONG A PACKAGING LINE**

### **Field of the Invention**

The present invention relates to the packaging field, in particular to packaging of fluid or liquid products with sufficient electrical conductivity into cardboard boxes. In a more detailed way, the present invention relates to a device for detecting leakages, which come out of flasks or bottles containing the fluid or liquid products and affect the bottom of the cardboard boxes, thus damaging it.

### **Description of the Prior Art**

As it is known, beverages in bottles, but also milk and its by-products, dressings and sauces, detergents, lubricators and many other liquid or fluid products with sufficient electrical conductivity, are often sold in containers made of glass, cardboard or plastic, packaged in groups in cardboard boxes.

Packaging of products and the subsequent containers into the cardboard boxes is generally carried out by automated processes and systems, in which the cardboard boxes are moved along roller conveyors to be eventually put onto pallets, that is, picked up one by one from the packaging line, manually or by robotized devices, and stacked orderly on a platform, usually of wood, called pallet, intended for being taken over and conveyed by mechanical means.

When the filled bottles or flasks are introduced into the boxes, sometimes, due to a damage or fault of the container or its incorrect closing, a part of its liquid contents happens to come out, soaking the inner surface of the lower flaps of the box or also the outer part of the bottom, depending on the entity of the leakage.

Depending on the entity of the leakage, different levels of damages can occur. A first level includes only aesthetic damages, in case of leakages of small amounts of liquid, which cause only stains on the bottom seen from outside, or the deformation of the bottom.

On the other hand, leakages of more substantial amounts cause tearing of the box bottom during the transport on the rollers, loss of fragments of material, which can provoke jamming or erroneous detection by the sensors.

Finally, the worst level with leakages of relatively big amounts of liquid can cause quite serious damages, up to breaking a part of the bottom of the box, with the containers going out, when the box is lifted to be placed on the pallet.

In the last cases, the bottom of the box could be knocked out, making all the containers go out.

These disadvantages generally bring the flow of production to a standstill and stop the system, which needs cleaning operations, if not maintenance and/or repair. Suffice it to think about falling of a number of bottles of glass filled with dressing products, e.g. oil, which, once broken, dirty the packaging line, floor, possible control panels situated in the area, etc. causing also hazard situations.

The automation of the packaging line and the speed of the cardboard boxes moving along the conveyors usually do not allow to visually verify the conditions of the boxes, also because, as already said, the whole leaked liquid spills on the bottom of the box, which moves at a very low height level.

Therefore, a system for controlling the conditions of the bottom of the box, becomes desirable or even necessary, so as to prevent the bottom of the box from collapsing and the containers from falling out, causing disastrous effects.

The publication US3938116A describes a device for detecting leakages of containers included in cardboard boxes. Basically, it comprises a sensor plate, which is mounted so as to be an integral part of the normal conveying line of the boxes. Two bars of copper, parallel and spaced out, are embedded in the plate and extend in a direction crosswise to the movement path of the boxes along the conveying line.

Where a leakage of liquid occurs inside one box and the lower part thereof soaks and weakens, when the box passes above the plate, the pair of bars detects the humidity as a consequence of the variation of the resistance present therebetween. Consequently, a suitable control and amplification circuit activates a visual and/or acoustic indicator and stops the machine and palletizer until the damaged box is removed.

Although it is efficacious in its simplicity, the device of the publication US3938116A still presents serious drawbacks. Actually, it can be easily installed on conveyors with sliding surfaces, which transport the boxes dragging them with their bottom, but it is not suitable for roller conveyors.

In addition, if the entity of the leakage is small, the passage itself on the bars of copper, with the relative corners oriented crosswise with respect to the forward movement of the

boxes, can be sufficient to tear the bottom of the box, leaving fragments, which can put at risk the correct operation of the device.

If the leakage is substantial, supposing that the box dragged up to the detecting plate is still at least partially intact, the passage on the corners of the bars of copper can cause the total tearing of the bottom of the box. On the one hand, this thwarts the detection of the leakage and on the other hand makes the production and system stop already in this step.

In addition, the sensitivity of the device is penalized by the relative motion between the box and the detecting bars, therefore the period of time, during which the soak area of the bottom of the box remains between the two bars, thus establishing a connection therebetween, is extremely short and is affected in a determining way by the speed of the forward movement of the boxes.

Another drawback derives from the fact that the two bars of copper tend to wear out due to the friction of the boxes passing above and after some time they are no more able to detect the leakages efficaciously.

The document JP 2008128828 describes a device, which functions as a detector of small leakages that can occur along the welding area of pouches of synthetic plastic material filled with liquid products. The pouches are conveyed along a belt conveying line, along which the sliding surface is interrupted. A pair of rollers is provided at the interruption point. A sensor cable is wound on the surface of the rollers. The pressure between the rollers causes a leakage of a small amount of liquid, if the welding is faulty or if there is a small hole in the welding area. The sensor cable detects the presence of the liquid and the device emits a warning signal.

The device of the publication JP 2008128828 is not suitable for detecting the leakages of containers carried in the cardboard boxes either, because the interruption of the sliding surface creates a stepped area on the path of the products and the bottom of a wet cardboard box could tear in this area. Obviously, it does not happen with pouches of plastic material, which are stronger and not subjected to tearing.

Moreover, this device checks the leakage of the container of the product and not of the box, inside which the containers are held.

### **Summary of the Invention**

Therefore, it is an object of the invention to propose a device for detecting leakages of

liquid or fluid products, with sufficient electrical conductivity, introduced in containers packaged into cardboard boxes. The proposed device is simple and cheap and can be easily integrated with any kind of packaging system and does not damage in any way the bottom of the boxes possibly weakened by a leakage of liquid or fluid from the containers held thereinside. In this way, the box can be removed without further damages thereof with the containers and dirt leaving the conveying line.

Another object of the invention is to propose a device which is extremely sensitive to the detection of the soak areas of the bottom of the boxes, whose sensitivity is not affected, or is affected in a minimum way, by the speed of forward movement of the boxes on the conveyor.

These and other objects which become evident from the following description, are all obtained by a system for detecting leakages of liquid or fluid products included in corresponding containers introduced in cardboard boxes, in which a sensing roller, adapted to be installed along or in proximity to a packaging line of liquid or fluid products included in corresponding containers introduced into cardboard boxes, detects the presence of leakages of said liquid or fluid products, in particular on the bottom of said cardboard boxes, and comprises a cylindrical body, on which two conductors or probes are applied, wound in a spiral and parallel to each other and extending from one end to the other of said cylindrical body, with two ends of the conductors being connected to a control unit by means of rings and respective sliding contacts. When a leakage is detected on the bottom of a box which connects the two conductors, the control unit acts on the packaging line, so as to remove or allow to remove the cardboard box, on the bottom of which the presence of leakages has been detected.

With respect to the publication US3938116A, in the system according to the present invention no scraping occurs on the bottom of the box and consequently, even with a bottom partly damaged by the leakage of the liquid or fluid product, no tears or rips are caused and the containers remain always inside the respective box, until it is removed. Also with respect to the publication JP 2008128828 the system described herein appears new and inventive, since it refers exclusively to cardboard boxes, therefore a person skilled in the art would not look for the solution among the devices relative to pouches of plastic closed by welding. In addition, the boxes on which acts the device proposed by the invention are carried on rollers and not on sliding beds, thus avoiding scrapings and possible tearing.

Also the terminal part of the packaging line distinguishes the invention with respect to the prior art, since the boxes are placed on a pallet in automatic way. The wholeness of the bottom of the box including the containers, and not of the containers, is particularly important. For this reason, the roller passes through the whole lower surface of the bottom of the box, touching it point by point, and not only the closure part, as it occurs in the device of the publication JP 2008128828.

Finally, the presence of the roller below the box is essential, because the leakages of the containers weaken the bottom of the box, which is not visible to the operators. An upper roller would be quite useless and no pressure is applied to the containers to make a small amount of liquid go out.

### **Brief Description of the Drawings**

The characteristics of the invention which do not result from what has been said before, will become evident in the following description, to be considered with reference to the enclosed drawings, in which:

Figure 1 and Figure 2 illustrate the sensing roller proposed by the present invention in two different embodiments, respectively;

Figure 3 illustrates a detail of the sensing roller, seen from below;

Figure 4 illustrates a simplified form of the terminal part of a packaging system of containers into cardboard boxes provided with a palletizer;

Figure 5 is a simplified block diagram of the device proposed by the invention, operatively associated with the system of Figure 4.

### **Detailed Description of the Invention**

With reference to the above mentioned figures, the numeral 1 indicates a sensing roller made in accordance with the invention in a first embodiment (Figure 1), adapted to be installed along or in proximity to a packaging line 40 of liquid or fluid products introduced into containers inside corresponding cardboard boxes 15.

In detail, the sensing roller 1 comprises a cylindrical body 2, preferably tubular, having its ends provided with supports 3 adapted to be rotatably constrained in a known way, along the conveying path of a roller conveyor 31, for example before the palletizer device 30, as illustrated in Figure 4.

The sensing roller 1 could also be installed, always in such a way as to rotate freely,

before the roller conveyor 31 or after it. The latter case can be applied only if there is no palletizer device 30, which automatically withdraws the boxes 15 from the roller conveyor 31, since the boxes are moved manually, as it will become more evident below.

The cylindrical body 2 of the roller 1 has, wound in a spiral thereon, two conductors or probes 4, 5, which extend wrapping the cylindrical body 2 from one of its ends to the other, parallel to each other.

The conductors 4, 5 can be produced in stainless steel. The conductivity of this material is sufficient for an optimal operation of the system and the wear caused by the passage of the boxes is considerably reduced. In addition, the conductors of stainless steel are more resistant to corrosion, even caused by leakages of the packaged products.

The two conductors 4, 5 are connected with one end to respective rings 6, 7, made of conductive material, fixed to one head 8 of the cylindrical body 2 of the roller 1.

The two rings 6, 7 of conductive material, for example copper, are situated in proximity to a head 8 of the cylindrical body 2. Two corresponding sliding contacts 9, 10 press the rings.

According to known techniques, the sliding contacts can be made of brushes of conductive material, such as coal, or of metallic mesh, of the type used for electrical engines.

The sliding contacts 9, 10 in turn are connected to a control unit 20, and being joined to the mentioned ends of the conductors 4, 5, they create their connection with the control unit 20, without obstructing the rotation of the roller 1. The remaining two ends of said conductors 4, 5 are isolated from each other (Figure 1).

The control unit 20 is constructed so as to act on the bottom of a box 15, when a leakage 16 is detected, so as to remove or allow to remove the cardboard box 15, in which the presence of leakages 16 has been detected.

The leakage or leakages 16 are detected, when they are in such a position as to create a connection between the two conductors 4, 5 (Figure 3), connection which is detected by the control unit 20, since it closes the circuit formed by the conductors 4 and 5.

In a second embodiment, the sensing roller 101 (Figure 2) comprises the cylindrical body 102, on which only one conductor 104 is applied, extending from one end to the other of said cylindrical body 102, wound in a spiral on the cylindrical body 102.

In this second embodiment, the ends of the only conductor 104 are connected to two rings 106, 107 of conductive material located each in proximity to a corresponding head

of the cylindrical body 102.

In any case, there is nothing to prevent applying the two rings 106, 107 at only one head, making the head of the conductor 104, situated at the opposite end, pass under the helical extension of the conductor 104 or, preferably, inside the roller 101 thanks to a tubular conformation.

As in the case of the first embodiment, two corresponding sliding contacts 109, 110, press the two rings 106, 107, constituted by carbon brushes or metallic mesh, connected in turn to the control unit 20.

Therefore, the ends of the conductor 104 are thus connected to the control unit 20, without obstructing the rotation of the roller 101.

The control unit 20 is connected with ejecting means 33 of the cited box 15 affected by the leakage 16, for example, formed by a pusher, to which corresponds, in an exemplary and simplified form, an inclined plane 37, on which the box 16, removed from the roller conveyor 31, is made to slide.

The control unit 20 is also connected to stop means 34, adapted to stop operation of the packaging system 40, as well as the optical warning means 35 and acoustic warning means 36.

In detail, the control unit 20 is connected to the control panel of the system 40, leading to ejecting means 33, the stop means 34, optical warning means 35 and acoustic warning means 36, which are operated one by one or in combination depending on the detection of a leakage 16 by the sensing roller 1, 101.

With reference to figures 3, 4 and 5, the operation of the sensing roller 1, 101, installed along the packaging line 40 provided with a palletizer 30 will be now illustrated.

The boxes 15, already filled with containers (not shown) including the liquid or fluid product, are made move forward along the roller conveyor 31 which leads to the palletizer 30.

The forward movement of the boxes is determined by pushing means, not shown herein as known and not relevant to the invention, or due to inertia as a result of the push received in a previous section or pushed each by a subsequent one.

Once the boxes have reached the end of the roller conveyor, the arm 38 of the palletizer 30 picks up the boxes 15 one by one and puts them orderly on a pallet 39.

The roller 1 or 101 is installed in an intermediate position of the roller conveyor 31, as illustrated, but it could be installed upstream of the roller conveyor. It could be situated

also downstream of the roller conveyor 31, if the palletizer did not pick up automatically the boxes, but if there were for example a receiving plane, from which the boxes would be moved manually.

Passing on the roller 1 or 101, the boxes 15 determine the rotation thereof, therefore without any scraping on the bottom of the box, which remains intact in any case. In this way, in any case, the roller passes through the whole lower surface of the bottom of the box 15, touching it point by point.

The detail of Figure 3 shows, in a simplified way, the roller in longitudinal section, ideally transparent and in contact with the bottom of the box 15, all this seen from below.

When a leakage 16, causing a wet stain on the bottom of the box, passes on the roller 1, the stain sets the two conductors 4 and 5 in contact with each other, thus closing the circuit and making the control unit 20 detect the leakage.

The same happens to the roller 101, provided with only one conductor, in this case the connection is created between two or more adjacent coils. The variation of resistance at the ends of the conductor 104 is detected by the control unit 20 by measuring the resistance, and the presence of the leakage on the bottom of the box is determined.

The so generated signal is amplified and processed, and then conveyed to the control panel 32 of the packaging line 40.

Depending on the entity of the detection (resistance value varied in function of the size of the stain caused by the leakage), the control panel determines only the ejection of the box, activating the pusher 33. In more serious cases, in which moving the box could make its bottom collapse and make the containers go out, a stop device 34 of the packaging line is activated.

At this point, an operator acts manually to remove the box, taking care to prevent the containers kept thereinside from going out.

In both cases, the removal of the box or stopping the system can be associated with warning signals, obtained by an optical warning device 35, for example a flashing light, and/or an acoustic warning device 36, for example a beeper, buzzer, bell, horn or the like.

The described system works in an efficacious and effective way also when conducting areas are present on the lower surface of the bottom of the boxes, for example constituted by labels with electrically conductive inks, staples fixing the box flaps, etc. In this case, there can be procedures, which, when the passage of the box has been detected, for example by a photocell, check the duration of the conduction state between

the probes at some later time.

These procedures can be implemented by suitable segments of software programs and possibly known devices, which detect the position of the conductive area, such as laser readers, encoders, other photocells, etc.

The advantageous functionality of the proposed device appears evident.

The system provided with the roller 1 or 101 is able to detect even the smallest leakages of liquid or fluid products with sufficient electrical conductivity, since the conductors 4 and 5 (or the coils of the conductor 104) can be situated very close one to another, making it possible for the smallest stain on the bottom of the box to create the contact.

There is no scraping on the bottom of the box and consequently, even with a bottom partly damaged by the leakage of the liquid or fluid product, no tears or rips are caused and the containers remain always inside the respective box.

The leakage is promptly detected and in the most serious cases, stopping of the packaging line prevents disastrous effects caused by falling of the containers from the torn bottom of the box. If the containers are made of glass, they can break spreading the liquid product on the packaging line, with the risk of failures of the apparatuses and in any case making necessary the cleaning operations which determine long downtimes of the system.

The roller is simple and rapid to be manufactured, consequently it has limited costs and can be installed also on the already functioning systems, by substituting, for example, an idle roller or being applied upstream of a piece of the packaging line.

The conductors are made of stainless steel, therefore they are more resistant to the wear and attacks of corrosive agents, which can be present also among the packaged products. This is a considerable advantage with respect to the conductors of copper, which wear out after a short time and are easily attacked by the corrosive substances. According to very sophisticated versions, the control unit 20 or a part of it could be installed inside the tubular roller, thus eliminating the necessity for the sliding contacts and providing a connection with the remaining part of the control unit or with the control panel of the system in a wireless way, for example Bluetooth or WiFi.

In this case, the energy could be supplied by batteries situated inside the roller, for example rechargeable, possibly connected to a series of windings arranged radial at a head of the roller, with a plurality of fixed magnetic elements opposite thereto. Rotation of the roller produces a voltage at the ends of the windings, and the resulting current,

suitably rectified, filtered and stabilized, can be used for charging the batteries, making the roller wholly autonomous and extremely simple to install.

The system described herein is new and innovative, since it refers exclusively to cardboard boxes, therefore a person skilled in the art would not look for the solution among the devices relative to pouches of plastic closed by welding.

The boxes are conveyed on rollers and not on sliding surfaces, thus preventing scraping and possible tears. There are no teeth or steps along the boxes path.

Also the terminal part of the packaging line distinguishes the invention with respect to the prior art, since the boxes are placed on a pallet in automatic way. The wholeness of the bottom of the box including the containers, and not of the containers, is particularly important. For this reason, the roller passes through the whole lower surface of the bottom of the box, touching it point by point, and not only the closure part, as it occurs in the device of the publication JP 2008128828.

Finally, the presence of the roller below the box is essential, because the leakages of the containers weaken the bottom of the box, which is not visible to the operators. An upper roller would be quite useless and no pressure is applied to the containers to make a small amount of liquid go out.

The teachings of the devices described in the prior art documents do not respond to the needs satisfied by the present invention.

## Claims

1. A system for detecting leakages of liquid or fluid products included in containers introduced into cardboard boxes conveyed along a packaging line, said system comprising a sensing roller, adapted to be installed along or in proximity to a packaging line (40) of liquid or fluid products introduced in corresponding containers into cardboard boxes (15) conveyed along a roller conveyor (31), to detect the presence of leakages (16) of said products on the bottom of said cardboard boxes (15), **characterised in that** said roller comprises a cylindrical body (2), on which are applied two conductors (4, 5) or probes, parallel to each other, which extend from one end to the other of said cylindrical body (2), with two ends of said conductors (4, 5) connected to a control unit (20) adapted to act, when a leak is detected on the bottom (16) of a box (15), so as to remove or allow to remove the cardboard box (15), on the bottom of which the presence of leakages (16) of said products has been detected, and with the remaining two ends of said conductors (4, 5) isolated from each other; with ejecting means (33) of said cardboard box (15) connected to said control unit (20) to eject the cardboard box (15), when a leakage (16) is detected.
2. A system according to claim 1, wherein there are provided two rings (6, 7) of conductive material located in proximity to a head (8) of said cylindrical body (2), with two corresponding sliding contacts (9, 10) pressing thereon, connected to said control unit (20) and which carry, joined thereto, said ends of the conductors (4, 5), which are to be connected to said control unit (20), so as to obtain the connection between said conductors (4, 5), and said control unit (20) allowing the rotation of said roller (1).
3. A system according to claim 1 or 2, wherein said conductors (4, 5) are wound in a spiral and parallel to each other around said cylindrical body (2), extending from a head (8) of the cylindrical body (2) toward the opposite head.
4. A system according to one of the claims 1 to 3, wherein the two conductors (4, 5) are close to each other to detect said leakage (16), which is situated in such a position as to create a connection between them, detected by said control unit (20).
5. A system for detecting leakages of liquid or fluid products included in containers introduced into cardboard boxes conveyed along a packaging line, said system

comprising a sensing roller, adapted to be installed along or in proximity to a packaging line (40) of liquid or fluid products introduced in corresponding containers into cardboard boxes (15) conveyed along a roller conveyor (31), to detect the presence of leakages (16) of said products on the bottom of said cardboard boxes, **characterised in that** said roller comprises a cylindrical body (102), on which a conductor (104) is applied, extending from one end to the other of said cylindrical body (102), with the ends of said conductor (104) connected to a control unit (20) adapted to act, when a leakage (16) is detected on the bottom of a box (15), so as to remove or allow to remove the cardboard box (15), on the bottom of which the presence of leakages (16) of said products has been detected; with ejecting means (33) of said cardboard box (15) connected to said control unit (20) to eject the cardboard box (15), when a leakage (16) is detected.

6. A system according to claim 5, wherein there are provided two rings (106, 107) of conductive material located in proximity to a corresponding head of said cylindrical body (102), with two corresponding sliding contacts (109, 110) pressing thereon, connected to said control unit (20) and which carry, joined thereto, said ends of the conductors (104), which are to be connected to said control unit (20), so as to obtain the connection between said conductor (104) and control unit (20) allowing the rotation of said roller (101).
7. A system according to claim 5 or 6, wherein said conductor (104) is wound in a spiral around said cylindrical body (102), extending from a head of the cylindrical body (102) toward the opposite head.
8. A system according to one of the claims 5 to 7, wherein the coils of said conductor (104) are close one to another to detect said leakage (16), which is situated in such a position as to create a connection between them, detected by said control unit (20).
9. A system according to one or more of the claims 1 to 8, and wherein said ejecting means are manually operated and cooperate with stop means (34) of said packaging line (40), and/or with optical warning means (35), and/or acoustic warning means (36).
10. A system according to one of the preceding claims, wherein said conductors (4, 5) are made of stainless steel.
11. A packaging system (40) of containers including liquid or fluid products and

introduced into cardboard boxes (15), **characterised in that** it includes the system with the sensing roller (1, 101) according to one or more of the claims 1 to 8, and in which said control unit (20) is connected to the control panel of said packaging line (40), to which are connected ejecting means (33) of said box (15) affected by said leakage (16), and/or with stop means (34) of said packaging system (40), and/or with optical warning means (35), and/or acoustic warning means (36), operated one by one or in combination depending on the detection of a leakage (16) by said sensing roller (1, 101).

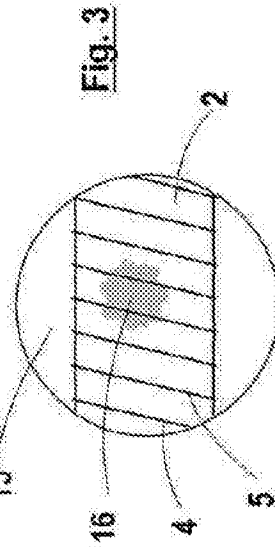
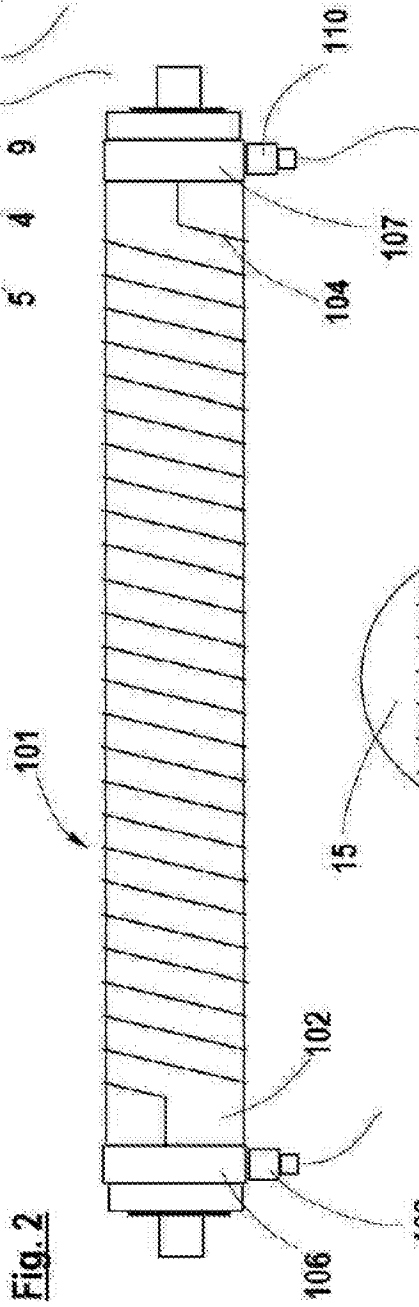
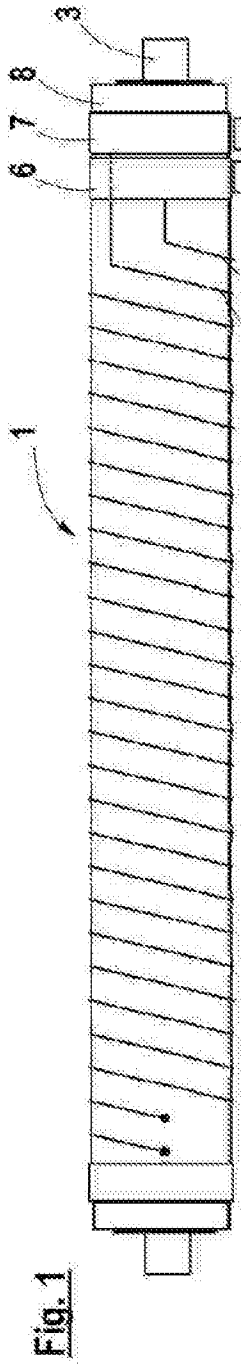

**Fig. 4**

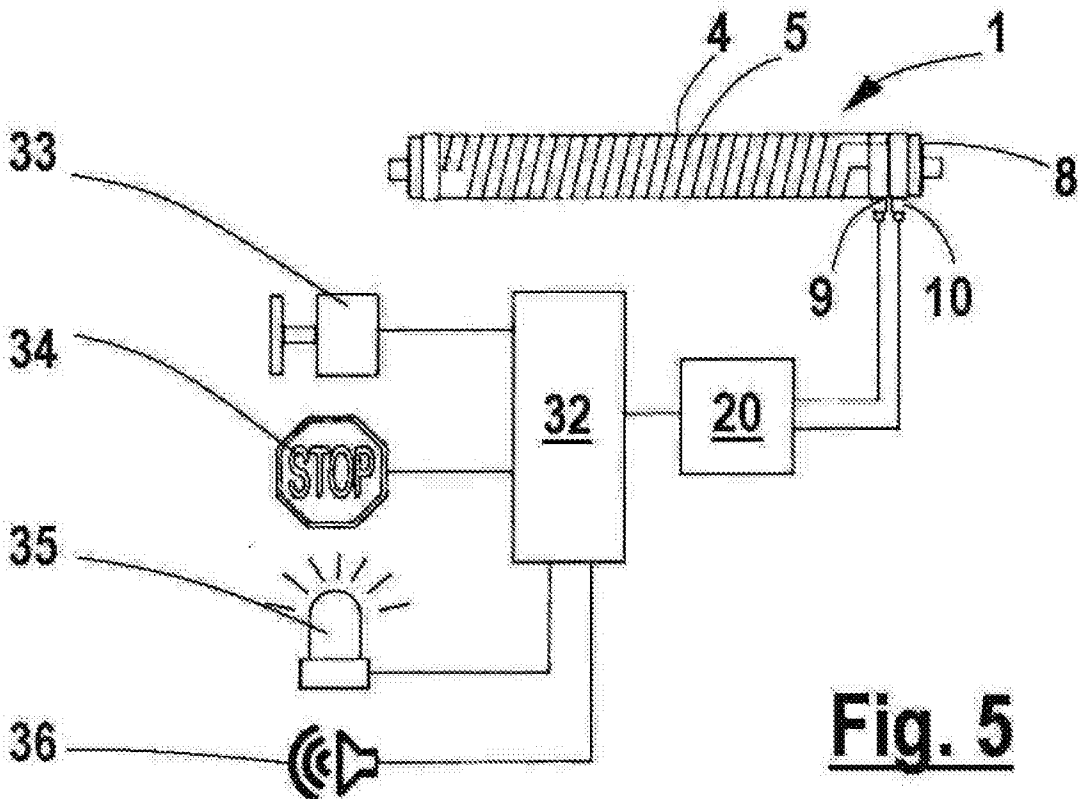
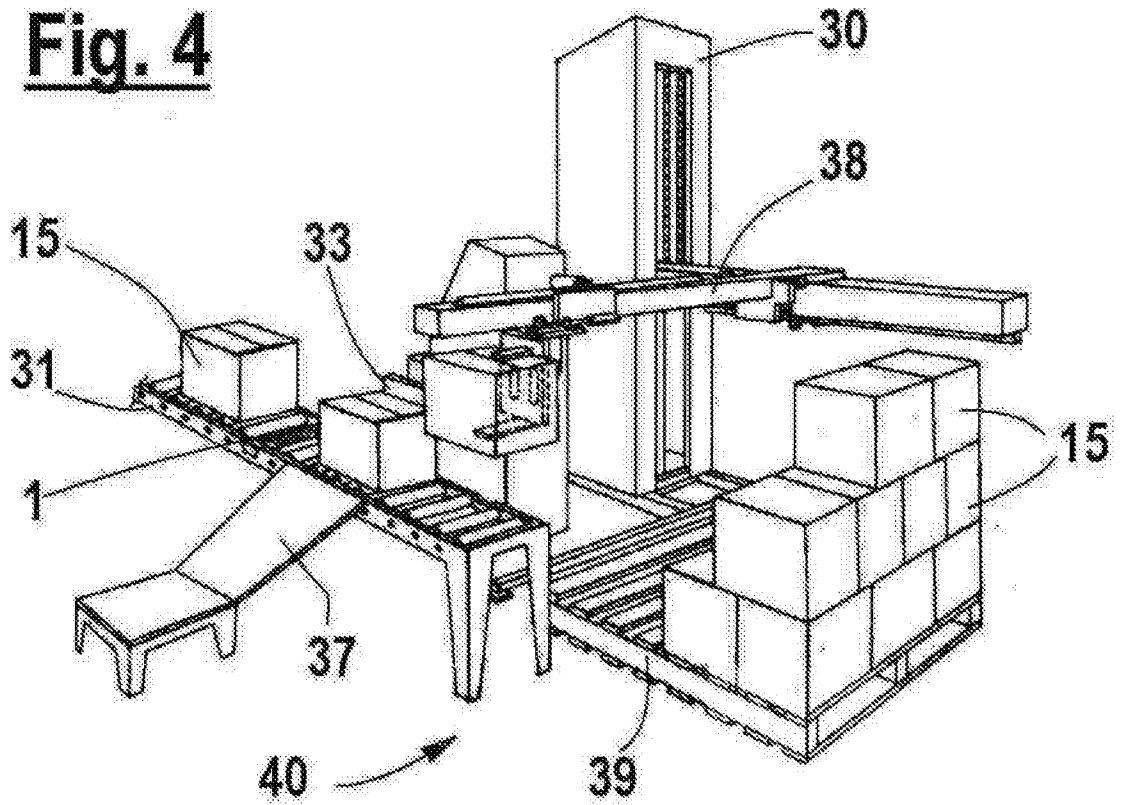

**Fig. 5**

**INTERNATIONAL SEARCH REPORT**

International application No  
PCT/IB2016/054464

**A. CLASSIFICATION OF SUBJECT MATTER**  
 INV. G01M3/16 G01M3/18 B21B39/00 B65B57/10 B65B57/18  
 B65G39/00  
 ADD.  
 According to International Patent Classification (IPC) or to both national classification and IPC

**B. FIELDS SEARCHED**  
 Minimum documentation searched (classification system followed by classification symbols)  
 G01M B21B B65B B65G

Documentation searched other than minimum documentation to the extent that such documents are included in the fields searched

Electronic data base consulted during the international search (name of data base and, where practicable, search terms used)  
 EPO-Internal, WPI Data

**C. DOCUMENTS CONSIDERED TO BE RELEVANT**

Category*	Citation of document, with indication, where appropriate, of the relevant passages	Relevant to claim No.
Y	US 3 938 116 A (SCHNEIDER HELMUT L) 10 February 1976 (1976-02-10) abstract figures 1-4 column 1, lines 19-21 column 2, lines 4-17 -----	1-11
Y	JP 2008 128828 A (LION CORP; YURI KIKAKU KK) 5 June 2008 (2008-06-05) abstract figures 4,5 paragraphs [0028], [0029], [0037], [0038], [0052] -----	1-11
A	US 4 112 417 A (HIMENO YOSHIAKI) 5 September 1978 (1978-09-05) abstract figure 1 -----	5
	-/--	

Further documents are listed in the continuation of Box C.       See patent family annex.

\* Special categories of cited documents :

"A" document defining the general state of the art which is not considered to be of particular relevance	"T" later document published after the international filing date or priority date and not in conflict with the application but cited to understand the principle or theory underlying the invention
"E" earlier application or patent but published on or after the international filing date	"X" document of particular relevance; the claimed invention cannot be considered novel or cannot be considered to involve an inventive step when the document is taken alone
"L" document which may throw doubts on priority claim(s) or which is cited to establish the publication date of another citation or other special reason (as specified)	"Y" document of particular relevance; the claimed invention cannot be considered to involve an inventive step when the document is combined with one or more other such documents, such combination being obvious to a person skilled in the art
"O" document referring to an oral disclosure, use, exhibition or other means	"&" document member of the same patent family
"P" document published prior to the international filing date but later than the priority date claimed	

Date of the actual completion of the international search  11 November 2016	Date of mailing of the international search report  21/11/2016
---	--

Name and mailing address of the ISA/ European Patent Office, P.B. 5818 Patentlaan 2 NL - 2280 HV Rijswijk Tel. (+31-70) 340-2040, Fax: (+31-70) 340-3016	Authorized officer  Nelva-Pasqual, F
--	--

## INTERNATIONAL SEARCH REPORT

International application No  
PCT/IB2016/054464

C(Continuation). DOCUMENTS CONSIDERED TO BE RELEVANT

Category*	Citation of document, with indication, where appropriate, of the relevant passages	Relevant to claim No.
A	US 4 517 827 A (TAPSCOTT DONALD A [CA]) 21 May 1985 (1985-05-21) abstract figures 1,2 column 3, lines 64-67 -----	1-11

# INTERNATIONAL SEARCH REPORT

Information on patent family members

International application No PCT/IB2016/054464
---

Patent document cited in search report	Publication date	Publication date	Patent family member(s)	Publication date
US 3938116      A	10-02-1976	CA	993538 A	20-07-1976
		US	3938116 A	10-02-1976
-----				
JP 2008128828      A	05-06-2008	NONE		
-----				
US 4112417      A	05-09-1978	JP	S57451 B2	06-01-1982
		JP	S5236290 A	19-03-1977
		US	4112417 A	05-09-1978
-----				
US 4517827      A	21-05-1985	CA	1204302 A	13-05-1986
		US	4517827 A	21-05-1985
-----				