

J. H. REED.
 VAMP GREASER.
 APPLICATION FILED JAN. 27, 1908.

996,138.

Patented June 27, 1911.

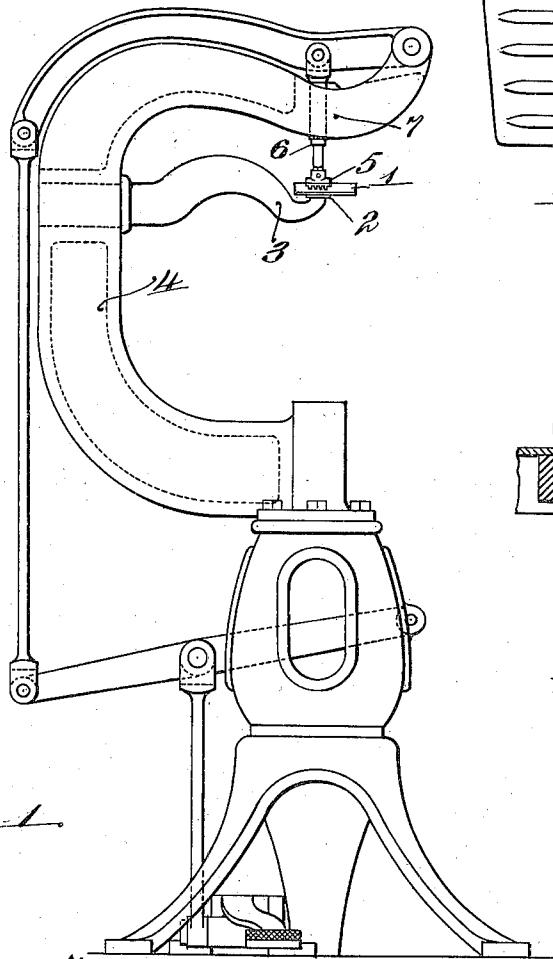

Fig. 1.

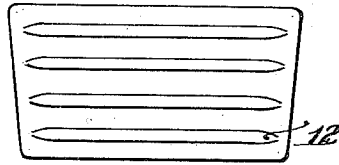

Fig. 5.

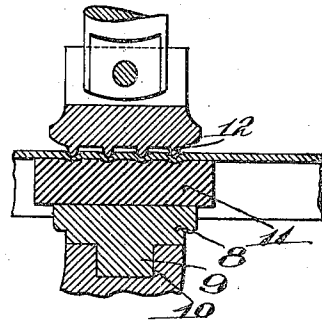

Fig. 4.

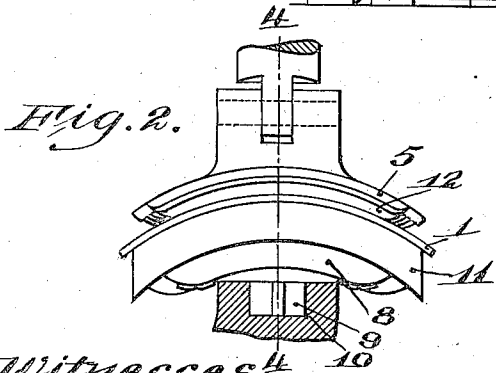

Fig. 2.

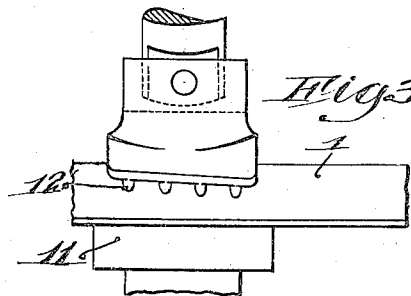

Fig. 3.

Witnesses
 Edward S. Day
 Charles W. McDermott.

Inventor
 James H. Reed
 by his Attorney
 Phillips Van Curen & Fish.

UNITED STATES PATENT OFFICE.

JAMES H. REED, OF SWAMPSCOTT, MASSACHUSETTS, ASSIGNOR TO ESSEX MACHINE COMPANY, OF KITTERY, MAINE, A CORPORATION OF MAINE.

VAMP-CREASER.

996,138.

Specification of Letters Patent. Patented June 27, 1911.
Application filed January 27, 1908. Serial No. 412,758.

To all whom it may concern:

Be it known that I, JAMES H. REED, a citizen of the United States, residing at Swampscott, in the county of Essex and State of Massachusetts, have invented certain new and useful Improvements in Vamp-Creasers; and I do hereby declare the following to be a full, clear, and exact description of the invention, such as will enable others skilled in the art to which it appertains to make and use the same.

The present invention relates to vamp creasers or machines for creasing the uppers of boots and shoes.

On machines heretofore used for creasing boot and shoe uppers a creasing tool is caused to roll over the uppers of the boots and shoes supported upon a horn, the creasing ribs of the tool pressing the leather of the upper into grooves in the horn thereby forming the creases. The creases formed by this machine do not determine to any appreciable extent the location of the wrinkles formed in the upper when the shoe is worn for the reason that if any attempt was made by the operator to form permanent creases deep enough to perform this function by heavily pressing the creasing roll down upon the horn, the upper became cut and consequently ruined. Many manufacturers in creasing the uppers of their shoes use two dies pressing the upper between them, but the creases formed by these dies are too wide to be of any value, and if the ribs of the dies are made closer together to form close creases the upper is liable to be cut. A great many shoes are sold to the dealer without having the creases in the vamp and as the creases add to the appearance of the shoe the dealer often adds the creases to the finished shoe. This operation of forming the creases in a finished shoe necessarily must be performed with great care for if the upper of the finished shoe is cut it means to the dealer the loss of a pair of shoes.

The object of the present invention is to produce an upper creasing machine whereby, without any danger of cutting the upper permanent creases may be imparted to the upper deep enough in extent to positively determine the location of the wrinkles formed when the shoe is worn.

With this object in view the present invention contemplates providing a vamp creasing machine with creasing tools ar-

ranged to cooperate to crease a vamp one of the members having ribs and the other having an inherently elastic vamp engaging portion so that the ribbed member may press the vamp into the elastic portion of the other member thereby performing the creasing operation without any possibility of cutting the upper.

In the accompanying drawings Figure 1 is an end elevation of a vamp creasing machine embodying the invention. Fig. 2 is a side elevation of the vamp creasing tools. Fig. 3 is an end elevation of the vamp creasing tools. Fig. 4 is a cross section on the line 4-4 of Fig. 2 and Fig. 5 is an inverted plan view of one of the creasing tools.

The vamp 1 is placed on a support 2 on the end of an arm 3 projected from the frame 4 of the machine. Cooperating with the support 2 to press the vamp 1 is a ribbed creasing tool 5 fastened to a socket 6 sliding in a sleeve 7 in the frame of the machine. Treadle actuated mechanism for sliding the socket 6 through the sleeve 7 is provided for actuating the creasing tool 5.

The support 2 is constructed in two parts, a metal base 8 provided with a projection 9 fitting into a socket 10 to hold the support firmly on the arm 3.

Attached to the base 8 is a convex rubber piece 11 upon which the vamp rests during the creasing operation. The creasing tool 5 is formed to fit the curve of the rubber 11 and is provided with ribs to engage and crease the vamp. As shown in Figs. 2 and 5 the ribs are successively longer and are arranged in this way so that the longest crease may be formed in that portion of the vamp subjected to the greatest bending which is directly back of the juncture between the toe cap and vamp.

In creasing, the shoe is placed upon the rubber pad of the support, and the treadle is actuated to force the ribbed creasing tool down upon the upper, the pad yielding sufficiently to permit the embedding of the vamp in the rubber, and at the same time preventing any cutting of the vamp during the operation. A spring (not shown) withdraws the ribbed tool from engagement with the vamp to enable the operator to remove the creased shoe and put on another.

It is to be understood that these tools may be used on the vamp before it is made up into a shoe if it is desired so to do.

The principal advantage of this invention is the elimination of the danger of cutting the vamp with failure of registry between creasing tools, another resides in the reduced number of tools required as one pad will cooperate with different styles of ribbed creasing tools.

What is claimed is:—

1. A vamp creasing machine, having, in combination, two vamp creasing tools, one being provided with an inherently elastic support to engage one side of the vamp having a continuous smooth surface capable of yielding at all parts and of sufficient thickness to permit the ribs of the other tool to embed themselves therein, and the other tool being provided with rigid creasing ribs to engage the opposite side of the vamp and means for relatively actuating the tools to cause the ribs to embed the vamp in the body of the elastic support to thereby form creases in the vamp, substantially as described.

2. A vamp creasing machine, having, in combination, a rubber pad to engage one side of the vamp and a tool provided with rigid creasing ribs to engage the other side of the vamp, and means for relatively actuating the pad and tool to cause the ribs to embed the vamp in the body of the elastic support to thereby form creases in the vamp,

the pad being of sufficient thickness to permit the ribs of the tool to embed themselves therein, substantially as described.

3. A vamp creasing machine, having, in combination, a rubber support for the vamp, a tool provided with vamp creasing ribs, and means for relatively actuating the support and tool to cause the creasing ribs to engage the vamp and to simultaneously shape and form all portions of the creases, substantially as described.

4. A vamp creasing machine, having, in combination, a rubber support to engage one side of the vamp, a tool provided with rigid creasing ribs to engage the opposite side of the vamp, and means for relatively actuating the support and tool toward and from each other in a substantially straight line to cause the ribs of the tool, throughout substantially their entire length, to contact simultaneously with the vamp and to embed the vamp in the support to thereby form creases in the vamp, substantially as described.

In testimony whereof I affix my signature, in presence of two witnesses.

JAMES H. REED.

Witnesses:

CHARLES W. McDERMOTT,
MARGARET L. GILMAN.