



US00D766634S

(12) **United States Design Patent** (10) **Patent No.:** **US D766,634 S**  
Nilsson et al. (45) **Date of Patent:** **\*\* Sep. 20, 2016**

(54) **SOLID DRAWER AND DRAWER FRAME**  
(71) Applicant: **Elfa International AB**, Västervik (SE)  
(72) Inventors: **Peter Nilsson**, Västervik (SE); **Sharon Tindell**, Dallas, TX (US)  
(73) Assignee: **Elfa International AB**, Vastervik (SE)  
(\*\*) Term: **15 Years**

D398,151 S \* 9/1998 Ahern, Jr. .... D3/304  
D419,302 S 1/2000 Hardy et al.  
D420,219 S \* 2/2000 Elvin-Jensen ..... D3/304  
D420,799 S \* 2/2000 Douglas ..... D3/304  
D421,183 S \* 2/2000 Koskinen ..... D3/304  
D431,907 S 10/2000 Andujar et al.  
D449,074 S 10/2001 Andujar  
D450,481 S 11/2001 Post

(Continued)

(21) Appl. No.: **29/529,449**  
(22) Filed: **Jun. 8, 2015**  
(51) **LOC (10) Cl.** ..... **06-06**  
(52) **U.S. Cl.**  
USPC ..... **D6/705**  
(58) **Field of Classification Search**  
USPC ..... D6/396-397, 436, 411, 449, 455-469,  
D6/675, 675.1, 705, 705.1; 108/59, 91, 92,  
108/93-94; 211/13.1, 85.1, 85.2, 85.4, 70,  
211/78, 107, 131.1, 133.2, 163, 164, 181.1,  
211/182  
CPC ..... A47B 46/005; A47B 57/10; A47B 46/00  
See application file for complete search history.

FOREIGN PATENT DOCUMENTS

EP 0 176 904 A2 4/1986  
GB 948898 A 11/1962  
WO 2010/121295 A1 10/2010

Primary Examiner — Kelley Donnelly

(74) *Attorney, Agent, or Firm* — Thompson & Knight LLP;  
James J. Murphy; Max Ciccarelli

(57) **CLAIM**

The ornamental design for a solid drawer and drawer frame,  
as shown and described.

**DESCRIPTION**

FIG. 1 is a perspective view of a set of solid drawers and the  
associated drawer frames in an exemplary system shown in  
broken lines;

FIG. 2 is a perspective view of a selected solid drawer and  
associated drawer frame shown in FIG. 1;

FIG. 3 is an elevational view of the front of the solid drawer  
and drawer frame of FIG. 2;

FIG. 4 is an elevational view of a first side of the solid  
drawer and drawer frame of FIG. 2;

FIG. 5 is an elevational view of a second side of the solid  
drawer and drawer frame of FIG. 2; and,

FIG. 6 is a top plan view of the solid drawer and drawer  
frame of FIG. 2.

The broken lines showing is included for the purpose of  
illustrating environment and forms no part of the claimed  
design.

(56) **References Cited**

U.S. PATENT DOCUMENTS

3,087,771 A 4/1963 Pari  
3,379,339 A \* 4/1968 Asenbauer ..... B65D 21/046  
206/506  
3,484,035 A 12/1969 Swett et al.  
3,527,359 A \* 9/1970 Ambertson ..... A47B 31/00  
211/187  
D246,872 S \* 1/1978 White ..... D3/304  
D248,280 S \* 6/1978 Martin ..... D3/304  
D258,721 S \* 3/1981 Steeg ..... D3/307  
4,795,041 A 1/1989 Remmers  
D322,875 S \* 12/1991 Kelley ..... D34/19  
D370,346 S \* 6/1996 Zimmerman ..... D3/314  
D372,123 S \* 7/1996 Kobilarcik ..... D3/312  
D375,836 S \* 11/1996 Conti ..... D3/304

**1 Claim, 6 Drawing Sheets**

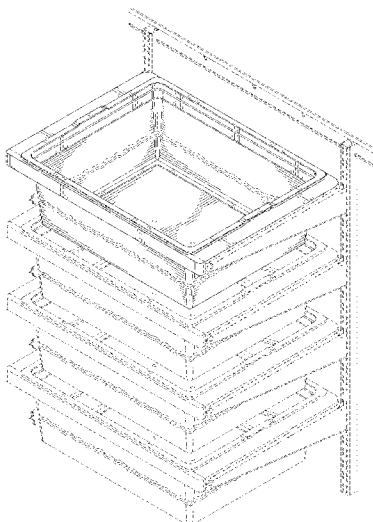

(56)

References Cited

U.S. PATENT DOCUMENTS

D451,675 S	12/2001	Hardy et al.	D584,055 S	1/2009	Hardy et al.	
D453,027 S	1/2002	Andujar	D627,562 S *	11/2010	Osiecki .....	D3/304
D476,155 S	6/2003	Post et al.	D632,080 S	2/2011	Hardy et al.	
D481,233 S	10/2003	Post et al.	D639,561 S	6/2011	Hardy et al.	
D486,981 S	2/2004	Post et al.	D643,628 S *	8/2011	Monarch .....	D3/302
D488,334 S	4/2004	Post et al.	D653,063 S	1/2012	Post et al.	
6,718,635 B2	4/2004	Cheng et al.	D654,690 S *	2/2012	Sofy .....	D3/309
D498,375 S	11/2004	Post et al.	D657,591 S *	4/2012	Sanchez .....	D6/675.1
D501,105 S	1/2005	Post et al.	D681,334 S *	5/2013	Goodell .....	D3/312
D503,059 S	3/2005	Post et al.	D685,994 S *	7/2013	Chen .....	D3/311
D513,874 S	1/2006	Hardy et al.	D730,957 S *	6/2015	You .....	D15/91
D516,347 S	3/2006	Post et al.	D739,691 S *	9/2015	de Groot .....	D7/698
D516,814 S	3/2006	Post et al.	D745,298 S *	12/2015	Workman .....	D6/705
D528,300 S	9/2006	Hardy et al.	D748,916 S *	2/2016	Nilsson .....	D3/302
D530,517 S	10/2006	Hardy et al.	2003/0102315 A1	6/2003	Cheng et al.	
D540,039 S *	4/2007	van Beuningen .....	2005/0077299 A1	4/2005	Cheng et al.	
D549,454 S *	8/2007	Åhman .....	2007/0069542 A1 *	3/2007	Steiger .....	B60P 3/14 296/24.44
7,270,245 B2	9/2007	Cheng et al.	2007/0145865 A1 *	6/2007	Richter .....	A47B 47/025 312/111
D554,896 S	11/2007	Post	2007/0187277 A1	8/2007	Furlong	
D565,334 S	4/2008	Post et al.	2012/0168433 A1	7/2012	Cheng et al.	
D567,553 S	4/2008	Post et al.	2013/0063012 A1 *	3/2013	Lu .....	B62B 3/005 312/334.7
D582,161 S	12/2008	Hardy et al.	2014/0042113 A1	2/2014	Cheng et al.	

\* cited by examiner

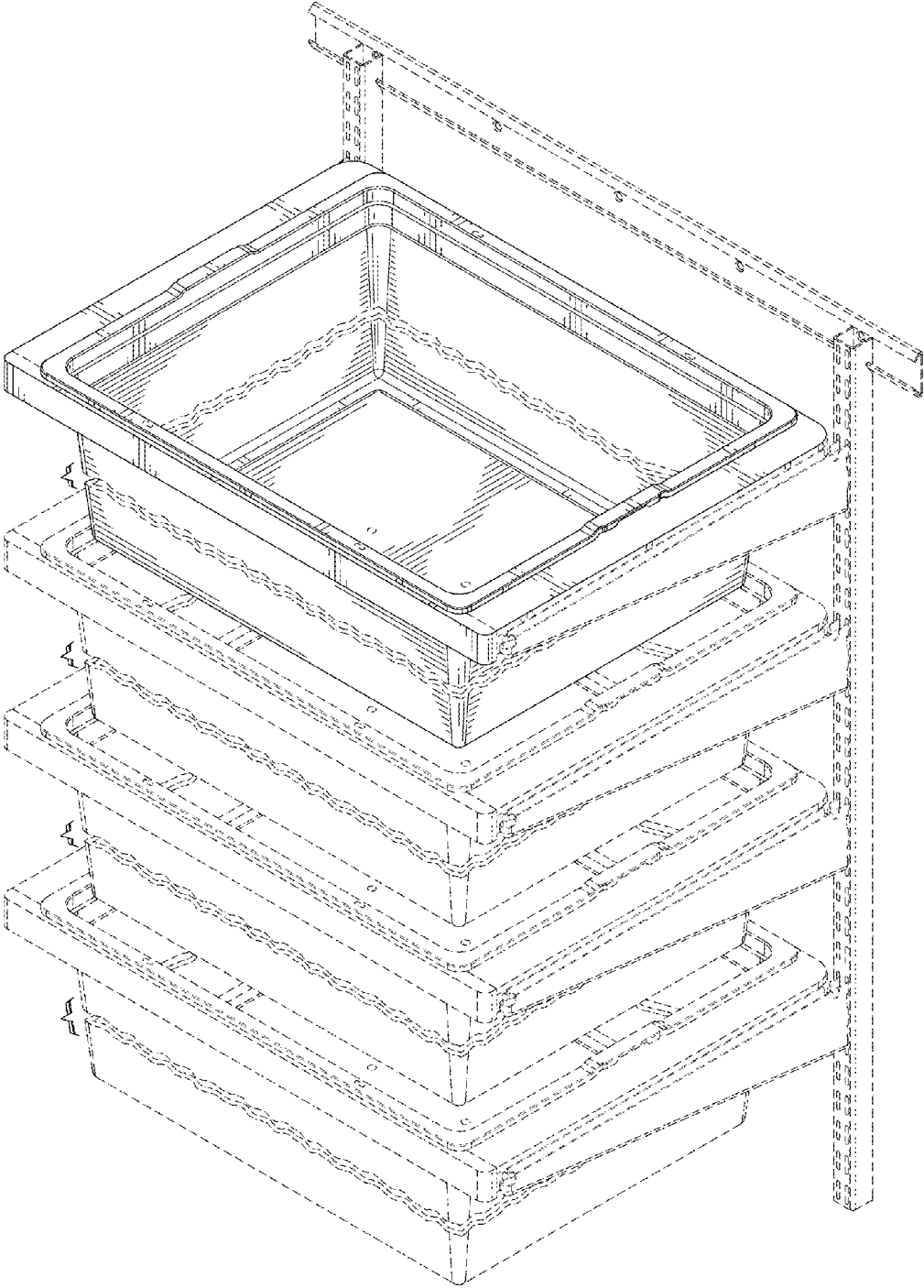

FIG. 1

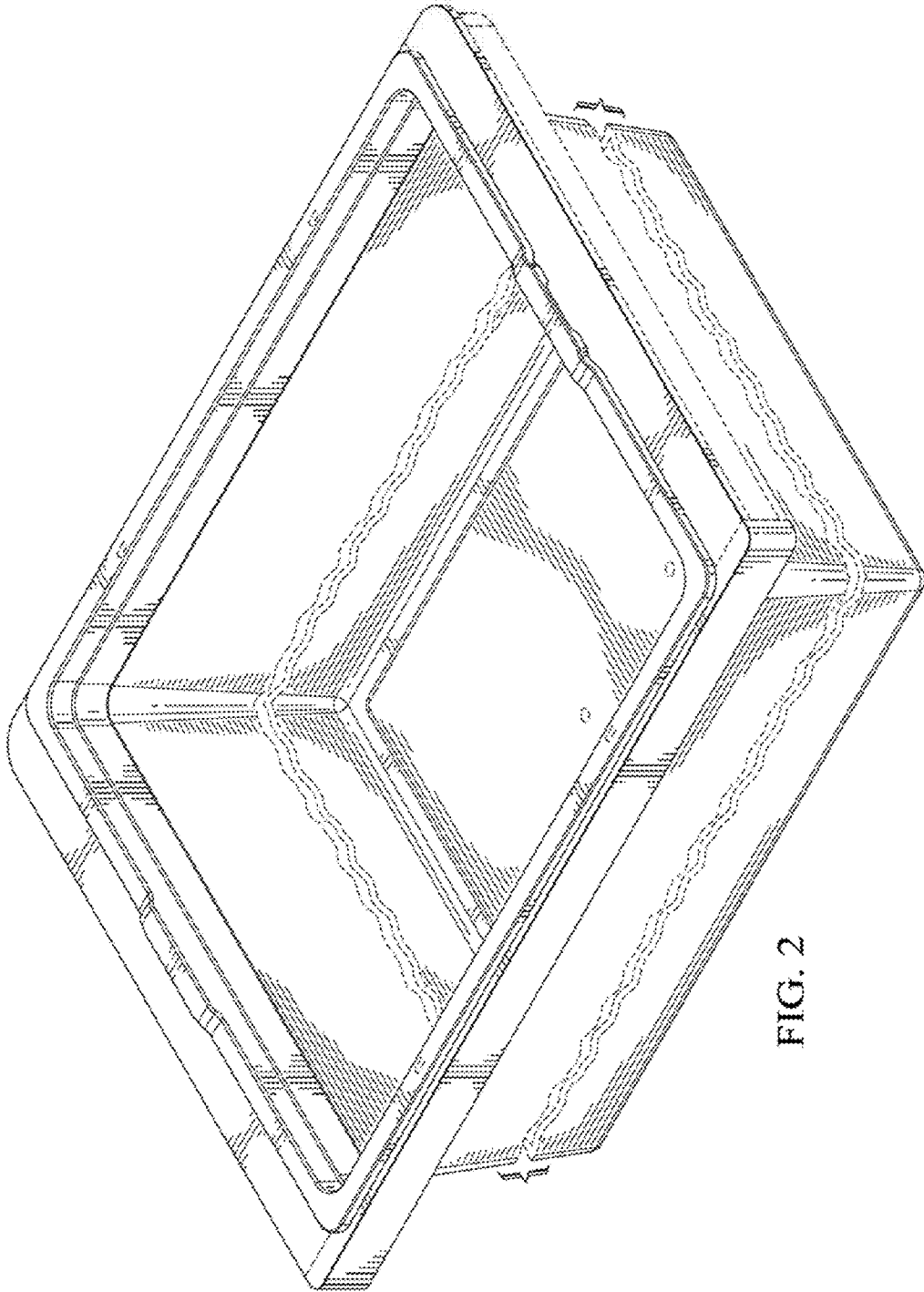

FIG. 2

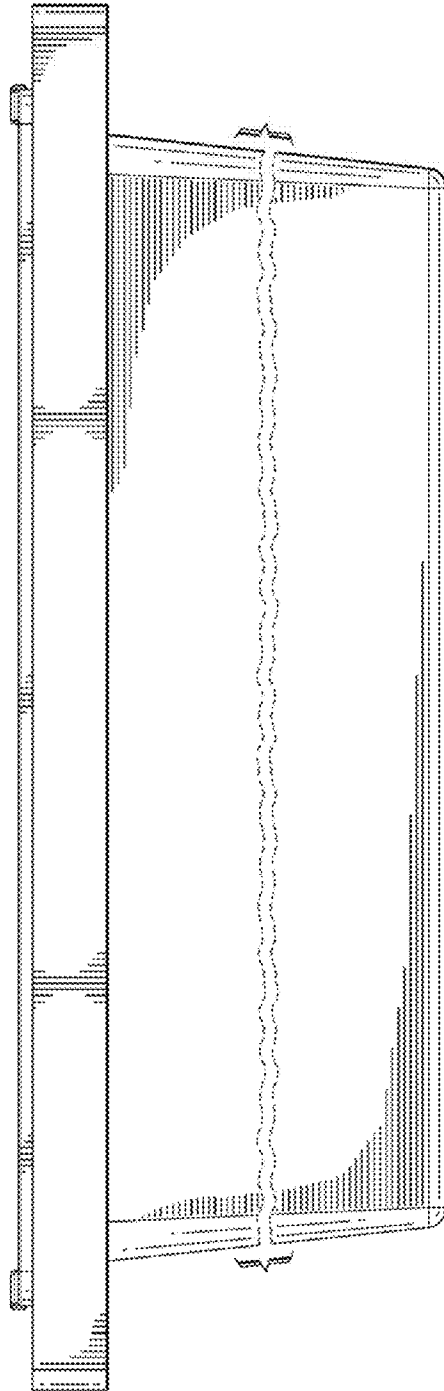

FIG. 3

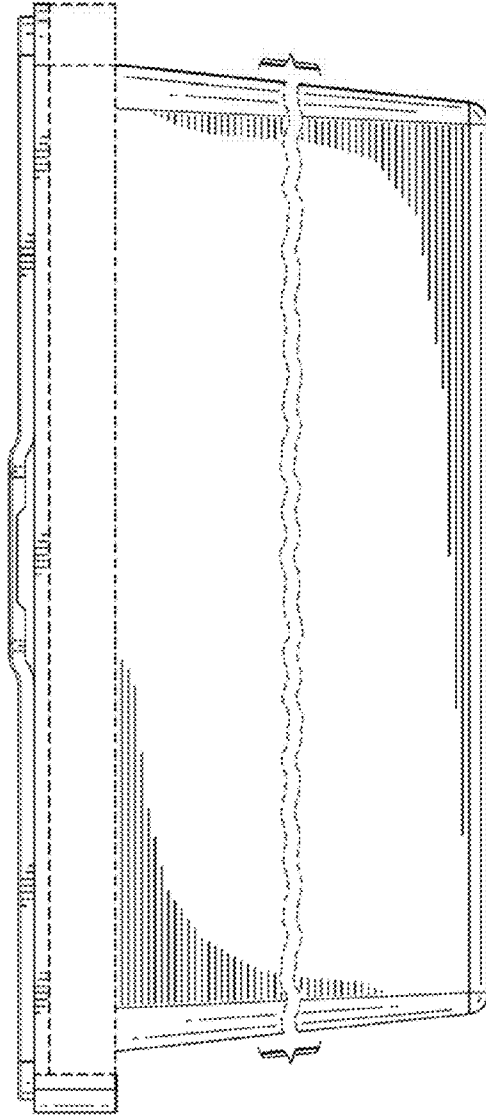

FIG. 4

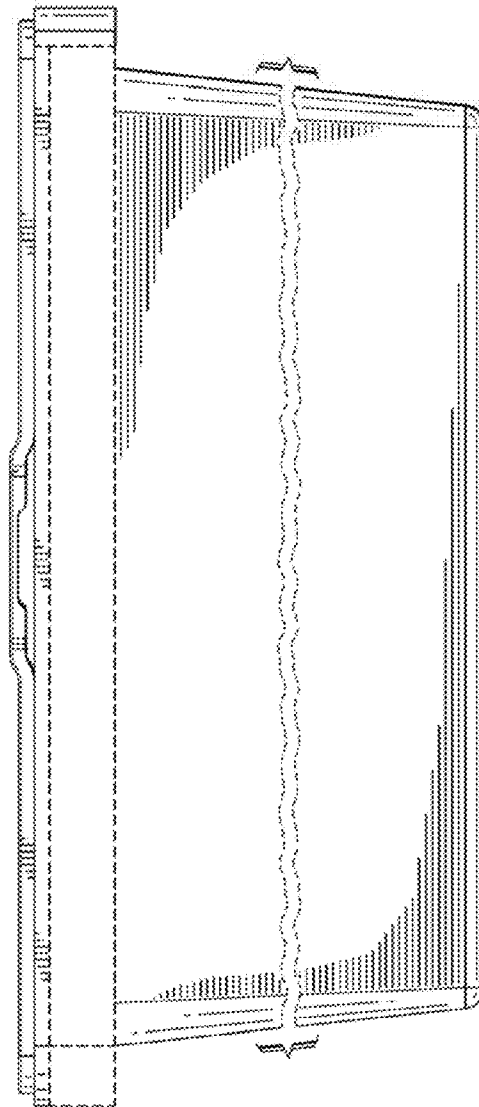

FIG. 5

FIG. 6

