



INTERNATIONAL APPLICATION PUBLISHED UNDER THE PATENT COOPERATION TREATY (PCT)

<p>(51) International Patent Classification <sup>6</sup> : <b>H01R 31/08</b></p>	<p><b>A1</b></p>	<p>(11) International Publication Number: <b>WO 98/09355</b> (43) International Publication Date: 5 March 1998 (05.03.98)</p>
<p>(21) International Application Number: PCT/US97/14728 (22) International Filing Date: 21 August 1997 (21.08.97) (30) Priority Data: 08/703,990 28 August 1996 (28.08.96) US (71) Applicant: THOMAS &amp; BETTS INTERNATIONAL, INC. [US/US]; 1555 Lynnfield Road, Memphis, TN 38119 (US). (72) Inventor: GAUKER, Bradford, K.; 20375 Villa Grande Circle, Clinton Township, MI 48038 (US). (74) Agents: SCHURGIN, Stanley, M. et al.; Weingarten, Schurgin, Gagnebin &amp; Hayes LLP, Ten Post Office Square, Boston, MA 02109 (US).</p>		<p>(81) Designated States: CA, JP, MX, European patent (AT, BE, CH, DE, DK, ES, FI, FR, GB, GR, IE, IT, LU, MC, NL, PT, SE).  <b>Published</b> <i>With international search report.</i></p>

(54) Title: SQUIB CONNECTOR SOCKET ASSEMBLY HAVING SHORTING CLIP FOR AUTOMOTIVE AIR BAGS

(57) Abstract

A squib connector socket assembly (20) for automotive air bags includes a shorting clip assembly (14). The squib connector socket assembly holds a pair of igniter pins (22) of a squib assembly which are connectable to a pair of terminals in a squib connector which plugs into the socket assembly. To prevent accidental firing when the squib connector is removed, the igniter pins are shorted by a shorting clip (18) having a pair of resilient, bowed beams which are independently biased into contact with the pins. The shorting clip is fixedly retained within a plastic socket insert (16). The socket insert (16) and squib assembly are assembled within a metal socket which is roll crimped about the insert and squib assembly to form an inseparable, integral squib connector socket assembly.

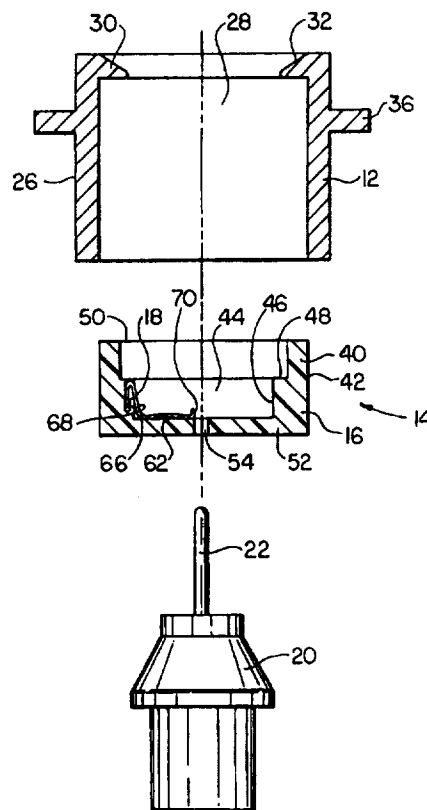

**FOR THE PURPOSES OF INFORMATION ONLY**

Codes used to identify States party to the PCT on the front pages of pamphlets publishing international applications under the PCT.

<b>AL</b>	Albania	<b>ES</b>	Spain	<b>LS</b>	Lesotho	<b>SI</b>	Slovenia
<b>AM</b>	Armenia	<b>FI</b>	Finland	<b>LT</b>	Lithuania	<b>SK</b>	Slovakia
<b>AT</b>	Austria	<b>FR</b>	France	<b>LU</b>	Luxembourg	<b>SN</b>	Senegal
<b>AU</b>	Australia	<b>GA</b>	Gabon	<b>LV</b>	Latvia	<b>SZ</b>	Swaziland
<b>AZ</b>	Azerbaijan	<b>GB</b>	United Kingdom	<b>MC</b>	Monaco	<b>TD</b>	Chad
<b>BA</b>	Bosnia and Herzegovina	<b>GE</b>	Georgia	<b>MD</b>	Republic of Moldova	<b>TG</b>	Togo
<b>BB</b>	Barbados	<b>GH</b>	Ghana	<b>MG</b>	Madagascar	<b>TJ</b>	Tajikistan
<b>BE</b>	Belgium	<b>GN</b>	Guinea	<b>MK</b>	The former Yugoslav Republic of Macedonia	<b>TM</b>	Turkmenistan
<b>BF</b>	Burkina Faso	<b>GR</b>	Greece			<b>TR</b>	Turkey
<b>BG</b>	Bulgaria	<b>HU</b>	Hungary	<b>ML</b>	Mali	<b>TT</b>	Trinidad and Tobago
<b>BJ</b>	Benin	<b>IE</b>	Ireland	<b>MN</b>	Mongolia	<b>UA</b>	Ukraine
<b>BR</b>	Brazil	<b>IL</b>	Israel	<b>MR</b>	Mauritania	<b>UG</b>	Uganda
<b>BY</b>	Belarus	<b>IS</b>	Iceland	<b>MW</b>	Malawi	<b>US</b>	United States of America
<b>CA</b>	Canada	<b>IT</b>	Italy	<b>MX</b>	Mexico	<b>UZ</b>	Uzbekistan
<b>CF</b>	Central African Republic	<b>JP</b>	Japan	<b>NE</b>	Niger	<b>VN</b>	Viet Nam
<b>CG</b>	Congo	<b>KE</b>	Kenya	<b>NL</b>	Netherlands	<b>YU</b>	Yugoslavia
<b>CH</b>	Switzerland	<b>KG</b>	Kyrgyzstan	<b>NO</b>	Norway	<b>ZW</b>	Zimbabwe
<b>CI</b>	Côte d'Ivoire	<b>KP</b>	Democratic People's Republic of Korea	<b>NZ</b>	New Zealand		
<b>CM</b>	Cameroon			<b>PL</b>	Poland		
<b>CN</b>	China	<b>KR</b>	Republic of Korea	<b>PT</b>	Portugal		
<b>CU</b>	Cuba	<b>KZ</b>	Kazakstan	<b>RO</b>	Romania		
<b>CZ</b>	Czech Republic	<b>LC</b>	Saint Lucia	<b>RU</b>	Russian Federation		
<b>DE</b>	Germany	<b>LI</b>	Liechtenstein	<b>SD</b>	Sudan		
<b>DK</b>	Denmark	<b>LK</b>	Sri Lanka	<b>SE</b>	Sweden		
<b>EE</b>	Estonia	<b>LR</b>	Liberia	<b>SG</b>	Singapore		

- 1 -

**SQUIB CONNECTOR SOCKET ASSEMBLY HAVING SHORTING CLIP  
FOR AUTOMOTIVE AIR BAGS**

5

FIELD OF THE INVENTION

This invention relates to the field of automotive air bags and more particularly to squib connectors for automotive air bags.

10

BACKGROUND OF THE INVENTION

Supplemental inflatable restraints or air bag assemblies are becoming increasingly common as a safety device in vehicles throughout the world. The assembly comprises an inflatable canister located in the steering column, the passenger-side dashboard, or the side door panel. Upon a sufficiently great deceleration, the canister is inflated by an explosive device known as a squib which contains a gun powder-based material. The squib is fired electronically upon an electrical signal sent via wires from a deceleration or other sensor in the vehicle. The wires are attached to the squib via a squib connector which plugs into a receptacle or inflator socket in the squib assembly.

15

20

A common form of squib has two pins which extend within the socket, and an associated connector has two terminals which are in electrical contact with the pins when the connector is plugged into the socket. When the connector is removed from the socket, typically for servicing, a shorting clip or shunt is biased into electrical contact with the two pins to form an electrical connection therebetween to reduce the risk of misfiring, for example, by static electricity. The connector urges the shorting clip out of electrical contact with the pins when the connector is plugged into the socket.

25

30

35

In a common prior art squib connector socket assembly, the socket is machined from aluminum and has a machined

- 2 -

opening therein to receive the squib assembly and connector. However, machining is prone to depositing metal burrs and shavings in the socket, which can increase the risk of accidental firing. Additionally, it can be difficult to meet the required dimensional tolerances with machining. This socket assembly is also relatively expensive to manufacture. Further prior art squib connector and shorting clip assemblies are shown in U.S. Patents Nos. 5,275,575, 5,401,180, and 5,435,754.

#### SUMMARY OF THE INVENTION

The present invention provides a squib connector socket assembly including a shorting clip which eliminates the problems of metal burrs, is dimensionally stable, and can be economically manufactured in high volume and low cost. The squib connector socket assembly includes a metal inflator socket and a shorting clip assembly. The shorting clip assembly includes a shorting clip fixedly disposed inside a plastic socket insert. The plastic socket insert can be readily injection molded at low cost and high volume, does not generate metal burrs, and is dimensionally stable. The inflator socket can be impact or cold head extruded, also at low cost and high speed.

The shorting clip, formed of a resilient, electrically conductive material, includes two beams which are biased into contact with the pins of a squib assembly. The beams are able to act independently to make contact with the pins even if the pins are not parallel.

In assembly, the pins of the squib assembly are inserted into openings in the base of the plastic socket insert. The squib assembly and plastic insert are placed in the socket, and the socket is crimped around the insert and squib assembly to retain them within the socket in an inseparable, integral final assembly. When a squib connector is plugged into the socket, the connector urges the beams of the shorting clip out of electrical contact with the pins. When

- 3 -

the squib connector is unplugged from the socket, the resilience of the shorting clip biases the beams back into contact with the pins.

5

#### DESCRIPTION OF THE DRAWINGS

The invention will be more fully understood from the following detailed description taken in conjunction with the accompanying drawings in which:

10

Fig. 1 is an exploded view of a squib connector socket assembly according to the present invention;

Fig. 2 is a top plan view of the squib connector socket assembly of Fig. 1 in an assembled configuration;

Fig. 3 is a cross-sectional side view taken along line A-A of Fig. 2; and

15

Fig. 4 is a cross-sectional side view taken along line B-B of Fig. 2.

#### DETAILED DESCRIPTION OF THE INVENTION

20

The squib connector socket assembly of the present invention includes an inflator socket 12 and a shorting clip assembly 14 for use with inflation canisters of driver's side, passenger side, or side door air bags. The shorting clip assembly 14 includes a socket insert 16 which fits within the inflator socket 12, and a shorting clip 18 fixedly disposed inside the socket insert. In the assembled configuration, a squib assembly 20 having a pair of igniter pins 22 is received in the socket insert 16, and the inflator socket 12 is roll crimped about the socket insert 16 and the squib assembly 20 to form an integral squib and socket assembly, best seen in Figs. 3 and 4. The squib assembly may be any two-pin squib assembly as would be known in the art.

25

30

35

In the unassembled configuration, shown more particularly in Fig. 1, the inflator socket 12 is generally tubular, having a cylindrical exterior surface 26 and an interior space 28 for receiving the socket insert. An interiorly facing annular lip 30 is provided along an upper

- 4 -

end of the socket to retain the socket insert therein. The lip may have a slope 32 on an exterior surface thereof to ease entry of a squib connector (not shown) into the socket assembly. Cut outs 34, shown in Fig. 2, may also be provided in the lip 30 for orientation of the squib connector. The inflator socket 12 is formed of aluminum, stainless steel, or other suitable metal, preferably by an impact or cold headed extrusion process, although other processes may be used. An annular flange 36 or other suitable structure may be formed, as by welding or roll forming, around the exterior of the inflator socket for fastening the socket to an air bag assembly.

The socket insert 16 is generally formed of a plastic material such as a nylon, polybutylene terephthalate (PBT), acetal, polyphenylene sulfide (PPS), liquid crystal polymer (LCP), or other suitable material, preferably by an injection molding process, although other processes may be used. The insert has a side wall 40 having a cylindrical exterior surface 42 with an outer diameter corresponding to the inner diameter of the cylindrical interior space 28 of the inflator socket 12. The insert includes an interior section 44 defined by the interior surface 46 of the side wall. As shown, the side wall interior surface 46 is cylindrical, although other interior surface configurations, such as one or more flat surfaces, may be provided. The interior of the side wall may include a lip or shoulder 48 for receiving a latching mechanism of a squib connector (not shown). The insert 16 is open on one end 50 for receiving the squib connector. The insert further includes a bottom wall 52 on the end opposite the open end. Two openings 54 are formed in the bottom wall which are sized and spaced to receive the pins 22 of the squib assembly 20.

The shorting clip 18 is formed of a resilient, electrically conductive material such as a beryllium-copper alloy. The clip is formed from a single piece of a generally rectangular configuration having a U-shaped cut-out 60 in one

- 5 -

portion to form two beams 62. A bend 66 transverse to the length of the beams is formed slightly beyond the base of the beams to define an upstanding member 68. The angle between the beams 62 and the upstanding member 68 formed by the bend 66 is slightly greater than 90°, as discussed further below.

In assembly, the clip 18 is placed in the insert 16 with the beams 62 extending along the bottom wall 52 of the insert and the upper edge of the upstanding member 68 placed against and fixedly attached, as by stitching, to the interior of the wall 40. Alternatively, the clip can be over molded into the insert. The upstanding member 68 may be curved, at least along an upper portion thereof, to conform to the curvature of the interior surface 46 of the insert. Alternatively, the interior surface may be provided with a flat surface adjacent the clip. Since the angle between the beams and the upstanding member is greater than 90°, the upstanding member diverges from the interior wall toward the bottom wall by a small angle, as best seen in Figs. 1 and 4.

The beams include lips 70 on the outer ends thereof to contact the pins 22 of the squib assembly 20 when inserted through the holes 54 in the insert 16. A stripe of an electrically conductive material such as gold is preferably plated on the lips to provide good electrical contact with the pins. Other conductive materials, such as silver, palladium, or silver/palladium alloys, which can be plated or otherwise suitably deposited onto the lips can be used. The lips 70 may be curved to wrap around the pins 22, thereby ensuring at least two points of contact between the lips and the pins. The ends of the lips are angled slightly away from the pins to allow a squib connector to fit between the beams 62 and the pins 22, thereby providing a dielectric insulation between beams 62 and pins 22.

Each beam 62 is formed with a slight bow along its length such that the beams rest along the bottom wall 52 at a point near the bend 66 and at a point near the lip 70, best seen in Figs. 1 and 4. The length of the beam 62 and the

- 6 -

location of the bend forming the lip 70 are chosen such that, in the unconstrained position, when no igniter pin 22 is inserted in the socket, the bend forming the lip 70 lies at or slightly over the opening 54 in the bottom wall 52 of the insert 16. In this manner, when an igniter pin 22 is present in the socket, the pin 22 exerts a compressive force on the beam 62 tending to push the beam toward the cylindrical wall 40 of the socket insert 16. Since the clip 18 is fixed to the insert 16, this compressive force tends to further bow the beam 62. The resistance of the bow causes the beam to be biased into contact with the pin, thereby maintaining good electrical contact. Furthermore, the two beams act independently, such that one beam can be bowed more than the other beam if, for example, the igniter pins of the squib assembly are not parallel. In addition, as noted above, the bend between the upstanding member 68 and the beams 62 is slightly greater than 90°. When a connector is pushed into the insert 16, the beam is pushed toward the cylindrical wall 40, the bend is reduced slightly and the upstanding member 68 is pushed closer to the wall 40 of the insert 16. The clip 18 moves outward toward the wall 40 of the insert 16, pulling the two beams 62 away from the pins 22. The angle of the bend 66 between the beams 62 and the upstanding member 68 is generally 10°; the exact angle can be readily chosen by one skilled in the art to achieve the desired biasing effect.

When a squib connector (not shown) is inserted into the socket 12 through the opening, the connector is able to fit between the lips 70 of the beams 62 and the pins 22 providing a dielectric insulation between the beams 62 and the pins 22. When the connector is removed, the resilience of the bowed beams and the bend between the beams and the upstanding member bias the beams back into contact with the pins.

The shorting clip is useful for preventing accidental firing of an air bag during servicing when a mechanic removes the connector. Such accidental firing may be caused, for

- 7 -

example, by static electricity. However, some squib assemblies are not intended to be serviced, and in such cases the squib connector is not removable by a mechanic. A shorting clip is accordingly not necessary in such designs. In the present invention, the inflator socket and socket insert can also be used with non-serviceable squib assemblies, in which case the shorting clip may be left out of the assembly.

The squib connector socket assembly of the present invention is readily manufactured at high volume and low cost relative to prior art machined sockets with shorting clips. The injection molding process for the plastic insert eliminates the presence of metal burrs and slivers and is dimensionally more reliable than machining processes. The shorting clip design can readily accommodate igniter pins which are not parallel. Also, although described in relation to a two-pin squib assembly, the invention is applicable to squib assemblies with other numbers of pins. Crimping the extruded inflator socket about the insert and squib assembly results in an inseparable, integral final assembly. The squib connector socket assembly is sufficiently versatile that it can be used for both serviceable and non-serviceable squib assemblies; in the latter case, the shorting clip may be left out of the final assembly.

The invention is not to be limited by what has been particularly shown and described, except as indicated by the appended claims.

- 8 -

CLAIMS

I claim:

- 5 1. A squib connector socket assembly for an automotive air bag, comprising:
- an inflator socket having an open interior region and opposed open ends;
- 10 a socket insert having side walls having an exterior configuration conformable to and disposed within the interior region of the inflator socket, the side walls defining an interior region, the socket insert further having a bottom wall having two apertures therein and an open end opposite the bottom wall;
- 15 a squib assembly having two igniter pins disposed to extend through the two apertures in the bottom wall of the socket insert; and
- 20 a resilient, electrically conductive, shorting clip fixedly retained within the interior region of the inflator socket, the shorting clip biased into electrical contact with the igniter pins of the squib assembly;
- the inflator socket being crimped about the exterior of the socket insert and the squib assembly to form an integral assembly.
- 25 2. The squib connector socket assembly of claim 1, wherein the socket insert is formed of a plastic material.
- 30 3. The squib connector socket assembly of claim 2, wherein the plastic material is a nylon, polybutylene terephthalate, acetal, polyphenylene sulfide, or liquid crystal polymer.
4. The squib connector socket assembly of claim 1, wherein the socket insert is injection molded.
- 35 5. The squib connector socket assembly of claim 1, wherein the inflator socket is formed of a metal material.

- 9 -

6. The squib connector socket assembly of claim 5, wherein the metal material is aluminum or stainless steel.

5 7. The squib connector socket assembly of claim 1, wherein the inflator socket is formed by cold headed extrusion.

10 8. The squib connector socket assembly of claim 1, wherein the inflator socket includes an inwardly extending annular lip at one of the opposed open ends, the inflator socket disposed adjacent the annular lip.

15 9. The squib connector socket assembly of claim 1, wherein the shorting clip includes two independently movable beams, each beam being associated with one of the two igniter pins of the squib assembly.

20 10. The squib connector socket assembly of claim 1, wherein the shorting clip includes an upstanding member and two beams, a bend formed in the shorting clip adjacent a base of the beams, the upstanding member having an upper portion fixedly attached to an interior wall of the socket insert and diverging from the interior wall, the beams being disposed along the bottom wall of the socket insert to extend into electrical contact with associated ones of the igniter pins.

25 11. The squib connector socket assembly of claim 1, wherein the shorting clip includes two beams, each beam being associated with and extending into electrical contact with one of the two igniter pins of the squib assembly, each beam being bowed and in contact with the bottom wall of the socket insert at two points, and each of the two igniter pins exerts a force on the associated beam tending to further bow the beam.

35 12. The squib connector socket assembly of claim 11, wherein each beam includes a lip formed on an end thereof for

- 10 -

contacting the associated igniter pin, the lip having a turned-away end to allow insertion of a squib connector between the lip and the pin.

5 13. The squib connector socket assembly of claim 1, wherein the shorting clip is formed of a beryllium and copper alloy.

10 14. A shorting clip assembly for use in a squib connector socket assembly for an automotive air bag, the socket assembly comprising a two-pin squib assembly and an inflator socket for receiving a squib connector, the shorting clip assembly comprising:

15 a plastic socket insert having a side wall having an outer surface configured to fit within the inflator socket and an inner surface, a bottom wall disposed at one end of the side wall, an open end opposite the bottom wall, two openings formed in the bottom wall, the openings sized and located to receive two igniter pins of the two-pin squib assembly; and

20 a shorting clip fixedly retained within the socket insert and including an upstanding member and two beams, a bend formed in the shorting clip between the upstanding member and the beams, the upstanding member having an upper portion fixedly attached to the inner wall surface of the socket insert and diverging from the inner wall surface, the  
25 beams being disposed along the bottom wall of the socket insert to extend into electrical contact with associated ones of the two igniter pins.

30 15. The shorting clip assembly of claim 14, wherein each beam is bowed and in contact with the bottom wall of the socket insert at two points, and the length of the beams is preselected so that each of the two igniter pins exerts a force on the associated beam tending to further bow the beam.

35

- 11 -

16. The shorting clip assembly of claim 14, wherein the length of the two beams is preselected so that each of the two igniter pins exerts a force on the associated beam tending to move the upstanding member closer to the inner surface of the socket insert.

5

17. The shorting clip assembly of claim 14, wherein each beam includes a lip formed on an end thereof for contacting the associated igniter pin, the lip having a turned-away end to allow insertion of a squib connector between the lip and the pin.

10

18. The shorting clip assembly of claim 14, wherein the shorting clip is formed of a beryllium and copper alloy.

15

19. A squib connector socket assembly for an automotive air bag, comprising:

an inflator socket having an open interior region and opposed open ends;

a socket insert having side walls having an exterior configuration conformable to and disposed within the interior region of the inflator socket, the side walls defining an interior region, the socket insert further having a bottom wall having two apertures therein and an open end opposite the bottom wall; and

20

25

a squib assembly having two igniter pins disposed to extend through the two apertures in the bottom wall of the socket insert;

the inflator socket being crimped about the exterior of the socket insert and the squib assembly to form an integral assembly.

30

20. The squib connector socket assembly of claim 19, wherein the socket insert is formed of a plastic material.

35

- 12 -

21. The squib connector socket assembly of claim 20, wherein the plastic material is a nylon, polybutylene terephthalate, acetal, polyphenylene sulfide, or liquid crystal polymer.

5 22. The squib connector socket assembly of claim 19, wherein the socket insert is injection molded.

23. The squib connector socket assembly of claim 19, wherein the inflator socket is formed of a metal material.

10 24. The squib connector socket assembly of claim 23, wherein the metal material is aluminum or stainless steel.

15 25. The squib connector socket assembly of claim 19, wherein the inflator socket is formed by cold headed extrusion.

20 26. The squib connector socket assembly of claim 19, wherein the inflator socket includes an inwardly extending annular lip at one of the opposed open ends, the inflator socket disposed adjacent the annular lip.

27. A method of forming a squib connector socket assembly for an automotive air bag, comprising:

25 fixing a resilient, electrically conductive shorting clip into a plastic socket insert, the socket insert having a bottom wall having two openings therein, the shorting clip configured for biasing contact with two igniter pins of a squib assembly;

30 inserting the two igniter pins of the squib assembly into the two openings of the socket insert with the shorting clip biased into electrical contact with the igniter pins;

inserting the plastic socket insert and the squib assembly into an inflator socket having an exterior tubular configuration and opposed open ends; and

35 crimping the inflator socket about the socket insert and the squib assembly to form an integral assembly.

- 13 -

28. The method of claim 27, wherein the socket insert is formed by injection molding.

5

29. The method of claim 27, wherein the socket insert is formed of a nylon, polybutylene terephthalate, acetal, polyphenylene sulfide, or liquid crystal polymer.

10

30. The method of claim 27, wherein the shorting clip is fixed to the socket insert by stitching.

31. The method of claim 27, wherein the shorting clip is molded into the socket insert.

15

32. The method of claim 27, wherein the shorting clip is formed of a beryllium and copper alloy.

33. The method of claim 27, wherein the inflator socket is formed by cold headed extrusion.

20

34. The method of claim 27, wherein the inflator socket is formed of aluminum or stainless steel.

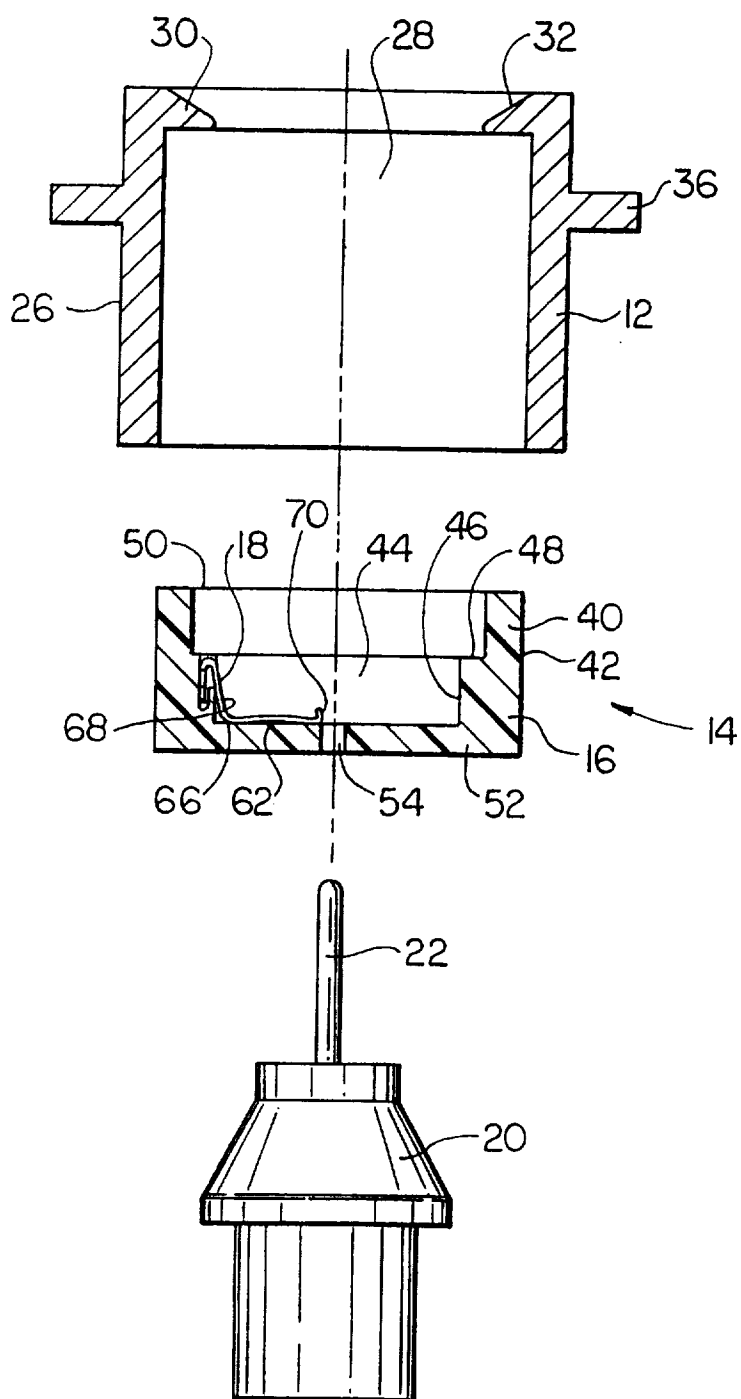

FIG. 1

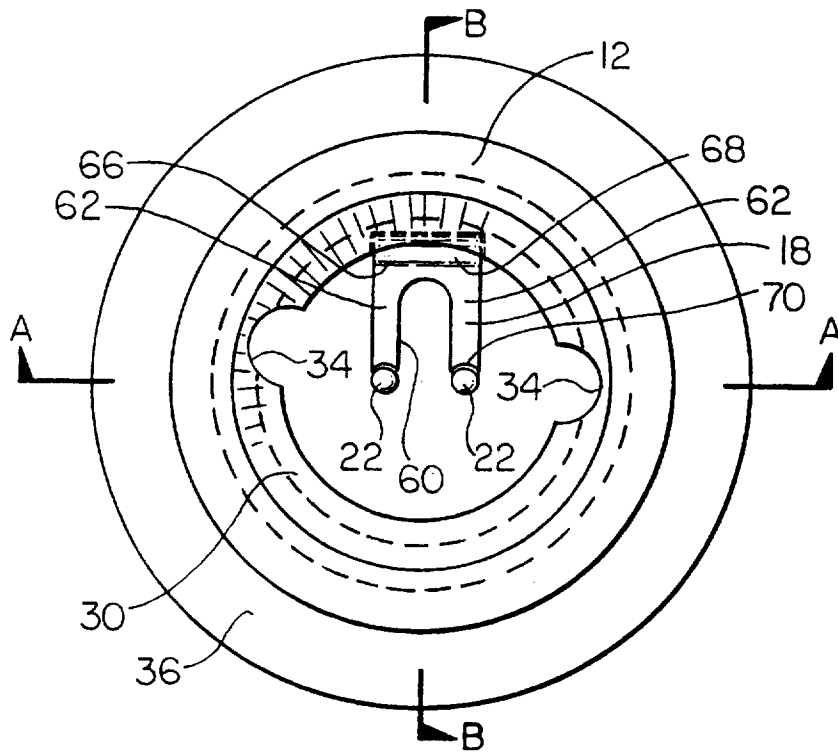

FIG. 2

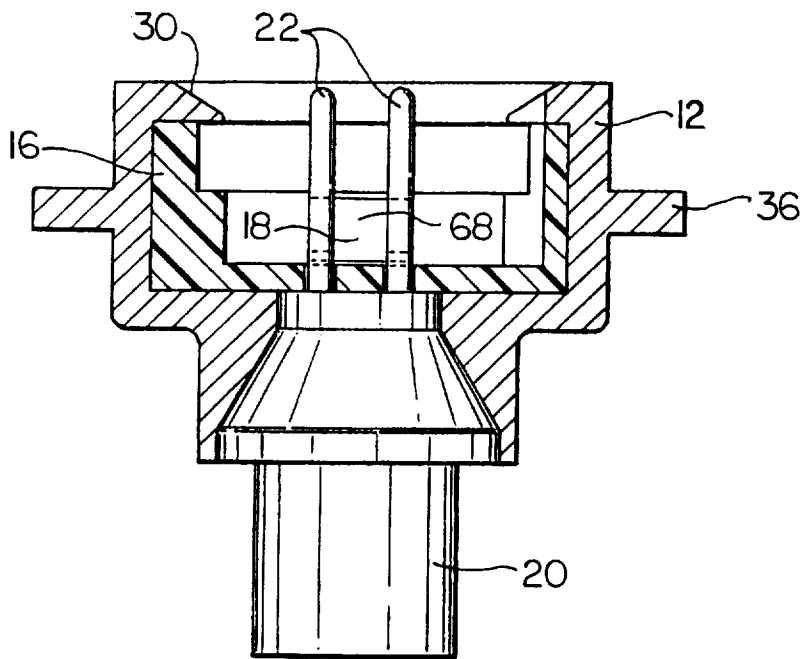

FIG. 3

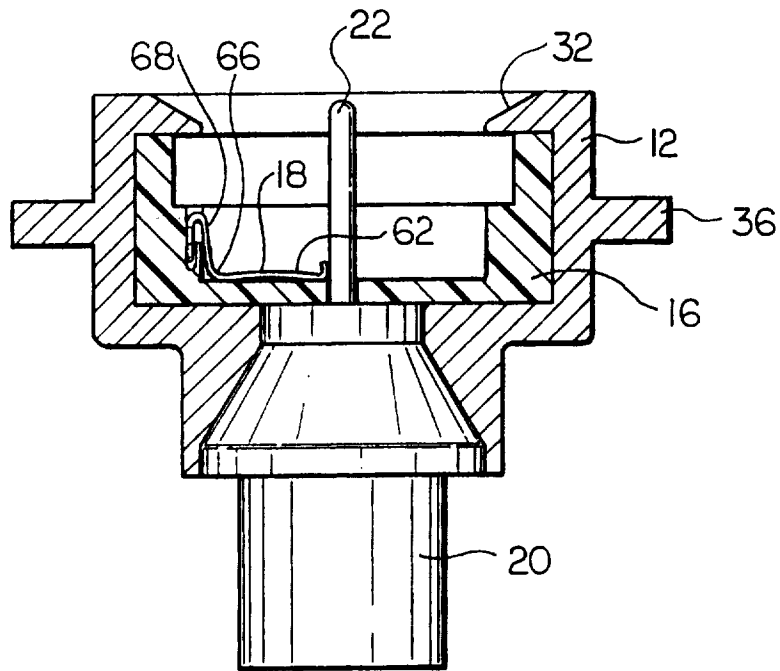

FIG. 4

INTERNATIONAL SEARCH REPORT

International application No.  
PCT/US97/14728

**A. CLASSIFICATION OF SUBJECT MATTER**

IPC(6) : HO1R 31/08  
US CL : 439/510, 507, 701, 904; 29/842

According to International Patent Classification (IPC) or to both national classification and IPC

**B. FIELDS SEARCHED**

Minimum documentation searched (classification system followed by classification symbols)

U.S. : 439/510, 507, 701, 904; 29/842

Documentation searched other than minimum documentation to the extent that such documents are included in the fields searched

Electronic data base consulted during the international search (name of data base and, where practicable, search terms used)

**C. DOCUMENTS CONSIDERED TO BE RELEVANT**

Category*	Citation of document, with indication, where appropriate, of the relevant passages	Relevant to claim No.
X	US, A, 5,106,324 (NATSUME) 21 APRIL 1992, see the entire document.	1-13, 19-26
X	US, A, 4,906,203 (MARGRAVE ET AL.) 6 MARCH 1990, see the entire document.	14-18
X	US, A, 3,460,234 (IANTORNO) 12 AUGUST 1969, see the entire document.	27-34

Further documents are listed in the continuation of Box C.  See patent family annex.

* Special categories of cited documents:	*T* later document published after the international filing date or priority date and not in conflict with the application but cited to understand the principle or theory underlying the invention
*A* document defining the general state of the art which is not considered to be of particular relevance	*X* document of particular relevance; the claimed invention cannot be considered novel or cannot be considered to involve an inventive step when the document is taken alone
*B* earlier document published on or after the international filing date	*Y* document of particular relevance; the claimed invention cannot be considered to involve an inventive step when the document is combined with one or more other such documents, such combination being obvious to a person skilled in the art
*L* document which may throw doubts on priority claim(s) or which is cited to establish the publication date of another citation or other special reason (as specified)	*A* document member of the same patent family
*O* document referring to an oral disclosure, use, exhibition or other means	
*P* document published prior to the international filing date but later than the priority date claimed	

Date of the actual completion of the international search

19 NOVEMBER 1997

Date of mailing of the international search report

15 DEC 1997

Name and mailing address of the ISA/US  
Commissioner of Patents and Trademarks  
Box PCT  
Washington, D.C. 20231

Facsimile No. (703) 305-3230

Authorized officer

G. ANTON SMITH

Telephone No. (703) 305-3747

*Sheila Vercy*  
Paralegal Specialist  
Group 3200

INTERNATIONAL SEARCH REPORT

International application No.  
PCT/US97/14728

Box I Observations where certain claims were found unsearchable (Continuation of Item 1 of first sheet)

This international report has not been established in respect of certain claims under Article 17(2)(a) for the following reasons:

- 1.  Claims Nos.:  
because they relate to subject matter not required to be searched by this Authority, namely:
  
- 2.  Claims Nos.:  
because they relate to parts of the international application that do not comply with the prescribed requirements to such an extent that no meaningful international search can be carried out, specifically:
  
- 3.  Claims Nos.:  
because they are dependent claims and are not drafted in accordance with the second and third sentences of Rule 6.4(a).

Box II Observations where unity of invention is lacking (Continuation of Item 2 of first sheet)

This International Searching Authority found multiple inventions in this international application, as follows:

Please See Extra Sheet.

- 1.  As all required additional search fees were timely paid by the applicant, this international search report covers all searchable claims.
- 2.  As all searchable claims could be searched without effort justifying an additional fee, this Authority did not invite payment of any additional fee.
- 3.  As only some of the required additional search fees were timely paid by the applicant, this international search report covers only those claims for which fees were paid, specifically claims Nos.:
  
- 4.  No required additional search fees were timely paid by the applicant. Consequently, this international search report is restricted to the invention first mentioned in the claims; it is covered by claims Nos.:

- Remark on Protest
- The additional search fees were accompanied by the applicant's protest.
  - No protest accompanied the payment of additional search fees.

**BOX II. OBSERVATIONS WHERE UNITY OF INVENTION WAS LACKING**

This ISA found multiple inventions as follows:

This application contains the following inventions or groups of inventions which are not so linked as to form a single inventive concept under PCT Rule 13.1. In order for all inventions to be searched, the appropriate additional search fees must be paid.

Group I, claim(s) 1-26, drawn to the apparatus squib connector and clip.

Group II, claim(s) 27-34, drawn to method of assembly of connector.

The inventions listed as Groups I and II do not relate to a single inventive concept under PCT Rule 13.1 because, under PCT Rule 13.2, they lack the same or corresponding special technical features for the following reasons: the search in group I is classified in a different classification than that of group II.