

April 2, 1940.

W. KOENIG

2,195,461

FOLDING CHAIR

Filed Feb. 8, 1938

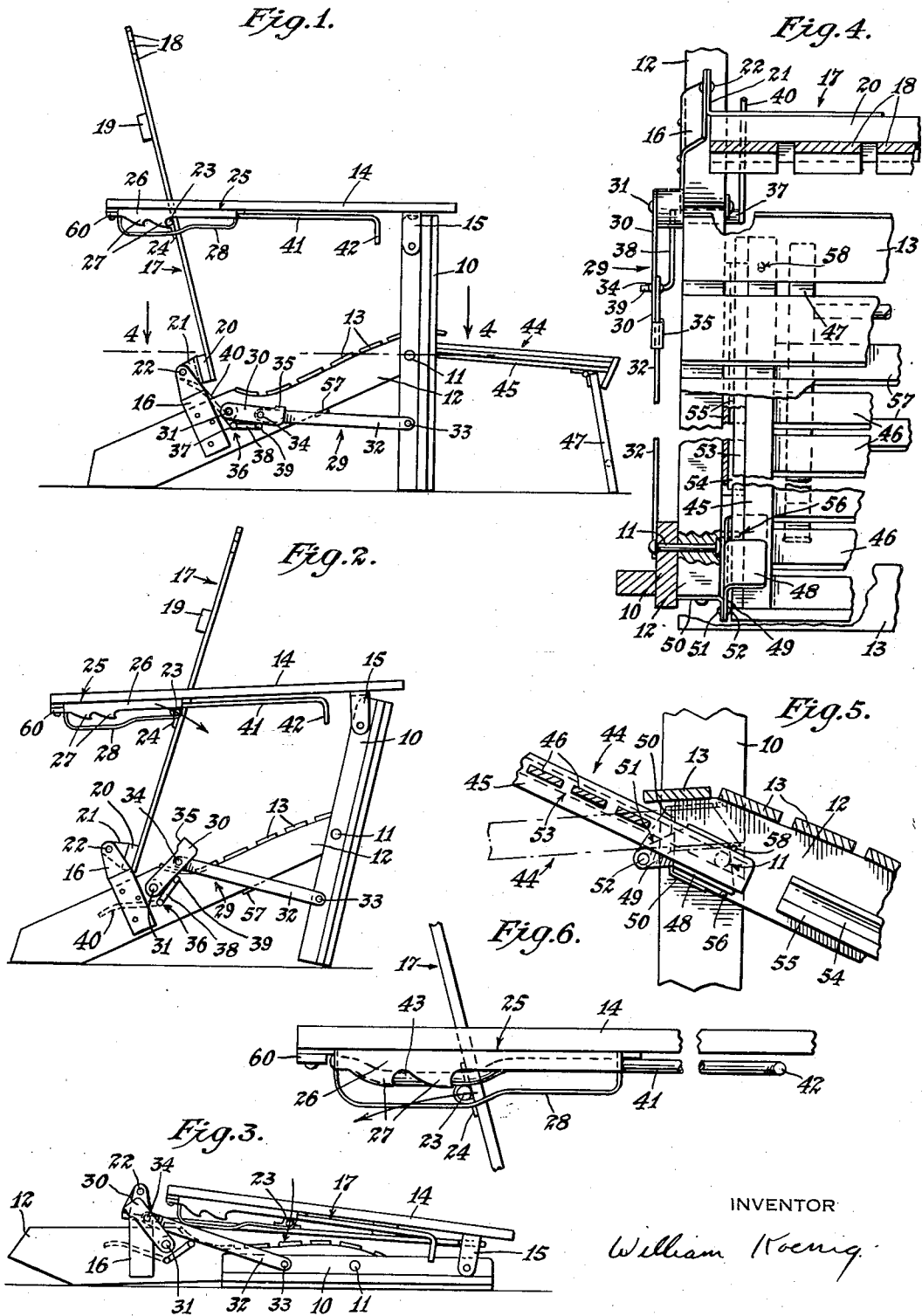

INVENTOR

William Koenig

UNITED STATES PATENT OFFICE

2,195,461

FOLDING CHAIR

William Koenig, Tottenville, N. Y.

Application February 8, 1938, Serial No. 189,291

3 Claims. (Cl. 155—139)

This invention relates to folding chairs and particularly to the type known as an Adirondack chair, and has for its principal object to provide a structure that may be instantly and readily folded into a most compact form, a further object resides in the folding or unfolding of the chair by the manual movement of the back alone. Another object of the invention is to provide improved means for supporting an extensible leg rest, and a further object is the provision of convenient means for adjusting the angle of inclination of the back of the chair while the same is being occupied.

The invention consists of the provision of certain pivotal connections between the back of the chair and inclined rear legs, and between the arms and front legs, the latter being also pivoted to the rear legs. The back is pivoted in such a manner as to form a lever effective when the back is swung forwardly to actuate rock levers supported on the rear legs, which, when the back is initially moved to fold the chair, will operate to break the buggy joints of side braces on either side of the chair, and which latter are pivotally connected at their opposite ends to the front and rear legs. A connection between the back and the arms is slidably effective to completely fold the chair following the breaking of the joints of the side braces.

When the chair is unfolded the aforesaid slidable connection between the back and the arms is effective in an opposite direction to permit straightening the side braces which then hold the structure rigidly in place without danger of any accidental collapse of the chair.

These objects are accomplished by the construction illustrated in the accompanying drawing in which:

Fig. 1 is a side elevation of a folding chair embodying this invention.

Fig. 2 is a side elevation of the chair partly folded.

Fig. 3 is a side elevation of the chair completely folded.

Fig. 4 is an enlarged fragmentary horizontal section on the line 4—4 of Fig. 1, but with the leg rest retracted.

Fig. 5 is a side view of the forward portion of Fig. 4 looking toward the left, but showing the leg rest partially withdrawn in full lines, and its fully withdrawn position corresponding to Fig. 1, in broken lines, and,

Fig. 6 is an enlarged detail side elevation of the arm of the chair with means for controlling the adjustment of the back shown in a position

effective for permitting changing the angle of the back.

The chair comprises front legs 10 pivoted at 11 to inclined rear legs 12. Slats 13 extend across the chair to form a seat and are secured to the upper surface of the rear legs. Legs 10 are pivoted to brackets 15 which are rigidly secured to the arms beneath same. Secured to the sides of the rear legs 12 adjacent their lower ends and extending upwardly therefrom, are brackets 16.

The back 17 of the chair consists of vertical slats 18 with upper and lower cross cleats 19 and 20. Cleat 20 at the extreme lower end of the back 17 is provided with end brackets 21 which are pivotally secured to the brackets 16 as at 22. Extending, in this instance, entirely across the back 17 and in the rear thereof is a rod 23 secured to the back by straps 24. The ends of rod 23 extend beyond the side edges of the back and enter box-like fittings 25 secured to the under side of arms 14. Fittings 25 consist of sides 26 notched on their lower edge to provide teeth 27 for engagement with the ends of rod 23 so that the back may be supported in several angular positions with respect to the seat of the chair. The bottom of fittings 25 consists of a flat strap 28 spaced from the bottom edge of sides 26 and bent as shown, the purpose of all of which will presently appear.

The front and rear legs are rigidly connected to each other by braces 29, one on each side of the chair, consisting respectively of a short link 30 pivotally connected to a rear leg at 31, and a long link 32 pivotally connected to a front leg at 33. Links 30 and 32 are pivoted to each other at 34. Link 30 is provided with an ear 35 formed from its top edge so as to extend over the top of link 32 and downwardly to form a U-shaped pocket. This ear is effective as shown in Fig. 1 to prevent the links from dropping beyond a predetermined position in which the pivot 34 will be slightly below a plane passing through pivots 31 and 33. It will thus be seen that any movement of the front legs in a clockwise direction about pivot 11 will be prevented because the resulting thrust on pivot 34 is downwardly and will be arrested by ear 35. Conversely any movement in an opposite direction will only result in a substantially straight line pull on the braces and there will be no appreciable movement of the legs about pivot 11, the chair being thus held rigidly braced as shown in Fig. 1.

In order to effect relative movement of the rear and front legs about pivot 11 to fold the chair

it obviously becomes necessary to raise pivot 34 so that the braces 29 will assume a position in which the links 30 and 32 will be out of alignment. This is accomplished by actuating a pair of crank levers 36 one of which is mounted on each rear leg. They may be of any suitable construction such as a rod or tube 37 extending transversely in a horizontal plane through a rear leg 12. On the outer end of rod 37 is secured a relatively short arm 38 extending forwardly below brace 29 and bent at its outer end as at 39 so as to extend beneath link 30 adjacent pivot 34. On the inner end of rod 37 is secured a relatively long arm 40 extending rearwardly and upwardly beneath the lower rear edge of cleat 20 of the chair back 17.

It will thus be seen that when the back is swung forwardly or clockwise about pivot 22, the lower rear edge of cleat 20 will move in a downward direction and engage arm 40. A further movement of the back 17 will then cause arm 40 to move and rock rod 37 in a counterclockwise direction. This movement will lift arm 38 and the end 39 will then lift link 30 with the result that the latter and link 32 will be thrown out of alignment upwardly thereby slightly swinging the front legs about pivot 11.

During this initial movement of back 17 rod 23 will have slid along the lower edge of the sides 26 of fitting 25 and into contact with the end of strap 28, as shown in Fig. 2. The continued movement of back 17 will now carry the arms 14 of the chair toward the right by virtue of the pressure of rod 23 against the end of strap 28, and they in turn will swing the front legs further about pivot 11. At the same time the jointed links of braces 29 will yield freely until complete folding of the chair has been effected as shown in Fig. 3.

It will be noted that the back 17 when in this position does not extend beyond the ends of the legs or arms, the whole structure lying compactly in substantially parallel planes so as to occupy a minimum amount of storage space and to permit the chair to be easily transported.

Journalled in fittings 25 and extending through and beyond the same beneath arms 14 and longitudinally thereof, are rock levers 41, bent downwardly at their forward ends to provide handles 42. That portion of the rock levers that is within the fitting 25 adjacent the teeth 27 is bent to form an offset 43 extending in a plane substantially at a right angle to that of handles 42.

When it is desired to change the angle of the back 17 from the position shown in Fig. 1 the occupant of the chair may swing the handles 42 upwardly and outwardly to the position shown in Fig. 6. This will rotate the offset portion 43 into a position where its lower surface will then be in a plane corresponding to that of the lower ends of teeth 27. During this movement of rock levers 41 the offset 43 will engage the ends of rod 23 which will result in the arms 14 of the chair being slightly elevated. The back 17 may now be pushed rearwardly because rod 23 sliding along the contiguous surface of offset 43 cannot then engage teeth 27 and may be moved to the extreme rear of fitting 25 and into engagement with the rear end of strap 28 corresponding to the greatest degree of inclination of the back 17. Should an intermediate position of the back be desired rock levers 41 are first restored to normal position, rod 23 is then free to engage any particular tooth as the back 17 is again swung forwardly.

As shown in Figures 1, 4 and 5, an extensible leg rest 44 may be provided consisting of side rails 45 connected by cross slats 46, one of the forward ones having hinged thereto, legs 47 so as to fold beneath the leg rest.

Leg rest 44 is slidably supported in U-shaped brackets 48 having ears 49. Secured to the forward ends of rear legs 12 are brackets 50 having ears 51 pivoted at 52 to ears 49 of brackets 48 so that the latter may swing on said pivots. Rails 45 are provided with tongues 53 adapted to slide in grooves 54 in cleats 55 secured to the inner sides of the rear legs 12 and substantially parallel with the lower edge thereof.

When not in use leg rest 44 is supported beneath the seat slats 13. To reach this position the tongues 53 slide along grooves 54 after the forward end of the rest has been elevated sufficiently, as shown in Fig. 5, by swinging it about pivot 52 until the tongues and grooves are aligned.

Such aligned position is definitely determined by the aid of stop pins 56 projecting inwardly from the inner sides of legs 12 and which are adapted to be engaged by the lower surface of brackets 48 when such aligned position has been reached. It is then only necessary to push the rest 44 rearwardly and tongues 53 will enter grooves 54 the rails 45 sliding through the brackets 48. Prior to this operation the legs 47 are folded up against the bottom of the rest 44 and are subsequently maintained in this position, by a cross member 57 secured beneath legs 12.

When leg rest 44 is pulled out into the position shown in full lines in Fig. 5 pins 58 projecting upwardly from rails 45 engage the rear edge of brackets 48 and prevent the rest from being accidentally pulled entirely through brackets 48. When in this position the rest may be swung about pivot 52 to the position shown in broken lines, whereupon the extreme rear end will move up close to the seat slats 13 and the upper surface of the rest will be then brought up desirably near the level of the chair seat which adds materially to the comfort derived from the use of the leg rest.

The rear ends of the arms of the chair may be connected by a suitable cross member 60.

What I claim is:

1. In a folding chair having vertical front legs, inclined rear legs pivotally secured to said front legs, a seat secured to the forward upper portions of the rear legs, a back pivotally secured to the rear legs, and slidably connected to arms pivotally secured to the front legs adjacent the top thereof, a jointed brace pivotally secured at one end to a front leg and at the other end to a rear leg of the chair, and normally effective to prevent any relative movement of the said legs about their pivotal connection, and means adapted to be actuated by a forward movement of said back for breaking the joint of said brace to permit folding of the chair.

2. In a folding chair having vertical front legs, inclined rear legs pivotally secured to said front legs, a seat secured to the forward upper portions of the rear legs, a back pivotally secured to the rear legs, and slidably connected to arms pivotally secured to the front legs adjacent the top thereof, a jointed brace pivotally secured at one end to a front leg and at the other end to a rear leg of the chair, and normally effective to prevent any relative movement of the said legs about their pivotal connection, means adapted to be actuated by a for-

ward movement of said back for breaking the joint of said brace to permit folding of the chair, and slidable connections between the back and the arms of the chair whereby the back
5 may be free to move initially a predetermined distance relative to said arms to effect the actuation of the said means, and then move said arms to fold the chair.

3. In a folding chair having vertical front legs,
10 inclined rear legs pivotally secured to said front legs, a seat secured to the forward upper portions of the rear legs, a back pivotally secured to the rear legs, and slidably connected to arms pivotally secured to the front legs adjacent the

top thereof, a brace consisting of links pivotally connected at one end and having their other ends pivotally secured respectively to a front and rear leg of said chair, said links being normally in substantially aligned position,
5 and a lever mounted to rock on said rear leg, one end of said lever being adapted to be engaged and moved by the lower end of said back when the latter is initially swung forwardly
10 on its pivot, and the other end of said lever having means adapted to engage said brace and move the links thereof out of said aligned position.

WILLIAM KOENIG.