

J. MANQUAT.
 WINDING MACHINE FOR ARTIFICIAL THREADS.
 APPLICATION FILED MAY 28, 1912.

1,067,534.

Patented July 15, 1913.

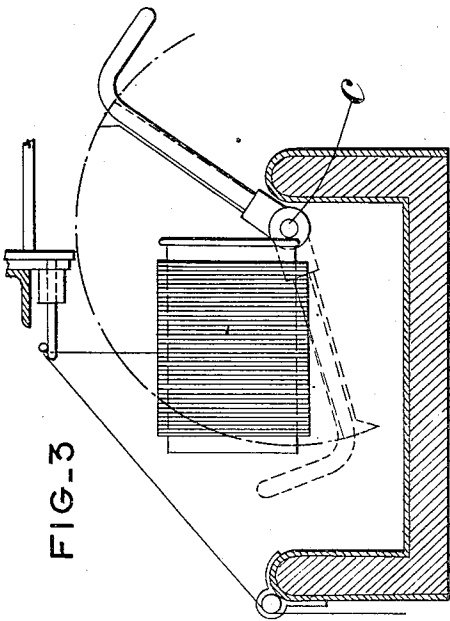

FIG. 3

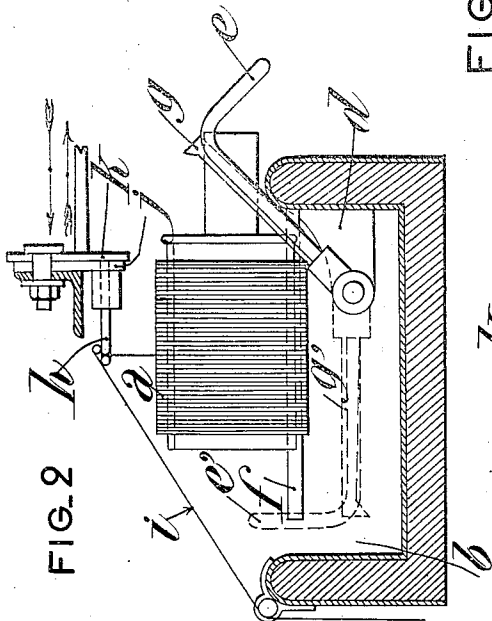

FIG. 2

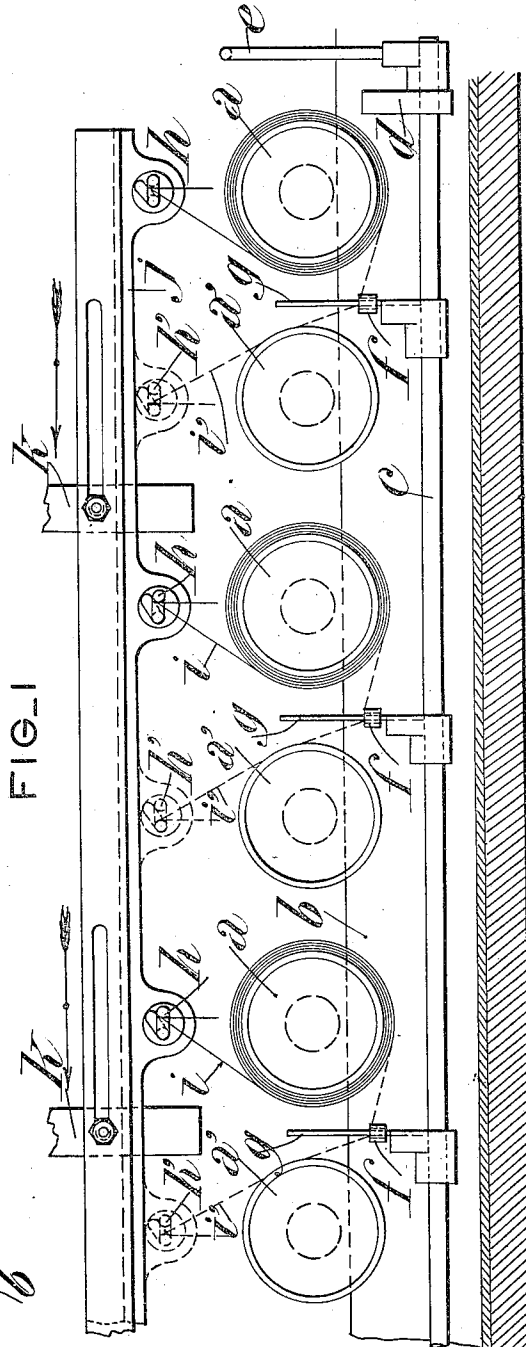

FIG. 1

WITNESSES:

John C. Sanders
Albert F. Heuman

INVENTOR:

BY *Jean Manquat*
M. Wallace White

ATTY

UNITED STATES PATENT OFFICE.

JEAN MANQUAT, OF VILLEURBANNE, FRANCE.

WINDING-MACHINE FOR ARTIFICIAL THREADS.

1,067,534.

Specification of Letters Patent.

Patented July 15, 1913.

Application filed May 28, 1912. Serial No. 700,157.

To all whom it may concern:

Be it known that I, JEAN MANQUAT, a citizen of the French Republic, residing at Villeurbanne, Rhône, in France, have invented certain new and useful Improvements in Winding-Machines for Artificial Threads, of which the following is a specification.

This invention relates to improvements in winding machines for artificial threads.

10 In order to increase the production in the spinning of artificial threads it has been customary to employ two bobbins and when one is sufficiently wound the other is rapidly brought into action in such a manner that
15 the continuity of the spinning is not disturbed, the inconveniences which might otherwise result being prevented. This operation has hitherto been manually effected but however skilled the workman may be a
20 certain difference between the quality and quantity of the thread on the first and on the final bobbin is always found, showing that they are not all stopped at the same
25 time and that the peripheral speed of a full bobbin is greater than that for an empty bobbin for a constant angular speed. Further the aforesaid manually effected changes
30 occupy a considerable time, a large number of bobbins being usually under the supervision of one operative.

The object of the present invention is to obviate the said inconveniences and for this purpose the invention consists in a device which allows of simultaneously releasing all
35 the filled bobbins on one side of the machine and immediately engaging all the empty bobbins.

The annexed drawings illustrate by way of example forms of construction of this
40 device.

Figure 1 being a front view, Fig. 2 a cross section, and Fig. 3 a cross section of a modified form of construction.

45 In Figs. 1 and 2, a represents the bobbins on which the thread is wound. a^1 indicates the empty bobbins, b the tank containing the coagulating and fixing substance in which the bobbins are partly immersed; this tank is traversed longitudinally by a rod c
50 carried by bearings d and adapted to be axially rotated by means of a handle or lever e .

Between each pair of bobbins a and a^1 are plates f of U-shaped section and which
55 are rigidly secured to the tank b and knives

g mounted on the rod c and turning with it when the handle e is operated, engage between the limbs of the different plates f .

The glass rings or guides h which the different threads i i^1 traverse, are carried
60 on a beam j adapted to be given longitudinal movement (by means not shown) for about the distance which separates the axes of the different bobbins and also a transverse reciprocating movement by means of supports k
65 in order to produce the usual winding.

The operation of the device is as follows:—The glass rings h being in the position shown in full lines in Fig. 1, the bobbins a are winding while the bobbins a^1 are
70 stationary. When said bobbins a are completely wound, the bobbins a^1 are brought into action, whereupon the knives g being raised to the position shown in full lines, the beam j is displaced from right to left
75 in the direction of the arrows Fig. 1, so as to conduct the guides h to the position h^1 shown in broken lines in Fig. 1. If at this moment the knives g are lowered by moving the lever e into position e^1 (Fig. 2), the
80 said knives are introduced between the limbs of the plates f as shown in position g^1 (Fig. 2) and will cut or break the threads i which are thus brought into contact with the bobbins a^1 to which they adhere and are wound
85 by said bobbins in the same manner as they were previously wound on the bobbins a . When said bobbins a^1 are filled, the reverse procedure to that described takes place by shifting the beam j from left to right.
90

The number of bobbins and consequently that of the knives g , plates f , glass rings h , etc., can be in accordance with the size of the machine to which the present device is
95 applied.

In the construction shown in Fig. 3, the rod c is arranged at a higher level than in Figs. 1 and 2, and the plates f of Figs. 1 and 2 are dispensed with, these plates not being
100 absolutely necessary to the success of the operation described.

What I claim as my invention and desire to secure by Letters Patent of the United States is:—

1. In a winding machine for artificial
105 threads, the combination with a pair of bobbins mounted for axial rotation, of a reciprocating thread guide movable in the direction of its length and parallel to a line connecting the axes of said bobbins and a
110

knife located between the bobbins and adapted to sever the thread between the guide and bobbins.

2. In a winding machine for artificial threads, the combination with a pair of bobbins mounted for axial rotation and a thread guide mounted adjacent said bobbins, of a reciprocating support for said guide movable in the direction of its length and parallel to a line connecting the axes of said bobbins, and transversely thereto, and a knife located between the bobbins and adapted to sever the thread between the guide and either of the bobbins.

3. In a winding machine for artificial threads, the combination with a plurality of pairs of bobbins mounted for axial rotation, of a thread guide for each pair of bobbins movable parallel to a line connecting the axes of said bobbins, a knife for each pair of bobbins adapted to sever the thread between the guide and either bobbin of a

pair and means for actuating all said knives simultaneously.

4. In a winding machine for artificial threads, the combination with a plurality of pairs of bobbins mounted for axial rotation and a thread guide for each pair of bobbins, of a support carrying all said guides and movable parallel to a line connecting the axes of said bobbins and transversely thereto, a knife located between each pair of bobbins adapted to sever the thread between the guide and either bobbin of a pair and means for manually actuating all said knives simultaneously.

In witness whereof I have signed this specification in the presence of two witnesses.

JEAN MANQUAT

Witnesses:

GASTON JEANNIAUD,
CLARENCE CASSI, JUNR.