

Nov. 17, 1964

A. S. HAKIM

3,157,302

CONTAINER

Filed March 3, 1964

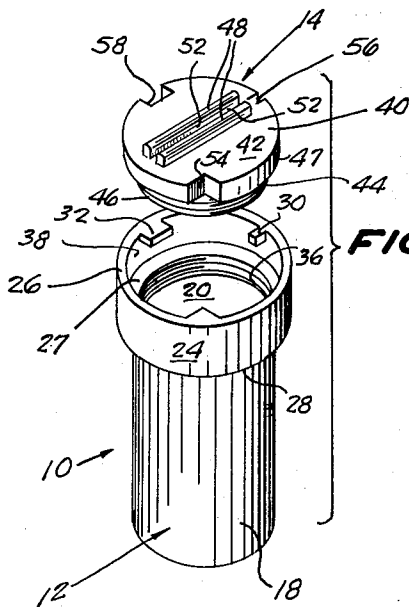

FIG. 1.

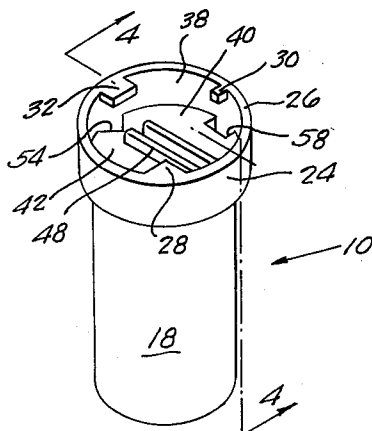

FIG. 2.

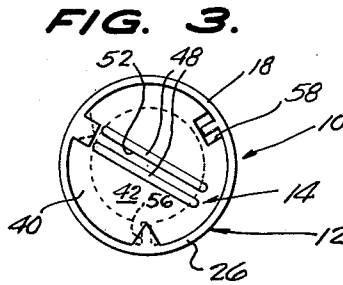

FIG. 3.

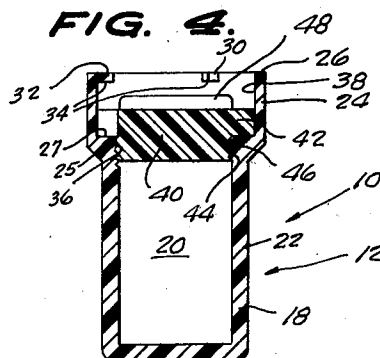

FIG. 4.

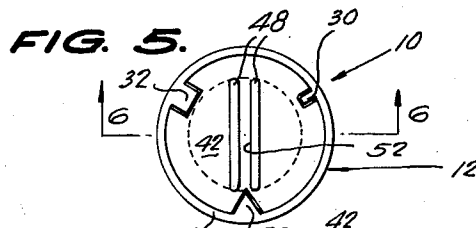

FIG. 5.

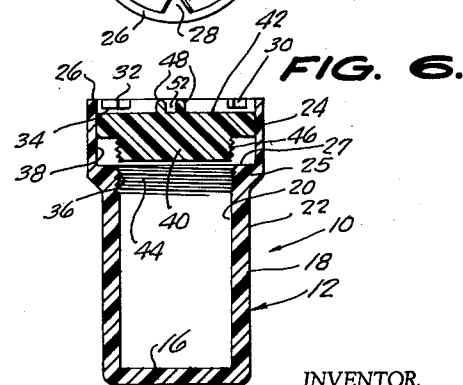

FIG. 6.

INVENTOR.

ALBERT S. HAKIM,

BY

*McMorrow, Berman & Davidson*  
ATTORNEYS.

1

3,157,302  
CONTAINER

Albert S. Hakim, % York, 326 De Siard, Monroe, La.  
Filed Mar. 3, 1964, Ser. No. 349,008  
5 Claims. (Cl. 215-9)

This invention relates to containers generally, and more specifically, to a safety container for storage of potentially harmful substances such as certain medicines, poisons, and the like.

A primary object of this invention resides in the provision of a safety container involving a receptacle and a closure means therefor, there being dual locking means to positively prevent access to the contents of the receptacle by children or by other persons not competent to handle materials of the type indicated above. Numerous devices relating to the general concept of supplying a medicine container and a closure means not readily operated by children have been previously proposed. However, such previously proposed devices have failed to find general acceptance. It is therefore an object of the present invention to provide a device of the character indicated which is effective for the purpose of positively preventing access to the contents of a receptacle by unauthorized persons, and which is susceptible of manufacture at a cost competitive with conventional containers for such substances.

Another object of the invention relates to the provision of a dual lock means for a container closure, or the like.

The general objects and advantages of the invention include the provision of a container and closure means therefor which is relatively inexpensive to manufacture and sell and durable in use. Other and further objects and advantages of the present invention will become apparent to those skilled in the art from a consideration of the following specification when read in conjunction with the annexed drawing, in which:

FIGURE 1 is a disassembled perspective view of a container and closure means therefor constructed and assembled in accordance with the teachings of this invention;

FIGURE 2 is a view similar to FIGURE 1, showing the closure means in place;

FIGURE 3 is a top plan view thereof;

FIGURE 4 is a vertical cross sectional view, taken substantially along the section line 4-4 of FIGURE 2, looking in the direction of the arrows;

FIGURE 5 is a top view similar to FIGURE 3, showing the elements in position for disassembly; and

FIGURE 6 is a sectional view along the line 6-6 of FIGURE 5, looking in the direction of the arrows.

Referring to the drawing in more detail, the container of this invention is generally designated by reference character 10, and has, as its major components, a cup-like receptacle 12 and closure 14.

The receptacle 12, in the illustrated embodiment, includes a base 16 from which extends a tubular side wall 18 having an inner surface 20 and outer surface 22. The wall 18 includes an enlarged upper end portion 24 terminating in an end edge 26. As will be apparent from the description of function below, the configuration of the receptacle below the upper end portion 24 may be varied as desired. In the disclosed embodiment, the upper end portion 24 is connected to the wall 18 by a shoulder 25, and is of reduced thickness. This provides an interior ledge or shoulder 27, the purpose of which appears below.

At spaced locations about the interior periphery of the end edge 26, a plurality of lugs extend inwardly from the inner surface of the portion 24. The lugs are preferably of various, mutually distinct forms and configurations, such as the three illustrated lugs involving a gen-

2

erally triangular lug member 28, a narrow rectangular block lug 30, and a wide rectangular block lug 32. The lugs include lower sides 34 occupying, preferably, a common horizontal plane.

5 The inner surface of the wall 18 adjacent the shoulder 25 has screw thread means 36 formed therein. Thus, a smooth inner wall section 38 is provided on the portion 24.

10 The closure 14 comprises a body 40 having an enlarged upper end portion 42, adapted to rest on the ledge or shoulder 27, and a depending, reduced portion 44, the body portions being of generally discoidal configuration. The reduced portion 44 has a side edge 46 which is screw threaded for engagement with the thread means 36 of the receptacle 12. As best seen in FIGURE 6, the body 40 is of a diameter, and is of such depth from its upper portion 42 to its lower reduced portion 44, less than the distance between the lug lower sides 34 and the thread means 36, whereby it is freely movable and rotatable within the smooth wall portion 38. It is preferable however that the outside diameter of the upper portion 42 and the inside diameter of the wall 38 be held to close tolerance, and that the side edge 47 of the upper portion be squared, to prevent relative movement in other than 25 linear fashion.

30 The body 40 has an upwardly projecting, substantially centrally located pair of projections 48, defining a slot 52 therebetween, the slot 52 being adapted to receive a small coin, screwdriver, or other small, straight edged instrument for turning the closure, thus rendering it difficult for a child to grasp the same for manual turning of the closure. The coin or tool must be of such width as to frictionally engage the sides of the slot.

35 The slot is of such form that an adult, by reasonably careful manipulation, is able to engage a coin or the like therein and manually turn the closure when the threaded portion 46 is disengaged from the thread means 36. In emergency situations, when an opening tool is unavailable, the user may grasp the projections 48.

40 The upper portion 42 of the closure has a plurality of openings formed therein, opening on the side edge 47. Such openings correspond in number, location, and configuration with the plurality of lugs—as shown herein, comprising a triangular opening 54, a thin rectangular opening 56, and a wide rectangular opening 58—the openings corresponding respectively, to the triangular lug 28, the thin rectangular lug 30, and the wide rectangular lug 32.

45 In initial placement of the closure 14 on the receptacle 12, the corresponding lugs and openings are aligned and the body 40 is dropped into place—a suitable tool being used to cause engagement between the threads 46 and the thread means 36. When opening is desired, it is necessary to (1) select a tool capable of insertion in the slot 48 and frictionally engageable therein, (2) correctly turn the closure in the appropriate direction to disengage the threads and thread means, (3) withdraw the tool and closure manually and bring the respective corresponding lugs and slots into registry, and (4) manually lift the tool and closure upwardly. This sequence of steps is of such difficulty as to effectively prevent access to the contents of the receptacle of this invention by children, infirm persons, and the like.

50 Having described and illustrated an embodiment of this invention in detail, it will be understood that this description and illustration is offered merely by way of example, and that this invention is to be limited in scope only by the appended claims.

70 What is claimed is:

1. A safety container for medicine or the like, the container comprising—

3

- (I) A receptacle comprising:
- (a) a base portion;
  - (b) a tubular wall extending from the base portion and having an upper end portion terminating in an end edge;
  - (c) the tubular wall having an inner surface and an outer surface;
  - (d) at least three inwardly projecting lugs of mutually distinct configuration extending from the inner surface of the tubular wall at the end edge thereof, the lugs including lower sides;
  - (e) the inner surface having screw thread means formed therein terminating at a location spaced a selected distance from the lug lower sides, there being a smooth wall between the thread means and the lug lower sides; and
- (II) A receptacle closure comprising:
- (f) a generally disc-shaped body portion having an upper side, an under side, and a side edge;
  - (g) thread means on the side edge of the body portion engageable with the screw thread means of the receptacle wall inner surface;
  - (h) the closure being of a depth from its upper side to its under side of less than said selected distance;
  - (i) an upwardly projecting boss on the body portion upper side having a turning slot therein; and
  - (j) at least three openings in the body portion adapted for registry with the lugs on the container wall whereby the closure is removable from the receptacle.
2. A safety container for medicine and the like, the container comprising—
- (I) A receptacle comprising:
- (a) a base portion;
  - (b) a tubular wall extending from the base portion and having an upper end portion terminating in an end edge;
  - (c) a plurality of inwardly projecting lugs of mutually distinct configuration extending from the tubular wall at the end edge thereof, the lugs including lower sides;
  - (d) the tubular wall having screw thread means formed therein terminating at a location spaced a selected distance from the lug lower side; and
- (II) A receptacle closure comprising:
- (e) a body portion having an upper side, an under side, and a side edge;
  - (f) thread means on the side edge of the body portion engageable with the screw thread means of the receptacle wall;
  - (g) the closure being of a depth from its upper

4

- side to its under side of less than said selected distance;
- (h) an upwardly projecting boss on the body portion upper side having a turning slot therein; and
  - (i) a plurality of openings in the body portion adapted for registry with the lugs on the container wall whereby the closure is removable from the receptacle.
3. A safety container for medicine and the like, the container comprising:
- (I) A receptacle comprising:
- (a) a base;
  - (b) a tubular wall secured to the base and having an open end;
  - (c) a plurality of inwardly projecting lugs adjacent said open end the lugs being of given configurations;
  - (d) engagement means on said wall spaced inwardly from the lugs; and
- (II) A receptacle closure comprising:
- (e) a body portion;
  - (f) means on the body portion to engage the engagement means of the receptacle; and
  - (g) openings adapted for registry with said lugs, the openings being of configurations to correspond with the lug configurations whereby the closure is removable from the receptacle.
4. A safety container as defined in claim 3 wherein:
- (a) a smooth wall section extends between said engagement means and said lugs of said receptacle.
5. An article of manufacture comprising:
- (a) a tubular wall having at least one open end portion terminating in an end edge;
  - (b) the tubular wall having screw thread means formed therein at a location spaced inwardly from said end edge;
  - (c) a closure cap for said open end having thread means thereon adapted to engage the screw thread means of said wall;
  - (d) the wall having a plurality of inwardly projecting lugs thereon of mutually distinct configuration;
  - (e) the closure having openings formed therein adapted to register with said inwardly projecting lugs; and
  - (f) a smooth wall section extending between said screw thread means and said lugs.

## References Cited in the file of this patent

## UNITED STATES PATENTS

788,495	Sawin	Apr. 25, 1905
839,353	Wiedemann	Dec. 25, 1906