

(19) World Intellectual Property  
Organization  
International Bureau



(43) International Publication Date  
22 July 2004 (22.07.2004)

PCT

(10) International Publication Number  
**WO 2004/061218 A1**

- (51) International Patent Classification<sup>7</sup>: **D21F 11/00**
- (21) International Application Number:  
PCT/US2003/013484
- (22) International Filing Date: 30 April 2003 (30.04.2003)
- (25) Filing Language: English
- (26) Publication Language: English
- (30) Priority Data:  
10/325,565 19 December 2002 (19.12.2002) US
- (71) Applicant: **KIMBERLY-CLARK WORLDWIDE, INC.** [US/US]; 401 N. Lake Street, Neenah, WI 54956 (US).
- (72) Inventors: **BAKKEN, Andrew, Peter**; 3608 North Winterset Drive, Appleton, WI 54915 (US). **BURAZIN, Mark, Alan**; 11 Stoney Beach Road, Oshkosh, WI 54902 (US). **LINDSAY, Jeffrey, Dean**; 20 Diane Lane, Appleton, WI 54915 (US).
- (74) Agents: **CHARLIER, Patricia, A.** et al.; Kimberly-clark Worldwide, Inc., 401 N. Lake St., Neenah, WI 54956 (US).
- (81) Designated States (*national*): AE, AG, AL, AM, AT, AU, AZ, BA, BB, BG, BR, BY, BZ, CA, CH, CN, CO, CR, CU, CZ, DE, DK, DM, DZ, EC, EE, ES, FI, GB, GD, GE, GH, GM, HR, HU, ID, IL, IN, IS, JP, KE, KG, KP, KR, KZ, LC, LK, LR, LS, LT, LU, LV, MA, MD, MG, MK, MN, MW, MX, MZ, NI, NO, NZ, OM, PH, PL, PT, RO, RU, SC, SD, SE, SG, SK, SL, TJ, TM, TN, TR, TT, TZ, UA, UG, UZ, VC, VN, YU, ZA, ZM, ZW.
- (84) Designated States (*regional*): ARIPO patent (GH, GM, KE, LS, MW, MZ, SD, SL, SZ, TZ, UG, ZM, ZW), Eurasian patent (AM, AZ, BY, KG, KZ, MD, RU, TJ, TM), European patent (AT, BE, BG, CH, CY, CZ, DE, DK, EE, ES, FI, FR, GB, GR, HU, IE, IT, LU, MC, NL, PT, RO, SE, SI, SK, TR), OAPI patent (BF, BJ, CF, CG, CI, CM, GA, GN, GQ, GW, ML, MR, NE, SN, TD, TG).
- Published:**  
— with international search report
- For two-letter codes and other abbreviations, refer to the "Guidance Notes on Codes and Abbreviations" appearing at the beginning of each regular issue of the PCT Gazette.*

(54) Title: NON-WOVEN THROUGH AIR DRYER AND TRANSFER FABRICS FOR TISSUE MAKING

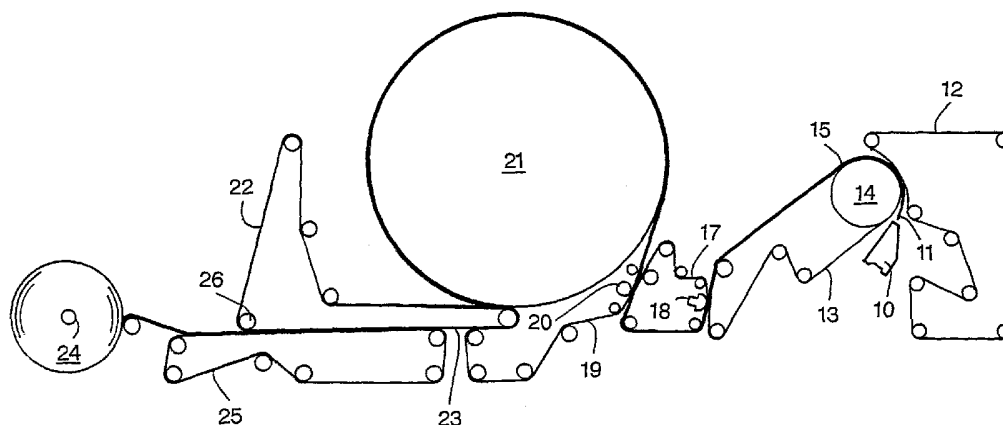

(57) Abstract: One embodiment of the present invention is an endless non-woven tissue making fabric having a three-dimensional texture suitable for use as a fabric for producing three-dimensional fibrous webs. The endless non-woven tissue making fabric comprises a plurality of substantially parallel adjoining sections of non-woven material. Each section of non-woven material has a width substantially less than the width of the non-woven tissue making fabric. Each section of non-woven material may be joined to at least one other adjoining section of non-woven material. The non-woven tissue making fabric has a machine direction, a cross-machine direction, a tissue contacting surface and a tissue machine contacting surface. The tissue contacting surface comprises solid matter at a plurality of heights such that the tissue contacting surface of the non-woven tissue making fabric has an Overall Surface Depth of at least 0.2 mm in regions of solid matter on the tissue contacting surface.

WO 2004/061218 A1

## **Non-woven Through Air Dryer and Transfer Fabrics for Tissue Making**

### **Background**

Fabrics used as through air drying and transfer fabrics in a tissue making process are typically woven endless fabrics manufactured using a tubular weaving technique or seaming a flat woven fabric into an endless structure. In either method of manufacturing, the weaving process is an expensive, complex, labor-  
5 intensive process. Developing new weaving patterns and materials that deliver the desired characteristics of the fabric and the tissue product can require a large investment of time and money. Additionally, there are physical constraints on the patterns and height differentials that may be woven on a loom, and there are further constraints on the runnability of fabrics so manufactured.

10

The use of substrates other than woven fabrics in the formation or drying of paper is known to a limited degree, such as non-fibrous monoplanar films and membranes used in the production of tissue. In tissue making, these structures typically offer flat, planar, non-fibrous regions for imprinting a web during a  
15 compression step in order to provide a network of densified regions surrounding undensified regions, with the densified regions providing strength and the undensified regions providing softness and absorbency. Such structures and processes lack the contoured, non-planar three-dimensionality that may be useful in producing textured and noncompressively dried materials and lack the intrinsic  
20 porosity and other properties found in fibrous materials. Such processes also result in a sheet with regions of high density and regions of low density, which is not suitable for some products. Further, substantially planar films are inherently limited in their ability to impart three-dimensional structures to a sheet.

25

Therefore, there is a need for improved tissue making fabrics capable of overcoming one or more of the limitations of previously known materials.

## Summary

The present invention is a non-woven tissue making fabric comprising a plurality of substantially parallel adjoining sections of non-woven material having a width less than the width of the non-woven tissue making fabric, the sections being joined together to form a non-woven tissue making fabric of sufficient strength and permeability to be suitable for use as a through-drying fabric, a forming fabric, an imprinting fabric, a transfer fabric, a carrier fabric, an impulse drying fabric, a pressing fabric or press felt, a drying fabric, a capillary dewatering belt, or other fabrics of use in tissue making or in the manufacture of other bulky fibrous webs such as airlaid webs, coform, nonwoven webs, and the like (such uses are encompassed in the general term "non-woven tissue making fabric," unless otherwise specified). The plurality of sections of nonwoven material may comprise a single fabric strip that is repeatedly wrapped in a substantially spiral manner to form parallel adjacent sections that can abut one another or overlap one another in successive turns to form a continuous loop of non-woven tissue making fabric having a width substantially greater than the width of the fabric strip of non-woven material. When a single fabric strip wrapped in a spiral manner is bonded to itself in regions of overlap for adjacent sections of the strip, the non-woven tissue making fabric is said to have a spirally continuous seam. In such a non-woven tissue making fabric, wherein each fabric strip of non-woven material has a first edge and an opposing second edge, the fabric strip of non-woven material is spirally wound in a plurality of contiguous turns such that the first edge in a turn of the fabric strip extends beyond the second edge of an adjacent turn of the fabric strip, forming a spirally continuous seam with adjacent turns of the fabric strip. In another embodiment, the first edge of the fabric strip in a turn may abut the second edge of the fabric strip in an adjacent turn.

A seam formed between the adjacent sides of parallel fabric strips or adjacent sections of a single spirally wound fabric strip may represent a region with higher basis weight or thickness when the non-woven materials of the adjacent fabric strips overlap. However, non-woven fabric strips may be used that have a tapered basis weight profile or thickness profile in the cross-direction, with lower

basis weight or thickness at or adjacent the first and/or second opposing edges. In this manner, two overlapping adjacent edges of adjacent fabric strips may result in a more uniform non-woven tissue making fabric because the region of overlap may have a less pronounced increase in thickness or basis weight, and may even yield  
5 a substantially uniform thickness or basis weight profile in the cross-direction of the non-woven tissue making fabric when the profiles of the individual fabric strips are suitably tailored.

In another embodiment, the plurality of sections of non-woven material may  
10 comprise a plurality of fabric strips that abut or overlap adjacent fabric strips. Seams may be formed by bonding adjacent fabric strips in regions of overlap or in regions where adjacent, non-overlapping fabric strips abut about their first and second opposing end edges, yielding a non-woven tissue making fabric that is said to have discontinuous seams. In yet another embodiment, the non-woven tissue  
15 making fabric may have regions where fabric strips abut one another and regions where the fabric strips overlap. For example, lower layers of fabric strips may overlap to provide good bond strength, while one or more upper layers of fabric strips may abut to provide a more uniform surface.

In still another embodiment, the non-woven tissue making fabric comprises  
20 a single fabric strip having at least one section substantially as wide as the non-woven tissue making fabric itself, and further comprising at least one other section having a width less than the non-woven tissue making fabric. Such a non-woven tissue making fabric may be made by spiral winding a fabric strip of non-woven  
25 material of a first width to form a multiply spiral wound structure, and then trimming the structure to a second width less than the first width. (Typically, this would be done in the machine direction.) In this case, some sections of the trimmed structure may have a width substantially less than the width of the non-woven tissue making fabric.

30

In another embodiment, the non-woven tissue making fabric comprises a  
least one fabric strip of non-woven material wound upon itself to form at least one region in the non-woven tissue making fabric having two superimposed plies of the

non-woven material bonded together, one above the other. Such a non-woven tissue making fabric may have a substantially heterogeneous basis weight distribution, with high basis weight regions coinciding with regions of self-overlap of the wound fabric strip of non-woven material, where two or more plies are  
5 superimposed. Such a non-woven tissue making fabric may be bonded together such that a nonlinear (discontinuous) seam region exists for improved fabric strength.

10 A single non-woven tissue making fabric may comprise more than one type of seam. For example, a spirally wound non-woven fabric strip may be joined with a plurality of non-spirally wound non-woven fabric strips, either in a plurality of separately formed layers or in more complex structures in which various fabric strips pass over or under each other.

15 The present invention is also a method of making a non-woven tissue making fabric. In one embodiment, a fabric strip of non-woven material having a first edge and an opposing second edge is provided. The fabric strip is spirally wound in a plurality of turns such that the first edge in a turn of the fabric strip extends beyond the second edge of an adjacent turn of the fabric strip. A spirally  
20 continuous seam is formed with adjacent turns of the fabric strip. In another embodiment, the first edge of the fabric strip in a turn may abut the second edge of the fabric strip in an adjacent turn.

In another embodiment, a plurality of fabric strips of one or more non-woven  
25 fabrics are aligned to be substantially parallel with each other but offset such that adjacent fabric strips either abut (adjoin without an overlapping rejoin) or overlap but not completely, and the adjoining strips are then bonded together to form a non-woven tissue making fabric. For embodiments of a non-woven tissue making fabric having a substantially three-dimensional tissue contacting surface  
30 (generally understood to be the web-contacting surface), the non-woven fabric strip may have been previously treated to have a three-dimensional surface structure, or the non-woven tissue making fabric may have been further treated to impart increased three-dimensional texture.

In another embodiment, a fabric strip of non-woven material is folded upon itself in a flattened helical pattern and bonded to form a non-woven tissue making fabric such that a tissue contacting surface of the non-woven tissue making fabric comprises substantially parallel abutting and/or overlapping sections of the non-woven material aligned with an axis at a first angle, and the inner layer (in some embodiments, the tissue machine contacting surface of the non-woven tissue making fabric opposite the tissue contacting surface of the non-woven tissue making fabric) comprises substantially parallel abutting or overlapping sections of the non-woven material aligned with an axis at a second angle, the first axis being a mirror image of the second axis reflected about the machine direction axis of the non-woven tissue making fabric.

In forming the non-woven tissue making fabrics of the present invention, a hierarchy of components may be defined employing the terms "ply," "layer," and "stratum." The non-woven tissue making fabric may comprise one or more distinct non-woven plies substantially as wide as the non-woven tissue making fabric itself, including at least one ply comprising a plurality of sections of non-woven material bonded together wherein neighboring sections abut or overlap to form one or more layers (e.g., when two neighboring sections overlap, the region of overlap has two layers; whereas abutting, non-overlapping parallel sections of non-woven fabric would form a single layer). In turn, each section or layer of non-woven material may itself comprise a plurality of joined-together strata (e.g., a unitary web formed by laying meltblown fibers onto a spunbond web would have two strata within the unitary web). In some embodiments, "section" and "strip" may be synonymous, while in some other embodiments hereafter described, a single fabric strip may form multiple sections, or a section may comprise multiple fabric strips joined together. A single fabric strip may also comprise multiple strata, which need not be completely coextensive, such that the edges of one stratum are not directly aligned with the edges of the adjacent stratum. The width of a ply, layer, stratum, strip, and/or section may have a width of less than the finished non-woven tissue making fabric, about the same width of the finished non-woven tissue making fabric, or have a width greater than the finished non-woven tissue making fabric.

The term "web" may refer to a ply, layer, or stratum in the above-mentioned hierarchy, depending on the context.

5           In some embodiments, a fabric strip of non-woven material may be spiral  
wound to form a section of non-woven material having a first width and regions  
having two layers of the fabric strips of non-woven material. The section may then  
be further spiral wound to form a ply having a second width greater than the first  
width. The resulting ply may then be joined to other non-woven plies or  
10 reinforcement plies to form a non-woven fabric strip, or the ply may be used as a  
non-woven tissue making fabric per se, and further provided with additional  
treatments as needed (e.g., edge reinforcement, perforations, three-dimensional  
molding, chemical finishing, foam bonding, point bonding, heat treatments, curing  
of adhesive components, electron beam treatments, corona discharge treatment,  
15 generation of electrets, needling, hydroneedling, hydroentangling, or treatment  
with surfactants, web lubricants, silicone agents, etc.).

          Joining any of these elements - plies, layers, or strata - to one another may  
be accomplished by any means known in the art. In addition to thermal bonding  
20 and its known variants involving the application of heat and pressure (e.g., point  
bonding, etc.), many other known methods may be used to join two materials  
together (e.g., joining superposed portions of two fabric strips in a region where  
one fabric strip abuts an adjacent fabric strip) or for joining one material to an  
underlying material. For example, hydroentangling or hydroneedling with jets of  
25 water may entangle fibers in one material with those of an adjoining material to  
attach the material. Illustrative methods are disclosed in U.S. Patent No.  
3,485,706, issued to Evans in 1969; U.S. Patent No. 3,494,821, issued to Evans  
in 1970; U.S. Patent No. 4,808,467, issued on February 28, 1989 to Suskind et al.;  
and, U.S. Patent No. 6,200,669, issued on March 13, 2001 to Marmon et al., all of  
30 which are herein incorporated by reference to the extent that they are non-  
contradictory herewith.

Coaperturing of two superposed webs of material (e.g., sections of non-woven material) may also be done, particularly coaperturing with heated pins that induce a degree of fusion of thermoplastic material in the webs of material in the vicinity of the aperture. Exemplary methods for coaperturing and equipment  
5 therefor are disclosed in U.S. Patent No. 5,986,167, issued on November 16, 1999 to Arteman et al. and U.S. Patent No. 4,886,632, issued on December 12, 1989 to Van Iten et al., both of which are herein incorporated by reference to the extent that they are non-contradictory herewith. Related methods also include perf-  
10 embossing, crimping of two or more webs of material, and embossing in general.

Joining these elements may also be achieved by the application of adhesive between the webs of material, such as a hot melt adhesive or adhesive meltblown, or binder material such as binder fibers added between adjoining webs of material followed by sufficient heating to fuse the binder material and join the webs of  
15 material, or other adhesives known in the art. Equipment and methods for adhesively joining two webs of material are taught in U.S. Patent No. 5,871,613, issued on February 16, 1999 to Bost et al.; U.S. Patent No. 5,882,573, issued on March 16, 1999 to Kwok et al.; and, U.S. Patent No. 5,904,298, issued on May 18, 1999 to Kwok et al., all of which are herein incorporated by reference to the extent  
20 that they are non-contradictory herewith. Hot melt or thermosetting adhesive applied by spray nozzles (including meltblowing methods) may be applied with such technologies. Photocurable adhesives may also be used, such as photocuring cyanoacrylates and acrylics described by P.J. Courtney, "Shedding  
25 New Light on Adhesives," *Adhesives Age*, February 2001, or the photocuring systems described in commonly owned U.S. Patent Application Serial No. 09/705,684, "Improved Deflection Members for Tissue Production," filed on November 3, 2000 by Lindsay et al., herein incorporated by reference to the extent that it is non-contradictory herewith.

30 Ultrasonic welding may be applied to join webs of material using rotary horns, ultrasonically activated pressing plates, or other devices. Equipment and methods useful for ultrasonic welding of nonwoven webs are disclosed in U.S. Patent No. 3,993,532, issued on November 23, 1976 to McDonald et al.; U.S.



Patent No. 4,659,614, issued on April 21, 1987 to Vitale; and, U.S. Patent No. 5,096,532, issued on March 17, 1992 to Neuwirth et al.

Other techniques may be applied, including, without limitation, application of  
5 electron beams to fuse adjacent fibers or to activate an adhesive; photocuring of  
resins contacting the fabric strips; through-air bonding; sewing of webs of material;  
application of rivets, staples, snaps, grommets, or other mechanical fasteners;  
hook-and-loop attachment means; or, mechanical needling of the web of material.  
Methods and equipment for joining nonwoven webs of material with mechanical  
10 needling are disclosed in U.S. Patent No. 5,713,399, issued on February 3, 1998  
to Collette et al.; U.S. Patent No. 3,729,785, issued on May. 1, 1973 to Sommer;  
U.S. Patent No. 3,890,681, issued on June 24, 1975 to Fekete et al.; U.S. Patent  
No. 4,962,576, issued on October 16, 1990 to Minichshofer et al.; and, U.S.  
Patent No. 5,511,294, issued on April 30, 1996 to Fehrer, as well as EP 1 063 349  
15 A2, published on December 27, 2000 in the name of Paquin, all of which are  
herein incorporated by reference to the extent that they are non-contradictory  
herewith. Needling (such as pin seaming) and aperturing, as well as other  
systems, have the potential to induce favorable changes in physical properties of  
the web of material such as increased permeability or improved fluid intake of the  
20 non-woven tissue making fabric.

When a hotmelt adhesive is used, the equipment for processing the hotmelt  
adhesive and supplying a stream of hotmelt adhesive to the printing systems of the  
present invention may be any known hotmelt or adhesive processing devices. For  
25 example, the ProFlex® applicators of Hot Melt Technologies, Inc. (Rochester,  
Michigan), the "S" Series Adhesive Supply Units of ITW Dynatec, Hendersonville,  
TN, as well as the DynaMelt "M" Series Adhesive Supply Units, the Melt-on-  
Demand Hopper, and the Hotmelt Adhesive Feeder, all of ITW Dynatec are all  
exemplary systems which may be used.

30

Binder materials may also be applied to one or more webs of material or  
portions thereof in the form of liquid resins, slurries, colloidal suspensions, or  
solutions that become rigid or crosslinked upon application of energy (e.g.,

microwave energy, heat, ultraviolet radiation, electron beam radiation, and the like). For example, Stypol XP44-AB12-51B of Freeman Chemical Corp., a diluted version of the Freeman 44-7010 binder, is a microwave-sensitive binder that was used by Buckley et al. in U.S. Patent No. 6,001,300, issued on December 14, 1999, previously incorporated by reference. Various types of thermosetting binders are known to the art such as polyvinyl acetate, vinyl acetate, ethylene-vinyl chloride, styrene butadiene, polyvinyl alcohol, polyethers, and the like. A heat-activated adhesive film is disclosed in EP 1 063 349 A2, published on December 27, 2000 in the name of Paquin, wherein it is herein incorporated by reference to the extent that it is not contradictory herewith.

As used herein, the term "non-woven" indicates that the material in question was produced without weaving techniques. Weaving processes produce a structure of individual strands which are interwoven generally in an identifiable repeating manner. Non-woven materials may be formed by a variety of processes such as meltblowing, spunbonding, and staple fiber carding. The term "non-woven" frequently refers to fibrous materials, but may also refer to non-fibrous material or webs that comprise non-fibrous materials, such as photocured resin elements or polymeric foams. However, in some embodiments, the non-woven materials of the present invention may be predominantly fibrous, or may be substantially free of non-fibrous protrusions on the paper-contacting side of the web. For example, the non-woven tissue making fabric of the present invention may comprise about 50 weight % or more fibrous non-woven materials, specifically about 70 weight % or more, more specifically about 80 weight % or more, more specifically still about 90 weight % or more, and most specifically about 95 weight % or more fibrous non-woven materials. In another embodiment, the non-woven tissue making fabrics may be substantially free of photocured polymeric resins, or substantially free of polymeric foams. Further, the non-woven tissue making fabrics of the present invention may be substantially free of elevated non-thermoplastic resinous elements on the tissue contacting surface of the non-woven tissue making fabric.

The non-woven tissue making fabric may be reinforced with added fabric strips of material where needed, including layers of scrim, tow, woven materials,

cured resins, and fabric strips of nonwoven material in any direction (e.g., lying in the cross-directional or machine directional or any direction therebetween).

5 The materials used may also vary with position in the non-woven tissue making fabric to obtain desirable material or mechanical properties. For example, the non-woven material may be polyester in most locations of the non-woven tissue making fabric, supplemented with polyphenylsulfide, polyether ether ketone, or a polyaramid at the side edges of the non-woven tissue making fabric to better resist hydrolysis, withstand elevated temperatures in a drying hood, or resist other  
10 mechanical or thermal challenges exacerbated at the side edges.

### **Brief Description of the Drawings**

15 **Figure 1** is a schematic of a papermaking apparatus.

**Figures 2A, 2B, and 2C** depict cross-sections of an embryonic web on a non-woven tissue making fabric.

20 **Figure 3** is a schematic view of a method for manufacturing a non-woven tissue making fabric of one embodiment of the present invention.

**Figure 4** is a schematic view of a molding section in a process for making a non-woven tissue making fabric according to one embodiment of the present invention.  
25

**Figure 5** is a schematic view of a rotating molding section in a process for making a non-woven tissue making fabric according to one embodiment of the present invention.

30 **Figure 6** is a schematic view of a rotating molding section in a process for making a two-ply non-woven tissue making fabric according to one embodiment of the present invention.

**Figure 7** is a schematic of a top view of a portion of a non-woven tissue making fabric according to the present invention having a plurality of fabric strips.

5 **Figures 8A** and **8B** are schematic views of embodiments of non-woven tissue making fabrics according to the present invention comprising a fabric strip that is wound in a plurality of turns at an acute angle to the machine direction.

10 **Figure 9** is a schematic view of a non-woven tissue making fabric of another embodiment of the present invention.

**Figure 10** is a schematic view of a non-woven tissue making fabric of another embodiment of the present invention.

15 **Figure 11** is a schematic view of a non-woven tissue making fabric of another embodiment of the present invention.

**Figure 12** is a schematic view of a non-woven tissue making fabric having discrete parallel fabric strips of non-woven material.

20 **Figure 13** is a cross-sectional view of the non-woven tissue making fabric of **Figure 12**, taken as indicated by line 13 - 13 in **Figure 12**.

25 **Figure 14** is a photograph of a three-dimensional drilled metal plate used to mold a section of a non-woven tissue making fabric according to the present invention.

**Figure 15** is a screen shot showing a topographic height map of a portion of the first metal plate and a characteristic profile extracted from the height map.

30 **Figure 16** is a screen shot showing a topographic height map of the first metal plate and a characteristic profile extracted from the height map.

**Figure 17** is a photograph of a two-ply non-woven tissue making fabric molded against the three-dimensional plate of **Figure 14**.

**Figure 18** is a screen shot showing a topographic height map of a portion of the non-woven tissue making fabric of **Figure 17**.

5

### Detailed Description

Referring to **Figure 1**, a process of carrying out using the present invention will be described in greater detail. The process shown depicts an uncreped  
10 through dried process, but it will be recognized that any known papermaking method or tissue making method can be used in conjunction with the non-woven tissue making fabrics of the present invention. Related uncreped through air dried tissue processes are described in U.S. Patent No. 5,656,132 issued on August 12, 1997 to Farrington et al. and in U.S. Patent No. 6,017,417 issued on January 25,  
15 2000 to Wendt et al. Both patents are herein incorporated by reference to the extent they are not contradictory herewith. Exemplary methods for the production of creped tissue and other paper products are disclosed in U.S. Patent No. 5,855,739, issued on January 5, 1999 to Ampulski et al.; U.S. Patent No. 5,897,745, issued on April 27, 1999 to Ampulski et al.; U.S. Patent No. 5,893,965,  
20 issued on April 13, 1999 to Trokhan et al.; U.S. Patent No. 5,972,813 issued on October 26, 1999 to Polat et al.; U.S. Patent No. 5,503,715, issued on April 2, 1996 to Trokhan et al.; U.S. Patent No. 5,935,381, issued on August 10, 1999 to Trokhan et al.; U.S. Patent No. 4,529,480, issued on July 16, 1985 to Trokhan; U.S. Patent No. 4,514,345, issued on April 30, 1985 to Johnson et al.; U.S. Patent  
25 No. 4,528,239, issued on July 9, 1985 to Trokhan; U.S. Patent No. 5,098,522, issued on March 24, 1992 to Smurkoski et al.; U.S. Patent No. 5,260,171, issued on November 9, 1993 to Smurkoski et al.; U.S. Patent No. 5,275,700, issued on January 4, 1994 to Trokhan; U.S. Patent No. 5,328,565, issued on July 12, 1994 to Rasch et al.; U.S. Patent No. 5,334,289, issued on August 2, 1994 to Trokhan  
30 et al. ; U.S. Patent No. 5,431,786, issued on July 11, 1995 to Rasch et al.; U.S. Patent No. 5,496,624, issued on March 5, 1996 to Stelljes, Jr. et al.; U.S. Patent No. 5,500,277, issued on March 19, 1996 to Trokhan et al.; U.S. Patent No. 5,514,523, issued on May 7, 1996 to Trokhan et al.; U.S. Patent No. 5,554,467,

issued on September 10, 1996, to Trokhan et al.; U.S. Patent No. 5,566,724,  
issued on October 22, 1996 to Trokhan et al.; U.S. Patent No. 5,624,790, issued  
on April 29, 1997 to Trokhan et al.; U.S. Patent No. 6,010,598, issued on January  
4, 2000 to Boutilier et al.; and, U.S. Patent No. 5,628,876, issued on May 13, 1997  
5 to Ayers et al., the specification and claims of which are incorporated herein by  
reference to the extent that they are not contradictory herewith.

In **Figure 1**, a twin wire former **8** having a papermaking headbox **10** injects  
or deposits a stream **11** of an aqueous suspension of papermaking fibers onto a  
10 plurality of forming fabrics, such as the outer forming fabric **12** and the inner  
forming fabric **13**, thereby forming a wet tissue web **15**. The forming process of the  
present invention may be any conventional forming process known in the  
papermaking industry. Such formation processes include, but are not limited to,  
Fourdriniers, roof formers such as suction breast roll formers, and gap formers  
15 such as twin wire formers and crescent formers.

The wet tissue web **15** forms on the inner forming fabric **13** as the inner  
forming fabric **13** revolves about a forming roll **14**. The inner forming fabric **13**  
serves to support and carry the newly-formed wet tissue web **15** downstream in the  
20 process as the wet tissue web **15** is partially dewatered to a consistency of about  
10 percent based on the dry weight of the fibers. Additional dewatering of the wet  
tissue web **15** may be carried out by known paper making techniques, such as  
vacuum suction boxes, while the inner forming fabric **13** supports the wet tissue  
web **15**. The wet tissue web **15** may be additionally dewatered to a consistency of  
25 at least about 20%, more specifically between about 20% to about 40%, and more  
specifically about 20% to about 30%. The wet tissue web **15** is then transferred  
from the inner forming fabric **13** to a transfer fabric **17** traveling preferably at a  
slower speed than the inner forming fabric **13** in order to impart increased MD  
stretch into the wet tissue web **15**.

30

The wet tissue web **15** is then transferred from the transfer fabric **17** to a  
throughdrying fabric **19** whereby the wet tissue web **15** may be macroscopically  
rearranged to conform to the surface of the throughdrying fabric **19** with the aid of

a vacuum transfer roll **20** or a vacuum transfer shoe like the vacuum shoe **18**. If desired, the throughdrying fabric **19** can be run at a speed slower than the speed of the transfer fabric **17** to further enhance MD stretch of the resulting absorbent tissue product **27**. The transfer may be carried out with vacuum assistance to  
5 ensure conformation of the wet tissue web **15** to the topography of the throughdrying fabric **19**.

While supported by the throughdrying fabric **19**, the wet tissue web **15** is dried to a final consistency of about 94 percent or greater by a throughdryer **21** and  
10 is thereafter transferred to a carrier fabric **22**. Alternatively, the drying process can be any noncompressive drying method that tends to preserve the bulk of the wet tissue web **15**.

The dried tissue web **23** is transported to a reel **24** using a carrier fabric **22**  
15 and an optional carrier fabric **25**. An optional pressurized turning roll **26** can be used to facilitate transfer of the dried tissue web **23** from the carrier fabric **22** to the carrier fabric **25**. If desired, the dried tissue web **23** may additionally be embossed to produce a pattern on the absorbent tissue product **27** produced using the throughdrying fabric **19** and a subsequent embossing stage.

20  
Once the wet tissue web **15** has been non-compressively dried, thereby forming the dried tissue web **23**, it is possible to crepe the dried tissue web **23** by transferring the dried tissue web **23** to a Yankee dryer prior to reeling, or using alternative foreshortening methods such as microcreping as disclosed in U.S.  
25 Patent No. 4,919,877 issued on April, 24, 1990 to Parsons et al.

In an alternative embodiment not shown, the wet tissue web **15** may be transferred directly from the inner forming fabric **13** to the throughdrying fabric **19** and the transfer fabric **17** eliminated. The throughdrying fabric **19** may be traveling  
30 at a speed less than the inner forming fabric **13** such that the wet tissue web **15** is rush transferred, or, in the alternative, the throughdrying fabric **19** may be traveling at substantially the same speed as the inner forming fabric **13**. If the throughdrying fabric **19** is traveling at a slower speed than the speed of the inner forming fabric

13, an uncreped absorbent tissue product 27 is produced. Additional foreshortening after the drying stage may be employed to improve the MD stretch of the absorbent tissue product 27. Methods of foreshortening the absorbent tissue product 27 include, by way of illustration and without limitation, conventional  
5 Yankee dryer creping, microcreping, or any other method known in the art.

Differential velocity transfer from one fabric to another can follow the principles taught in any one of the following patents, each of which is herein incorporated by reference to the extent it is not contradictory herewith: U.S. Patent  
10 No. 5,667,636, issued on September 16, 1997 to Engel et al.; U.S. Patent No. 5,830,321, issued on November 3, 1998 to Lindsay et al.; U.S. Patent No. 4,440,597, issued on April 3, 1984 to Wells et al.; U.S. Patent No. 4,551,199, issued on November 5, 1985 to Weldon; and, U.S. Patent No. 4,849,054, issued on July 18, 1989 to Klowak.

15

In yet another alternative embodiment of the present invention, the inner forming fabric 13, the transfer fabric 17, and the throughdrying fabric 19 can all be traveling at substantially the same speed. Foreshortening may be employed to improve MD stretch of the absorbent tissue product 27. Such methods include, by  
20 way of illustration without limitation, conventional Yankee dryer creping or microcreping.

Any known papermaking or tissue manufacturing method may be used to create a web 23 using the non-woven tissue making fabrics 30 of the present  
25 invention. Though the non-woven tissue making fabrics 30 of the present invention are especially useful as transfer and through drying fabrics and can be used with any known tissue making process that employs throughdrying, the non-woven tissue making fabrics 30 of the present invention can also be used in the formation of wet tissue webs 15 as forming fabrics, carrier fabrics, drying fabrics, imprinting  
30 fabrics, and the like in any known papermaking or tissue making process. Such methods can include variations comprising any one or more of the following steps in any feasible combination:



- wet tissue web formation in a wet end in the form of a classical Fourdrinier, a gap former, a twin-wire former, a crescent former, or any other known former comprising any known headbox, including a stratified headbox for bringing layers of two or more furnishes together into a single tissue web, or a plurality of headboxes for forming a multi-layered tissue web, using known wires and fabrics or the non-woven tissue making fabrics **30** of the present invention;
- wet tissue web formation or wet tissue web dewatering by foam-based processes, such as processes wherein the fibers are entrained or suspended in a foam prior to dewatering, or wherein foam is applied to an embryonic wet tissue web prior to dewatering or drying, including the methods disclosed in U.S. Patent 5,178,729, issued on January 12, 1993 to Janda, and U.S. Patent No. 6,103,060, issued on August 15, 2000 to Munerelle et al., both of which are herein incorporated by reference to the extent they are not contradictory herewith;
- differential basis weight formation by draining a slurry through a forming fabric having high and low permeability regions, including the non-woven tissue making fabrics **30** of the present invention or any known forming fabric;
- rush transfer of a wet tissue web from a first fabric to a second fabric moving at a slower velocity than the first fabric, wherein the first fabric can be a forming fabric, a transfer fabric, or a throughdrying fabric, and wherein the second fabric can be a transfer fabric, a throughdrying fabric, a second throughdrying fabric, or a carrier fabric disposed after a throughdrying fabric (one exemplary rush transfer process is disclosed in U.S. Patent No. 4,440,597, issued on April 3, 1984 to Wells et al., herein incorporated by reference to the extent that it is non-contradictory herewith), wherein the aforementioned fabrics can be selected from any suitable fabrics known in the art or the non-woven tissue making fabrics **30** of the present invention;
- application of differential air pressure across the wet tissue web to mold it into one or more of the fabrics on which the wet tissue web rests, such as using a high vacuum pressure in a vacuum transfer roll or transfer shoe to mold a wet tissue web into a throughdrying fabric as it is transferred from a forming fabric or intermediate carrier fabric, wherein the carrier fabric, throughdrying fabric, or

other fabrics can be selected from the non-woven tissue making fabrics 30 of the present invention or other fabrics known in the art;

- use of an air press or other gaseous dewatering methods to increase the dryness of a tissue web and/or to impart molding to the tissue web, as disclosed in U.S. Patent No. 6096169, issued on August 1, 2000 to Hermans et al.; U.S. Patent No. 6,197,154, issued on March 6, 2001 to Chen et al.; and, U.S. Patent No. 6,143,135, issued on November 7, 2000 to Hada et al., all of which are herein incorporated by reference to the extent they are not contradictory herewith;
- drying the wet tissue web by any compressive or noncompressive drying process, such as throughdrying, drum drying, infrared drying, microwave drying, wet pressing, impulse drying (e.g., the methods disclosed in U.S. Patent No. 5,353,521, issued on October 11, 1994 to Orloff and U.S. Patent No. 5,598,642, issued on February 4, 1997 to Orloff et al.), high intensity nip dewatering, displacement dewatering (see J.D. Lindsay, "Displacement Dewatering To Maintain Bulk," *Paperi Ja Puu*, vol. 74, No. 3, 1992, pp. 232-242), capillary dewatering (see any of U.S. Patent Nos. 5,598,643; 5,701,682; and 5,699,626, all of which issued to Chuang et al.), steam drying, etc.
- printing, coating, spraying, or otherwise transferring a chemical agent or compound on one or more sides of the wet tissue web uniformly or heterogeneously, as in a pattern, wherein any known agent or compound useful for a web-based product can be used (e.g., a softness agent such as a quaternary ammonium compound, a silicone agent, an emollient, a skin-wellness agent such as aloe vera extract, an antimicrobial agent such as citric acid, an odor-control agent, a pH control agent, a sizing agent; a polysaccharide derivative, a wet strength agent, a dye, a fragrance, and the like), including the methods of U.S. Patent No. 5,871,763, issued on February 16, 1999 to Luu et al.; U.S. Patent No. 5,716,692, issued on February 10, 1998 to Warner et al.; U.S. Patent No. 5,573,637, issued on November 12, 1996 to Ampulski et al.; U.S. Patent No. 5,607,980, issued on March 4, 1997 to McAtee et al.; U.S. Patent No. 5,614,293, issued on March 25, 1997 to Krzysik et al.; U.S. Patent No. 5,643,588, issued on July 1, 1997 to Roe et al.; U.S. Patent No. 5,650,218, issued on July 22, 1997 to Krzysik et al.; U.S. Patent

No. 5,990,377, issued on November 23, 1999 to Chen et al.; and, U.S. Patent No. 5,227,242, issued on July 13, 1993 to Walter et al., each of which is herein incorporated by reference to the extent they are not contradictory herewith;

- 5 • imprinting the wet tissue web on a Yankee dryer or other solid surface, wherein the wet tissue web resides on a fabric that can have deflection conduits (openings) and elevated regions (including the fabrics of the present invention), and the fabric is pressed against a surface such as the surface of a Yankee dryer to transfer the wet tissue web from the fabric to the surface of the Yankee dryer, thereby imparting densification to portions of the wet tissue web that  
10 were in contact with the elevated regions of the fabric, whereafter the selectively densified dried tissue web can be creped from or otherwise removed from the surface of the Yankee dryer;
- creping the dried tissue web from a drum dryer, optionally after application of a strength agent such as latex to one or more sides of the tissue web, as  
15 exemplified by the methods disclosed in U.S. Patent No. 3,879,257, issued on April 22, 1975 to Gentile et al.; U.S. Patent No. 5,885,418, issued on March 23, 1999 to Anderson et al.; U.S. Patent No. 6,149,768, issued on November 21, 2000 to Hepford, all of which are herein incorporated by reference to the extent they are not contradictory herewith;
- 20 • creping with serrated crepe blades (e.g., see U.S. Patent No. 5,885,416, issued on March 23, 1999 to Marinack et al.) or any other known creping or foreshortening method; and,
- converting the tissue web with known operations such as calendering, embossing, slitting, printing, forming a multiply structure having two, three, four,  
25 or more plies, putting on a roll or in a box or adapting for other dispensing means, packaging in any known form, and the like.

The present invention resides in a process for making tissue wherein the fibrous tissue web, prior to complete drying, transferred onto a non-woven tissue  
30 making fabric **30** comprising at least one layer of a porous synthetic polymeric, ceramic, or metallic non-woven material **31** in contact with the wet tissue web **15**. An embodiment of such a non-woven tissue making fabric **30** is shown in **Figures 2A** and **2B**, showing a cross-section of a porous non-woven tissue making fabric

**30** with an embryonic wet tissue web **15** superposed thereon, such as a tissue web in the process of being through-air dried on the three-dimensional non-woven tissue making fabric **30** as depicted. As shown in **Figure 2A**, the tissue making fabric **30** comprises a ply of non-woven material **31**. In **Figure 2B**, the non-woven tissue making fabric **30** comprises a first ply of non-woven material **31a** joined to an underlying second ply of non-woven material **31b**. Alternatively, the second ply **31b** may be replaced with a woven layer (not shown). Alternatively, the first ply of non-woven material **31a** may be replaced with a three-dimensional woven layer which may comprise the tissue contacting surface of the resulting tissue making fabric **30**.

In other embodiments of the present invention (not shown), the tissue making fabric **30** may comprise a ply of non-woven material **31** and a ply of woven material. The non-woven tissue making fabric **30** may comprise a first ply of woven material joined to an underlying second ply of non-woven material **31b**.

In **Figure 2C**, a lower non-woven ply **31b** has been provided with elevated non-woven photocured deflection elements **33** defining an upper layer **31a** of non-woven material. The deflection elements **33** have openings **37** therebetween (deflection conduits) into which the wet tissue web **15** may be deflected in the presence of an air pressure differential or by pressing operations to create a three-dimensional effect in the wet tissue web **15**. The deflection elements **33**, as shown are asymmetrical, have a three-dimensional topography (as opposed to flat or macroscopically monoplanar deflection elements), according to the teachings in commonly owned U.S. Patent Application Serial No. 09/705684, previously incorporated by reference, but symmetrical deflection elements may also be used. The deflection elements **33** may be part of a continuous network or may be isolated islands of photocured resin. The deflection elements **33** need not be impervious, but may comprise a plurality of pores through which gas can flow. For example, the deflection elements **33** may comprise an open-celled foam or other porous material. The deflection elements **33** need not be photocured, but may be cured by free radical polymerization, thermosetting, electron beam curing, ultrasonic curing, and other methods known in the art.

Regarding **Figure 2C**, the three-dimensional features of the non-woven tissue making fabric **30**, in general may comprise non-fibrous polymeric protrusions or an elevated polymeric network, created by applying a layer of photocurable resin to a ply of non-woven material **31b**, then selectively photocuring portions of the resin by application of actinic or other radiation through a mask to create a pattern or network of cured resin, followed by removal of uncured resin, to create a photocured layer attached to an underlying layer or ply of material. Exemplary methods for such processes are disclosed in U.S. Patent No. 6,420,100, issued on July 16, 2002 to Trokhan et al. and U.S. Patent No. 5,817,377, issued on October 6, 1998 to Trokhan et al., both of which are herein incorporated by reference to the extent that they are non-contradictory herewith, as well as U.S. Patent No. 4,514,345, issued on April 30, 1985 to Johnson et al. and U.S. Patent No. 5,334,289, issued on August 2, 1994 to Trokhan et al., both of which were previously incorporated by reference. Further improvements in these methods have been disclosed by Lindsay et al. in commonly owned U.S. Patent Application Serial No. 09/705684, herein incorporated by reference to the extent that it is non-contradictory herewith.

The topography of the non-woven tissue making fabric **30** in **Figure 2C** illustrates a feature that is possible in many of the embodiments of the present invention, namely, that the surface of the non-woven tissue making fabric **30** need not be monoplanar, but can have a complex topography with raised and depressed elements at a variety of heights (e.g., raised elements at two or more heights relative to the plane of an underlying layer). The wet tissue web **15** through-dried on such a non-woven tissue making fabric **30** may have a complex topography as well, with an Overall Surface Depth of about 0.2 mm or greater, more specifically about 0.3 mm or greater, and most specifically about 0.4 mm or greater. "Overall Surface Depth," described more fully hereafter, is a measure of the topography of a surface, indicative of a characteristic height different between elevated and depressed portions of the surface of the non-woven tissue making fabric **30**. The Overall Surface Depth of non-apertured portions of the non-woven tissue making fabric **30** may likewise be about 0.2 mm or greater, more specifically about 0.3 mm

or greater, and most specifically about 0.4 mm or greater. In some embodiments, even greater ranges are possible, such as about 0.5 mm or greater (e.g., from about 0.5 mm to about 3 mm or from about 0.5 mm to about 2 mm), more specifically about 0.8 mm or greater, and most specifically about 1.5 mm or greater.

5 The thickness of the non-woven tissue making fabric **30** may be about 1 mm or greater, more specifically about 3 mm or greater, most specifically about 6 mm or greater, and may be about 10 mm or less, about 7 mm or less, or about 5 mm or less.

10 It is understood that in the structures shown in **Figures 2A, 2B, and 2C**, the tissue machine contacting surface **50** may have a topography substantially independent of the topography of the tissue contacting surface **51**. The non-woven tissue making fabric **30** may have a relatively uniform basis weight; low density, high caliper regions; high density, low caliper regions; high basis weight  
15 regions alternating with low basis weight regions; and/or, combinations thereof.

When the non-woven tissue making fabric **30** comprises more than one layer, as it does in **Figures 2B and 2C**, each layer of non-woven material **31a** and **31b** in the non-woven tissue making fabric **30** (or the entire non-woven material **31**  
20 as depicted in **Figure 2A**) may independently be in the form of fibrous mats or webs of material, such as bonded carded webs, airlaid webs, scrim, needled webs, extruded net-works, and the like, or foams, which may be open cell or reticulated foams, as well as extruded foams, including extruded polyurethane foams. Suitable polymers may comprise polyester, polyurethane, vinyl, acrylic,  
25 polycarbonates, nylon, polyamides (e.g., nylon 6, nylon 66, etc.), polyethylene, polypropylene, polybutylene terephthalate (PBT), polyphenylsulfide (PPS), Nomex® or Kevlar® (both manufactured by DuPont), syndiotactic polystyrene, polyacrylonitrile, phenolic resins, polyvinyl chloride, polymethacrylates, polymethacrylic acids, polyether ether ketone (PEEK), and the like, as well as  
30 copolymers and homopolymers thereof. Useful polymers may also include liquid crystal polymers (e.g., polyesters) and other high-temperature polymers and specialty polymers, such as those available from Ticona Corp. (Summit, New Jersey), including Vectra™; Celanex® or Vandar® thermoplastic polyester;

Riteflex® thermoplastic polyester elastomer; long fiber reinforced thermoplastics such as Compel®, Celstran®, and Fiberod® products; Topas® cyclic-olefin copolymer; Duracon®, Celcon®, and Hostaform® acetal copolymers; Fortron® polyphenylene sulfide; and, Duranex™ thermoplastic polyester (PBT). For fibrous mats of material, the non-woven materials **31** may be either the synthetic polymers mentioned above or optionally a bulky ceramic material such as fiberglass or fibrous ceramic materials commonly used as filters or insulating material, including alumina or silicate structures produced by Thermal Ceramics, Inc. of Augusta, Ga., in the form of wet laid or air laid fiber mats, or may comprise composite fibers with mineral and synthetic components, or carbon fibers.

The non-woven material **31** may be stable to temperatures at or above about 110°C., specifically at or above about 130°C., more specifically at or above about 150°C., more specifically at or above about 170°C., and most specifically at or above about 190°C, in order to ensure a suitable life-time under intense drying conditions. Commercial polymeric fibers known for temperature resistance include polyesters; aramids, such as Nomex® fibers, manufactured by DuPont, Inc.; polyphenylsulfide; polyether ether ketone, PEEK such as having a glass transition temperature of 142°C or 288°F; and, the like. For durability at elevated temperatures, the glass transition temperature may be at or above about 60°C, such as about 80°C or greater, specifically about 100°C or greater, more specifically about 110°C or greater, and most specifically about 120°C or greater. Typically, the non-woven material **31** is sufficiently gas permeable throughout the breadth of the substrate such that no roughly circular region about 2.5 mm in diameter or greater, specifically about 1.5 mm in diameter or greater, more specifically about 0.9 mm in diameter or greater, and most specifically about 0.5 mm in diameter or greater will be substantially blocked from air flow under conditions of differential air pressure across the substrate with a pressure differential of about 0.1 psi or greater at a temperature of about 25 °C.

30

The non-woven material **31** depicted in **Figure 2A** (or the plies of non-woven materials **31a** and **31b** depicted in **Figures 2B** and **2C**, hereafter generally understood to be comprised by reference to the non-woven material **31**) may be

reinforced by additional plies of non-woven material, scrim material, woven webs, polymeric or metallic filaments, and the like. Such reinforcing elements may be away from the paper-contacting side of the non-woven tissue making fabric, or do not form elevated regions that could affect the topography of the tissue web  
5 produced thereon.

In some embodiments, the non-woven tissue making fabric **30** is free of woven components, or, more specifically, does not have a ply or layer of woven polymeric filaments. In another embodiment, the non-woven tissue making fabric  
10 **30** consists essentially of non-woven materials **31** and means for binding the non-woven materials **31** one to another. In other embodiments of the present invention, the non-woven tissue making fabric **30** may comprise woven components and/or photocured elements. The woven components and/or photocured elements may comprise the tissue contacting surface **51** and/or the tissue machine contacting  
15 surface **50** and/or any portion therebetween of the non-woven tissue making fabric **30**.

The non-woven material **31** may be intrinsically gas permeable to permit drying and molding of the wet tissue web **15** onto the non-woven tissue making  
20 fabric **30** by air flow through the wet tissue web **15** and the non-woven tissue making fabric **30**. The permeability and/or porosity of a non-woven tissue making fabric **30** may be increased, if desired, by any method known in the art. For example, the non-woven material **31** may be provided with numerous holes or apertures (not shown), or selected regions of the non-woven tissue making fabric  
25 **30** may be thinned to decrease the resistance to air flow offered by the non-woven material **31**. Such treatments can be applied before, after, or simultaneously with bonding of adjacent fabric strips **34** of the non-woven material **31**. Specific operations for increasing the permeability of the non-woven material **31** and/or the non-woven tissue making fabric **30** include hot-pin aperturing, perf-embossing,  
30 cutting, drilling, debonding, needling, laser drilling, laser ablation, hydroentangling or general impact with high velocity jets or droplets of water or other liquids to rearrange fibers in the non-woven material **31**, mechanical abrasion, peening the non-woven material **31** or impacting it with particles that pierce the non-woven



material **31** or cause the non-woven material **31** to be relatively more open, and the like. Such non-woven material **31** and/or the non-woven tissue making fabric **30** may be manufactured such that the non-woven tissue making fabric **30** results in a more uniform drying rate and/or profile. In addition, the non-woven material **31** and/or the non-woven tissue making fabric **30** may be manufactured such that the non-woven tissue making fabric **30** provides more uniform air permeability characteristics.

Obviously, holes and apertures of various sizes may be provided in the layer of the non-woven material **31**, but if they are used, the air pressure differential during transfer and through drying should be low enough to prevent excessive puncturing of the wet tissue web **15** over the apertures.

As used herein, the "Air Permeability" of the non-woven tissue making fabric **30** or the non-woven material **31** may be measured with the FX 3300 Air Permeability device manufactured by Textest AG (Zürich, Switzerland), set to a pressure of 125 Pa with the normal 7-cm diameter opening (38 square centimeters area), which gives readings of Air Permeability in cubic feet per minute (CFM) that are comparable to well-known Frazier Air Permeability measurements. The Air Permeability value for the non-woven tissue making fabric **30** or for the non-woven material **31** thereof (or any non-woven ply of the non-woven tissue making fabric **30**) may be about 30 CFM or greater, such as any of the following values (about or greater): 50 CFM, 70 CFM, 100 CFM, 150 CFM, 200 CFM, 250 CFM, 300 CFM, 350 CFM, 400 CFM, 450 CFM, 500 CFM, 550 CFM, 600 CFM, 650 CFM, 700 CFM, 750 CFM, 800 CFM, 900 CFM, 1000 CFM, and 1100 CFM. Exemplary ranges include from about 200 CFM to about 1400 CFM, from about 300 CFM to about 1200 CFM, and from about 100 CFM to about 800 CFM. For some applications, low Air Permeability may be desirable. Thus, the Air Permeability of the non-woven tissue making fabric **30** may be about 500 CFM or less, about 400 CFM or less, about 300 CFM or less, or about 200 CFM or less, such as from about 30 CFM to about 150 CFM, and from about 0 CFM to about 50 CFM. Substantially water impervious or substantially air impervious non-woven tissue

making fabrics **30** (or both air and liquid impervious fabrics) are within the scope of the present invention when no through-flow of fluid is needed.

The structure of the non-woven material **31** of the present invention may  
5 provide for a faster throughdrying rate at a given Air Permeability. Non-woven  
tissue making fabrics **30** may provide a more uniform basis weight network of  
small diameter fibers, more numerous, smaller orifices, and a higher fiber support  
tissue contacting surface **51**. There more numerous, smaller orifices are  
anticipated to result in more numerous drying fronts in the wet tissue web **15**  
10 during throughdrying. The higher fiber support tissue contacting surface **51** is  
anticipated to result in fewer pinholes in the wet tissue web **15** during molding and  
throughdrying. The combination of more numerous drying fronts and fewer  
pinholes in the wet tissue web **15** during throughdrying is anticipated to result in a  
faster throughdrying rate at a given air permeability, or require less air permeability  
15 than conventional woven fabrics for a given throughdrying rate.

The non-woven material **31** may have sufficient resilience to maintain a  
three-dimensional structure under vacuum or pneumatic pressure levels typical of  
through drying or impingement drying. However, the non-woven material **31** may  
20 also have a degree of compressibility to permit deformation during mechanical  
loading or shear such that highly elevated elements on the surface of the non-  
woven material **31** or the resulting non-woven tissue making fabric **30** may deform  
without causing damage to the wet tissue web **15** during contact with another  
surface, as occurs during typical web transfer events, pressing events,  
25 watermarking, or transfer to a can dryer. While non-compressive drying may be  
valuable in some applications, compressive drying and pressing is also within the  
scope of the present invention. Further, even in non-compressive drying, it is  
recognized that somewhat compressive events may occur prior to drying or during  
normal wet handling operations which may have the effect of pressing or shearing  
30 a wet tissue web **15**. During such operations, a wet tissue web **15** on a highly  
contoured substrate with high surface depth might suffer damage as only a small  
fraction of the wet tissue web **15** at the most elevated points might be required to  
bear the load, shear stress, or friction of the operation. Compressible deflection

elements **33** may also help alleviate stress in the wet tissue web **15** during treatment by differential air pressure as stressed regions of the non-woven tissue making fabric **30** deform and distribute the stress to broader regions of the non-woven tissue making fabric **30**.

5

Low Pressure Compressive Compliance of a non-woven material **31** may be measured by compressing a substantially planar sample of the non-woven material **31** having a basis weight above 50 gsm with a weighted platen of 3-inches in diameter to impart mechanical loads of 0.05 psi and then 0.2 psi, measuring the  
10 thickness of the sample while under such compressive loads. Subtracting the ratio of thickness at 0.2 psi to thickness at 0.05 psi from 1 yields the Low Pressure Compressive Compliance, or Low Pressure Compressive Compliance =  $1 -$   
(thickness at 0.2 psi/thickness at 0.05 psi). The Low Pressure Compressive Compliance should be about 0.05 or greater, specifically about 0.1 or greater,  
15 more specifically about 0.2 or greater, still more specifically about 0.3 or greater, and most specifically between about 0.2 and about 0.5.

High Pressure Compressive Compliance is measured using a pressure range of 0.2 and 2.0 psi in making the determination of compliance, otherwise  
20 performed as for Low Pressure Compressive Compliance. In other words, High Pressure Compressive Compliance =  $1 -$  (thickness at 2.0 psi/thickness at 0.2 psi). The High Pressure Compressive Compliance should be about 0.05 or greater, specifically about 0.15 or greater, more specifically about 0.25 or greater, still more specifically about 0.35 or greater, and most specifically between about 0.1 and  
25 about 0.5.

A non-woven material **31** potentially suitable for the present invention is the polyurethane foam applied to a papermaking fabric as disclosed in U.S. Patent No. 5,512,319, issued on April 30, 1996 to Cook et al., herein incorporated by  
30 reference to the extent that it is non-contradictory herewith. Also of relevance to the present invention are the related papermaking fabrics by Voith Fabrics (Appleton, Wisconsin), sold under the trade names "SPECTRA" and "Olympus." The SPECTRA fabrics incorporate a polyurethane membrane on an underlying

woven papermaking fabric or batt. Alternatively, related fabrics may consist entirely of extruded material. The sales literature on these composite fabrics shows the network to be largely planar with holes or apertures imparted by the extrusion process. However, the manufacturing process could be modified to  
5 create a more contoured, three-dimensional surface of varying height more suitable for the non-woven tissue making fabrics **30** of the present invention.

Also of potential use is the "Ribbed Spectra" design comprising two polyurethane regions of differing height. Such engineered fabrics have the  
10 potential to allow a wide range of three-dimensional structures to be achieved in a papermaking fabric. These fabrics are sold for use in pressing and forming, but for the present invention could be adapted for through drying. The technology may be limited to producing several discrete planar regions which differ in height. More three-dimensional or textured variations of the SPECTRA structures may be  
15 obtained by regulating the amount of resin applied to various regions of the composite fabric to yield a heterogeneous basis weight distribution to provide regions of varying height. Another method is carving or further shaping an existing composite fabric before or after hardening of the resin. For example, the structures can be modified by pressing against another textured surface before full  
20 hardening, or by selective abrasion, sanding, laser drilling, or other forms of mechanical removal of portions of the structure before or after hardening.

Several general methods may be applied to create three-dimensional non-woven tissue making fabrics **30** such as those of **Figures 2A-2C**. Photocuring of  
25 resins on a substrate has been previously discussed. In other embodiments, if a layer of the non-woven material **31** is attached to an woven underlying porous member **32** (not shown), the three-dimensional shaping of the layer (or layers) of non-woven material **31** may be carried out before or after attachment to the woven underlying porous member **32**. In particular, the layer of non-woven material **31**  
30 may be given a three-dimensional structure by establishment of a heterogeneous basis weight distribution during forming or by post-processing which adds or removes material from the non-woven material **31** at desired locations. When additional material is added to a layer of non-woven material **31**, such as a

relatively uniform or planar layer, to thereby create a three-dimensional surface, the added material may be of a composition or nature other than that used to create the layer of non-woven material **31**. Such composite three-dimensional non-woven tissue making fabrics **30** are within the scope of the present invention.

5 For example, such a composite may comprise a first layer of a synthetic fibrous mat of non-woven material **31** in contact with an woven base fabric underlying porous member **32**, with a second layer of non-woven material **31** such as a polyurethane foam or reticulated foam added to the exposed surface of selected regions of said first layer of non-woven material **31**. The resulting composite non-  
10 woven tissue making fabric **30** may have heterogeneous basis weight, density, and/or chemical composition.

In another embodiment, a three-dimensional topography may be imparted to an upper ply by adding material heterogeneously between the upper ply and a  
15 neighboring lower ply (not shown) of the non-woven material **31**. For example, beads of adhesive, pieces of foam, or cut pieces of non-woven material interposed between two neighboring plies of the non-woven material **31** may impart a three-dimensional structure to the upper ply.

20 There are several methods of producing fibers or filaments that may be used in the non-woven material **31** of the non-woven tissue making fabric **30** of the present invention; however, two commonly used processes are known as spunbonding and meltblowing and the resulting non-woven webs are known as spunbond and meltblown webs, respectively. As used herein, polymeric fibers and  
25 filaments are referred to generically as polymeric strands. In the context of non-woven webs, the terms "filaments" refers to continuous strands of material while the term "polymeric fibers" refers to cut or discontinuous strands having a definite length.

30 Generally described, the process for making spunbond non-woven webs includes extruding thermoplastic material through a spinneret and drawing the extruded material into filaments with a stream of high-velocity air to form a random web on a collecting surface. Such a method is referred to as meltspinning.

Spunbond processes are generally defined in numerous patents including, for example, U.S. Patent No. 3,692,618, issued on September 19, 1972 to Dorschner, et al.; U.S. Patent No. 4,340,563, issued on July 20, 1982 to Appel, et al.; U.S. Patent No. 3,338,992, issued on August 29, 1967 to Kinney; U.S. Patent No. 3,341,394, issued on September 12, 1967 to Kinney; U.S. Patent No. 3,502,538, issued on March 24, 1970 to Levy; U.S. Patent No. 3,502,763, issued on March 24, 1970 to Hartmann; U.S. Patent No. 3,542,615, issued on November 24, 1970 to Dobo, et al.; and, Canadian Patent No. 803,714, issued on January 14, 1969 to Harmon.

10

On the other hand, meltblown non-woven webs are made by extruding a thermoplastic material through one or more dies, blowing a high-velocity stream of air past the extrusion dies to generate an air-conveyed melt-blown fiber curtain and depositing the curtain of fibers onto a collecting surface to form a random non-woven web. Meltblowing processes are generally described in numerous publications including, for example, an article titled "Superfine Thermoplastic Fibers" by Wendt in Industrial and Engineering Chemistry, Vol. 48, No. 8, (1956), at pp. 1342-1346, which describes work done at the Naval Research Laboratories in Washington, D.C.; Naval Research Laboratory Report 111437, dated Apr. 15, 1954; U.S. Patent No. 4,041,203, issued on August 9, 1977 to Brock et al.; U.S. Patent No. 3,715,251, issued on February 6, 1973 to Prentice; U.S. Patent No. 3,704,198, issued on November 28, 1972 to Prentice; U.S. Patent No. 3,676,242, issued on July 11, 1972 to Prentice; and, U.S. Patent No. 3,595,245, issued on July 27, 1971 to Buntin et al. as well as British Specification No. 1,217,892, published on December 31, 1970.

25

Spunbond and meltblown non-woven webs are usually distinguished by the diameters and the molecular orientation of the filaments or fibers which form the webs. The diameter of spunbond and meltblown filaments or fibers is the average cross-sectional dimension. Spunbond filaments or fibers typically have average diameters of about 6 microns or greater and often have average diameters in the range of about 15 to about 40 microns. Meltblown fibers typically have average diameters of about 15 microns or less and more specifically about 6 microns or

30

less. However, because larger meltblown fibers, having diameters of about 6 microns or greater may also be produced, molecular orientation may be used to distinguish spunbond and meltblown filaments and fibers of similar diameters.

5           In the present invention, the average diameters of the filaments or fibers may be about 20 microns or greater, more specifically about 50 microns or greater, more specifically about 100 microns or greater, and most specifically about 300 microns or greater. The average diameters of the filaments or fibers may range from about 6 to about 700 microns, more specifically about 20 to about 500  
10          microns, more specifically about 30 to about 300 microns, more specifically about 50 to about 200 microns, and most specifically about 100 microns.

          For a given fiber or filament size and polymer, the molecular orientation of a spunbond fiber or filament is typically greater than the molecular orientation of a  
15          meltblown fiber. Relative molecular orientation of polymeric fibers or filaments can be determined by measuring the tensile strength and birefringence of fibers or filaments having the same diameter. Tensile strength of fibers and filaments is a measure of the stress required to stretch the fiber or filament until the fiber or filament breaks. Birefringence numbers are calculated according to the method  
20          described in the spring 1991 issue of *INDA Journal of Nonwovens Research*, (Vol. 3, No. 2, p. 27). The tensile strength and birefringence numbers of polymeric fibers and filaments vary depending on the particular polymer and other factors; however, for a given fiber or filament size and polymer, the tensile strength of a spunbond fiber or filament is typically greater than the tensile strength of a melt-  
25          blown fiber and the birefringence number of a spun-bond fiber or filament is typically greater than the birefringence number of a meltblown fiber.

          If desired, the non-woven material **31** may comprise one or more plies of a laminate material, such as spunbonded / meltblown / spunbonded (SMS) laminate  
30          or a spunbond / meltblown (SM) laminate. An SMS laminate may be made by sequentially depositing onto a moving forming belt first a spunbond web layer, then a meltblown web layer and last another spunbond layer and then bonding the laminate in a manner described below. Alternatively, the web layers may be made

individually, collected in rolls, and combined in a separate bonding step. SMS materials are described in U.S. Patent No. 4,041,203, issued on August 9, 1977 to Brock et al.; U.S. Patent No. 5,464,688, issued on November 7, 1995 to Timmons, et al.; U.S. Patent No. 4,374,888, issued on February 22, 1983 to Bornslaeger;  
5 U.S. Patent No. 5,169,706, issued on December 8, 1992 to Collier, et al.; and, U.S. Patent No. 4,766,029, issued on August 23, 1988 to Brock et al., all of which are herein incorporated by reference to the extent that they are non-contradictory herewith. For some non-woven tissue making fabrics **30** of the present invention, the laminates should be made having higher melting point polymers than those of  
10 conventional SMS materials, such as polyphenylsulfide or other high-temperature polymers.

In an effort to produce non-woven webs for use as non-woven materials **31** having desirable combinations of physical properties, multi-component or bi-  
15 component non-woven webs have been developed. Methods for making bi-component non-woven webs are well-known and are disclosed in patents such as Reissue Number 30,955 of U.S. Patent No. 4,068,036, issued on January 10, 1978 to Stanistreet; U.S. Patent No. 3,423,266, issued on January 21, 1969 to Davies et al.; and, U.S. Patent No. 3,595,731, issued on July 27, 1971 to Davies et al. A  
20 bi-component non-woven web may be made from polymeric fibers or filaments including first and second polymeric components which remain distinct. As used herein, filaments mean continuous strands of material and fibers mean cut or discontinuous strands having a definite length. The first and second components of multi-component filaments are arranged in substantially distinct zones across  
25 the cross-section of the filaments and extend continuously along the length of the filaments. Typically, one component exhibits different properties than the other so that the filaments exhibit properties of the two components. For example, one component may be polypropylene which is relatively strong and the other component maybe polyethylene which is relatively soft. The end result is a strong  
30 yet soft non-woven web. Bi-component structures may be selected depending on the needs of the layer of non-woven material **31** of the non-woven tissue making fabric **31** under consideration. Concentric sheath-core cross-section filaments may be useful for good strength properties, for example, while asymmetrical sheath-



core cross-section filaments or side-by-side cross-section filaments can result in high-bulk non-wovens.

U.S. Patent No. 3,423,266, issued on January 21, 1969 to Davies et al. and  
5 U.S. Patent No. 3,595,731, issued on July 27, 1971 to Davies et al. disclose methods for melt spinning bi-component filaments to form non-woven polymeric webs suitable for use as non-woven material **31**. The non-woven webs may be formed by cutting the meltspun filaments into staple fibers and then forming a bonded carded web or by laying the continuous bi-component filaments onto a  
10 forming surface and thereafter bonding the non-woven web. To increase the bulk of the bi-component non-woven webs, the bi-component fibers or filaments are often crimped. As disclosed in U.S. Patent No. 3,595,731 and U.S. Patent No. 3,423,266 (discussed above), the bi-component filaments may be mechanically crimped and the resultant fibers formed into a non-woven web or, if the appropriate  
15 polymers are used, a latent helical crimp, produced in bi-component fibers or filaments may be activated by heat treatment of the formed non-woven web. The heat treatment is used to activate the helical crimp in the fibers or filaments after the fibers or filaments have been formed into a non-woven web.

20 While many applications of the present invention may include polymers capable of withstanding elevated temperatures, lower temperature applications such as wet pressing fabrics and in some cases, forming fabrics may also be contemplated. For such applications, polymers with lower melting points or glass transition temperatures ( $T_G$ ) can be useful. And in some applications, improved  
25 processing of the non-woven material is possible at lower  $T_G$ . For example, the non-woven material may comprise a polymer or polymer blend having a  $T_G$  of about 60 °C. or less, specifically about 50 °C. or less, more specifically about 45 °C. or less, and most specifically about 40 °C. or less.

30 The non-woven tissue making fabric **30** may be further provided with wear-resistance elements (not shown) on the tissue machine surface (opposing the tissue contacting surface) that may be extruded polymeric beads, threads, bumps, berms, strips, and the like. Raised elements may also be added to improve

traction with roll handling equipment. Similar elements may also be added to the tissue contacting surface and/or interior of the non-woven tissue making fabric **30**.

**Figure 3** shows a schematic view of a method for manufacturing a non-woven tissue making fabric **30**. One embodiment of the method uses an apparatus **40** comprising a first roll **42** and a second roll **44**, which are parallel to each other and which may be rotated in the direction indicated by the arrows. A carrier fabric **41** loops around the two rolls **42** and **44**, providing a moving surface onto which a fabric strip **34** of the non-woven material **31** may be disposed as it is unwound from a stock roll **46**. The fabric strip **34** travels with the carrier fabric **41** to pass around the first roll **42** and the second roll **44** in a continuous spiral.

The carrier fabric **41** may be a textured, woven fabric such as a sculpted through-drying fabric disclosed in U.S. Patent No. 6,017,417, issued on January 25, 2000 to Wendt et al., previously incorporated by reference, or other fabrics or textured belts known in the art. In other embodiments of the present invention, a flat woven or non-woven carrier fabric **41** may be incorporated into tissue making fabric **30**.

The process depicted in **Figure 3** is at an early stage in the formation of the non-woven tissue making fabric **30**. The initial placement of the fabric strip **34** on the carrier fabric **41** forms the leading edge **58** of the spirally wound fabric strip **34** in the non-woven tissue making fabric **30**. The non-woven material **31** on the carrier fabric **41** immediately behind the leading edge **58** is part of a first fabric turn **60a** on the carrier fabric **41**. The fabric strip **34**, having made a complete revolution around the carrier fabric **41**, is shown in the beginnings of a second fabric turn **60b** which slightly overlaps the first fabric turn **60a**. The overlapping region, once bonded (binding means are not shown), forms a seam **48**.

As the fabric strip **34** is disposed on the carrier fabric **41**, the fabric strip **34** may be held in place by the presence of a light adhesive, pneumatic pressure (e.g., spaced apart vacuum boxes), electrostatic charge, mechanical restraint, elevated temperature, or other means.

According to embodiments wherein the carrier fabric **41** may be porous and textured, the texture may be applied to the non-woven material **31** through a combination of elevated temperature and/or mechanical force to mold the non-woven material **31** against the carrier fabric **41**. According to embodiments of the present invention wherein the carrier fabric **41** may be textured, the texture may be applied to the non-woven material **31** through a combination of elevated temperature and mechanical force to mold the non-woven material **31** against the carrier fabric **41**. The mechanical force may be a nip, such as a soft thick nip for a textured carrier fabric, or web tension around a curved surface. Elevated temperature may be provided by passing hot air through the wet tissue web **15** and the carrier fabric. Impingement and/or radiant heating may be used, even if the web of material **31** is impermeable.

In alternative embodiments of the present invention, the carrier fabric **41** may be replaced with a draw between the first roll **42** and the stock roll **46**. The fabric strip **34** may then be bonded to the first fabric turn **60a**. The binding step may occur on the first roll **42** to form the non-woven tissue making fabric **30**. Tension may be applied between the first roll **42** and the stock roll **46**, thereby providing a mechanical force to hold the fabric strip **34** during binding. The first roll **42** may be replaced with a vacuum transfer roll or other device that may increase the holding force during binding of the fabric strip **34** to the first fabric turn **60a**.

As the fabric strip **34** is held in contact to the first fabric turn **60a** on the first roll **42**, the fabric strip **34** may be held in place by the presence of a light adhesive, pneumatic pressure (e.g., spaced apart vacuum boxes), electrostatic charge, mechanical restraint, elevated temperature, or other means.

The first roll **42** and the second roll **44** are separated by a distance  $D$ , such that the resulting endless non-woven tissue making fabric **30** is of the desired length, being measured in the machine direction **52** about the endless-loop of the non-woven tissue making fabric **30**. (Also shown are the cross-direction **53** and the z-direction **55**.) The width of the non-woven fabric strip **34** of the non-woven

material **31** may be varied to reflect desired seam strength, ease of handling during manufacture, and trim waste values.

5 The non-woven fabric strip **34** of the non-woven material **31** may have a width ranging between about 1 inch and about 600 inches; between about 1 inch and about 300 inches; between about 2 inches and about 100 inches; between about 2 inches and about 50 inches; and, between about 3 inches and about 20 inches, or may have a width of about 12 inches or less, or a width of about 6 inches or less. In some embodiments of the present invention, the non-woven  
10 fabric strip **34** of the non-woven material **31** may have a width ranging between about 30 to about 100 inches. The fabric strip **34** of the non-woven material **31** has a first edge **36** and an opposing second edge **38**. The fabric strip **34** is spirally wound onto the first and second rolls **42** and **44**, respectively, in a plurality of revolutions of the stock roll **46**. The resulting non-woven tissue making fabric **30**  
15 may have a continuous spiral seam **48** that passes around the endless loop comprising the non-woven tissue making fabric **30** a plurality of times. As will be seen, other seam configurations are possible, including multiple discrete seams in the machine direction, cross-direction, or other direction.

20 As the fabric strip **34** is wound around the carrier fabric **41**, overlapping sections (turns, in this case) of the fabric strip **34** may be lightly tacked together with adhesive or other means until subsequent bonding and optional molding steps occur. In one embodiment, the tacked-together embryonic non-woven tissue making fabric **30** is subjected to thermal bonding with heated air, infrared radiation,  
25 a heated nip, or other means, followed by optional molding. In another embodiment, molding and bonding take place simultaneously. For example, the embryonic non-woven tissue making fabric **30** may be passed through a heated nip between opposing intermeshing textured rolls to thermally bond and mold the embryonic non-woven tissue making fabric **30** into a macroscopic three-  
30 dimensional texture suitable for through-air drying or other operations. Bonding can be done after the embryonic non-woven tissue making fabric **30** is removed from the carrier fabric **41**, or while it remains thereon.

Successive turns of the fabric strip **34** of the non-woven material **31** are disposed relative to one another in an overlapping manner as illustrated hereafter, for example, in **Figure 8a**, and are bonded to one another along a spirally continuous seam **48** thereby producing a non-woven tissue making fabric **30**. It is understood that the bonding of the spiral seam **48** (or any other seam of the present invention) may be accomplished by any known method in the art. Such methods may include refastenable and non-refastenable methods. (See the discussion above). When the desired number of turns of the fabric strip **34** of the non-woven material **31** has been made to produce the desired width (W) of the non-woven tissue making fabric **30** as measured in the cross-machine direction of the nonwoven tissue making fabric **30**, the spiral winding is concluded. The non-woven tissue making fabric **30** may have a W ranging between about 12 inches and about 500 inches; between about 50 inches and about 300 inches; between about 100 inches and about 250 inches; between about 120 inches and about 250 inches; and, about 200 inches.

According to one embodiment of the present invention, the fabric strip **34** of the non-woven material **31** is spirally wound in a plurality of contiguous turns such that the first edge **36** of the fabric strip **34** of the non-woven material **31** in one turn extends beyond the second edge **38** of the fabric strip **34** of the non-woven material **31** of an adjacent (the previous) turn of the fabric strip **34** of the non-woven material **31**. The over-lapping of the first edge **36** of the fabric strip **34** of the non-woven material **31** over the second edge **38** of the fabric strip **34** of the non-woven material **31** on a previous turn creates a spirally continuous seam **48** and an endless non-woven tissue making fabric **30**.

Upon completion of the spiral winding, the lateral edges of the non-woven tissue making fabric **30** may not be parallel to the machine direction **52** of the non-woven tissue making fabric **30**. Such lateral edges will need to be trimmed to produce the first and second side edges **54** and **56** of the non-woven tissue making fabric **30** thereby establishing the non-woven tissue making fabric **30** having the desired width. The non-woven tissue making fabric **30** includes a machine direction **52**, and a cross-machine direction **53**.

In one embodiment, the strength of the non-woven tissue making fabric **30** or fabric seams may be increased by adding a scrim layer (not shown), such as a scrim layer sandwiched between two or more plies of the non-woven material **31** or the non-woven tissue making fabric **30**. The scrim layer may be a rectangular grid, a hexagonal network, or any other network providing good tensile strength in at least one in-plane direction. The scrim layer may be formed of one or more materials such as a synthetic polymer, fiberglass, metal wires, a perforated film or foil, and the like. Examples of scrim layers as a reinforcement for a nonwoven fabric or film are disclosed in the following patents: U.S. Patent No. 4,363,684, issued on December 14, 1982 to Hay; U.S. Patent No. 4,731,276, issued on March 15, 1988 to Manning et al.; U.S. Patent No. 3,597,299, to Thomas et al.; and, U.S. Patent No. 5,139,841, issued on August 18, 1992 to Makoui et al., all of which are herein incorporated by reference to the extent that they are non-contradictory herewith. The scrim could be a highly open rectilinear grid of a polymeric material. Further examples of scrim suitable for reinforcing the non-woven tissue making fabric **30** of the present invention are disclosed in U.S. Patent No. 4,522,863, issued on June 11, 1985 to Keck et al.; U.S. Patent No. 4,737,393, issued on April 12, 1988 to Linkous; and, U.S. Patent No. 5,038,775, issued on August 13, 1991 to Maruscak et al., all of which are herein incorporated by reference to the extent that they are non-contradictory herewith. Production methods may also comprise the use of rotating nozzles to produce rectilinear threads of polymer. It is understood that scrim may also be used to add texture to the non-woven tissue making fabric **30**. Scrim may also be added to the non-woven tissue making fabric **30** to provide or enhance wear resistance of the non-woven tissue making fabric **30**. Scrim may be added to the tissue contacting surface **51**, the tissue machine contacting surface **50**, and/or the interior of the non-woven tissue making fabric **30**.

Seams **48** may be reinforced with adhesive, sewn thread, ultrasonic welding, extra layers of material, an added scrim layer, and any other means known in the art. The nonwoven tissue making fabric **30** of the present invention may have a machine direction seam strength of about 100 pli (pounds per linear inch) or more,

meaning that an in-plane machine direction tensile force of at least about 200 pounds per linear inch can be applied to a seam **48** (or to any portion of the non-woven tissue making fabric **30**, if there is no seam **48** in the machine direction) without causing failure. More specifically, the non-woven tissue making fabric **30** may have a seam strength and/or belt strength of about 150 pli or greater, more specifically still about 200 pli or greater, more specifically still about 250 pli or greater, and most specifically about 350 pli or greater. Typical fabric tensions encountered by the non-woven tissue making fabric **30** during operation may be from about 2 pli to about 90 pli, specifically from about 5 pli to about 60 pli, more specifically from about 5 pli to about 25 pli, and most specifically from about 5 pli to about 15 pli, though operation outside these limits is not necessarily outside the scope of the present invention.

While high seam strengths are sometimes desirable, they are not necessary for all applications. Further, a spirally continuous seam **48** or other seams **48** of the present invention generally need not withstand the full machine direction tension normally present during use of the non-woven tissue making fabric **30**, because the seams **48** in many embodiments of the present invention are not aligned with the cross-direction, as is often the case in conventional tissue machine fabrics, but rather at an angle to the cross-direction and may even be substantially aligned with the machine direction. Thus, the requirements for seam strength may be substantially mitigated due to the favorable geometry achieved in many embodiments of the non-woven tissue making fabric **30** of the present invention. In many such embodiments, good results may be obtained with seams **48** constructed to withstand forces normal to the seam **48** from about 2 to about 30 pli, more specifically from about 8 to about 25 pli, and most specifically from about 10 to about 20 pli.

Any known method may be used to control the position of a fabric strip **34** as it is laid down to form a non-woven tissue making fabric **30** according to the present invention. Illustrative tools for this purpose are disclosed in U.S. Patent No. 4,962,576, issued on October 16, 1990 to Minichshofer et al., herein incorporated by reference to the extent that it is non-contradictory herewith, which treats a

system for joining a nonwoven fabric to a woven carrier. Such a system may be adapted such that a nonwoven web is joined to a nonwoven carrier for the purposes of the present invention. Minichshofer et al. employs a web guide in cooperative association with a needling system. Many other systems may be used  
5 in the present invention, such as image analysis systems or other optical systems coupled with standard web guide devices to track and control the location of the fabric strips **34**, coupled with mechanical actuators to ensure the fabric strip **34** is placed correctly as the non-woven tissue making fabric **30** is formed. In another embodiment of the present invention, the first roll **42** and the second roll **44** are  
10 substantially parallel. Tension may be applied on the fabric strip **34** between the first and second rolls **42** and **44**. The first and second rolls **42** and **44** may rotate at the same speed. With the application of a worm gear coupled to the rolls **42** and/or **44**, the unwinding of the fabric strip **34** from the stock roll **46** at a set angle to the machine direction **52** may be affected.

15

The non-woven tissue making fabric **30** of the present invention or the non-woven materials **31** used therefor may be provided with texture by any known method. For example, portions of an upper ply, layer, or stratum (in some cases, forming the tissue contacting surface **51** or adjacent the tissue contacting surface  
20 **51** of the non-woven tissue making fabric **30**) of the non-woven material **31** (or the non-woven tissue making fabric **30**) may be selectively removed to impart texture, using any known removal method such as cutting, stamping, laser cutting, laser ablation, drilling, and the like. Portions of the tissue contacting surface **51** of the non-woven tissue making fabric **30** may also be selectively densified to create  
25 texture using any known method such as embossing, stamping, ultrasonic welding, thermal welding, hot pin aperturing, thermal molding, and the like. Further, additional material can be selectively added to regions of an otherwise planar non-woven tissue making fabric **30** to impart elevated regions for an overall three-dimensional topography. Such added material may comprise non-woven material  
30 **31** such as that used for one or more plies of the non-woven tissue making fabric **30**, or other permeable material such as a polymeric foam, or even regions of substantially impermeable material. The added material may be attached by adhesives, thermal welding, ultrasonic welding, needling, or any other method



known in the art. In a related embodiment, the added material may be applied to the non-woven tissue making fabric **30** by extruding the material on to the surface or by a printing technique, such as a hot melt or non-pressure-sensitive adhesive applied via ink jet printing, flexographic printing, and the like.

5

In one embodiment, an array of spaced apart pins is controlled by computer or other means such that selected pins strike the non-woven tissue making fabric **30** to densify it or aperture the non-woven tissue making fabric **30** in a pattern. The pins may apply digitally controlled patterns to the non-woven tissue making fabric **30** in a manner similar to the generation of printed patterns using dot matrix printers, with the dots of the dot matrix printer being analogous to the pins in the pin array.

Thermoplastic non-woven material **31** may be provided with texture by molding methods, in which the non-woven material **31** (or the non-woven tissue making fabric **30**) is elevated in temperature as the non-woven material **31** is constrained to take a three-dimensional shape by methods such as pressing the non-woven material **31** between molding plates, applying an air pressure differential to the non-woven material **31** as the non-woven material **31** rests on a three-dimensional surface such as the textured through-drying fabrics disclosed in U.S. Patent No. 6,017,417, issued on January 25, 2000 to Wendt et al., previously incorporated by reference; the textured fabrics disclosed in commonly owned U.S. Patent Application Serial No. 09/705684 by Lindsay et al.; the fabrics disclosed in U.S. Patent No. 5,167,771, issued on December 1, 1992 to Sayers et al.; or, the fabrics disclosed in U.S. Patent No. 4,740,409, issued on April 26, 1988 to Lefkowitz, all of which are herein incorporated by reference to the extent that they are non-contradictory herewith.

In addition, texture may be provided to the thermoplastic non-woven material **31** by placing the non-woven material **31** (or the non-woven tissue making fabric **30**) under tension, such as wrapping the non-woven material **31** (or the non-woven tissue making fabric **30**) about a roll (such as a first roll **42**, a second roll **44**, or a stock roll **46**). Heat may or may not be used in addition to the tension.

The three-dimensional texture of the non-woven tissue making fabric **30** may comprise a repeating pattern, such as any pattern known in woven papermaking fabrics, photocured fabrics such as the previously discussed imprinting fabrics, or other fabrics, with exemplary repeating patterns including series of raised and depressed elements defining a repeating unit cell, the unit cell having a width of about any of the following values or greater: 3 millimeters (mm), 1 centimeter (cm), 5 cm, 10 cm, 20 cm, or substantially the cross-machine direction width of the non-woven tissue making fabric **30**. The width of the unit cell may also be adapted to the finished width of the non-woven tissue making fabric **30**. The length of the unit cell may be about any of the following values or greater: 3 millimeters (mm), 1 centimeter (cm), 5 cm, 10 cm, 20 cm, or about a percentage value of the machine direction length of the non-woven tissue making fabric **30** selected from 1%, 5%, 10%, 20%, 30%, 50%, or 100%. The length of the unit cell may also be adapted to the finished length of the non-woven tissue making fabric **30**. It is understood that wherein the length of the unit cell is greater than the length of the non-woven tissue making fabric **30**, and/or the tissue making fabric length is not an integer multiple of the unit cell length, there may be a discontinuity in the repeating pattern. In one embodiment, the unit cell is as great as or greater than either the machine direction length or the cross-direction width or both of the non-woven tissue making fabric **30**.

**Figure 4** depicts a molding section **59** in a process for making a non-woven tissue making fabric **30**, which is one embodiment for joining two superposed layers **39a** and **39b** of non-woven material **31** together to form the non-woven tissue making fabric **30**, and for imparting texture to the non-woven tissue making fabric **30**. Texture may be imparted by molding the non-woven tissue making fabric **30** (most particularly the layer **39b** of the non-woven material **31** adjacent the carrier fabric **41**) against the underlying carrier fabric **41**, which may be a textured fabric with significant three-dimensional topography. An air knife **62** above the non-woven tissue making fabric **30** delivers heated air at an elevated pressure (stagnation pressure greater than atmospheric pressure) as the layers **39a** and **39b** of the non-woven material **31** and carrier fabric **41** travel in the machine direction **52**. The heated air is pulled through the non-woven tissue

making fabric **30** and the carrier fabric **41** with the optional assistance of a vacuum box **64** beneath the carrier fabric **41**. The air knife **62** may deliver air heated to a sufficient temperature to soften thermoplastic material in one or both of the layers **39a** and **39b** of the non-woven material **31**, permitting the layers **39a** and **39b** (most particularly the layer **39b**) to conform better to the carrier fabric **41** and to assume its shape to a degree.

The non-woven tissue making fabric **30** has two surfaces, a "tissue machine contacting surface" **50** (the surface generally intended for contacting a tissue making machine during the tissue making process), and a "tissue contacting surface" **51** (the surface generally intended for contacting the tissue web during the tissue making process). In the embodiment shown in **Figure 4**, the tissue contacting surface **51** of the non-woven tissue making fabric **30** is substantially more textured (more highly molded) than the tissue machine contacting surface **50**, though in other embodiments, both the tissue contacting and tissue machine contacting surfaces **50** and **51**, respectively, could have a similar degree of texture, or the tissue machine contacting surface **50** could be more highly textured. It is understood that the tissue machine contacting surface **50** may comprise the same or different pattern or texture than the tissue contacting surface **51** of the non-woven tissue making fabric **30**.

The presence of sheath-core binder materials in non-woven materials **31** useful in the non-woven tissue making fabrics **30** may be helpful in molding, for the fusion of the sheath at elevated temperature followed by cooling of the non-woven material **31** results in fusion of the thermoplastic material of the sheath to better lock the molded structure in place. Likewise, a first portion of fibers in the non-woven material **31** may be thermoplastic with a lower melting point than a second portion of fibers in the non-woven material **31**, such that the first portion of fibers may more easily melt and fuse the second portion of fibers together in the molded shape.

The molding section **59** may be installed in the apparatus **40** of **Figure 3**, and may comprise an air knife of approximately the same width as the fabric strip

**34**, adapted to move in the cross-direction **53** to bond successive turns of the fabric strip **34** of non-woven material **31** to the underlying fabric strip **34** of the non-woven material **31** from the previous turn. The air knife may be of a width less than about the width of the fabric strip **34**, a width about the same as the width of the fabric strip **34**, or greater than the width of the fabric strip **34**. The air knife may be of a width less than about the width of the finished non-woven tissue making fabric **30**, a width about the same as the width of the finished non-woven tissue making fabric **30**, or greater than the width of the finished non-woven tissue making fabric **30**. In some embodiments of the present invention, the width of the fabric strip **34** may be the width of the finished non-woven tissue making fabric **30** or the width of the apparatus on which the non-woven tissue making fabric **30** is manufactured on.

Other principles for molding a web against a molding substrate are disclosed by Chen et al. in commonly owned application U.S. Patent Application Serial No. 09/680719, filed on October 6, 2000 by Chen et al., herein incorporated by reference to the extent that it is non-contradictory herewith.

In another embodiment, the non-woven tissue making fabric **30** is not separated from the carrier fabric **41**, but remains in contact with and preferably is bonded to the carrier fabric **41**, such that the carrier fabric **41** becomes an integral part of the non-woven tissue making fabric **30**, serving, for example, as a strength layer, wear-resistant layer, and/or texture layer in one or both of the tissue contacting surface **51** and the tissue machine contacting surface **50** of the non-woven tissue making fabric **30**.

In another embodiment (not shown), the carrier fabric **41** may be used to receive nonwoven fibers as they are produced in a meltblown, spunbond, or other process, such that the non-woven material **31** is formed directly on a three-dimensional carrier fabric **41** to directly impart a three-dimensional structure to the non-woven material **31**.

**Figure 5** depicts another embodiment of a molding section in which a two-ply non-woven tissue making fabric **30** passes over a rotating molding device **92** provided with raised molding elements **94** on the surface. The molding elements **94** as depicted are porous, comprising a material such as sintered metal, sintered ceramic, ceramic foam, or a finely drilled metal or plastic, allowing heated air to pass from an air knife **62** or other source, through the non-woven tissue making fabric **30** and into the rotating molding device **92** and to a vacuum source **96**. Heated air from the air knife **62** allows thermoplastic material in at least one of the plies of non-woven material **31a** and **31b** to be thermally molded to conform at least in part to the surface of the rotating molding device **92**. The molding elements **94** may be any shape, such as sine waves, triangles (as shown), square waves, irregular shapes, or other shapes. The rotating molding device **92** may be constructed as a suction roll to allow a narrow zone of vacuum to be applied to a fixed region as the roll rotates. The surface of the non-woven tissue making fabric **30** becomes substantially textured after contact with the rotating molding device **92**, which may also be heated. The surface of the rotating device **92** may comprise discrete elements and/or may comprise a continuous shell. It is understood that the surface or shell of the rotating molding device **92** comprises a negative image of the desired shape or pattern of the tissue contacting surface **51** of the resulting non-woven tissue making fabric **30**. In addition, the negative image on the surface of the rotating molding device **92** of the desired shape or pattern for the tissue contacting surface **51** of the non-woven tissue making fabric **30** may be adapted to vary the depth or intensity of the pattern on the tissue contacting surface **51** of the non-woven tissue making fabric **30**. The pattern may be a continuous curvilinear, discrete elements, or a combination of both types.

It is understood that when a 2-ply non-woven tissue making fabric **30** is discussed herein, that such discussion may be applied to non-woven tissue making fabrics **30** comprising 2 or more plies. The non-woven tissue making fabric **30** may comprise about 1 ply or more. In other embodiments, the non-woven tissue making fabric **30** may comprise between about 1 ply and about 25 plies, more specifically between about 1 ply and about 10 plies.

**Figure 6** depicts yet another embodiment of a molding section in which a two-ply non-woven tissue making fabric **30** passes over a rotating molding device **92** provided with raised molding elements **94** on the surface, similar to that shown in **Figure 5**, but wherein the air is supplied from a pressurized source **98** connected to a rotating gas-pervious roll **100** through which the pressurized gas passes into a nip **102** between the rotating gas-pervious roll **100** and the counter-rotating molding device **92**. Both the rotating gas-pervious roll **100** and the counter-rotating molding device **92** may be constructed as a suction roll to allow a narrow zone of vacuum to be applied to a fixed region as the gas-pervious roll **100** rotates. In the nip **102**, heated air passes through the non-woven tissue making fabric **30** and mechanical pressure further conforms the non-woven tissue making fabric **30** to the shape of the rotating molding device **92** to improve the degree of texture imparted to the non-woven tissue making fabric **30**. A one-sided texture is shown, but both sides of the non-woven tissue making fabric **30** may become molded. Enhanced two-sided molding may be achieved by using a textured rotating gas-pervious roll **100** with a texture that may be essentially a mirror image of the texture of the rotating molding device **92** to permit intermeshing of the textured surfaces of the rotating molding device **92** and the gas-pervious roll **100** in the nip **102**. In an alternate embodiment, a gas pervious roll **100** may be fitted with a suitably textured surface to impart a texture to the tissue machine contacting surface **51** which is substantially independent of the texture on the tissue contacting surface **50** of the non-woven tissue making fabric **30**.

**Figure 7** depicts a top view of a portion of a non-woven tissue making fabric **30** according to the present invention. A plurality of fabric strips **34a - 34e**, are shown, substantially aligned with the machine direction **52** of the non-woven tissue making fabric **30**. Each of the fabric strips **34b - 34e** overlaps a portion of the adjacent fabric strips **34a - 34d**, respectively, defining regions of overlap that are bonded to form seams **48a - 48d**. Each fabric strip **34a - 34e** has a first edge **36a - 36e**, respectively, and a second edge **38a - 38e**, respectively. The non-woven tissue making fabric **30** itself has a first side edge **54** and a second side edge **56**. The seams **48a - 48d** may be spirally continuous, or may comprise a plurality of

substantially parallel, discrete seams **48** formed by joining a plurality of discrete fabric strips **34** (which may be discrete continuous loops).

The width "O" of the overlap region is a fraction of the fabric strip width "S".

5 The degree of overlap of the fabric strip **34** is the ratio O/S, which may vary from about 0 (abutting fabric strips **34** or sections of non-woven material **31**) to about 1 (multiple plies of non-woven material **31** that are coextensive, at least in one dimension), or any value in between. For example, the degree of overlap may range from about 0 to any integral multiple of about 0.02 less than or equal to

10 about 1.0 (e.g., from about 0 to about 0.64), or may range from any multiple of about 0.02 less than or equal to about 0.98 to a maximum value of about 1 (e.g., from about 0.64 to about 1), or may cover any subset of such ranges such as from about 0.06 to about 0.7, or from about 0.1 to about 0.5, or from about 0.1 to about 0.48. For example, the degree of overlap may be about 1 or less than about 1.

15 In another embodiment, the degree of overlap may be about 0.66. In yet another embodiment of the present invention, the degree of overlap may be about 0.90.

**Figures 8A** and **8B** depict alternate embodiments in which a fabric strip **34** is wound in a plurality of turns to form a non-woven tissue making fabric **30**, but

20 wherein the fabric strip **34** is aligned at an acute angle substantially away from the machine direction **52** of the non-woven tissue making fabric **30**. In the embodiment shown in **Figure 8A**, a fabric strip **34** having a width is folded back upon itself repeatedly in what may be termed a "flattened helix." The first and second side edges **54** and **56** of the non-woven tissue making fabric **30** coincide

25 with the folds of the fabric strip **34**. A first section of the fabric strip **34a** has a longitudinal axis at a first angle **86** relative to the machine direction **52** and reverses upon itself at a first fold **37a**, continuing in a second section of the fabric strip **34b** with its longitudinal axis at a second angle **88** relative to the machine direction **52**, which then reverses upon itself at a second fold **37b**, and so forth.

30 The first edge **36b** of the second section of the fabric strip **34b** resides beneath the first section of the fabric strip **34a**. The first edge **36c** of the third section of the fabric strip **34c** abuts the second edge **38a** of the first section of the fabric strip **34b**, and so forth. (In an alternate embodiment (not shown), the first edge **36c** of the

third section of the fabric strip **34c** overlaps the second edge **38a** of the first section of the fabric strip **34b**, and so forth.)

5 The flattened helix structure of the non-woven tissue making fabric **30** provides a ply having two layers throughout the non-woven tissue making fabric **30**. The abutting edges **36** and **38** of adjacent sections of the fabric strip **34** in a given layer define a spirally continuous seam **48** having a flattened helical form, with two sets of parallel regions at a first angle **86** and a second angle **88**, respectively. (Other embodiments lacking the flattened helical structure may have seams **48** that are substantially parallel throughout the non-woven tissue making fabric **30**, including seams **48** substantially aligned with or at an acute angle to the machine direction **52**, or may also have a plurality of seams **48** aligned with a plurality of angles.)

15 The overlapping layers of the non-woven tissue making fabric **30** formed from the fabric strips **34** may be bonded together throughout the non-woven tissue making fabric **30** or primarily along the seam **48**. Reinforcing layers may be added, as desired.

20 In general, a single fabric strip **34** may provide more than one parallel section **34a** and **34c**, as can occur when a fabric strip **34** is folded back upon itself as shown in **Figure 8A** or when a fabric strip **34** has a complex shape such as a zig-zags shape, as discussed hereafter in connection with **Figure 11**. If a fabric strip **34** has a simple linear shape (e.g., an elongated rectangle), then the fabric strips **34** and sections of the fabric strips **34** are synonymous, otherwise a section such as the first section of the fabric strip **34a** may be a subset of a fabric strip **34**.

30 **Figure 8B** depicts a non-woven tissue making fabric **30** similar to that of **Figure 8A** but with reinforcing strips **90a** and **90b** added along the first and second side edges **54** and **56** of the non-woven tissue making fabric **30**, between the two overlapping plies at the internal portion of the folds **37a** and **37b**, etc. The reinforcing strips **90a** and **90b** may be non-woven material, ropes, metal wires,



fiberglass-reinforced bands, a polymeric film, and the like, and may be joined by adhesive means, thermal bonding, ultrasonic bonding, or any other known means.

**Figure 9** depicts a non-woven tissue making fabric **30** comprising a plurality of discrete fabric strips **34** having a strip width "S". The fabric strips **34a - 34e** (the 5 exemplary fabric strips **34** are numbered) lie at an acute angle **86** to the machine direction **52** of the non-woven tissue making fabric **30**. Further, each fabric strip **34a - 34e** overlaps about 50% of the "S" width of each neighboring fabric strip **34a - 34e** (the degree of overlap in this example would be about 0.5), such that the non-woven tissue making fabric **30** has a basis weight equal to approximately twice the basis weight of an individual fabric strip **34a - 34e**.

The non-woven tissue making fabric **30** has a tissue machine contacting surface **50** and a tissue contacting surface **51**, which in the embodiment shown, may have substantially the same topography, unless the individual fabric strips **34** have a two-sided texture (wherein one side is more textured than the other side). The fabric strips **34** need not all be comprised of the same non-woven material **31**, but may be taken from a plurality of non-woven materials **31**. For example, the fabric strips **34** may alternate between a first and second non-woven material **31**. Additional material (not shown) may be added at the first and second side edges **54** and **56** to further reinforce the non-woven tissue making fabric **30**.

In other embodiments (not shown), the discrete fabric strips **34** may have a variety of widths, such as fabric strips **34** selected from two or more widths "S". In another embodiment (not shown), the width of the fabric strips **34** varies with position, such as where the fabric strips **34** have sinusoidal edges that periodically increase and decrease the width of the fabric strip **34**.

**Figure 10** shows a non-woven tissue making fabric **30** having a plurality of fabric strips **34** that are interwoven to form an interwoven non-woven tissue making fabric **30**. The piece of the non-woven tissue making fabric **30** shown has interwoven fabric strips **34** comprising a first group **35** of parallel strips **34a - 34e** aligned in a first direction **87** at an acute angle **88** with the machine direction **52**,

and a second group **35'** of parallel fabric strips **34a'** - **34e'** aligned in a second direction **85** at an acute angle **86** with the machine direction **52**, and interwoven such that any fabric strip **34** successively passes over and under other fabric strips **34** in the non-woven tissue making fabric **30**. While the interwoven arrangement of  
5 fabric strips **34** may provide an interlocking structure, the fabric strips **34** may be bonded together in regions where one fabric strip **34** is above or below another fabric strip **34**, or along the first and second edges **36** and **38** of adjoining parallel fabric strips **34**, or both, to increase the mechanical stability and durability of the non-woven tissue making fabric **30**.

10

**Figure 11** depicts another interlocking non-woven tissue making fabric **30** comprising interlocking fabric strips **34**, wherein at least one fabric strip **34** is a non-straight strip comprising at least two portions **45** and **45'** wherein the first portion **45** is aligned with a first direction **85** at an acute angle **86** with the machine  
15 direction **52**, and the second portion **45'** is aligned with a second direction **87** at an acute angle **88** with the machine direction **52**. Within a transition region **49**, the first portion **45** is joined with the second portion **45'**. The transition region **49** may be a simple elbow as depicted, or may be curved or any other suitable shape. The first and second portions **45** and **45'** need not be linear but may be sinusoidal or  
20 have other shapes while extending substantially in the first and second directions **85** and **87**, respectively. As depicted, three non-straight fabric strips **34a** - **34c** are shown, each with linear first and second portions **45** and **45'**. The non-straight fabric strips **34a** - **34c** are interwoven such that the fabric strips **34** successively pass over and under each other in the non-woven tissue making fabric **30**. While  
25 the interwoven arrangement of fabric strips **34** may provide an interlocking structure, the fabric strips **34** may further be bonded together in regions where one fabric strip **34** is above or below another fabric strip **34**, or along the first and second edges **36** and **38** of adjoining parallel portions **45** and **45'**, or both, to increase the mechanical stability and durability of the non-woven tissue making  
30 fabric **30**.

More complex weave patterns may be contemplated other than the simple ones shown in **Figures 10** and **11**.

**Figure 12**, which is a variation of the embodiment shown in **Figure 7**, depicts a portion of another embodiment of a non-woven tissue making fabric **30** according to the present invention, formed into an endless loop, in which discrete parallel fabric strips **34** of non-woven material **31** have first ends **80** and second ends **82** that are joined together to form a traverse fabric seam **84**, while the first and second edges **36** and **38** of the fabric strips **34** are joined (shown here as overlapping) to form a longitudinal seam **48**. Shown are five fabric strips **34a - 34e**, each with respective first ends **80a - 80e** and second ends **82a - 82e** that are brought together to form the fabric seam **84** comprising staggered portions of the fabric seam **84a - 84e**. The first and second ends **80a - 80e** and **82a - 82e**, respectively, maybe fastened in a longitudinally overlapping or abutting fashion (an abutting fashion is depicted) and bonded together by any means known in the art as discussed herein to form the fabric seam **84** as were discussed in the formation of the seam **48**. The fabric seam **84** may be in a straight line or may be in a staggered line, as shown, in the cross-machine direction.

The first and second ends **80** and **82** of the fabric strips **34** are shown to be straight cross-directional cuts, but this need not be the case in other embodiments. The first and second ends **80** and **82** may be cut at any angle or multiple angles to the cross direction **53** and may be nonlinear, such as cuts having dovetail, curvilinear, or triangular characteristics.

**Figure 13** depicts a cross-sectional profile of the non-woven tissue making fabric **30** taken along line 13 - 13 in **Figure 12**. Shown are the fabric strips **34a - 34e**, depicted with tapered thickness profiles such that the overlapping regions in the vicinity of the seams **48a - 48d** have a thickness not significantly greater than in non-overlapping regions, such that the overall non-woven tissue making fabric **30** has a relatively uniform thickness along most of the cross-sectional profile.

30

## Test Methods:

### “Overall Surface Depth”

5           A three-dimensional tissue making fabric or tissue web may have significant variation in surface elevation due to its structure. As used herein, this elevation difference is expressed as the “Overall Surface Depth.” The non-woven tissue making fabrics and tissue webs of the present invention may possess three-dimensionality and may have an Overall Surface Depth of about 0.1 millimeter  
10 (mm) or greater, more specifically about 0.3 mm or greater, still more specifically about 0.4 mm or greater, still more specifically about 0.5 mm or greater, and still more specifically from about 0.4 mm to about 0.8 mm.

          A suitable method for measurement of Overall Surface Depth is moiré  
15 interferometry, which permits accurate measurement without deformation of the surface. For reference to the materials of the present invention, surface topography should be measured using a computer-controlled white-light field-shifted moiré interferometer with about a 38 mm field of view. The principles of a useful implementation of such a system are described in Bieman et al. (L. Bieman,  
20 K. Harding, and A. Boehnlein, “Absolute Measurement Using Field-Shifted Moiré,” SPIE Optical Conference Proceedings, Vol. 1614, pp. 259-264, 1991). A suitable commercial instrument for moiré interferometry is the CADEYES® interferometer produced by Medar, Inc. (Farmington Hills, Michigan), constructed for a nominal 35-mm field of view, but with an actual 38-mm field-of-view (a field of view within  
25 the range of 37 to 39.5 mm is adequate). The CADEYES® system uses white light which is projected through a grid to project fine black lines onto the sample surface. The sample surface is viewed through a similar grid, creating moiré fringes that are viewed by a CCD camera. Suitable lenses and a stepper motor adjust the optical configuration for field shifting (a technique described below). A video processor  
30 sends captured fringe images to a PC computer for processing, allowing details of surface height to be back-calculated from the fringe patterns viewed by the video camera.

In the CADEYES moiré interferometry system, each pixel in the CCD video image is said to belong to a moiré fringe that is associated with a particular height range. The method of field-shifting, as described by Bieman et al. (L. Bieman, K. Harding, and A. Boehnlein, "Absolute Measurement Using Field-Shifted Moiré," SPIE Optical Conference Proceedings, Vol. 1614, pp. 259-264, 1991) and as  
5 originally patented by Boehnlein (U.S. Patent No. 5,069,548, issued on December 3, 1991, the disclosure of which is herein incorporated by reference to the extent that it is non-contradictory herewith), is used to identify the fringe number for each point in the video image (indicating which fringe a point belongs to). The fringe  
10 number is needed to determine the absolute height at the measurement point relative to a reference plane. A field-shifting technique (sometimes termed phase-shifting in the art) is also used for sub-fringe analysis (accurate determination of the height of the measurement point within the height range occupied by its fringe). These field-shifting methods coupled with a camera-based interferometry  
15 approach allows accurate and rapid absolute height measurement, permitting measurement to be made in spite of possible height discontinuities in the surface. The technique allows absolute height of each of the roughly 250,000 discrete points (pixels) on the sample surface to be obtained, if suitable optics, video hardware, data acquisition equipment, and software are used that incorporates the  
20 principles of moiré interferometry with field-shifting. Each point measured has a resolution of approximately 1.5 microns in its height measurement.

The computerized interferometer system is used to acquire topographical data and then to generate a grayscale image of the topographical data, said image  
25 to be hereinafter called "the height map." The height map is displayed on a computer monitor, typically in 256 shades of gray and is quantitatively based on the topographical data obtained for the sample being measured. The resulting height map for the 38-mm square measurement area should contain approximately 250,000 data points corresponding to approximately 500 pixels in both the  
30 horizontal and vertical directions of the displayed height map. The pixel dimensions of the height map are based on a 512 x 512 CCD camera which provides images of moiré patterns on the sample which can be analyzed by computer software. Each pixel in the height map represents a height

measurement at the corresponding x- and y-location on the sample. In the recommended system, each pixel has a width of approximately 70 microns, i.e. represents a region on the sample surface about 70 microns long in both orthogonal in-plane directions). This level of resolution prevents single fibers projecting above the surface from having a significant effect on the surface height measurement. The z-direction height measurement should have a nominal accuracy of less than 2 microns and a z-direction range of at least 1.5 mm.

The moiré interferometer system, once installed and factory calibrated to provide the accuracy and z-direction range stated above, can provide accurate topographical data for materials such as paper towels. (The accuracy of factory calibration may be confirmed by performing measurements on surfaces with known dimensions.) Tests are performed in a room under Tappi conditions (73°F, 50% relative humidity). The sample must be placed flat on a surface lying aligned or nearly aligned with the measurement plane of the instrument and should be at such a height that both the lowest and highest regions of interest are within the measurement region of the instrument.

Once properly placed, data acquisition is initiated using CADEYES® PC software and a height map of 250,000 data points is acquired and displayed, typically within 30 seconds from the time data acquisition was initiated. (Using the CADEYES® system, the "contrast threshold level" for noise rejection is set to 1, providing some noise rejection without excessive rejection of data points.) Data reduction and display are achieved using CADEYES® software for PCs, which incorporates a customizable interface based on Microsoft Visual Basic Professional for Windows (version 3.0), running under Windows 3.1. The Visual Basic interface allows users to add custom analysis tools.

The height map of the topographical data can then be used by those skilled in the art to measure the typical peak to valley depth of a surface. A simple method of doing this is to extract two-dimensional height profiles from lines drawn on the topographical height map which pass through the highest and lowest areas of unit cells when there are repeating structures. These height profiles may then

be analyzed for the peak to valley distance, if the profiles are taken from a sheet or portion of the sheet that was lying relatively flat when measured. To eliminate the effect of occasional optical noise and possible outliers, the highest 10% and the lowest 10% of the profile should be excluded, and the height range of the remaining points is taken as the surface depth. Technically, the procedure requires calculating the variable which we term "P10," defined at the height difference between the 10% and 90% material lines, with the concept of material lines being well known in the art, as explained by L. Mummery, in *Surface Texture Analysis: The Handbook*, Hommelwerke GmbH, Mühlhausen, Germany, 1990. In this approach, the surface is viewed as a transition from air to material. For a given profile, taken from a flat-lying sheet, the greatest height at which the surface begins - the height of the highest peak - is the elevation of the "0% reference line" or the "0% material line," meaning that 0% of the length of the horizontal line at that height is occupied by material. Along the horizontal line passing through the lowest point of the profile, 100% of the line is occupied by material, making that line the "100% material line." In between the 0% and 100% material lines (between the maximum and minimum points of the profile), the fraction of horizontal line length occupied by material will increase monotonically as the line elevation is decreased. The material ratio curve gives the relationship between material fraction along a horizontal line passing through the profile and the height of the line. The material ratio curve is also the cumulative height distribution of a profile. (A more accurate term might be "material fraction curve.")

Once the material ratio curve is established, the curve is used to define a characteristic peak height of the profile. The P10 "typical peak-to-valley height" parameter is defined as the difference between the heights of the 10% material line and the 90% material line. One advantage of this parameter is that outliers or unusual excursions from the typical profile structure have little impact on the P10 height. The units of P10 are mm. The Overall Surface Depth of a material is reported as the P10 surface depth value for profile lines encompassing the height extremes of the typical unit cell of that surface.

Overall Surface Depth measurements in tissue should exclude large-scale structures such as pleats or folds which do not reflect the three-dimensional nature of the original basesheet itself. It is recognized that sheet topography may be reduced by calendering and other operations which affect the entire basesheet.

- 5 Overall Surface Depth measurement can be appropriately performed on a calendered basesheet.

Overall Surface Depth may be measured across sections of a fabric or paper web that are free of apertures, such that the profiles being considered pass  
10 exclusively over solid matter along the upper surface of the fabric or paper web.

### Examples:

#### 15 Example 1

In order to further illustrate the non-woven tissue making fabrics of the present invention, a laminated two-layer non-woven tissue making fabric was produced with a three-dimensional topography. The nonwoven base fabric  
20 comprised a spunbond web made from bi-component fibers with a concentric sheath-core structure. The sheath material comprised Crystar® 5029 Polyethylene Terephthalate (PET) polyester resin (The DuPont Company, Old Hickory, TN, USA). The core material comprised HiPERTUF® 92004 Polyethylene Naphthalate (PEN) polyester resin (M&G Polymers USA LLC, Houston, TX, USA).  
25 The sheath to core ratio was about 1:1 by weight. A bicomponent spunbond pilot line shown was used with a forming head having 88 holes per inch of face width, the holes having a diameter of 1.35mm holes. The polymer was pre-dried overnight in polymer dryers at about 320 °F, then extruded at a pack temperature of about 600°F at a pack pressure of about 980 psig for the core and about 770  
30 psig for the sheath, with a polymer flow rate of about 4 grams per hold per minute. The spin line length was about 50 inches. The quench air was provided at about 4.5 psig and a temperature of about 155 °F. The fiber draw unit operated at ambient temperature and a pressure of about 4 psig. The forming height (height



above the forming wire) was about 12.5 inches. The forming wire speed was about 65 fpm. Bonding was achieved with a hot air knife operating at pressure of about 2.5 psig and a temperature of about 300 °F at about 2 inches above the forming wire.

5

The resulting non-woven fabric had a fiber diameter of about 33 microns, a basis weight of about 100 grams per square meter (gsm), and air permeability of about 630 cubic feet per minute (CFM), and a maximum extensional stiffness of about 96 pli.

10

For molding of the nonwoven fabric into a three-dimensional fabric, two porous, three-dimensional metal plates were prepared from 2-mm thick aluminum discs 139 mm in diameter. First and second three-dimensional plates were prepared from two aluminum disc by machine-controlled drilling to selectively remove material as specified by a CAD drawing. A sinusoidal pattern was created for plates. In the first plate, the channels were specified to be about 0.035 inches (0.889 mm) deep with six channels per inch in the cross-direction. A photograph of the resulting molding plate is shown in **Figure 14**, showing the sinusoidal channels (depressed regions), with spaced apart holes providing passageways for gas flow. The holes are 0.030-inch diameter holes spaced at 12 per inch. The machined pattern and the holes were restricted to a circular region about 98 mm in diameter centered in a slightly larger circular plate about 100 mm in diameter. A second metal plate was also machined with a similar geometry but with 0.015-inch (0.38 mm) deep channels specified, spaced at 14 per inch. The photograph in **Figure 14** has dimensions of about 33 mm by about 44 mm.

15

20

25

30

**Figure 15** is a screen shot from software used with the CADEYES moiré interferometry tool showing height map of a portion of the first metal plate, taken with the 38-mm field of view CADEYES system. The higher regions appear lighter in color than the lower regions. The holes to permit air flow appear as spots of optical noise in the height map. A profile is displayed on the right hand side of the figure which corresponds to the height measurements along a line (not shown) selected in the vertical direction (top to bottom) of the height map; the line did not

pass through any of the regions corresponding to holes on the plate. The peak-to-valley height from the CADEYES measurement is about 0.84 mm, slightly less than the specified value.

5           **Figure 16** is another screen shot showing a topographical height map of a portion of the second three-dimensional plate also showing a profile line extracted from the a line along the height map (indicated on the height map as a light line terminated with circles) the topography of the channels. Optical noise occurs in several regions, not just over holes, possibly due to the shiny nature of the metal  
10 surface that posed difficulties for surface topography measurements in some regions.

One or more plies of the non-woven web cut into a disc with a diameter of 140 mm could be molded against the three-dimensional plate by holding the disc  
15 against the three-dimensional plate with an opposing flat backing plate, the backing plate having holes drilled with the same size and spacing as in the three-dimensional plate. Metal rings with an outer diameter of 139 mm and an inner diameter of about 101 mm and joined with adjustable screws formed a holder for the three-dimensional plate, a non-woven disc, and the flat backing plate. Heated  
20 air from a hot air gun was applied through a tube about 100 mm in diameter with an air velocity of about 1 m/s. The tube terminated with the flat backing plate held in place by the assembly of rings. Hot air passed through the backing plate, into the non-woven web, and then out through the holes of the three-dimensional plate. Inlet air temperature was controlled by adjusting the power setting on the heated  
25 air gun, with air temperature being measured after the air gun and prior to the backing plate by a thermocouple. The inlet air temperature was initially measured at 450°F, then was gradually increased over a period of 25 minutes to a peak temperature of 525°F, and the peak temperature was maintained for 10 minutes. Another thermocouple measured the air temperature after passing through the  
30 metal plates and the non-woven laminated. By the time that the inlet air temperature has reached about 525°F the outlet air temperature has reached between about 200°F and about 250°F. However, after ten minutes, the outlet air temperature had climbed gradually to about 275°F. The hot air gun was then

turned off and room-temperature air was passed through the system to cool off the plates and the non-woven laminate.

Two plies of the non-woven material were superimposed and heated as described above while being pressed lightly between the flat backing plate and the first three-dimensional plate, resulting in a bonded and molded two-ply laminate having three-dimensional surface and a relatively flat surface. The Air Permeability of the molded two-ply fabric was about 289 CFM (the mean of three samples, with a standard deviation of 45 CFM).

**Figure 17** is a photograph of the two-ply non-woven tissue making fabric molded against the first three-dimensional plate. **Figure 18** is a height map of a portion of the non-woven tissue making fabric, showing a characteristic peak-to-valley height of about 0.57 mm, somewhat less than the peak-to-valley height of the metal plate.

#### **Prophetic Example:**

A non-woven tissue making fabric may be made from non-woven materials comprising elastomeric components or mechanically configured to be stretchable in the cross-direction, such as neck-bonded nonwoven laminates, such that the non-woven tissue making fabric is extensible in the cross-direction. In one embodiment, the non-woven tissue making fabric is elastically stretchable in the cross-direction but relatively non-stretchable (no more than is customary for conventional woven papermaking fabrics) in the machine direction. A cross-direction stretchable non-woven tissue making fabric may be stretched as embryonic tissue web is formed thereon or prior to placing an embryonic tissue web thereon. The cross-direction-stretched non-woven tissue making fabric may then be relaxed to create cross-directional foreshortening in the tissue web. Contraction of the tissue web may be done as the non-woven tissue making fabric passes over a vacuum box or during through drying, such that differential air pressure helps hold the tissue web in contact with the non-woven tissue making

5 fabric to prevent buckling or separation of the tissue web during contraction. The cross-directional foreshortening of the tissue web in this manner may impart high levels of cross-directional stretch (e.g., equal to or greater than about 9%, about 12%, or about 15%) in the tissue web, and may impart interesting and useful texture to the tissue web.

10 It will be appreciated that the foregoing examples and description, given for purposes of illustration, are not to be construed as limiting the scope of the present invention, which is defined by the following claims and all equivalents thereto.

**We Claim:**

1. An endless non-woven tissue making fabric having a three-dimensional texture suitable for use as a fabric for producing three-dimensional fibrous webs, comprising a plurality of substantially parallel adjoining sections of non-woven material, each section of non-woven material being joined to at least one other adjoining section of non-woven material, the non-woven tissue making fabric having a machine direction, a cross-machine direction, a tissue contacting surface and a tissue machine contacting surface, the tissue machine contacting surface comprising solid matter at a plurality of heights such that the tissue contacting surface of the non-woven tissue making fabric has an Overall Surface Depth of at least 0.2 mm in regions of solid matter on the tissue contacting surface.
2. The endless non-woven tissue making fabric of Claim 1, wherein the three-dimensional texture is provided in the tissue contacting surface ply, layer, or stratum of the endless non-woven tissue making fabric.
3. The endless non-woven tissue making fabric of Claim 1, wherein at least a portion of the tissue contacting surface is removed thereby providing the three-dimensional texture.
4. The endless non-woven tissue making fabric of Claim 3, wherein the removal is applied to the tissue contacting surface of the endless non-woven tissue making fabric by the method selected from the group consisting of: cutting; stamping; laser cutting; laser ablation; drilling; and, any combination thereof.
5. The endless non-woven tissue making fabric of Claim 1, wherein at least a portion of the tissue contacting surface is densified thereby providing the three-dimensional texture.

30

- 6.** The endless non-woven tissue making fabric of Claim 5, wherein the densification is applied to the tissue contacting surface of the endless non-woven tissue making fabric by the method selected from the group consisting of: embossing; stamping; ultrasonic welding; thermal welding; hot pin aperturing; thermal molding, and any combination thereof.
- 7.** The endless non-woven tissue making fabric of Claim 1, wherein at least a portion of the tissue contacting surface has additional material applied to the tissue contacting surface.
- 8.** The endless non-woven tissue making fabric of Claim 7, wherein the material is retained on the tissue contacting surface of the endless non-woven tissue making fabric by the method selected from the group consisting of: adhesives; thermal welding; ultrasonic welding; needling; and any combination thereof.
- 9.** The endless non-woven tissue making fabric of Claim 7, wherein the material added to the tissue contacting surface of the endless non-woven tissue making fabric is selected from the group consisting of: same non-woven material; different non-woven material; permeable material; impermeable; and, any combination thereof.
- 10.** The endless non-woven tissue making fabric of Claim 7, wherein the material is applied by the method of the group consisting of: extruding; ink jet printing; flexographic printing; and, any combination thereof.
- 11.** The endless non-woven tissue making fabric of Claim 10, wherein the adhesive is selected from the group consisting of: hot melt; non-pressure sensitive adhesive; and, the combination thereof.

**12.** The endless non-woven tissue making fabric of Claim 6, wherein the thermal molding provides the three-dimensional texture by the method selected from the group consisting of molding between plates; air differentials; tension; and, any combination thereof.

5

**13.** The endless non-woven tissue making fabric of Claim 1, wherein the three-dimensional texture comprises a repeating pattern.

**14.** The endless non-woven tissue making fabric of Claim 13, wherein the repeating pattern includes a series of raised elements and depressed elements defining a repeating unit cell.

**15.** The endless non-woven tissue making fabric of Claim 14, wherein the repeating unit cell of the repeating pattern includes a width of about 3 mm or greater in the cross-machine direction of the endless non-woven tissue making fabric.

**16.** The endless non-woven tissue making fabric of Claim 14, wherein the repeating unit cell of the repeating pattern includes a length of about 3 mm or greater in the machine direction of the endless non-woven tissue making fabric.

**17.** The endless non-woven tissue making fabric of Claim 14, wherein the repeating unit cell of the repeating pattern includes a percentage value in the machine direction length of the endless non-woven making fabric of about 1% or greater.

**18.** The endless non-woven tissue making fabric of Claim 1, wherein the tissue contacting surface of the endless non-woven tissue making fabric is differently textured than the tissue machine contacting surface of the endless non-woven tissue making fabric.

30

**19.** The endless non-woven tissue making fabric of Claim 1, wherein the tissue machine contacting surface of the endless non-woven tissue making fabric is substantially textured the same as the tissue contacting surface of the endless non-woven tissue making fabric.

5

**20.** The endless non-woven tissue making fabric of Claim 1, wherein the endless non-woven tissue making fabric comprises bi-component binder materials.

**21.** The endless non-woven tissue making fabric of Claim 20, wherein the bi-component binder material includes at least a first portion and a second portion, wherein the first portion has a lower melting point than the second portion.

10

**22.** The endless non-woven tissue making fabric of Claim 1, wherein the endless non-woven tissue making fabric is formed on a carrier fabric.

15

**23.** The endless non-woven tissue making fabric of Claim 22, wherein the endless non-woven tissue making fabric is attached to the carrier fabric.

**24.** The endless non-woven tissue making fabric of Claim 20, wherein the endless non-woven tissue making fabric is comprised of fibers or filaments selected from the group consisting of: spunbond fibers; melt blown fibers; and, combinations thereof.

20

**25.** The endless non-woven tissue making fabric of Claim 1, wherein the non-woven tissue making fabric further comprising a transverse seam.

25

**26.** The endless non-woven tissue making fabric of Claim 1, wherein at least one section of non-woven material has a width substantially the same as the width of the non-woven tissue making fabric.

30



- 27.** The endless non-woven tissue making fabric of Claim 1, wherein at least one section of non-woven material has a width substantially less than the width of the non-woven tissue making fabric.
- 5 **28.** The endless non-woven tissue making fabric of Claim 1, wherein at least one section of non-woven material has a width substantially greater than the width of the non-woven tissue making fabric.
- 29.** The endless non-woven tissue making fabric of Claim 1, wherein each  
10 section of non-woven material has a width substantially less than the width of the non-woven tissue making fabric.
- 30.** The endless non-woven tissue making fabric of Claim 1, wherein the non-woven tissue making fabric does not comprise a woven element.  
15
- 31.** A method of making an endless non-woven tissue making fabric having a three-dimensional texture suitable for use as a fabric for producing three-dimensional fibrous webs comprising:
- 20       a. providing an endless non-woven tissue making fabric having a tissue contacting surface and a tissue machine contacting surface;
- b. passing heated air through a molding device;
- c. passing the endless non-woven tissue making fabric over a surface of the molding device, wherein the surface of the molding device includes a textured molding surface; and,
- 25       d. conforming at least a portion of the endless non-woven tissue making fabric to the textured molding surface of the molding device, thereby forming a three-dimensional texture on the endless non-woven tissue making fabric.
- 30 **32.** The method of Claim 31, wherein the molding device further comprises a suction roll.

- 33.** The method of Claim 32, wherein the suction roll provides a zone of vacuum.
- 34.** The method of Claim 31, further comprising providing a cooling device to  
5 cool the endless non-woven tissue making fabric.
- 35.** The method of Claim 31, wherein the molding elements of the molding device are raised elements.
- 10 **36.** The method of Claim 31, wherein the molding elements of the molding device have the shape as selected from the group consisting of: sine wave-shaped; triangle-shaped; square wave-shaped; irregular-shaped; and, any combination thereof.
- 15 **37.** The method of Claim 31, wherein the heated air is provided by an air knife.
- 38.** The method of Claim 31, wherein the molding elements of the molding device are porous.
- 20 **39.** The method of Claim 28, wherein the molding elements are comprised of material selected from the group consisting of: sintered metal; finely drilled metal; finely drilled plastic; sintered ceramic; ceramic foam; and, any combination thereof.
- 25 **40.** The method of Claim 31, further comprising contacting the tissue contacting surface of the endless non-woven tissue making fabric with the surface of the molding device.

- 41.** The method of Claim 40, wherein at least a portion of the tissue contacting surface of the endless non-woven tissue making fabric conforms with the surface of the molding device
- 5 **42.** The method of Claim 31, further comprising contacting the tissue machine contacting surface of the endless non-woven tissue making fabric with the surface of the molding device.
- 43.** The method of Claim 31, wherein the three-dimensional texture comprises a  
10 repeating pattern.
- 44.** The method of Claim 43, wherein the repeating pattern includes a series of raised elements and depressed elements defining a repeating unit cell.
- 15 **45.** The method of Claim 44, wherein the repeating unit cell of the repeating pattern includes a width of about 3 mm or greater in the cross-machine direction of the endless non-woven tissue making fabric.
- 46.** The method of Claim 44, wherein the repeating unit cell of the repeating  
20 pattern includes a length of about 3 mm or greater in the machine direction of the endless non-woven tissue making fabric.
- 47.** The method of Claim 44, wherein the repeating unit cell of the repeating  
25 pattern includes a percentage value in the machine direction length of the endless non-woven making fabric of about 1% or greater.
- 48.** The method of Claim 31, wherein the tissue contacting surface of the  
endless non-woven tissue making fabric is differently textured than the tissue  
machine contacting surface of the endless non-woven tissue making fabric.

- 49.** The method of Claim 31, wherein the tissue contacting surface of the endless non-woven tissue making fabric is substantially textured the same as the tissue machine contacting surface of the endless non-woven tissue making fabric.
- 5 **50.** The method of Claim 55, wherein the endless non-woven tissue making fabric comprises multi-component binder materials.
- 51.** The method of Claim 50, wherein the multi-component binder material includes at least a first portion and a second portion, wherein the first portion has a  
10 lower melting point than the second portion.
- 52.** The method of Claim 50, wherein the multi-component binder material is selected from the group consisting of: bi-component concentric sheath-core; bi-component asymmetric sheath-core; bi-component side-by-side; and, any  
15 combination thereof.
- 53.** The method of Claim 31, wherein the endless non-woven tissue making fabric is formed on a carrier fabric.
- 20 **54.** The method of Claim 53, wherein the endless non-woven tissue making fabric is attached to the carrier fabric.
- 55.** The method of Claim 50, wherein the endless non-woven tissue making fabric is comprised of fibers or filaments selected from the group consisting of:  
25 spunbond fibers; melt blown fibers; and, combinations thereof.
- 56.** The method of Claim 31, further comprising providing a gas pervious roll having a surface wherein a nip is formed between the surface of the gas pervious roll and the surface of the molding device.

30

**57.** The method of Claim 56, wherein the surface of the gas pervious roll includes molding elements.

**58.** The method of Claim 57, wherein the surface of the gas pervious roll including the molding elements is a textured sleeve.

**59.** The method of Claim 57, wherein the molding elements of the gas pervious roll are raised elements.

**60.** The method of Claim 59, wherein the surface of the gas pervious roll including the raised elements is a textured sleeve.

**61.** The method of Claim 57, wherein the molding elements of the gas pervious roll mesh with the raised elements of the molding device.

15

**62.** The method of Claim 31, wherein the tissue contacting surface of the endless non-woven tissue making fabric includes a three-dimensional texture and the tissue machine contacting surface of the endless non-woven tissue making fabric includes a three-dimensional texture.

20

**63.** The method of Claim 57, wherein the tissue contacting surface of the endless non-woven tissue making fabric includes a three-dimensional texture and the tissue machine contacting surface of the endless non-woven tissue making fabric includes a three-dimensional texture.

25

**64.** The method of Claim 31, wherein the non-woven tissue making fabric does not comprise a woven element.

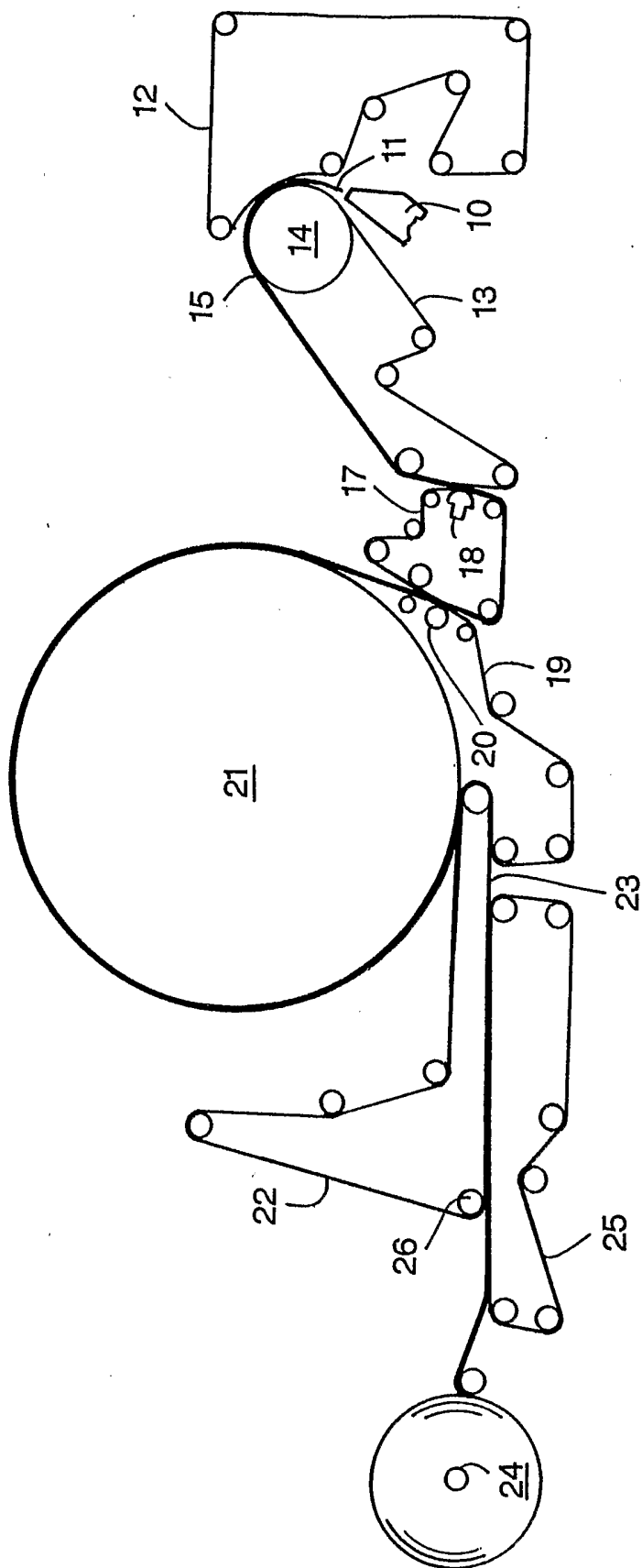

Figure 1

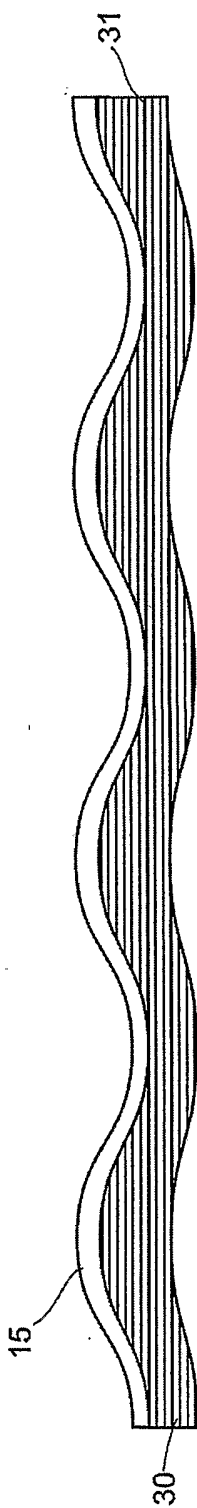

Figure 2A

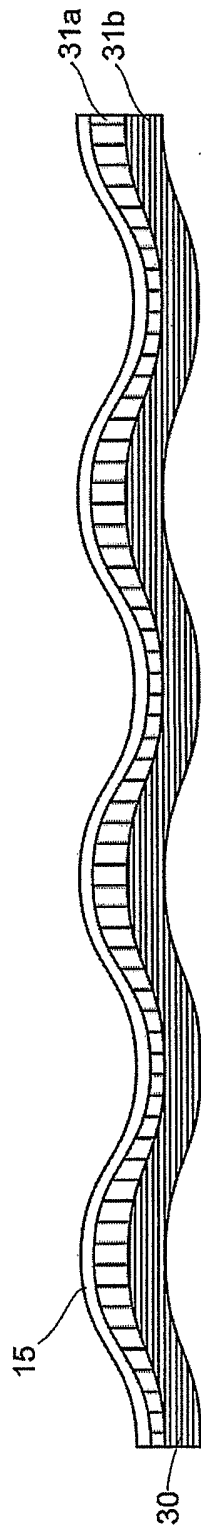

Figure 2B

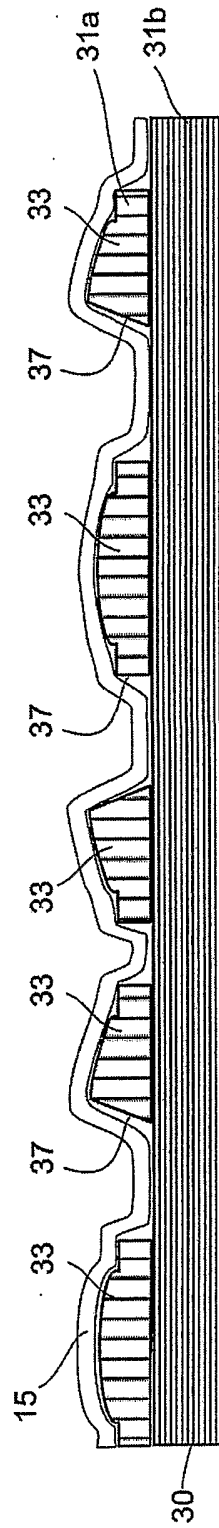

Figure 2C

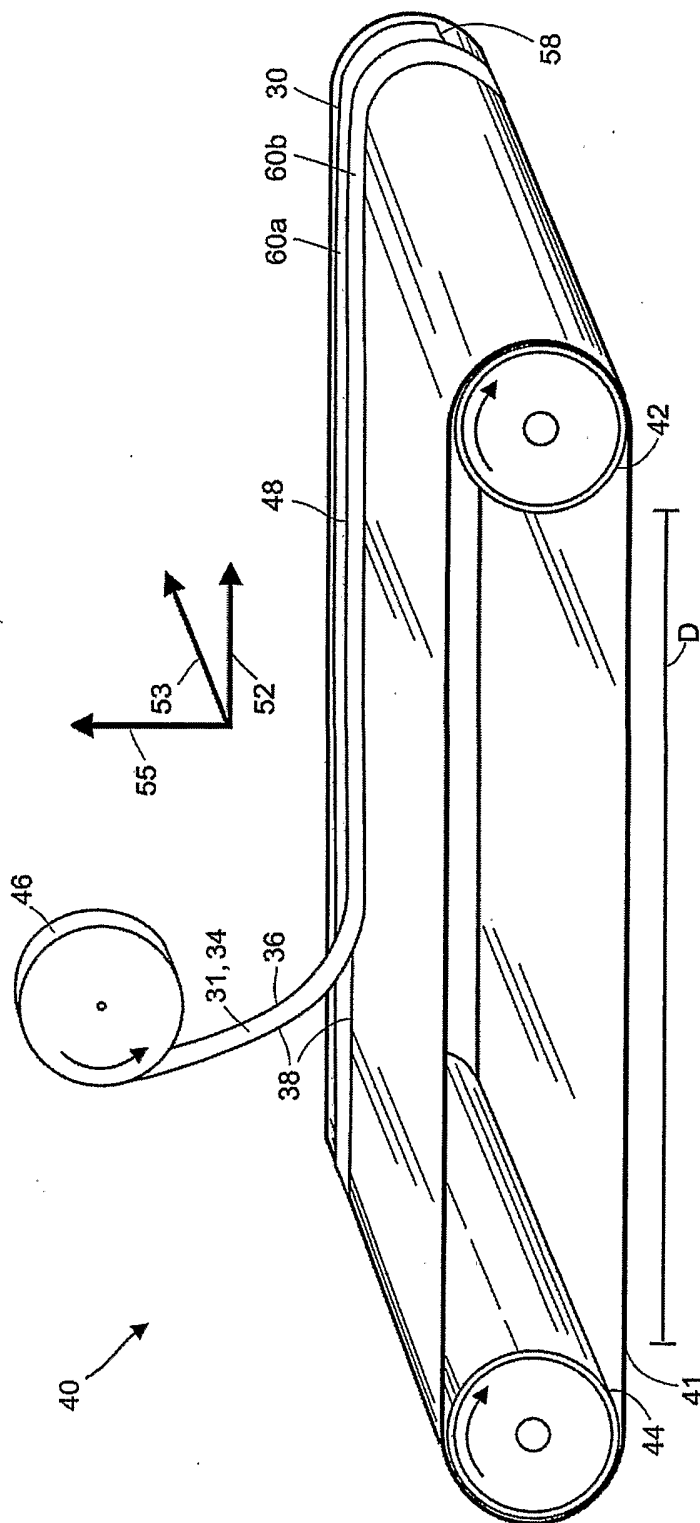

Figure 3



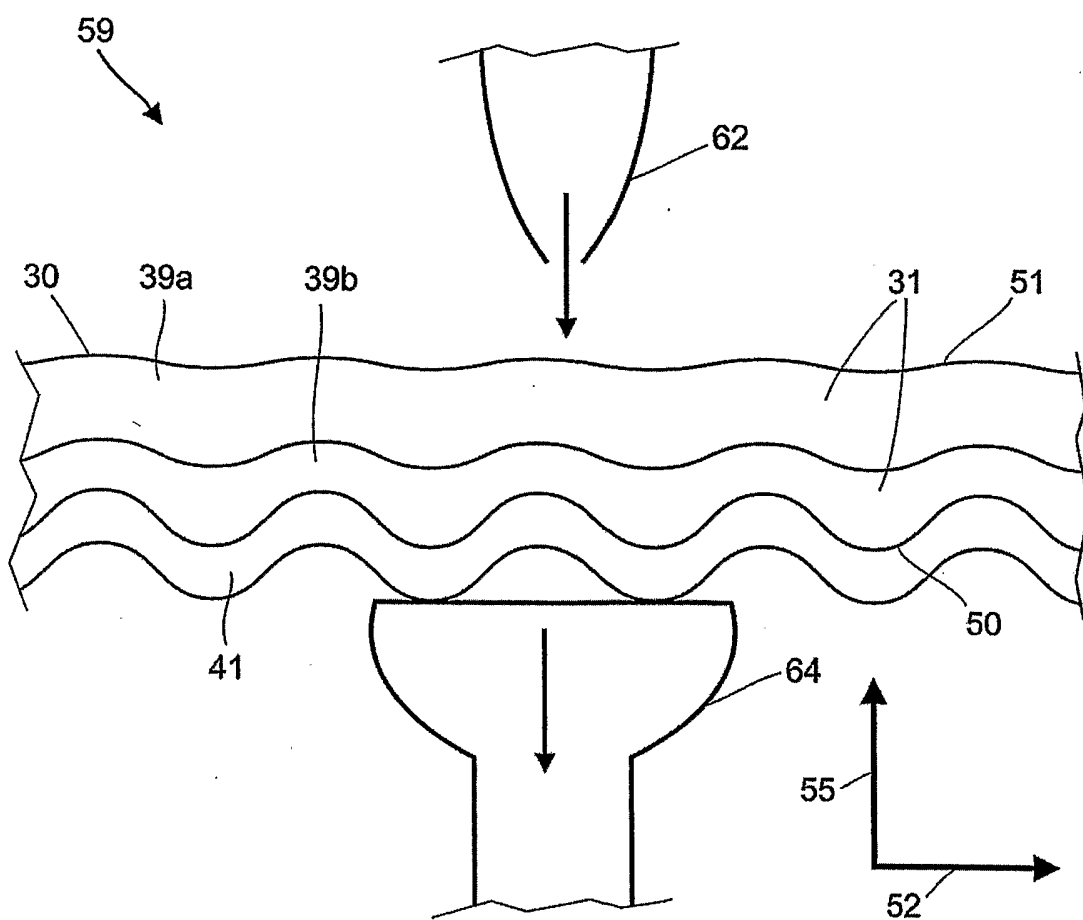

Figure 4

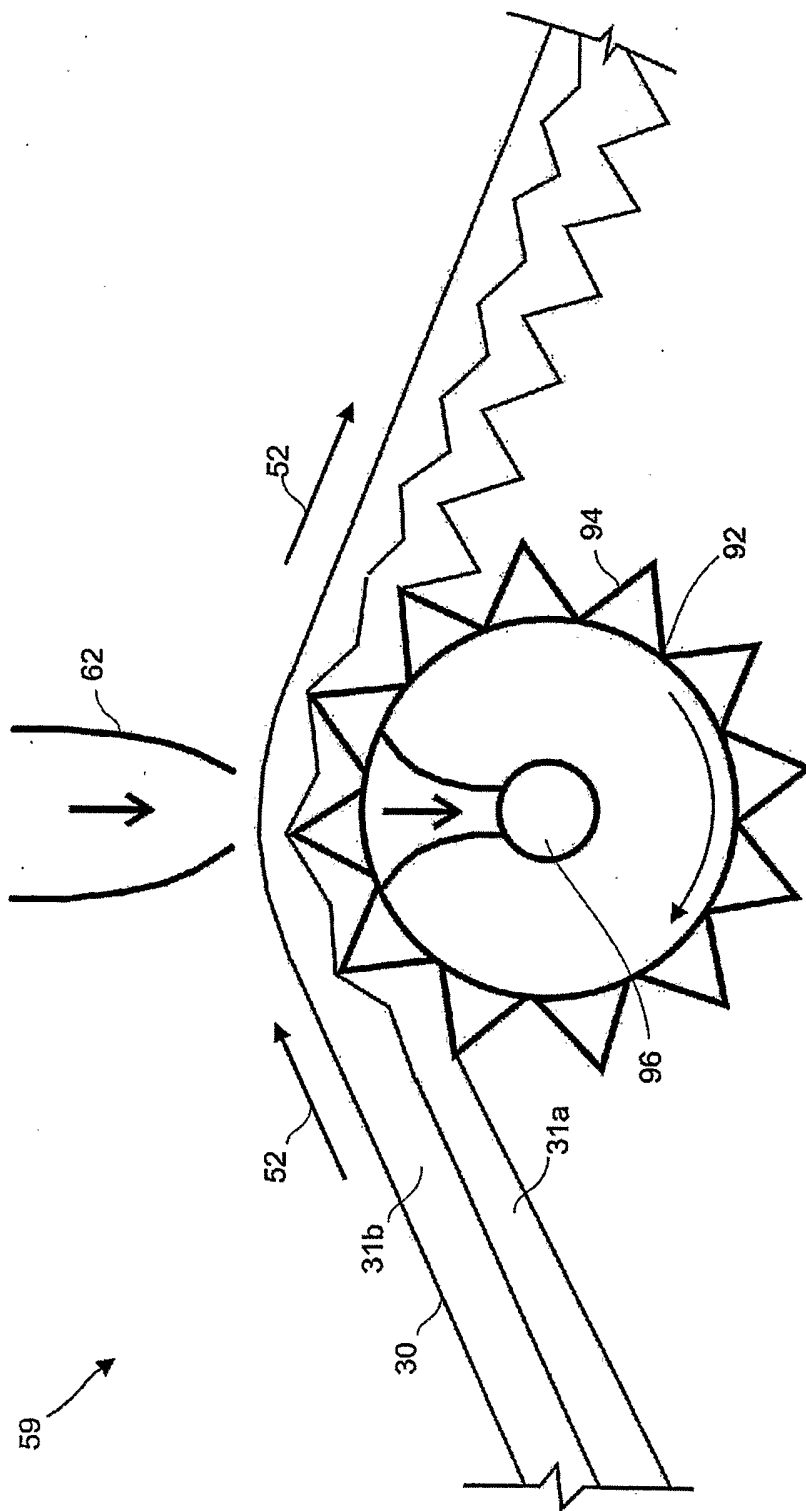

Figure 5

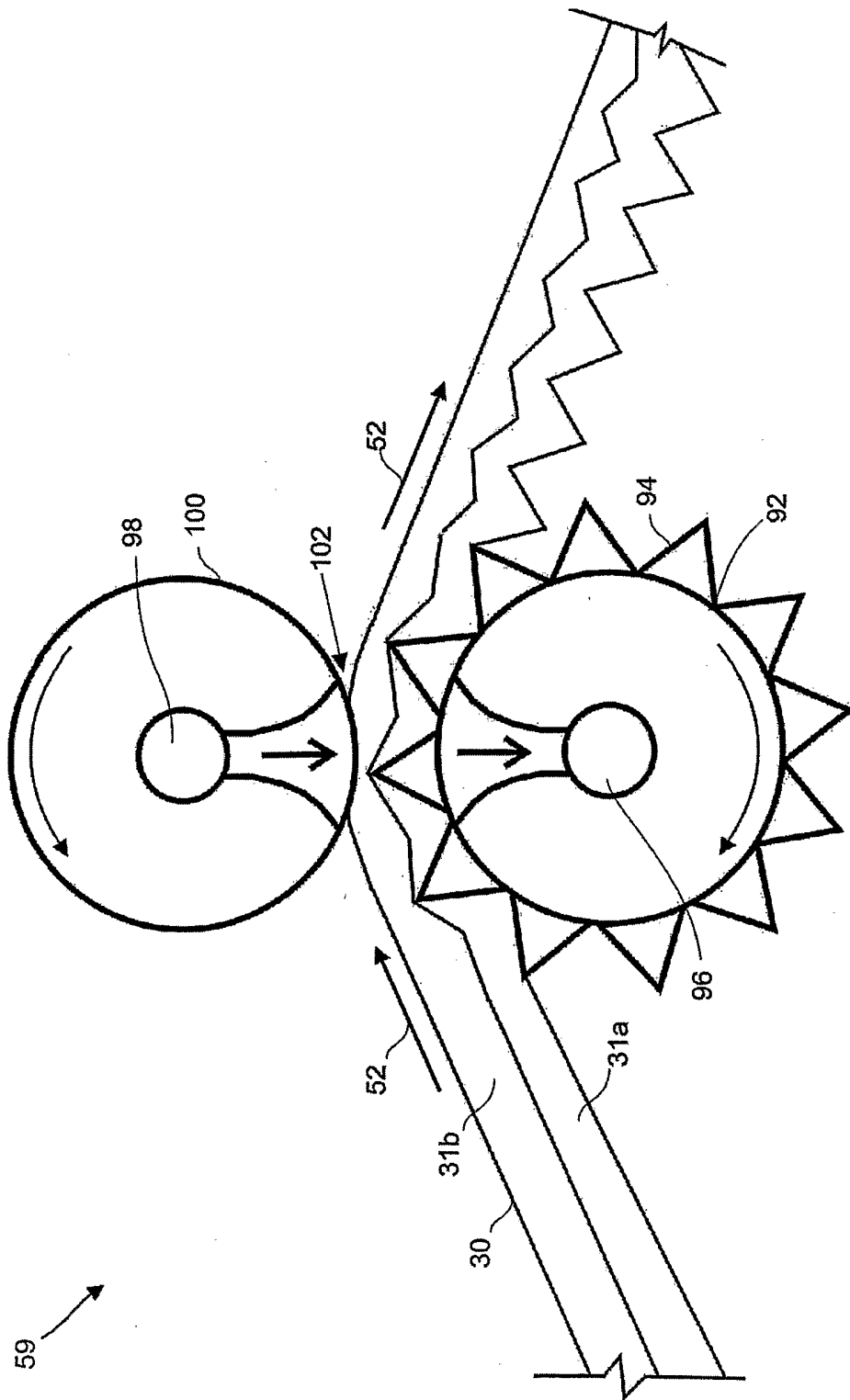

Figure 6

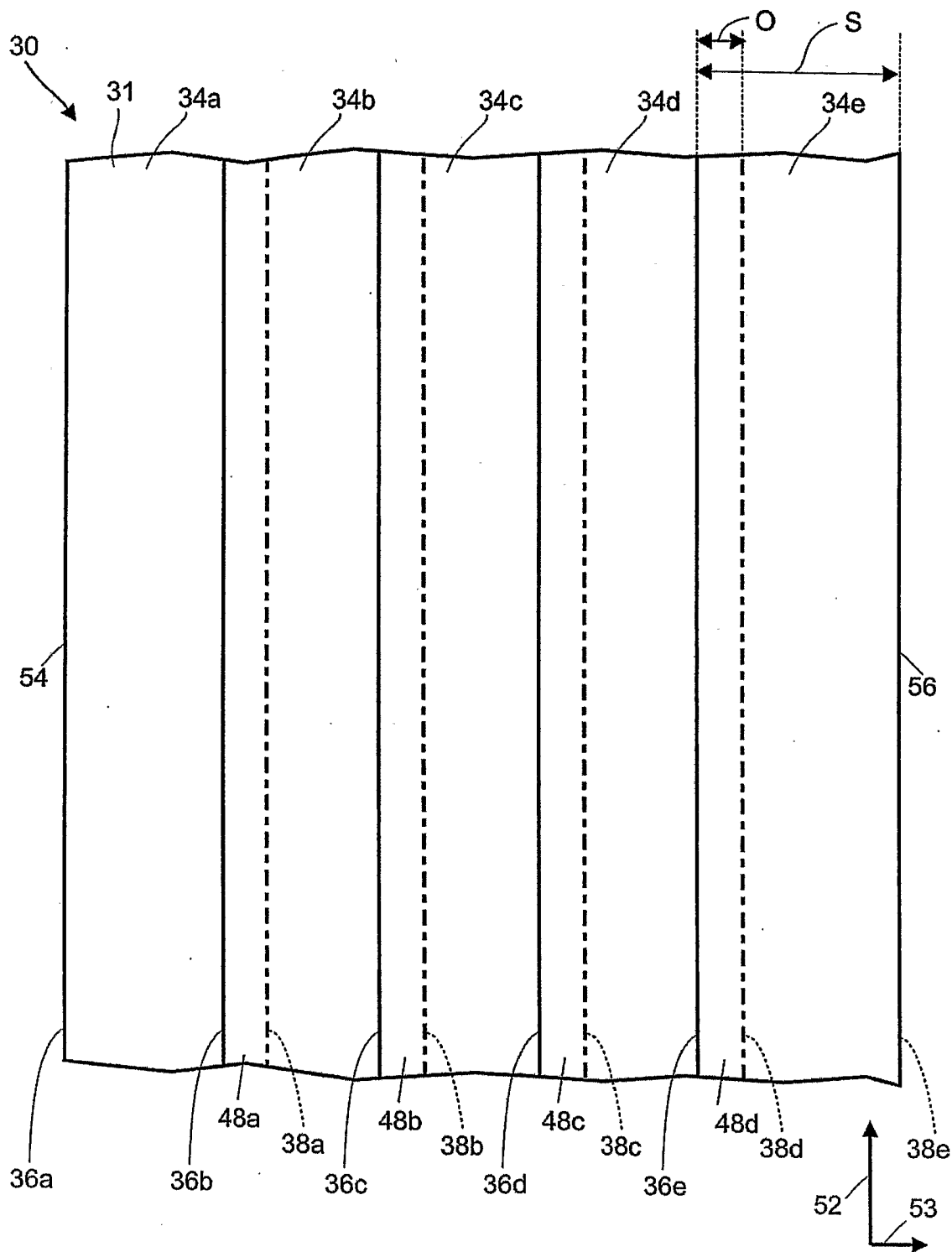

Figure 7

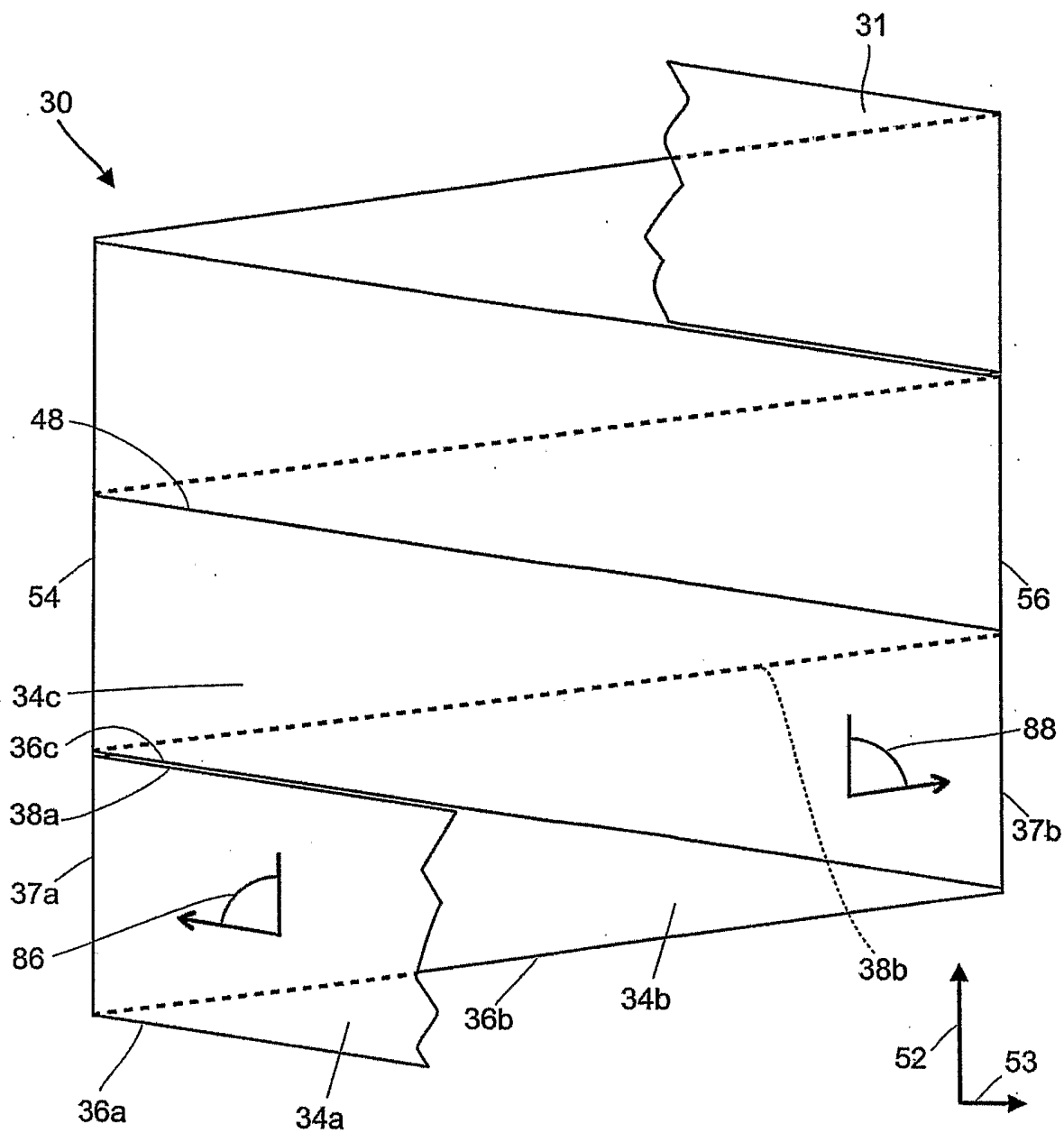

Figure 8A



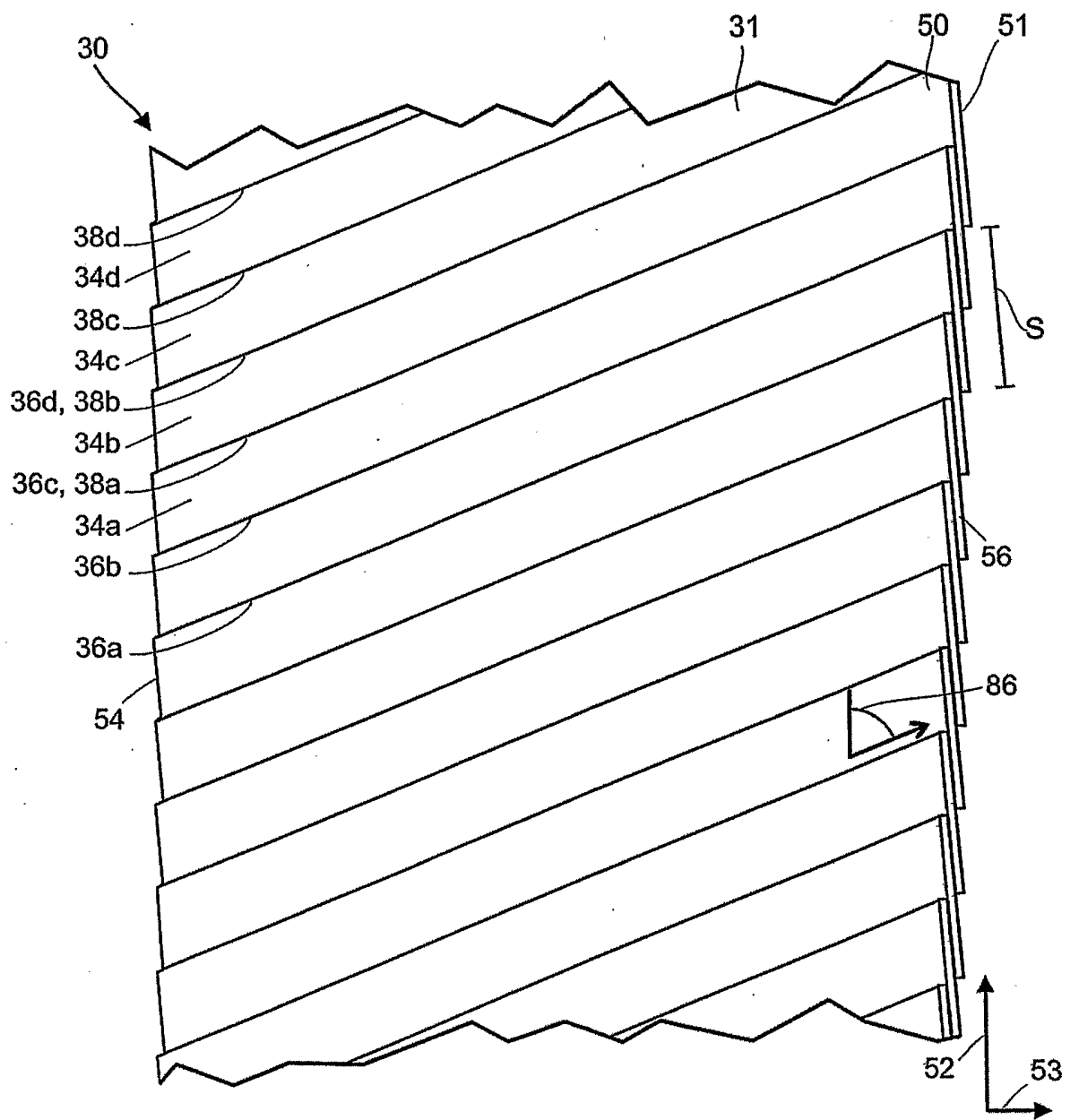

Figure 9





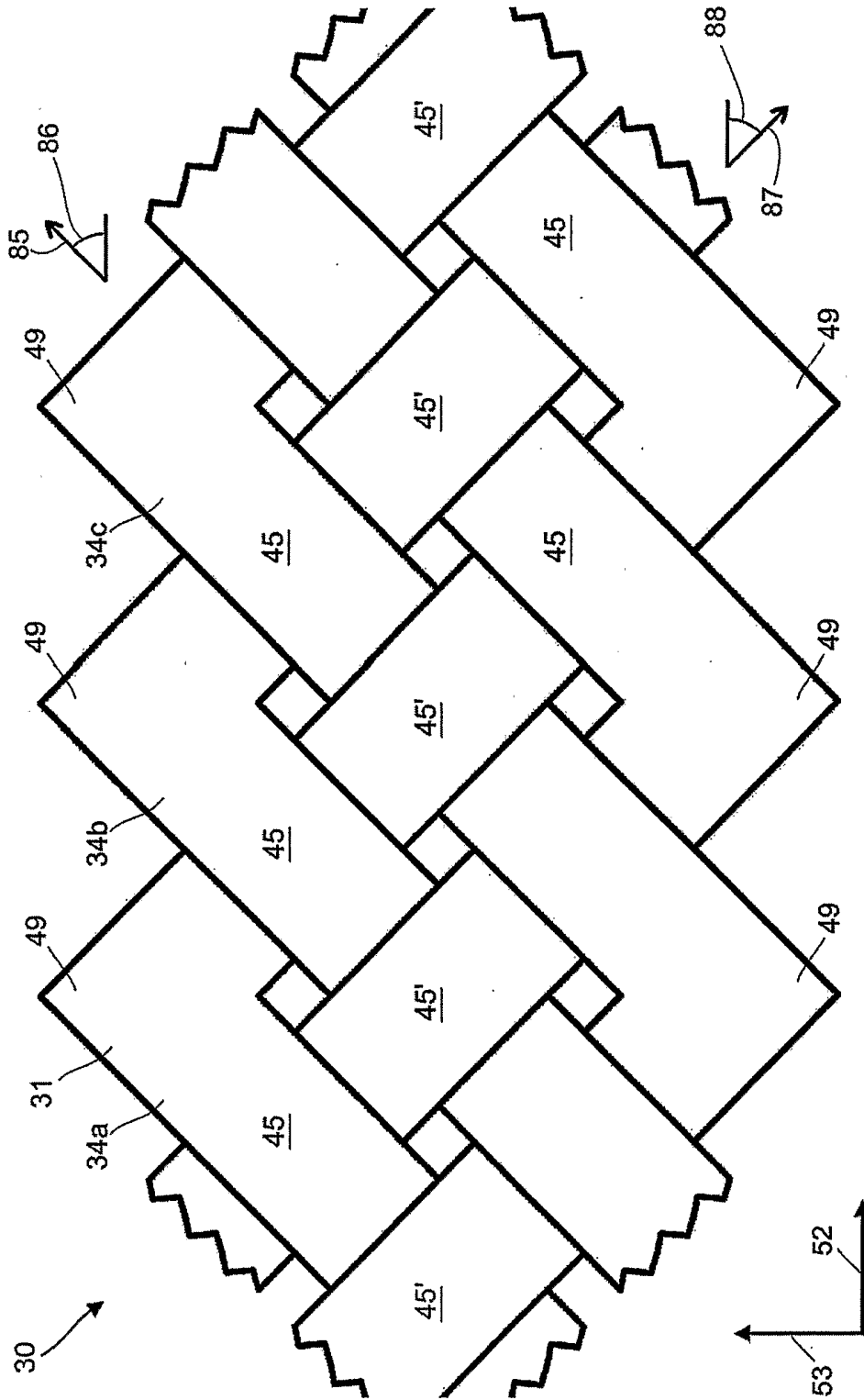

Figure 11

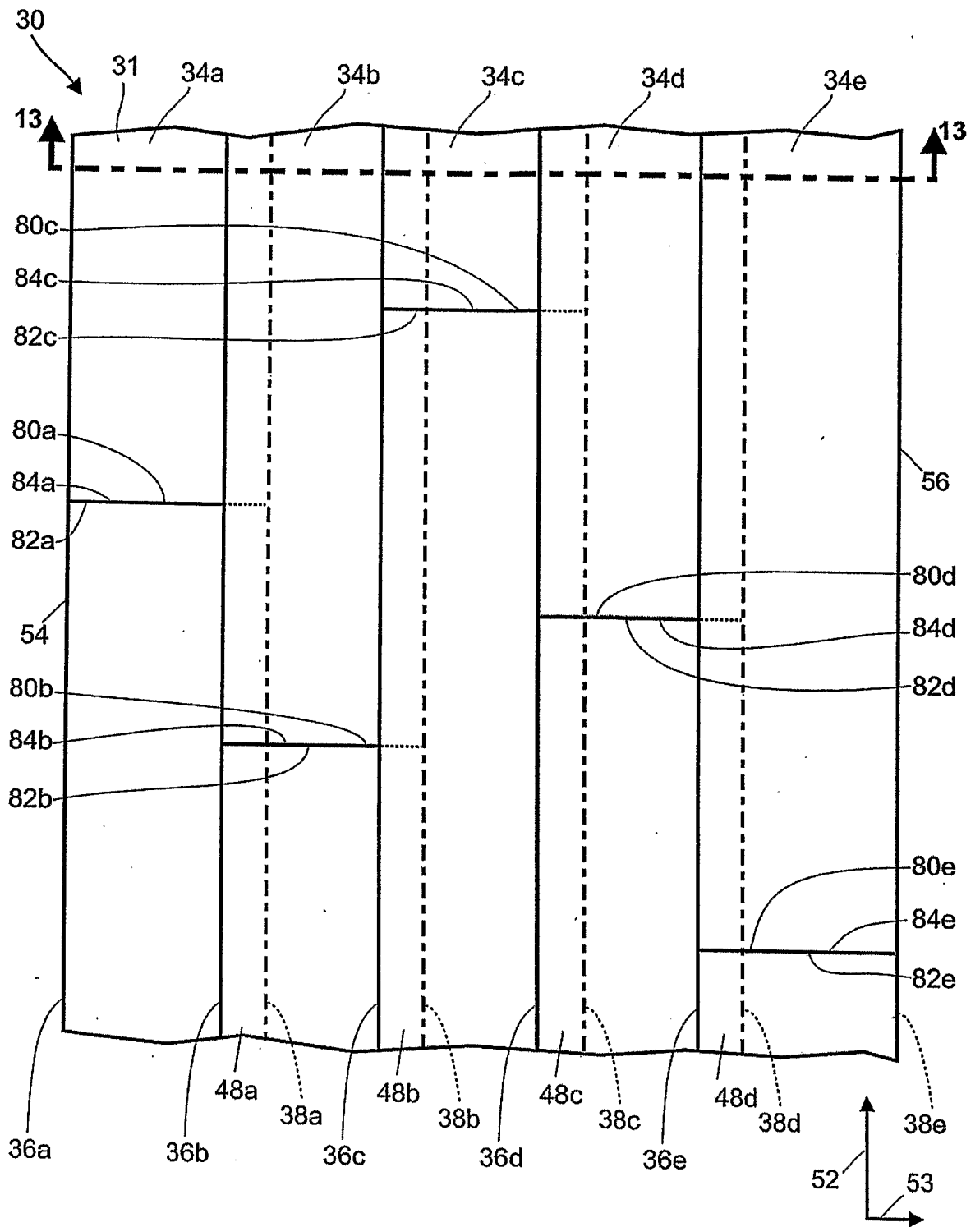

Figure 12

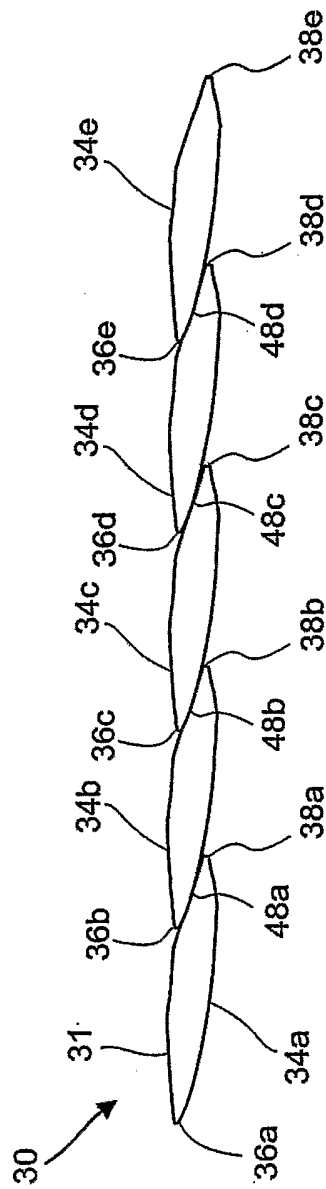

Figure 13

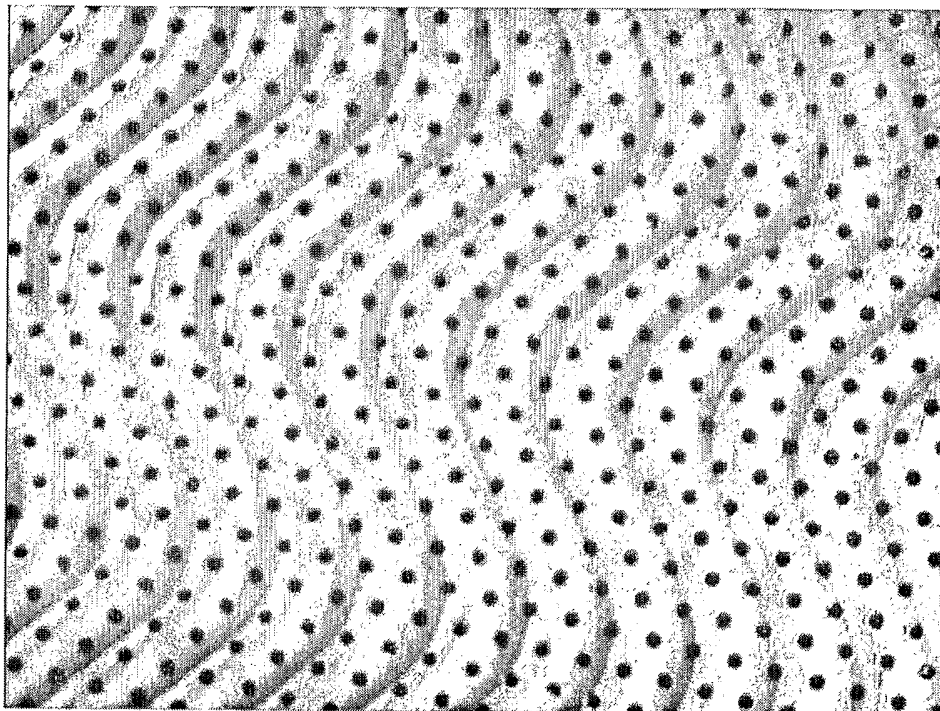

Figure 14

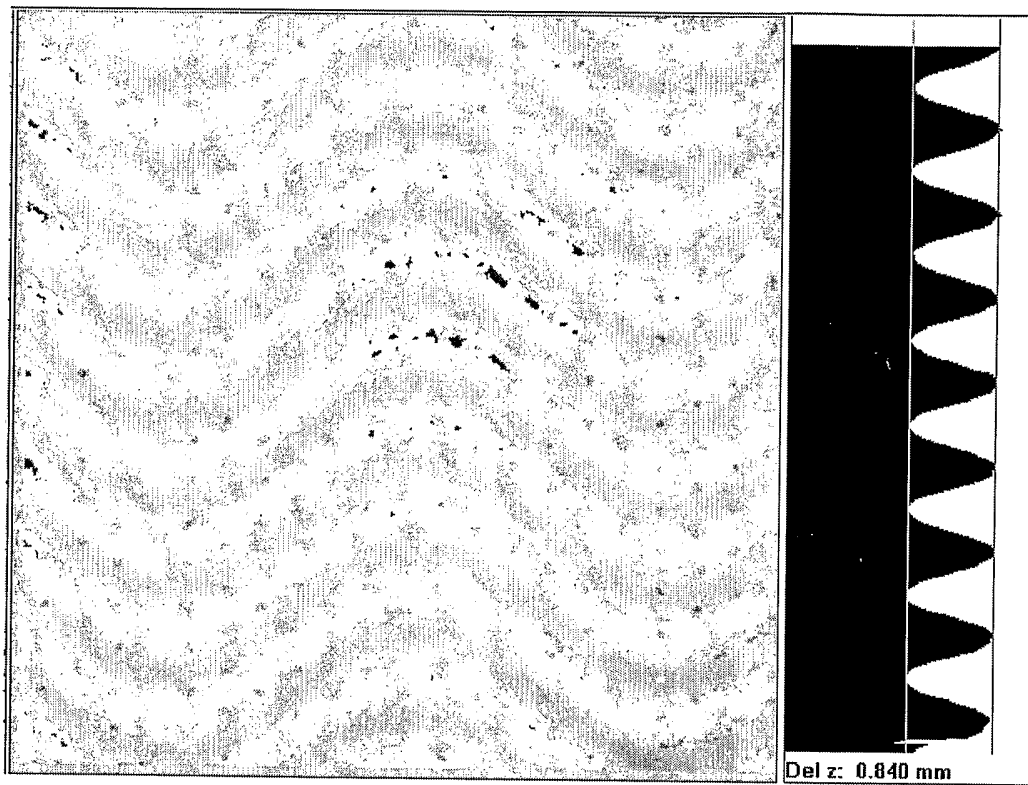

Figure 15

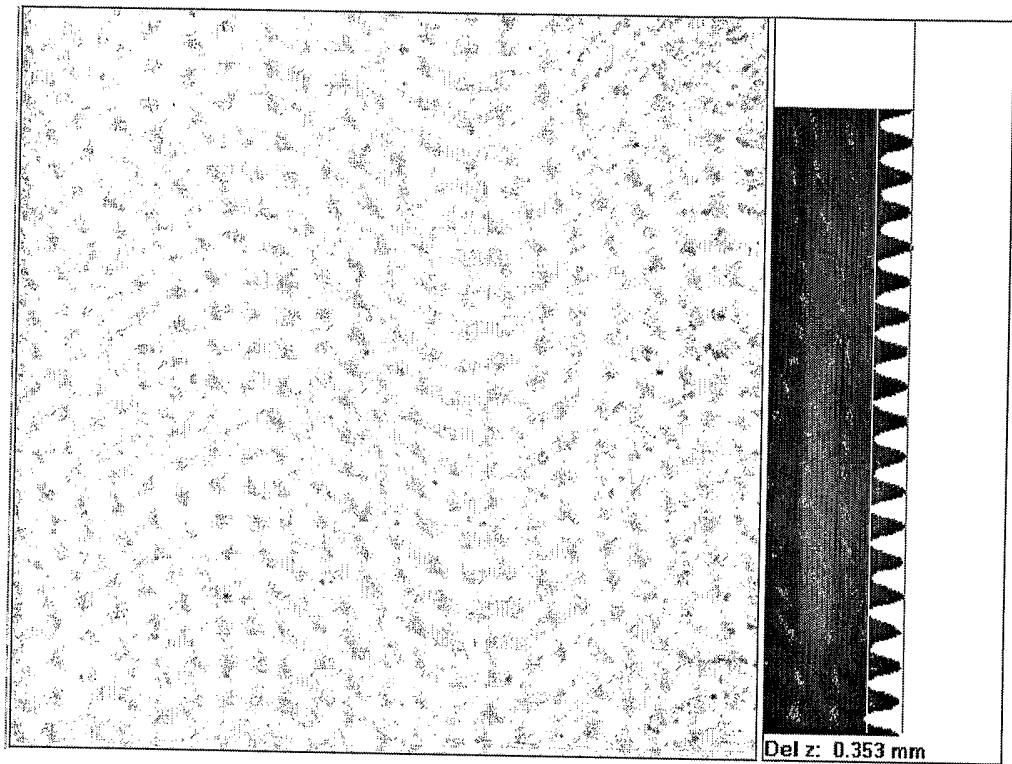

Figure 16

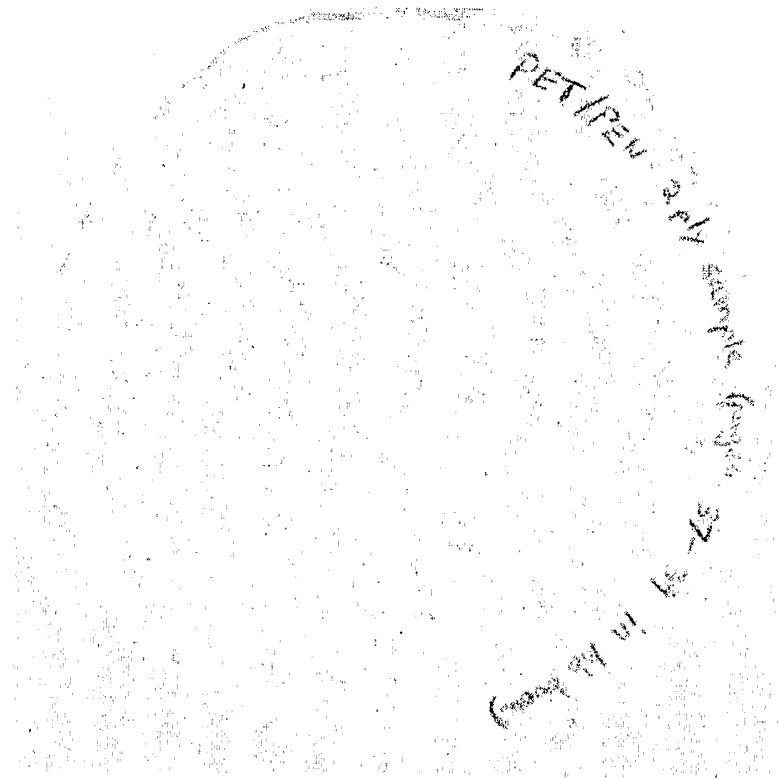

Figure 17

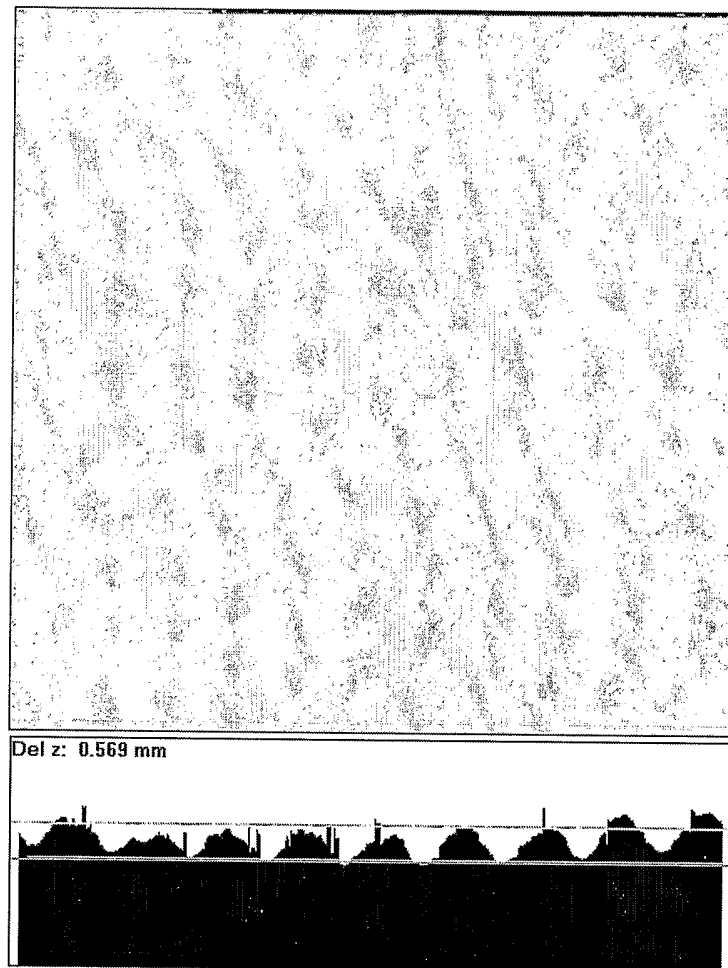

Figure 18



# INTERNATIONAL SEARCH REPORT

International Application No  
PCT/US 03/13484

**A. CLASSIFICATION OF SUBJECT MATTER**  
IPC 7 D21F11/00

According to International Patent Classification (IPC) or to both national classification and IPC

**B. FIELDS SEARCHED**

Minimum documentation searched (classification system followed by classification symbols)  
IPC 7 D21F

Documentation searched other than minimum documentation to the extent that such documents are included in the fields searched

Electronic data base consulted during the international search (name of data base and, where practical, search terms used)

EPO-Internal, WPI Data, PAJ

**C. DOCUMENTS CONSIDERED TO BE RELEVANT**

Category °	Citation of document, with indication, where appropriate, of the relevant passages	Relevant to claim No.
A	US 6 120 642 A (BURAZIN MARK ALAN ET AL) 19 September 2000 (2000-09-19) column 1, line 26 -column 1, line 27 column 2, line 10 -column 2, line 40 column 5, line 51 -column 6, line 54 column 8, line 6 -column 8, line 27 column 9, line 42 -column 9, line 50; figures 1,2; examples 1-3 ---	1-64
A	US 6 080 691 A (BURAZIN MARK ALAN ET AL) 27 June 2000 (2000-06-27) claims 1-5; figures 1,2 ---	1-64
A	EP 0 677 612 A (KIMBERLY CLARK CO) 18 October 1995 (1995-10-18) column 7, line 40 -column 8, line 31; claims 1,2,10,14-16 ---	1-64
	-/--	

Further documents are listed in the continuation of box C.

Patent family members are listed in annex.

° Special categories of cited documents :

- \*A\* document defining the general state of the art which is not considered to be of particular relevance
- \*E\* earlier document but published on or after the international filing date
- \*L\* document which may throw doubts on priority claim(s) or which is cited to establish the publication date of another citation or other special reason (as specified)
- \*O\* document referring to an oral disclosure, use, exhibition or other means
- \*P\* document published prior to the international filing date but later than the priority date claimed

- \*T\* later document published after the international filing date or priority date and not in conflict with the application but cited to understand the principle or theory underlying the invention
- \*X\* document of particular relevance; the claimed invention cannot be considered novel or cannot be considered to involve an inventive step when the document is taken alone
- \*Y\* document of particular relevance; the claimed invention cannot be considered to involve an inventive step when the document is combined with one or more other such documents, such combination being obvious to a person skilled in the art.
- \*&\* document member of the same patent family

Date of the actual completion of the international search

1 September 2003

Date of mailing of the international search report

09/09/2003

Name and mailing address of the ISA

European Patent Office, P.B. 5818 Patentlaan 2  
NL - 2280 HV Rijswijk  
Tel. (+31-70) 340-2040, Tx. 31 651 epo nl,  
Fax: (+31-70) 340-3016

Authorized officer

Demay, S

## INTERNATIONAL SEARCH REPORT

International Application No  
PCT/US 03/13484

C.(Continuation) DOCUMENTS CONSIDERED TO BE RELEVANT		
Category °	Citation of document, with indication, where appropriate, of the relevant passages	Relevant to claim No.
A	EP 1 236 827 A (KIMBERLY CLARK CO) 4 September 2002 (2002-09-04) paragraphs '0013!', '0016!', '0053!', '0054!', '0107!', '0108!', '0144!; claims 21, 39 ---	1-64
A	EP 0 999 306 A (ALBANY INT CORP) 10 May 2000 (2000-05-10) paragraphs '0012!'-'0015!; claims 1, 14, 15, 19, 26 ---	1-64
A	WO 02 41815 A (KIMBERLY CLARK CO) 30 May 2002 (2002-05-30) page 13, line 17 -page 14, line 2; claims 1, 3; figure 2 ---	1-64
A	US 4 849 054 A (KLOWAK BERNARD G) 18 July 1989 (1989-07-18) cited in the application column 4, line 61 -column 5, line 10 column 7, line 34 -column 7, line 64 ---	1-64
A	WO 98 01618 A (SCAPA GROUP PLC) 15 January 1998 (1998-01-15) claims 1-13 -----	1-64

## INTERNATIONAL SEARCH REPORT

International Application No  
PCT/US 03/13484

Patent document cited in search report		Publication date	Patent family member(s)	Publication date
US 6120642	A	19-09-2000	US 6461474 B1	08-10-2002
			AT 237715 T	15-05-2003
			AU 3670797 A	26-03-1998
			BR 9711694 A	24-08-1999
			DE 69721018 D1	22-05-2003
			EP 0925404 A1	30-06-1999
			JP 2001501261 T	30-01-2001
			US 6080691 A	27-06-2000
			WO 9810142 A1	12-03-1998
			ZA 9707002 A	19-02-1998
US 6080691	A	27-06-2000	AT 237715 T	15-05-2003
			AU 3670797 A	26-03-1998
			BR 9711694 A	24-08-1999
			DE 69721018 D1	22-05-2003
			EP 0925404 A1	30-06-1999
			JP 2001501261 T	30-01-2001
			US 6120642 A	19-09-2000
			WO 9810142 A1	12-03-1998
			US 6461474 B1	08-10-2002
			ZA 9707002 A	19-02-1998
EP 0677612	A	18-10-1995	US 5672248 A	30-09-1997
			AU 690960 B2	07-05-1998
			AU 1641295 A	19-10-1995
			AU 722580 B2	10-08-2000
			AU 3499099 A	19-08-1999
			AU 705757 B2	03-06-1999
			AU 7743998 A	08-10-1998
			BR 9501524 A	14-11-1995
			CA 2134594 A1	13-10-1995
			CA 2142805 A1	13-10-1995
			CN 1306122 A	01-08-2001
			CN 1120616 A , B	17-04-1996
			DE 69518784 D1	19-10-2000
			DE 69518784 T2	12-04-2001
			EP 0677612 A2	18-10-1995
			ES 2149290 T3	01-11-2000
			FR 2718470 A1	13-10-1995
			FR 2735155 A1	13-12-1996
			GB 2288614 A , B	25-10-1995
			GB 2319537 A , B	27-05-1998
			GB 2319538 A , B	27-05-1998
			GB 2319539 A , B	27-05-1998
			GB 2324314 A , B	21-10-1998
			GB 2324315 A , B	21-10-1998
			GB 2324316 A , B	21-10-1998
			GB 2324317 A , B	21-10-1998
			JP 8003890 A	09-01-1996
			US 5746887 A	05-05-1998
			US 6017417 A	25-01-2000
			ZA 9502942 A	20-12-1995
EP 1236827	A	04-09-2002	US 5990377 A	23-11-1999
			EP 1236827 A1	04-09-2002
			AU 6464698 A	20-10-1998
			AU 738012 B2	06-09-2001
			AU 6575798 A	20-10-1998

## INTERNATIONAL SEARCH REPORT

International Application No  
PCT/US 03/13484

Patent document cited in search report		Publication date	Patent family member(s)	Publication date
EP 1236827	A		BR 9808031 A	08-03-2000
			EP 0969787 A1	12-01-2000
			JP 2001521590 T	06-11-2001
			TW 410154 B	01-11-2000
			US 2002103469 A1	01-08-2002
			US 2002107495 A1	08-08-2002
			US 2002099347 A1	25-07-2002
			WO 9842289 A1	01-10-1998
			WO 9842290 A1	01-10-1998
			US 6395957 B1	28-05-2002
			ZA 9802342 A	22-09-1998
EP 0999306	A	10-05-2000	US 6554963 B1	29-04-2003
			AU 731585 B2	05-04-2001
			AU 4014299 A	04-05-2000
			BR 9902742 A	30-05-2000
			CN 1254642 A	31-05-2000
			EP 0999306 A2	10-05-2000
			JP 2000282385 A	10-10-2000
			KR 2000034876 A	26-06-2000
			NO 995327 A	03-05-2000
			ZA 9904108 A	28-03-2000
WO 0241815	A	30-05-2002	AU 4156302 A	03-06-2002
			CA 2424752 A1	30-05-2002
			WO 0241815 A2	30-05-2002
US 4849054	A	18-07-1989	NONE	
WO 9801618	A	15-01-1998	AT 210758 T	15-12-2001
			AU 2706397 A	02-02-1998
			AU 3602897 A	02-02-1998
			CA 2261204 A1	15-01-1998
			DE 69709115 D1	24-01-2002
			DE 69709115 T2	25-07-2002
			EP 0914518 A1	12-05-1999
			ES 2169861 T3	16-07-2002
			WO 9801618 A1	15-01-1998
			WO 9801779 A1	15-01-1998
			US 6071837 A	06-06-2000
			ZA 9704623 A	30-12-1997