

N. F. BRENT.
Car-Coupling.

No. 219,206.

Patented Sept. 2, 1879.

Fig. 1.

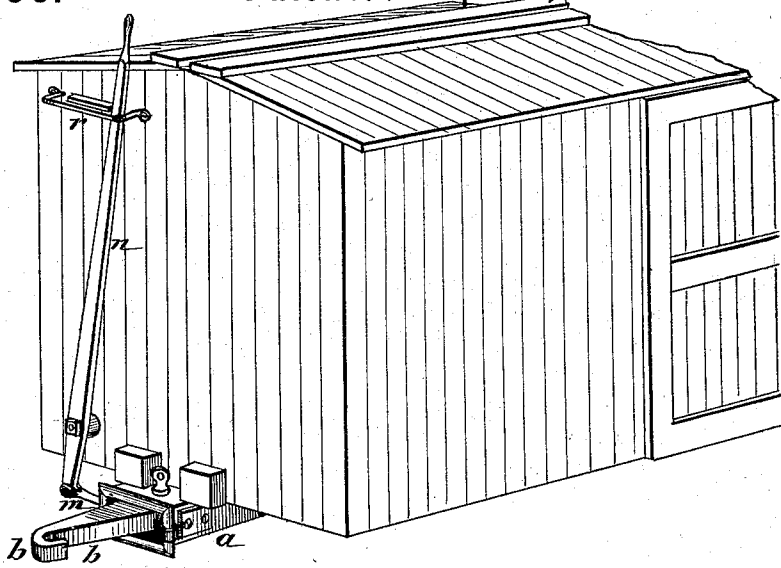

Fig. 2.

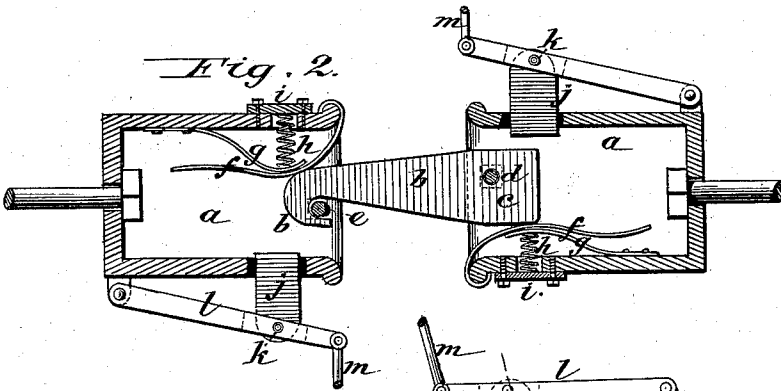

Fig. 3.

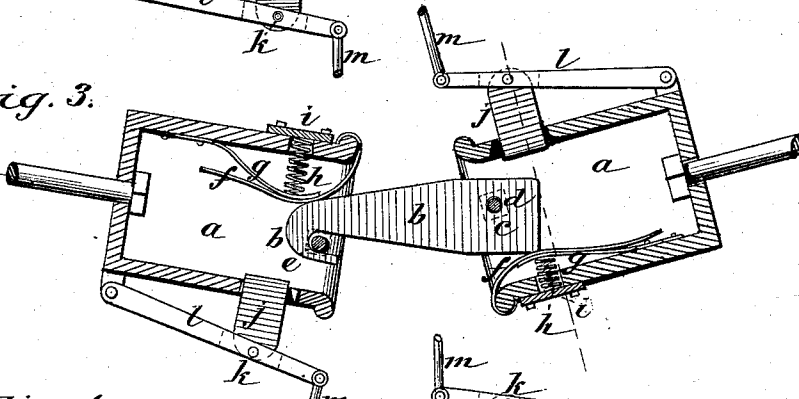
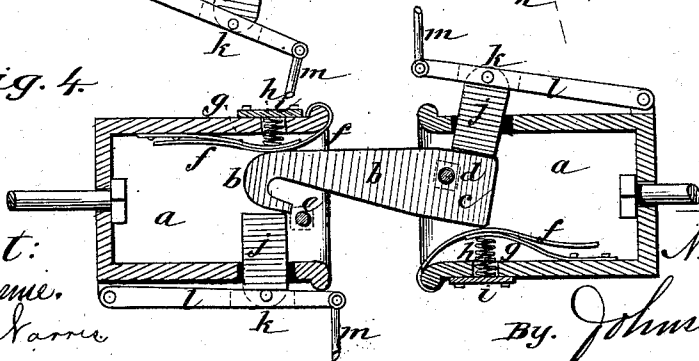

Fig. 4.



Attest:
Ed. Penne,
Doyd Name

Inventor:
N. F. Brent
By. Johnson and Johnson
Attys

UNITED STATES PATENT OFFICE.

NATHANIEL F. BRENT, OF STILLWATER, MINNESOTA.

IMPROVEMENT IN CAR-COUPINGS.

Specification forming part of Letters Patent No. 219,206, dated September 2, 1879; application filed July 7, 1879.

To all whom it may concern:

Be it known that I, NATHANIEL F. BRENT, of Stillwater, in the county of Washington and State of Minnesota, have invented certain new and useful Improvements in Car-Couplings, of which the following is a specification.

My improved car-coupling is adapted for use with freight-cars, and it is of that kind in which a single gripe-hook at one end of the coupling-bar works with coupling-pins, and is held in position for self-coupling by springs.

My improvement is more especially adapted for increasing the security of the coupling in the use of the single gripe-hook bar, as will be hereinafter described, and specifically pointed out in the claims.

Referring to the accompanying drawings, Figure 1 represents a view in perspective of one end of a car with my improved coupling applied thereto; Fig. 2, a horizontal section of the device as coupled with the draw-heads of two cars; Fig. 3, a similar section, showing the coupling in turning curves; and Fig. 4, a similar section, showing the manner of uncoupling the gripe-hook.

The draw-heads are wrought or cast iron or wooden boxes *a*, firmly bolted to the cars, and the coupling-bar is a gripe-hook, *b*, having a straight shank, *c*, which extends within one of the draw-heads some distance, and to which it is secured by a pin, *d*, passing through the draw-head. The opposite draw-head has a similar pin, *e*, over which the hook *b* of the coupling-bar catches to couple the cars.

The draw-heads of each car are provided on their inner right sides (facing the end of the car) with springs having a peculiar relation to each other, and adapted to bear one set upon the back of the hook end and the other set upon the opposite side of the shank of the bar, so as to render the coupling of the gripe-hook secure when coupled. The inner one, *f*, of each set of springs is secured at the mouth of the draw-head, and, extending back, forms one side of the draw-head, and bears against a second shorter spring, *g*, secured to the inner wall of the draw-head and extending to the front as far as the coupling-pin, while a third spiral spring, *h*, lies crosswise in the wall of the draw-head in a position to bear

upon the outer end of the second plate-spring, thus bringing the meeting ends of the short plate-spring and of the spiral spring to bear upon the inner plate-spring, *f*, at a point to exert their force in one draw-head directly upon the back of the hook end *b*, and in the other draw-head directly upon the shank *c* on the opposite side of the coupling-bar, so that while one set of springs holds the hook over the pin the other set presses upon the bar-shank back of the other pin, so as to produce the same effect. The springs, therefore, of each draw-head co-operate to hold the hook end of the coupling-bar in secure position with the coupling-pin; and especially is this security rendered effective as the cars are turning curves, for in such case the deflection of the coupling-bar from a right line brings into action both sets of re-enforcing springs to bind the hook upon the pin, as shown in Fig. 3. This arrangement of the springs also adapts the hook to be used alike in either of the approaching cars and to have the same bearings upon its hook and shank. Such arrangement of the springs is also important in allowing the gripe-hook to couple cars of different heights and to safely maintain such coupling.

The supplemental springs re-enforce the main spring and keep it always effective by acting as cushions or stays thereto, and the spiral spring can be removed and replaced when necessary by removing a side stop, *i*, which closes the seat of said spring.

In connection with this gripe-hook coupling I use a device for uncoupling it from the top of the car, consisting of a push-plate, *j*, fitted in a slot in the side of the draw-head opposite to the bearing-springs, and connected by pivot *k* to an outside link, *l*, pivoted to the side of the draw-head, extending beyond the end of the car, and connected to a link, *m*, which connects with the lower end of a hand-lever, *n*, pivoted to the end of the car, and, passing through a notched locking-plate, *r*, extends above the car-top, so as to operate the push-plate *j* to uncouple the cars as they are slackened up by pressing the hook end back against the springs and out of line with the coupling-pin, as shown in Fig. 4.

The locking-plate *r* is notched or has a suitable stop, so as to hold the lever with the

push-plate in coupled or uncoupled position—that is, when the cars are coupled the push-plate of the cars will be drawn out, and by shifting the lever as the cars slacken their speed the hook end is pushed out of line with and clear of the pin.

In coupling the cars the rounded hook end passes into the draw-head between the coupling-pin and the side springs, and, compressing the latter, catches over the pin.

It matters not which car the hook is in, so it is placed to hook against the side springs.

I claim—

1. The car-coupling consisting of the gripe-hook *a*, the springs *f g h* at one side of each draw-head, and the coupling-pins *d e*, all having the relation to each other and adapted for use as shown and described.

2. The combination, with the gripe-hook and the bearing-spring *f* therefor, of the re-enforcing-springs *g h*, arranged in relation to the hook as shown and described.

3. The combination, with the gripe-hook, the springs *f g h*, and the coupling-pins *d e*, arranged as described, of the push-plate *j* and its connecting hand-lever *n*, all constructed and arranged for use as shown and described.

In testimony whereof I have hereunto set my hand in the presence of three witnesses.

NATHANIEL F. BRENT.

Witnesses:

JAMES N. CASTLE,

J. S. WHEELER,

IRA W. CASTLE.