

12

EUROPEAN PATENT APPLICATION

21 Application number: **87101544.2**

51 Int. Cl.4: **B 65 D 41/04**

22 Date of filing: **05.02.87**

30 Priority: **06.02.86 JP 16231/86 U**

71 Applicant: **Kao Corporation, 1-14-10, Nihonbashi Kayaba-cho, Chuo-ku Tokyo (JP)**

43 Date of publication of application: **19.08.87 Bulletin 87/34**

72 Inventor: **Yoshiro, Fumihiko, 1414 - 78 Azeyoshi, Ageo-shi Saitama-ken (JP)**

84 Designated Contracting States: **BE DE ES FR GB IT**

74 Representative: **Patentanwälte Grünecker, Kinkeldey, Stockmair & Partner, Maximilianstrasse 58, D-8000 München 22 (DE)**

54 **Container.**

57 A container has a container main body and a cap member threadedly engageable with a neck portion of the container main body. The container of the present invention is characterized in that at least one of male and female screws threadedly engaged with each other is formed as such that the width of a screw groove becomes gradually smaller as it goes toward the terminal end direction of the screw, and a pressure flank and a clearance flank of the male and female screws are contacted each other under pressure at a portion where the width of the screw groove is small at the end of screwing operation. Contrary to the prior art, since the container according to the present invention is constructed as such that the screws as a whole are gradually brought to be contacted under pressure according to advancement of the screwing operation, the container main body and cap member can be surely sealed.

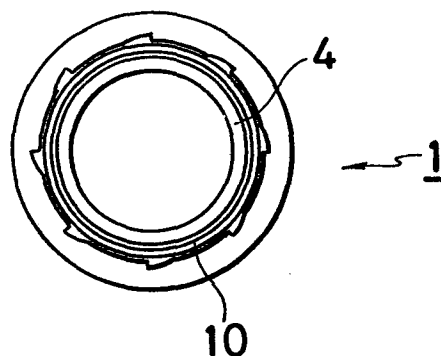

EP 0 232 856 A2

CONTAINER

BACKGROUND OF THE INVENTION

(1) Field of the Invention

This invention relates to a container of the type in that a neck portion of a container main body is threadedly engaged with a cap member, and more particularly to a container, in which the threaded engagement between the container main body and the cap member is prevented from becoming loose.

(2) Description of the Prior Art

Known devices for preventing the loosening of a cap member from a container main body are disclosed, for example, in Japanese utility model publication No.56-42187, Japanese utility model publication No.56-48057, Japanese utility model publication No.57-9239, Japanese utility model publication No.59-42342, Japanese utility model early laid-open publication No.55-145459 and Japanese utility model early laid-open publication No. 57-88750.

The prior art disclosed in the above-mentioned publications will be described hereunder.

Japanese utility model publication No.56-42187 discloses a loosening prevention device in which a number of projections for pressing the terminal end portion of a female screw are vertically spacedly

arranged on a lower edge of the terminal end portion of a male screw.

Similarly, Japanese utility model publication No. 56-48057 discloses a loosening prevention device in which a male screw is built up at its terminal end portion along its upper edge and spaces between adjacent screw threads are formed gradually narrower.

Similarly, Japanese utility model publication No. 57-9239 discloses a loosening prevention device in which a screw thread having a lead angle 0° at the terminal end portion of a male screw, and this screw thread is made higher than other screw threads.

Similarly, Japanese utility model publication No. 59-42342 discloses a loosening prevention device in which a step portion is provided at the terminal end portion of a screw thread, which continuously extends in such a manner as to fill root threads between screw threads.

Similarly, Japanese utility model early laid-open publication No.55-145459 discloses a loosening prevention device in which the width of a screw thread is formed large at a terminal end portion of a male screw, a screw groove between adjacent screw threads is formed narrow.

Similarly, Japanese utility model early laid-open publication No.57-88750 discloses a manual-operated

spray container in which a check knob is formed on a thread line of a male screw.

However, the above-described prior art has the following problems.

Regarding the device disclosed in Japanese utility model publication No.56-42187, the projections are readily worn or broken due to a number of repeated opening and closing operations and a loosening is readily taken place due to shock.

Regarding the device disclosed in Japanese utility model publication No.56-48057, Japanese utility model publication No.57-9239, Japanese early laid-open publication No.55-145459 or Japanese utility model early laid-open publication No.57-88750, when a lifting-up motion is applied to a cap member in the mid-way or toward the end of the screwing operation thereof, it happens that the cap member is tightened in the mid-way (in the state that the container is not yet completely sealed) of the screwing operation. Moreover, since the tightening is achieved only at the terminal end portion of the screw in order to prevent a loosening to occur, a loosening is readily taken place due to shock.

Regarding the device disclosed in Japanese utility model publication No.59-42342, same as the device disclosed in the Japanese utility model publication No.

56-48057, when such motion as to push and spread the cap side wall in the mid-way or toward the end of tightening operation of the cap member is applied, a tightening is readily taken place even in the midway (in the state that the container is not yet completely sealed) of the screwing operation. Moreover, since the tightening is achieved only at the terminal end portion of the screw in order to prevent a loosening to occur, a loosening is readily taken place due to shock.

SUMMARY OF THE INVENTION

It is therefore an object of the present invention to provide a container, wherein a loosening of the engagement between a container main body and a cap member can be prevented and, at the same time, incomplete sealing can be prevented by means of gradual engagement under pressure by whole screws instead of a rapid engagement of the screws under pressure toward the end (the terminal end portion of the screw) of the screwing operation.

In order to achieve the above object, there is essentially provided a container having a container main body and a cap member threadedly engagable with a neck portion of the container main body characterized in that at least one of male and female screws (internal and external threads) threadedly engaged with

each other is formed as such that the width of a screw groove becomes gradually smaller as it goes toward the terminal end direction of the screw, and a pressure flank and a clearance flank of the male and female screws are contacted each other under pressure at a portion where the width of the screw groove is small at the end of a screwing operation.

The manner in which the present invention achieves these objects, and other inherent therein, will become more apparant to those skilled in the art as the description proceeds and as reference is made to the accompanying drawings, in which like reference numerals indicate corresponding parts throughout.

BRIEF DESCRIPTION OF THE DRAWINGS

Fig. 1 is a plan view of an important portion of a container main body of a container according to one embodiment of the present invention;

Fig. 2 is a side view of the above;

Fig. 3 is an enlarged side view, partly cut out, of a cap member according to one embodiment of the present invention;

Fig. 4 is a bottom view of the enlarged portion of the cap member;

Fig. 5 is an enlarged vertical sectional view showing the cap member threadedly engaged with the container main body of the container according to one

embodiment of the invention;

Fig. 6 is a side view of an important portion of a container main body of a container according to another embodiment of the present invention;

Fig. 7 is an enlarged sectional view similar to Fig. 5 of the another embodiment of the present invention;

Fig. 8 is a side view of an important portion of a container main body of a container according to a further embodiment of the present invention;

Fig. 9 is a side view of an important portion of a container main body of a container according to a still further embodiment of the present invention; and

Fig. 10 is a side view, partly cut out, of an important portion of an yet further embodiment of the present invention.

DETAILED DESCRIPTION OF THE EMBODIMENT

One preferred embodiment of a container according to the present invention will be described hereinafter with reference to the accompanying drawings.

Fig. 1 through 5 illustrate one embodiment of the present invention. In these figures, 1 denotes a container main body and 2 denotes a cap member. The container main body 1 is formed around a neck portion 3 with a male screw 4. On the other hand, the cap

member 2 is formed at its inner surface with a female screw 5 for threadedly engaging with the male screw 4. Both the male and female screws 4 and 5 are of buttless threads. The female screw 5, like common female screws, is formed as such that the width of thread ridge, the width of the screw groove and the pitch of the screws are constant.

The male screw 4 is formed as such that the widths A_1 , A_2 of the screw grooves become gradually smaller as it goes toward the terminal end direction of the screw ($A_1 > A_2$) and not only pressure flanks 6, 7 of the male and female screws 4, 5 but also clearance flanks 8, 9 are contacted under pressure at a portion where the width of the screw groove is small when the threading engagement between the male and female screws is almost finished. Since the male screw 4 is formed as such that the configuration of the thread ridge is constant but, as described in the foregoing, the width of the screw groove becomes gradually smaller as it goes toward the terminal end direction of the screw, the pitch of the thread becomes gradually smaller as it goes toward the terminal end direction of the screw.

In Figs. 1 through 5, 10 denotes a neck ring (ratchet structure for preventing a loosening to occur) provided at the outer peripheral portion of a basic portion (lower end portion) of the neck portion 3 of

the container main body 1. 11 denotes an inner ring (ratchet structure for preventing a loosening to occur) provided at the inner peripheral portion of a lower end portion of the cap member 2 in such a manner as to correspond to the neck ring 10. 12 denotes a contact ring provided on the ceiling portion of the cap member 2 in such a manner as to be vertically hung down from the ceiling portion and adapted to ensure a sealing between the cap member 2 and the container main body 1. 13 denotes a projection vertically formed on the outer peripheral portion of the cap member 2 and adapted to serve for threadedly engaging the cap member 2 with the container main body 1.

In the early stage of the screwing operation of the cap member 2 onto the container main body 1 in the container shown in Figs. 1 through 5, the screwing operation can be easily started just as same as the case with the conventional one since the starting end portion of the male screw 4 on the container main body 1 and the starting end portion of the female screw 5 are formed same as the conventional male and female screws. When the screwing operation is further advanced, as described the width of the screw groove of the male screw 4 of the container main body 1 is formed in such a manner as to become gradually smaller as it goes toward the terminal end portion, while the female

screw 5 of the cap member 2 is not formed as such as mentioned but formed same as that of a usual female screw. Due to the foregoing, the space between the clearance flank 9 at the starting end portion of the female screw 5 and the clearance flank 8 of the male screw 4 becomes gradually narrower, and the clearance flanks 8, 9 of the male and female screws 4, 5 are also caused to be contacted under pressure at the end of the screwing operation as the pressure flanks 6, 7 are. Finally, these are completely contacted under pressure as shown in Fig. 5, thereby to prevent an occurrence of a loosening of the cap member 2 from the container main body 1 with sure. And, simultaneously with the contact under pressure, the contact ring 12 of the cap member 2 is surely contacted under pressure with the top portion of the neck portion of the container main body 1, and the neck ring 10 of the container main body 1 is brought to be engagement with the inner ring 11 of the cap member 2. Accordingly, the sealing between the container main body 1 and the cap member 2 can be further ensured and a occurrence of the loosening of the cap member 2 from the container main body 1 can be more surely prevented.

The container main body 1 and the cap member 2 are preferably molded of a thermoplastic synthetic resin material having somewhat elasticity such as poly-

propylene, polyethylene, etc. However, the materials of the container main body 1 and the cap member 2 are not limited to the above. The container main body 1 and the cap member 2 are molded of such thermoplastic synthetic resin material because the width of the screw groove at the terminal end portion of the male screw 4 is made smaller than the width of the thread ridge at the terminal end portion of the female screw 5 (the space between the clearance flanks 8, 9 is set minus at the terminal end portions of the male and female screws 4, 5) and the fastening can be achieved in the wider range than the prior art, thereby to more effectively prevent at occurrence of the loosening of the cap member caused by shock.

Figs. 6 and 7 illustrate another embodiment of the present invention.

The container of this embodiment has the same structure as that of the container shown in Figs. 1 through 5 except that the configuration of the male screw 4 of the container main body 1 is modified and that the neck ring 10 and inner ring 11 are not provided. More specifically, the male screw 4 of this embodiment is formed as such that, as with the embodiment of Figs. 1 through 5, the widths A_1 , A_2 of the screw grooves are formed in such a manner as to become gradually smaller ($A_1 > A_2$) as it goes toward

the terminal end portions of the screws. In order to obtain such screw grooves as mentioned, contrary to the embodiment of Figs. 1 through 5, the pitch B_1 of the clearance flank is made smaller than the pitch B_2 of the pressure flank ($B_2 > B_1$) and the widths C_1, C_2, C_3 of the thread ridges are formed in such a manner as to become gradually larger ($C_1 < C_2 < C_3$) as it goes toward the terminal end portion of the screws. The dotted line of Fig. 6 shows the conventional, commonly-used male screw 4.

Fig. 8 illustrates a further embodiment of the present invention.

The container of this embodiment is formed as such that the terminal end portion of the thread ridge of the male screw 4 of the container main body 1 of the embodiment shown in Figs. 1 through 5 is provided with step portions 14, 14 which are disposed in symmetric relation with respect to the central axis of the male screw 4 and continuously extending by partly filling the space between the screw threads (making the screw groove portion thick in wall), and at the end of the screwing operation, the thread ridge of a female screw (not shown) of the cap member is brought to be contacted under pressure with the step portions 14, 14, thereby to more effectively prevent an occurrence of the loosening of the cap member from the container main

body 1.

Fig. 9 illustrates a still further embodiment of the present invention.

The container of this embodiment is formed as such that the terminal end portion of the thread ridge of the male screw 4 of the container main body 1 according to the embodiment of Figs. 6 and 7 are vertically spacedly provided at its lower and upper edges with a number of projections 15, 15... and at the end of the screwing operation, the thread ridge of a female screw (not shown) of the cap member is brought to be in point-contact with the projections 15, 15..., thereby to more effectively prevent an occurrence of the loosening of the cap member from the container main body 1.

Fig. 10 illustrates a yet further embodiment of the present invention.

The container according to this embodiment is formed as such that a trigger type sprayer 16 is detachably threadedly engaged with the container main body 1 through the cap member 2. In general, regarding a container provided with a trigger type sprayer 16, vibrations are readily taken place when the trigger type sprayer is operated and the cap member 2 is tended to be loosened. However, since the width of the screw groove is formed in such a manner as to become

gradually smaller as it goes toward the terminal end portion of the screw in this embodiment same as the case with the afore-mentioned embodiments, the cap member 2 is not loosened.

Although a container of the present invention has been described in the forms of various embodiments, the present invention is not limited to these embodiments. For example, the male screw 4 of the container main body 1 may be formed of a commonly-used male screw, and the width of the screw groove of the female screw 5 may be formed in such a manner as to become gradually smaller as it goes toward the terminal end portion of the screw, or otherwise the widths of the screw grooves of both the male and female screws may be formed in such a manner as to become gradually smaller as it goes toward the terminal end portions of the screws. Further, contrary to the embodiments, the screw around the neck portion 3 of the container main body 1 may be formed of a female screw, and the screw around the cap member 2 may be formed of a male screw. Furthermore, by appropriately changing the combinations of the embodiments, the embodiment of Figs. 1 through 5 may be provided with the projections 15, 15, 15 of Fig. 9, or otherwise the embodiment of Figs. 6 and 7 may be provided with the step portions 14, 14 of Fig. 8. Furthermore, the male and female screws 4, 5 may be

formed of multiple thread screws.

As described in the foregoing, in the conventional container, it often happened that torque became suddenly large at the end of the screwing operation of the cap member with respect to the container main body and the fastening is taken place in the state that the top end of the neck portion of the container main body and the contact ring of the cap member were not contacted under pressure. On the contrary, the container according to the present invention is constructed as such that the screws as a whole are gradually brought to be contacted under pressure according to advancement of the screwing operation. Accordingly, the container main body and cap member can be surely sealed.

Furthermore, in the container according to the present invention, the container main body and cap member are formed of a thermoplastic synthetic resin material having somewhat elasticity. Accordingly, the fastening can be achieved in the wider range than the prior art utilizing elastic deformation of screw, thereby to prevent an occurrence of the loosening of the cap member caused by shock.

WHAT IS CLAIMED IS:

1. A container having a container main body and a cap member threadedly engagement with a neck portion of the container main body characterized in that at least one of male and female screws threadedly engaged with each other is formed as such that the width of a screw groove becomes gradually smaller as it goes toward the terminal end direction of the screw, and a pressure flank and a clearance flank of the male and female screws are contacted each other under pressure at a portion where the width of the screw groove is small at the end of screwing operation.

2. A container as claimed in claim 1, wherein said screw is of a buttless thread.

3. A container as claimed in claim 1, wherein the width of the screw groove of the male screw becomes gradually smaller as it goes toward the terminal end direction of the screw.

4. A container as claimed in claim 1, wherein the configuration of a thread ridge is constant while a pitch of the thread becomes gradually smaller as it goes toward the terminal end direction of the screw by forming the screw groove as such that the width thereof becomes gradually smaller as it goes toward the terminal end direction of the screw.

5. A container as claimed in claim 1, wherein the width of the screw groove becomes gradually smaller as it goes toward the terminal end direction of the screw by making a pitch of the clearance flank smaller than that of the pressure flank and forming the thread ridge as such that the width thereof becomes gradually larger as it goes toward the terminal end direction of the screw.

6. A container as claimed in claim 1, wherein a trigger type sprayer is detachably threadedly attached to said container main body through said cap member.

1/5

FIG. 1

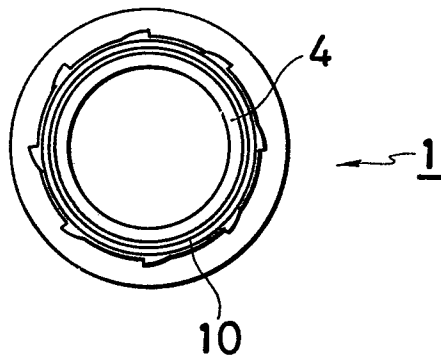
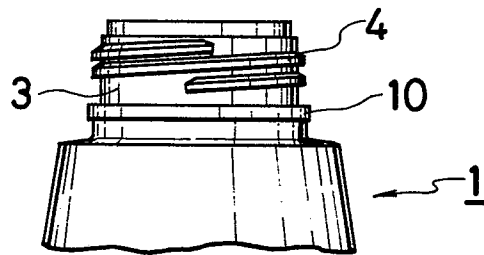

FIG. 2



2/5

FIG. 3

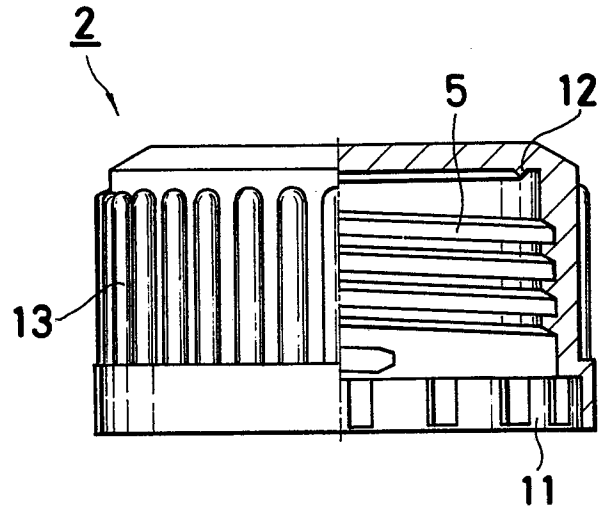

FIG. 4

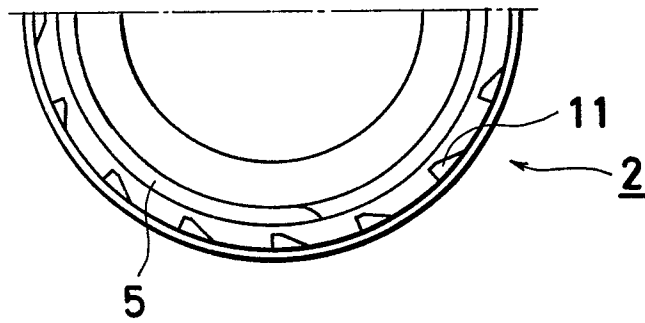
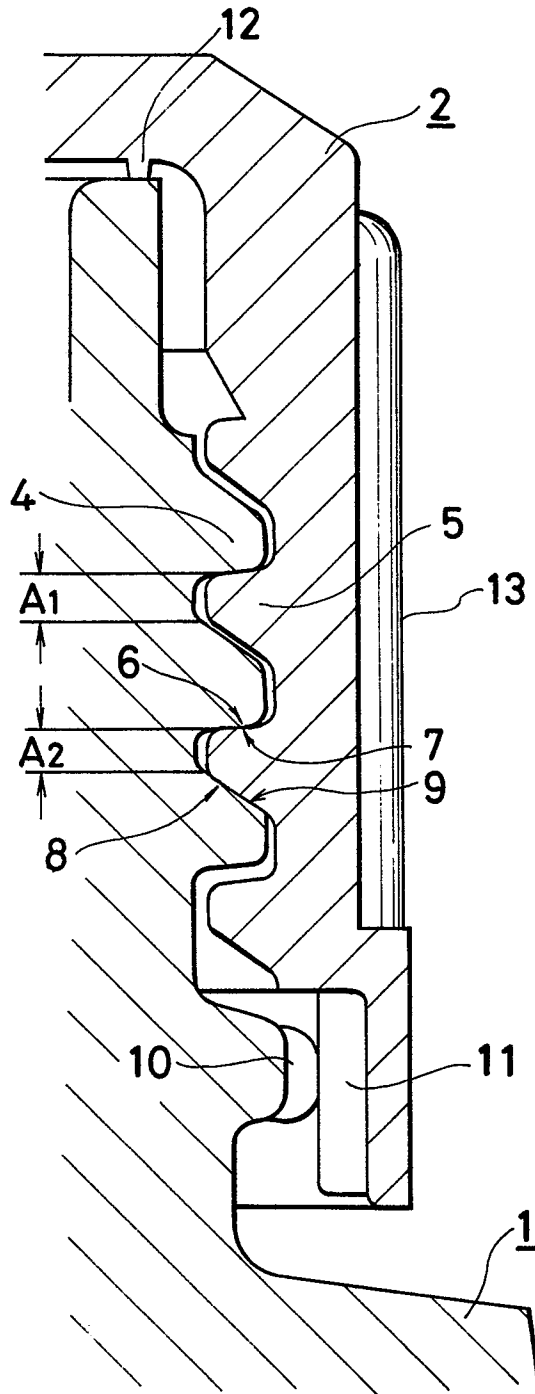

FIG. 5



4/5

FIG. 6

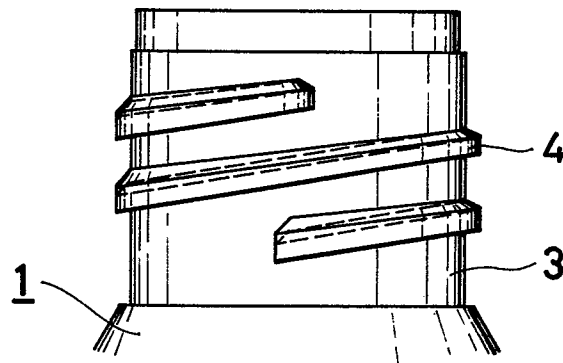
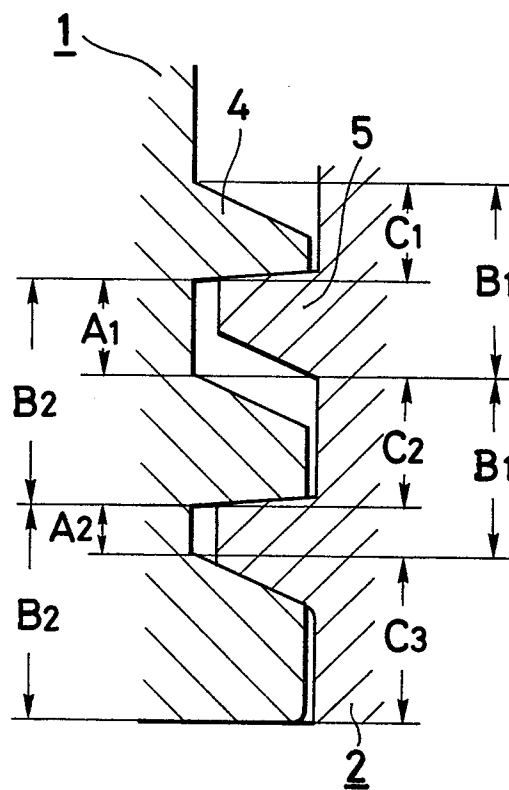

FIG. 7



5/5

FIG. 8

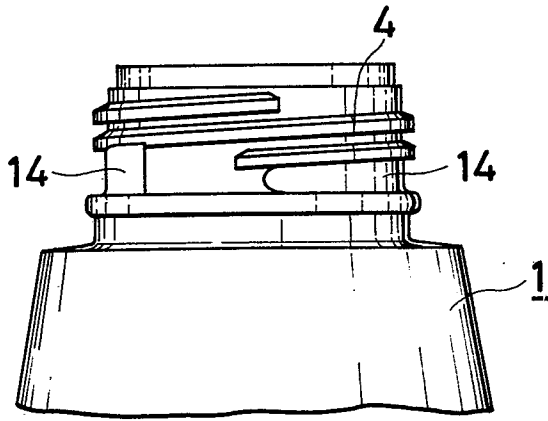

FIG. 9

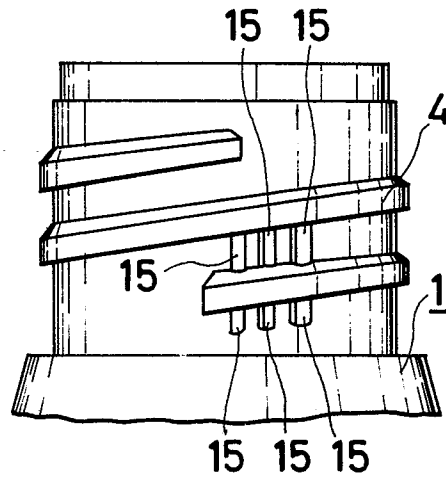

FIG. 10

