



US 20180014624A1

(19) **United States**

(12) **Patent Application Publication** (10) **Pub. No.: US 2018/0014624 A1**
PRADE et al. (43) **Pub. Date: Jan. 18, 2018**

(54) **DEVICE FOR PACKAGING AND APPLYING EYELINER**

(30) **Foreign Application Priority Data**

Dec. 2, 2014 (FR) 1461797

(71) Applicant: **L'OREAL**, Paris (FR)

Publication Classification

(72) Inventors: **Pauline PRADE**, Clichy (FR); **Alexis LEONARD**, Clichy (FR)

(51) **Int. Cl.**
A45D 34/04 (2006.01)

(52) **U.S. Cl.**
CPC *A45D 34/04* (2013.01); *A45D 2200/1072* (2013.01)

(73) Assignee: **L'OREAL**, Paris (FR)

(21) Appl. No.: **15/532,584**

(57) **ABSTRACT**

(22) PCT Filed: **Dec. 2, 2015**

Device for packaging and applying eyeliner, including: a container containing the eyeliner to be applied, an applicator tip for applying the eyeliner contained in the container, having two opposite main facets, with a variable width that passes through a maximum, the two facets converging in the direction of the distal end of the applicator tip.

(86) PCT No.: **PCT/EP2015/078377**

§ 371 (c)(1),

(2) Date: **Jun. 2, 2017**

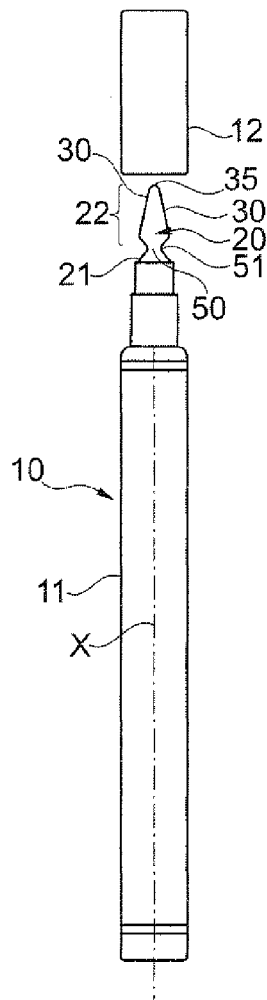

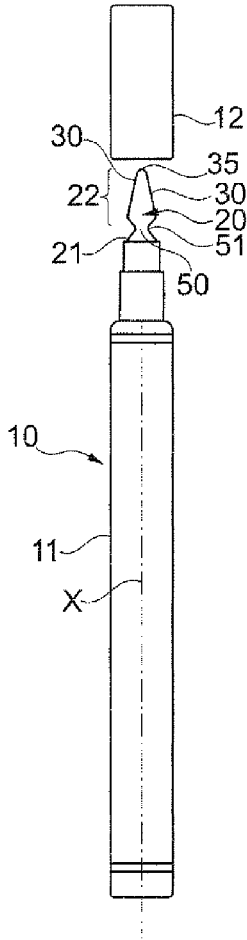

Fig. 1

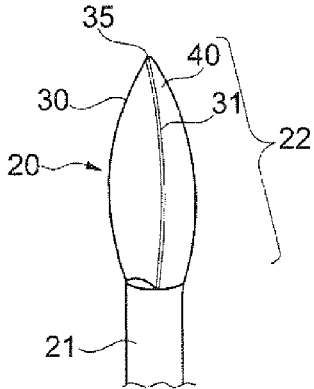

Fig. 2

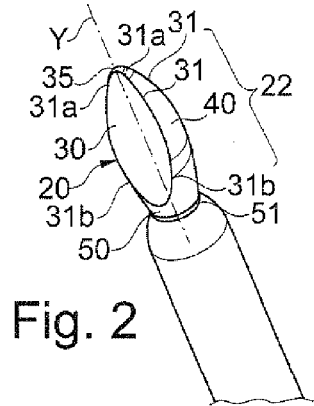

Fig. 3

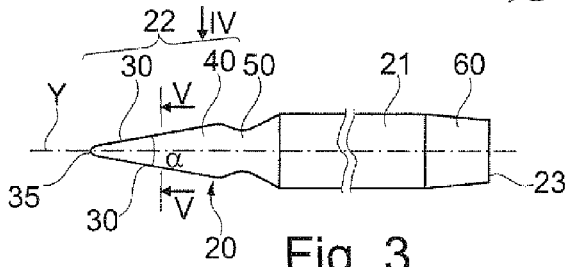

Fig. 4

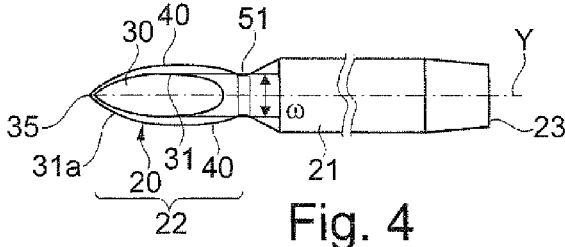

Fig. 5

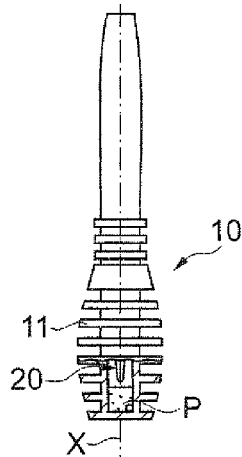

Fig. 6

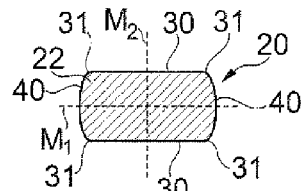

Fig. 7

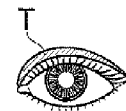

Fig. 8

DEVICE FOR PACKAGING AND APPLYING EYELINER

[0001] The present invention relates to devices for packaging and applying eyeliner.

[0002] It is known practice to make up the eyelid or the eyebrows by drawing a line of eyeliner with the aid of an applicator provided to this end.

[0003] Among known eyeliner applicators, some comprise a container provided with a threaded neck on which there can be fixed a closure cap which carries a stem provided at its end with an applicator tip that is generally produced by injection-moulding thermoplastic material with a flocked coating. A wiping member is usually positioned in the neck in order to wipe off the stem and reduce the quantity of product taken when the applicator is withdrawn.

[0004] FR 2933281 describes an eyeliner applicator comprising a stem and an applicator end piece that is carried by the stem, is able to deform during use and makes it possible, depending on the orientation selected, to draw two lines with different thicknesses.

[0005] FR 2 836 031 discloses an eyeliner applicator having at least two tips.

[0006] FR 2 793 663 discloses various applicators intended for applying a product to the lips, said applicators being used with a container provided with a wiping member. The shape of the applicator member is chosen so as to obtain differentiated wiping thereof, with a region of the applicator member that is more heavily laden with product.

[0007] Also known are applicator pens comprising an applicator tip produced by machining a felt.

[0008] There is a benefit to allowing the user to vary the thickness of the line drawn on the eyelids or eyebrows.

[0009] The invention aims to meet this need and achieves this by proposing a device for packaging and applying eyeliner, comprising:

[0010] a container containing the eyeliner to be applied,

[0011] an applicator tip for applying the eyeliner contained in the container, having two opposite main facets, preferably with an elongate contour, with a variable width that passes through a maximum, the two facets converging in the direction of the distal end of the applicator tip.

[0012] By virtue of the invention, the user can easily vary the width of the line during application, depending on the result to be achieved, by bringing that portion of the applicator tip that has the desired width into contact with the skin, while moving the applicator over the skin.

[0013] The applicator tip is preferably made of felt, that is to say it comprises fibres that are oriented longitudinally and bonded together. The product may thus diffuse by capillary action within the applicator tip on account of its porosity. It is possible for the applicator tip to be flocked or not to be flocked.

[0014] The fibres may be fibres made of thermoplastic material, in particular acrylic polymer, polyester or polyamide. The fibres may have a linear density of less than 1 denier, preferably between 0.5 and 0.9 denier, in particular 0.7 denier (or around 9 micrometers). The fibres may be made of Nylon®.

[0015] As a variant, the applicator tip is moulded from plastics material.

[0016] It is possible for the applicator tip not to have any perforations, or cavities or indentations in its surface used for application.

[0017] It is thus possible for the applicator tip not to have any outwardly concave ridge at its end, or any striations or grooves. It is possible for the applicator tip only to have surfaces that are convex towards the outside, in the region of the applicator part that comes into contact with the skin during makeup application.

[0018] The main facets may each have a contour tending towards oval, or even an oval contour.

[0019] The main facets may be connected by side facets that each have a convex shape in cross section. These side facets may each have a convex shape in longitudinal section.

[0020] The convex shape makes application to the skin easier.

[0021] The applicator tip may be symmetrical with respect to a first median plane of symmetry that passes between the two main facets.

[0022] The applicator tip may be symmetrical with respect to a second plane of symmetry that intersects the two main facets mid-way across their width.

[0023] A symmetrical shape makes it possible to make up the right eye or the left eye in an identical manner.

[0024] The main facets may have a radius of curvature greater than 4 mm, better still greater than 10 mm, in longitudinal section.

[0025] The main facets may be portions of cylinders of revolution, with a generatrix perpendicular to the longitudinal axis of the applicator tip.

[0026] The side facets may have distal portions that converge towards the distal end of the applicator tip and proximal portions that converge towards the proximal end of the applicator tip.

[0027] The user can use the side facets to apply the eyeliner.

[0028] The side facets may have a variable width that passes through a maximum, the maximum being preferably closer from the proximal end than from the distal end of the applicator. The side facets allow the user to easily vary the line during application, depending on the result to be achieved.

[0029] It is preferable that the maximum width of the side facets is smaller than the maximum width of the main facets. Thus the user can draw a thinner line with the side facets than with the main facets.

[0030] When one of the main facets is view face-on, the side-face of the side facets is convex. The radius of curvature at the middle of the side facets may be less than 20 mm, better, less than 15 mm. With such a curvature, the user can bring a portion of one of the side facets that has a desired width into contact with the skin, while moving the applicator over the skin.

[0031] The applicator tip may have a narrowing of its cross section between an applicator part and an end piece for mounting the applicator tip in the body of an applicator pen or in the stem of an applicator.

[0032] The distal end of the applicator tip is preferably situated on the longitudinal axis of the applicator tip, said longitudinal axis being rectilinear.

[0033] A further subject of the invention is a method for making up the eyelid or the eyebrows, comprising the step of applying eyeliner to the skin with the aid of an applicator according to the invention.

[0034] Further features and advantages of the present invention will become apparent from reading the following

detailed description of nonlimiting illustrative embodiments thereof and from examining the appended drawing, in which:

[0035] FIG. 1 shows a schematic elevation view of an example of a packaging and application device according to the invention, in the form of an applicator pen,

[0036] FIG. 2 shows a perspective view of the applicator tip of the pen from FIG. 1 on its own,

[0037] FIG. 3 is a side view of the applicator tip from FIG. 2,

[0038] FIG. 4 is a face-on view along IV in FIG. 3,

[0039] FIG. 5 is a cross section on V-V in FIG. 3,

[0040] FIG. 6 shows a variant applicator tip according to the invention,

[0041] FIG. 7 shows a variant packaging and application device, and

[0042] FIG. 8 illustrates an example of the makeup result that can be obtained with the invention.

[0043] The packaging and application device 10 shown in FIG. 1 is in the form of an applicator pen comprising a body 11 with an elongate shape along an axis X, which defines a reservoir containing the makeup product to be applied, in this case eyeliner. The latter contains for example water, pigments, in particular iron oxide, colorants and polymers.

[0044] The capacity of the reservoir is for example between 1 and 6 ml.

[0045] The device 10 may also comprise, as illustrated, a closure cap 12 which is fixed on the body 11 for example by snap-fastening, screwing or friction.

[0046] The body 11 bears an applicator tip 20 according to the invention, shown on its own in FIGS. 2 to 5, which may be fixed to the body 11 by any suitable means and which is for example force-fitted into a corresponding housing provided at the upper end of the body 11, communicating with the reservoir.

[0047] This tip 20 is preferably made of felt.

[0048] The tip 20 has a mounting end piece 21 which serves to fix it to the body 11, and an applicator part 22 which serves for application by coming into contact with the skin in order to deposit thereon eyeliner which impregnates the felt.

[0049] The end piece 21 may have a bevelled proximal part 60.

[0050] The applicator tip 20 is elongate along a longitudinal axis Y which is coincident with the longitudinal axis X of the body 11 of the device 10.

[0051] The applicator tip 20 is fed with product through its proximal end 23 and the product can diffuse longitudinally in the end piece, along the axis Y, until it reaches the applicator part 22 intended to come into contact with the skin.

[0052] The end piece 21 has a rotationally symmetrical shape about the axis Y, with a circular section. The largest diameter of the end piece 21 is for example between 4 and 6 mm and is for example 5 mm.

[0053] The applicator part 22 has two opposite main facets 30 which each have, in face-on view, an elongate, in particular oval, contour delimited by a ridge 31.

[0054] In the example in FIGS. 2 to 5, the facets 30 are very slightly domed towards the outside, with a radius of curvature r of for example between 4 and 100 mm, the surface of the facets 30 being for example a portion of a cylinder of revolution, with a generatrix perpendicular to the axis Y. As a variant, the facets 30 are flat or concave.

[0055] As can be seen in particular in FIG. 5, the applicator part 22 preferably has a symmetrical shape with respect to a first median plane M1, situated between the facets 30, and with respect to a second median plane M2, perpendicular to the first.

[0056] Each facet 30 is delimited at the front by regions 31a of the ridges 31 that converge towards the distal end 35 of the applicator tip 20, and at the rear by regions 31b that converge towards the proximal end 23.

[0057] The length L of each facet 30 is for example between 3 and 15 mm, better still between 5 and 10 mm, and its width w is between 0.3 and 8 mm.

[0058] The facets 30 are connected together by side facets 40 that are generally convex towards the outside, being both domed towards the outside when the applicator part 22 is seen in longitudinal section and domed towards the outside when the applicator part is seen in cross section, as in FIG. 5. When the applicator part 22 is seen in longitudinal section, the radius of curvature q at the middle of the side facets 30 is less than 15 mm.

[0059] The side facets 40 have a variable width that passes through a maximum 41. The maximum 41 is closer from the proximal end of the applicator than of the distal end of the applicator.

[0060] The angle α at which the front regions of the facets 30 converge towards the distal end 35 is generally between 3 and 80°.

[0061] The applicator part 22 is connected to the end piece 21 by an intermediate portion 50 that defines a narrowing 51. The latter gives the applicator tip flexibility. At the narrowing, the cross section of the applicator tip is for example circular, as illustrated.

[0062] A variant applicator tip 20 is shown in FIG. 6. In this variant, the facets 30 are less wide than in the example in FIGS. 2 to 5, and the ridges 31 run from the distal end 35, where they meet, to the end piece 21.

[0063] In face-on view, the front region of each facet 30 or 40 is approximately triangular.

[0064] In the example in FIG. 7, the applicator tip is mounted at the end of a stem of an applicator which can be fixed to the body 11 of the container containing the product P.

[0065] During use, as illustrated in FIG. 8, the user can draw a line T of eyeliner that is more or less thick depending on whether the applicator tip 20 is moved in a direction parallel to the median plane M₁, with contact between a side face 40 and the skin, or whether a larger portion of the applicator part 22 comes into contact with the skin, by way of a main facet 30, the applicator tip then being moved parallel to the plane M₂.

[0066] The invention is not limited to the examples that have just been described. In particular, it is possible to further modify the shape of the applicator tip without departing from the scope of the present invention. The applicator tip can be produced by moulding an elastomer, and then covering it with a flocked coating.

[0067] The expression “comprising a” should be understood as being synonymous with “comprising at least one”.

1. Device for packaging and applying eyeliner, comprising:

- a container containing the eyeliner to be applied,
- an applicator tip for applying the eyeliner contained in the container, having two opposite main facets, with a

variable width that passes through a maximum, the two facets converging in the direction of the distal end of the applicator tip.

2. Device according to claim 1, wherein the facets each have an elongate contour.

3. Device according to either of claim 1, wherein the facets are connected by side facets that each have a convex shape in cross section.

4. Device according to claim 3, wherein the side facets each have a convex shape in longitudinal section.

5. Device according to claim 1, wherein the applicator tip is symmetrical with respect to a first median plane of symmetry that passes between the two main facets.

6. Device according to claim 1, wherein the applicator tip is symmetrical with respect to a second plane of symmetry that intersects the two main facets mid-way across their width.

7. Device according to claim 1, wherein the main facets have a radius of curvature greater than 4 mm in longitudinal section.

8. Device according to claim 1, wherein the main facets are portions of cylinders of revolution, with a generatrix

perpendicular to the longitudinal axis of the applicator tip, or, as a variant, flat or concave faces.

9. Device according to claim 1, claims, wherein the side facets have distal portions that converge towards the distal end of the applicator tip and proximal portions that converge towards the proximal end of the applicator tip.

10. Device according to claim 1, claims, wherein the applicator tip has a narrowing of its cross section between an applicator part and an end piece for mounting the applicator tip in the body of an applicator pen or in the stem of an applicator.

11. Device according to claim 1, wherein the applicator tip is made of felt that is or is not flocked.

12. Device according to claim 1, wherein the distal end of the applicator tip is situated on the longitudinal axis of the applicator tip, said longitudinal axis being rectilinear.

13. Method for making up the eyelid, comprising the step of applying a line of eyeliner with the aid of a device as defined in claim 1.

* * * * *