



US 20210054629A1

(19) **United States**

(12) **Patent Application Publication**

**Kladt Sobrino**

(10) **Pub. No.: US 2021/0054629 A1**

(43) **Pub. Date: Feb. 25, 2021**

(54) **ROOFING SYSTEM WITH MODULAR TILES**

(52) **U.S. Cl.**

(71) Applicant: **Juan Eduardo Kladt Sobrino**,  
Scottsdale, AZ (US)

(72) Inventor: **Juan Eduardo Kladt Sobrino**,  
Scottsdale, AZ (US)

CPC ..... **E04D 1/12** (2013.01); **E04B 1/2403**  
(2013.01); **E04D 1/34** (2013.01); **E04D**  
**2001/3494** (2013.01); **E04B 2001/249**  
(2013.01); **E04D 2001/345** (2013.01); **E04D**  
**2001/347** (2013.01); **E04B 2001/2493**  
(2013.01)

(21) Appl. No.: **16/998,370**

(57) **ABSTRACT**

(22) Filed: **Aug. 20, 2020**

**Related U.S. Application Data**

(60) Provisional application No. 63/019,184, filed on May 1, 2020, provisional application No. 62/889,284, filed on Aug. 20, 2019.

**Publication Classification**

(51) **Int. Cl.**  
**E04D 1/12** (2006.01)  
**E04B 1/24** (2006.01)  
**E04D 1/34** (2006.01)

A roofing system for forming a roof includes a plurality of tiles. Each tile has a frame at a perimeter of the tile, and the frame includes an upstream element, an opposed downstream element, and opposed first and second side elements, thereby bounding a central panel area. Each tile further includes a side trim, a batten, and a ridge cap. When the tiles, side trim, batten, and ridge cap are arranged to form a roof, the batten is secured at a lower edge of the roof and directed upward to receive the downstream elements of the tiles, the side trim is secured at a side edge of the roof and directed laterally to receive one of the first and second side elements of the tiles, and the ridge cap is secured at a ridge of the roof and directed downward to lap over the upstream elements of the tiles.

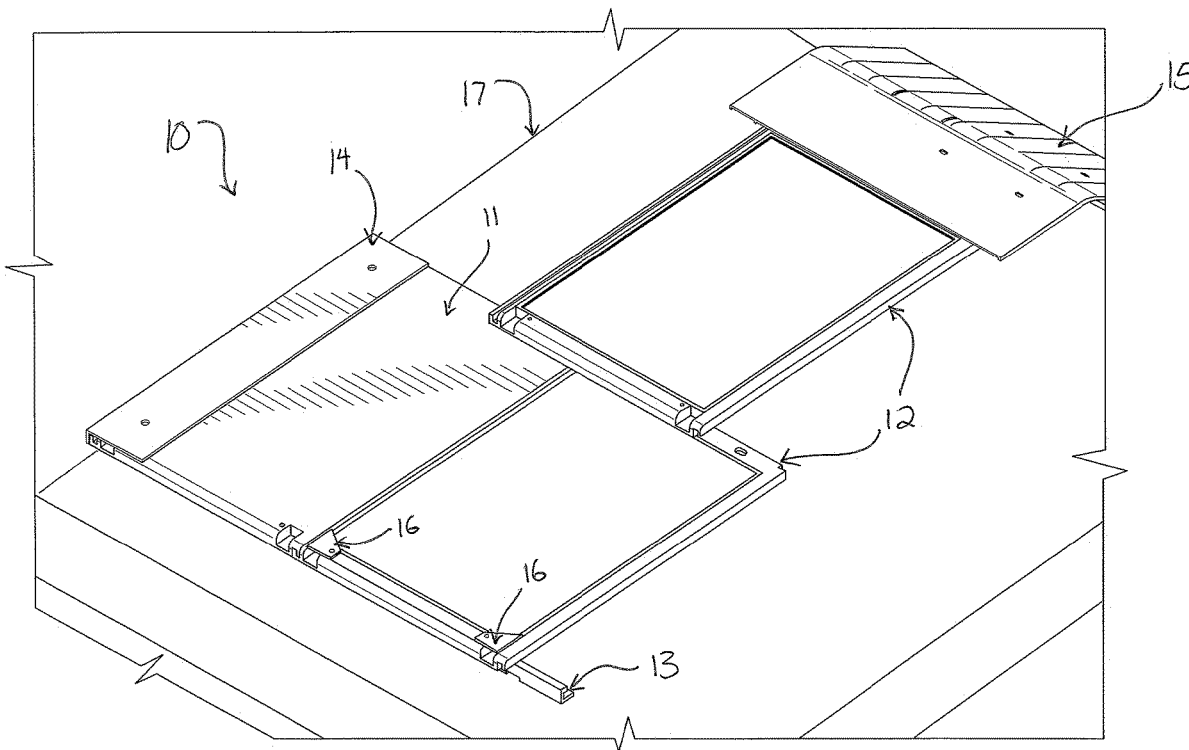

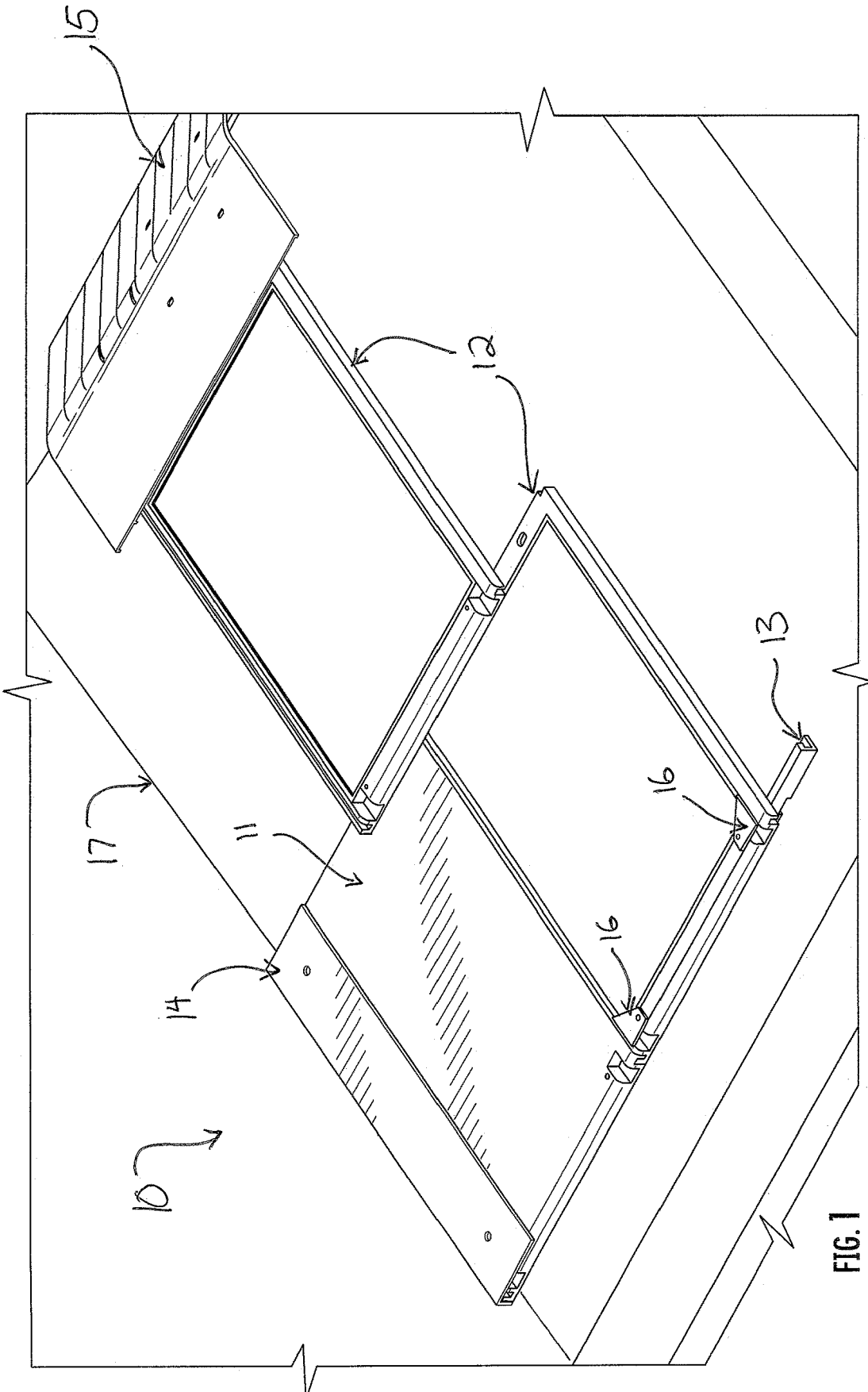
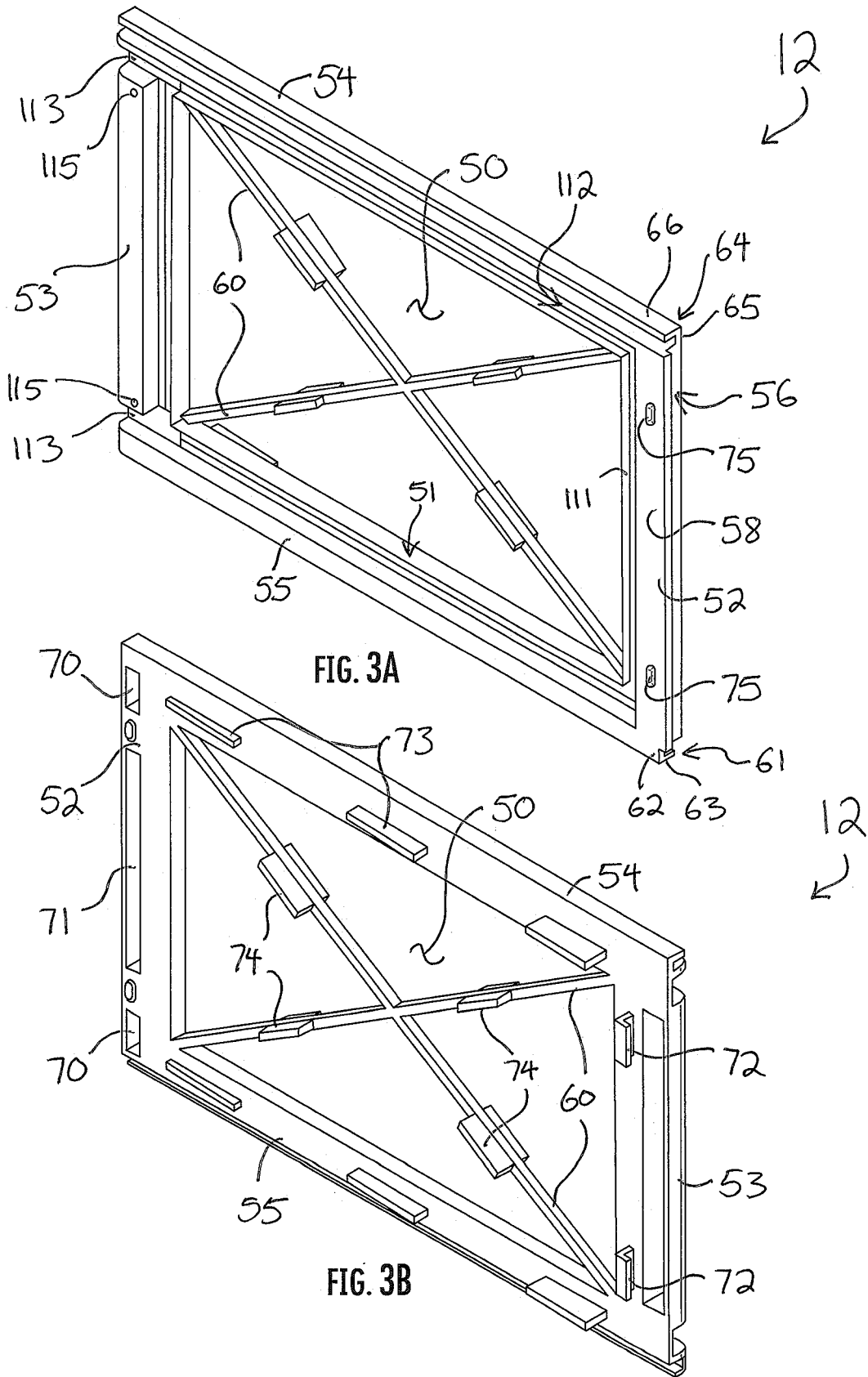
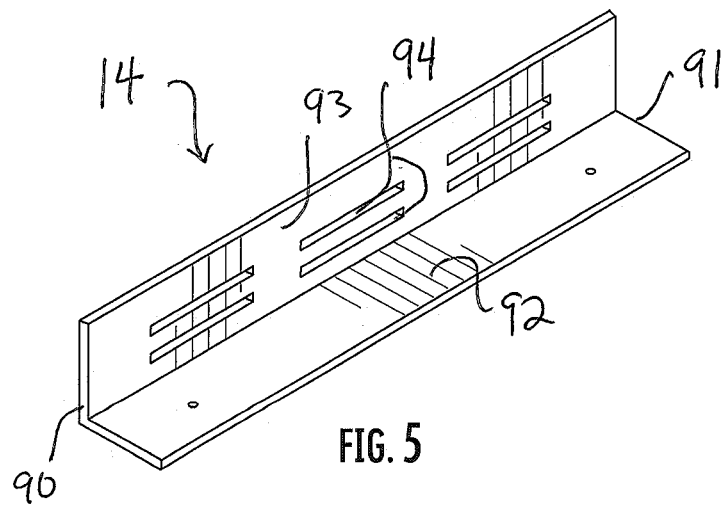
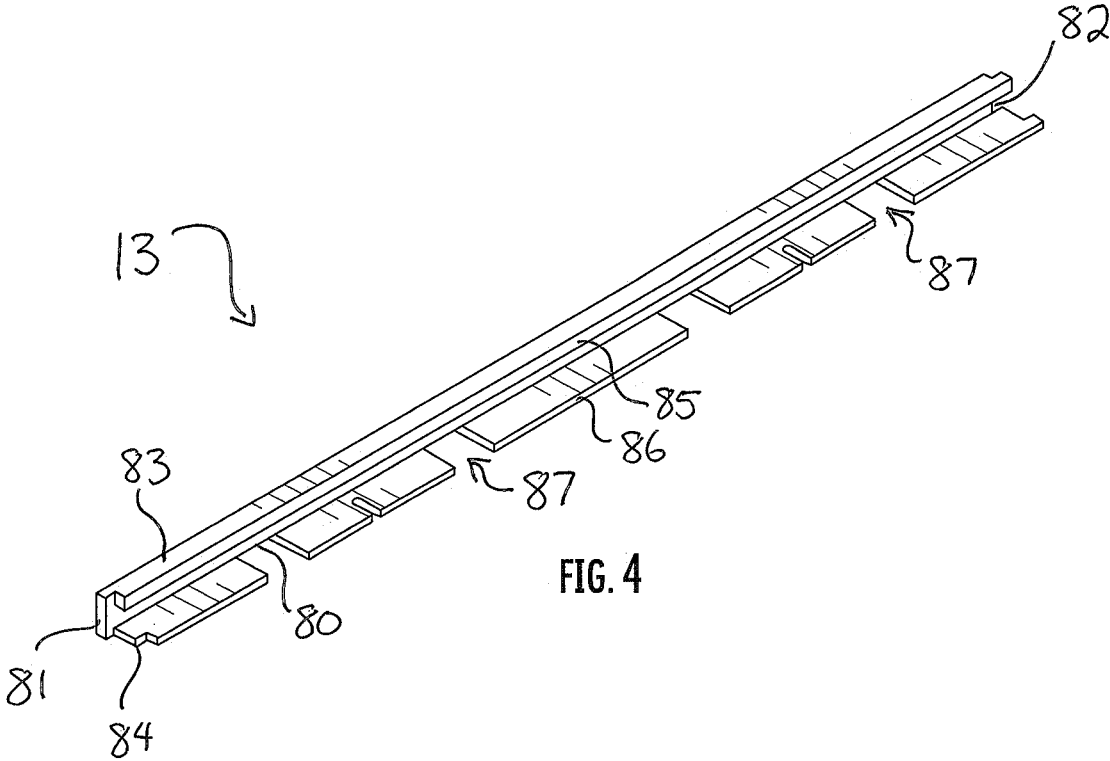

FIG. 1







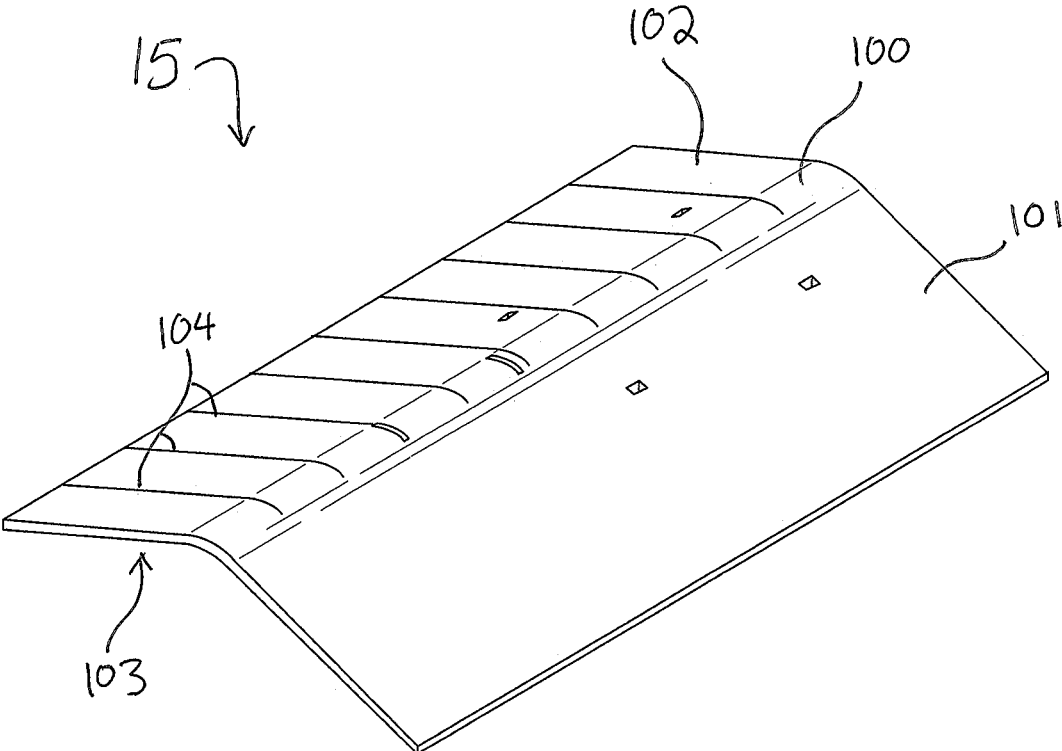
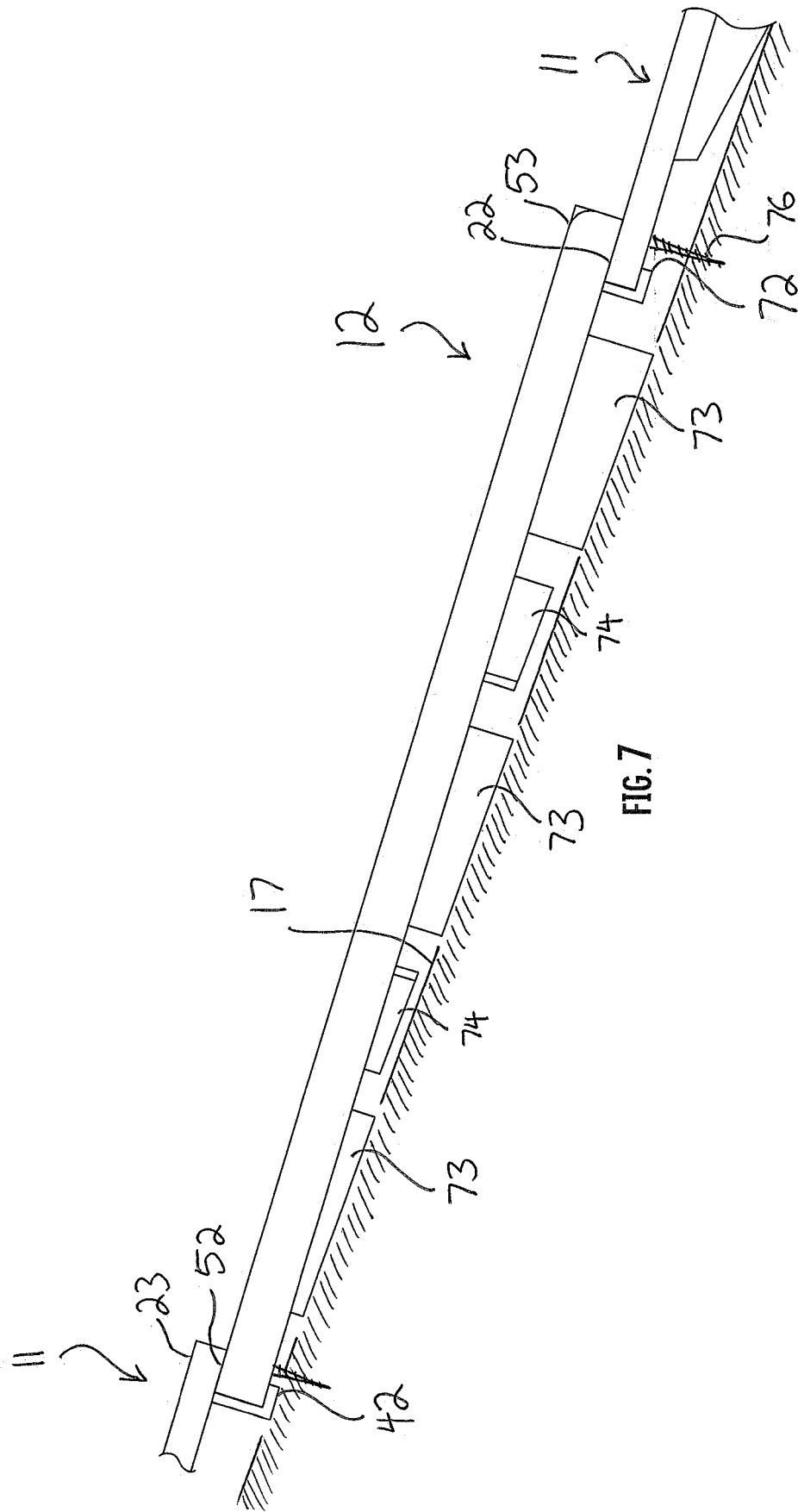

FIG. 6



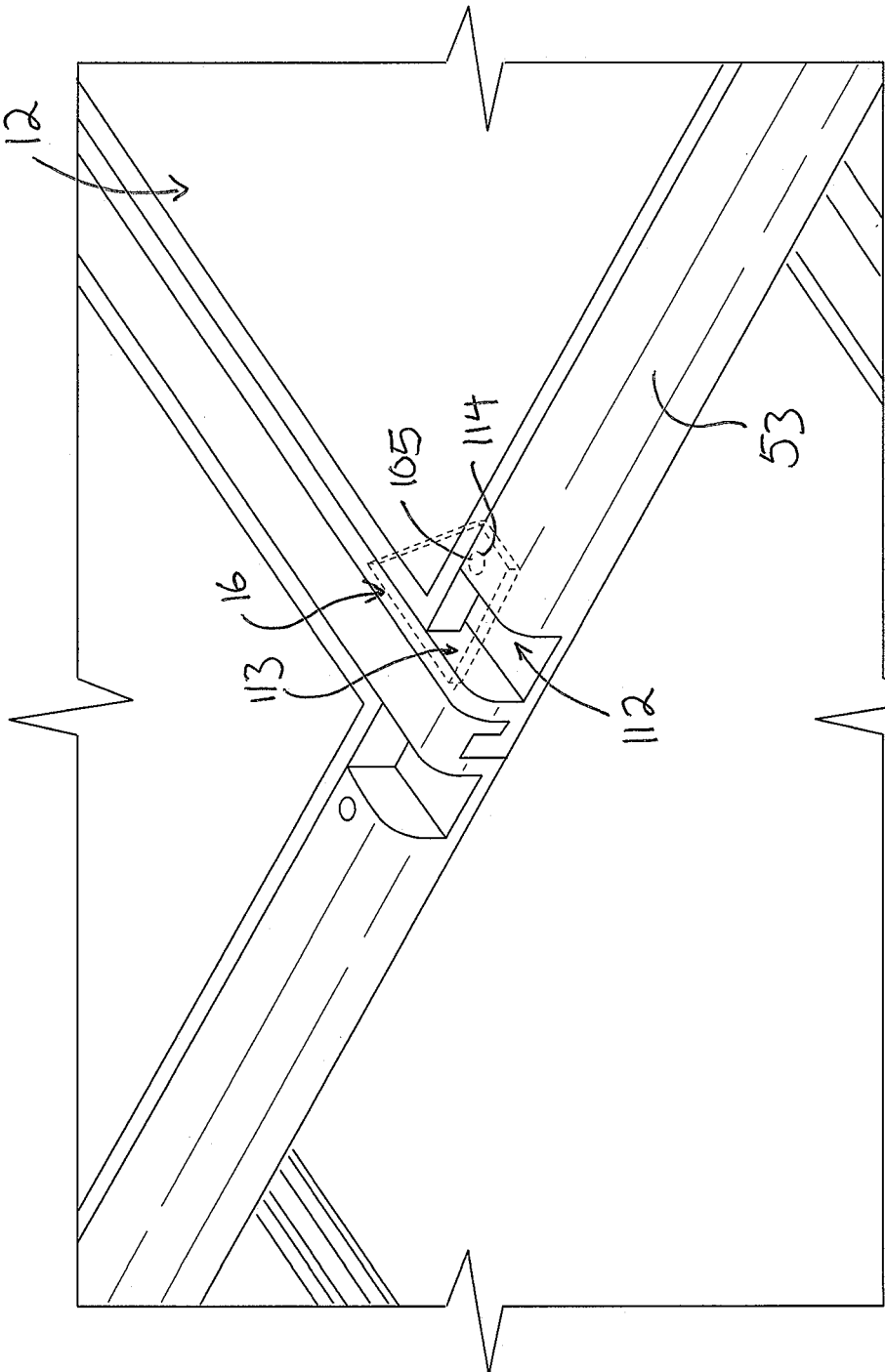
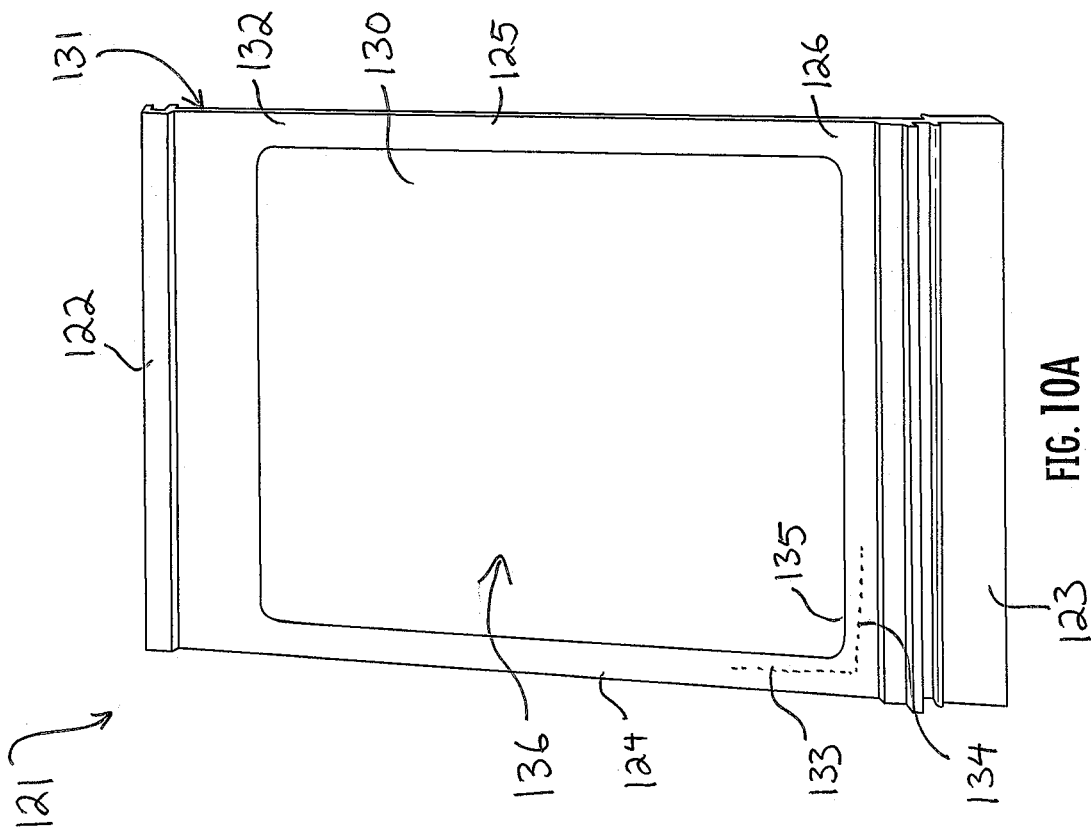
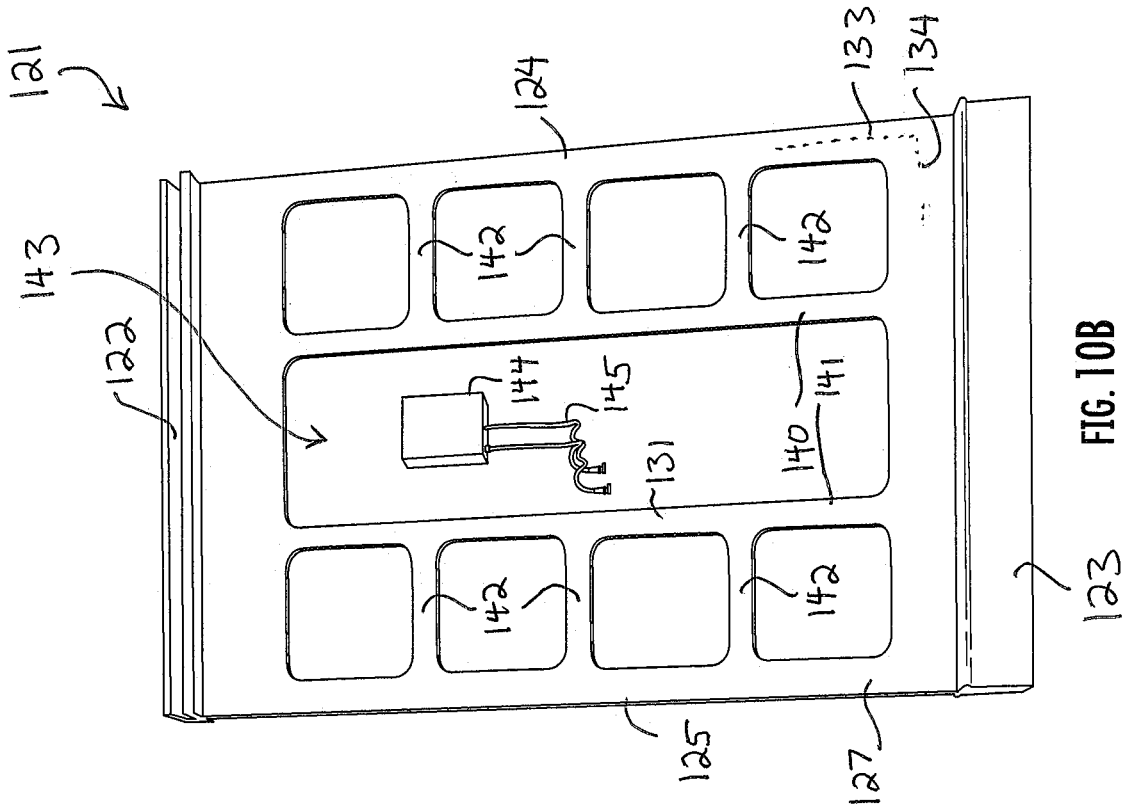

FIG. 8





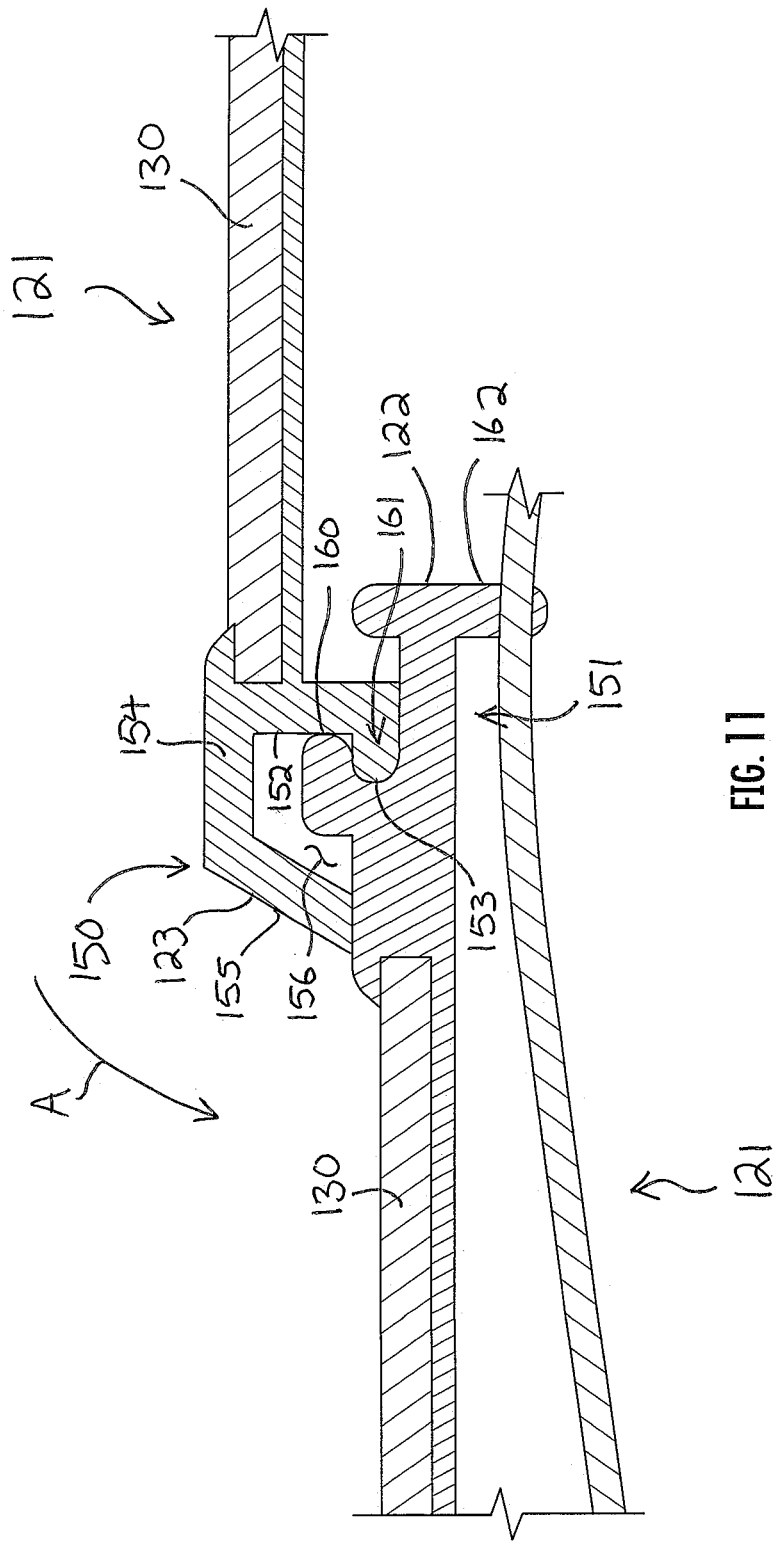
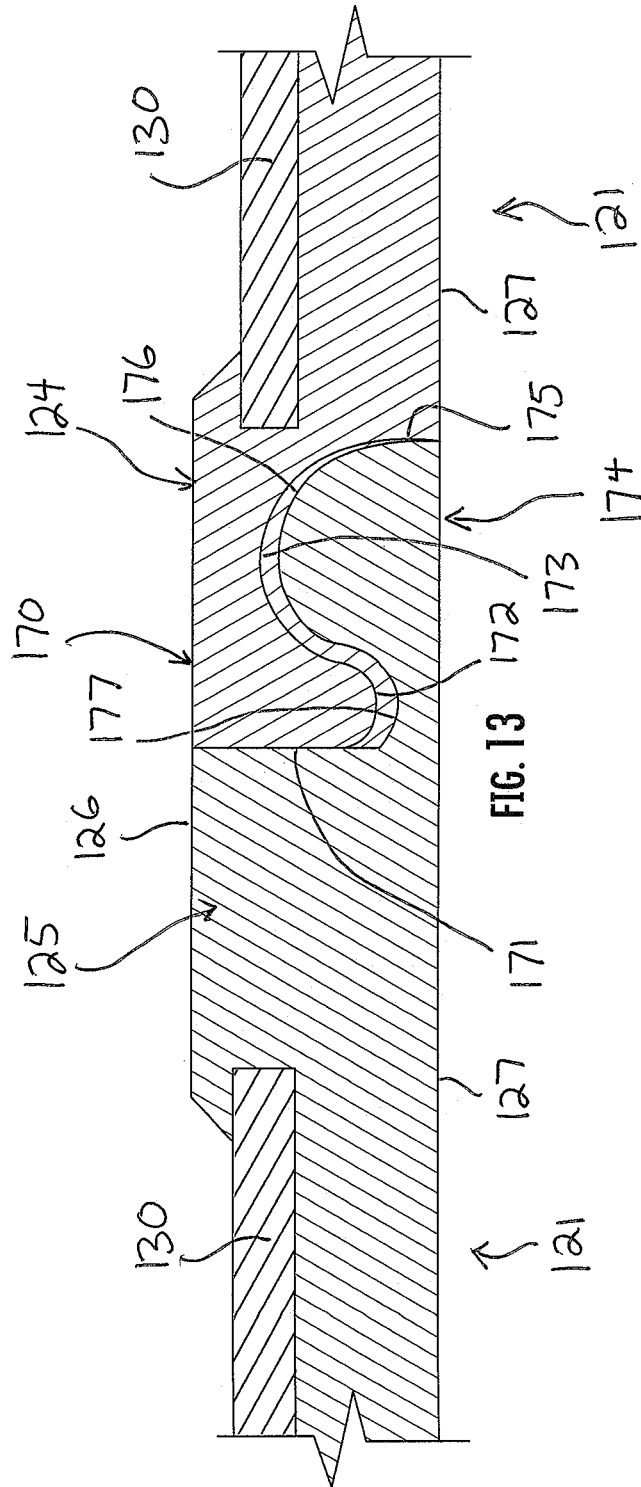

FIG. 11





## ROOFING SYSTEM WITH MODULAR TILES

### CROSS-REFERENCE TO RELATED APPLICATIONS

[0001] This application claims the benefit of U.S. Provisional Application No. 62/889,284, filed Aug. 20, 2019, and also claims the benefit of U.S. Provisional Application No. 63/019,184, filed May 1, 2020, both of which are hereby incorporated by reference.

### FIELD

[0002] The present invention relates generally to construction, and more particularly to roof construction.

### BACKGROUND

[0003] Roofs, and roofing tiles, constitute a heavy static load on all buildings. Roofs are meant to protect the building and its occupants from weather, temperature, wind, insects, animals, and other hazards. However, buildings must be built especially strong to support the weight of their own roofs. Shingles can be lightweight, but in areas such as the southwest United States, roofing materials such as Spanish-style concrete tiles are heavy, weighing as much as five to fifteen pounds each.

[0004] In the sunbelt, many homes and commercial buildings have photovoltaic or solar panels mounted to their roofs to capture solar energy during the day. These panels represent an additional static load, as they require roof penetrations, mounts, rails, and electrical equipment, including the panels themselves. Installing solar panels often involves a roof replacement; once the panels are in place, roof maintenance becomes difficult, and so many homeowners choose to repair or replace their roof at the same time they install solar panels. This process creates a great deal of waste and inefficiency. An improved way to mount solar panels is needed.

### SUMMARY

[0005] A roofing system for forming a roof includes a plurality of tiles. Each tile has a frame at a perimeter of the tile, and the frame includes an upstream element, an opposed downstream element, and opposed first and second side elements, thereby bounding a central panel area. Each tile further includes a side trim, a batten, and a ridge cap. When the tiles, side trim, batten, and ridge cap are arranged to form a roof, the batten is secured at a lower edge of the roof and directed upward to receive the downstream elements of the tiles, the side trim is secured at a side edge of the roof and directed laterally to receive one of the first and second side elements of the tiles, and the ridge cap is secured at a ridge of the roof and directed downward to lap over the upstream elements of the tiles.

[0006] The above provides the reader with a very brief summary of some embodiments described below. Simplifications and omissions are made, and the summary is not intended to limit or define in any way the disclosure. Rather, this brief summary merely introduces the reader to some aspects of some embodiments in preparation for the detailed description that follows.

### BRIEF DESCRIPTION OF THE DRAWINGS

[0007] Referring to the drawings:

[0008] FIG. 1 is a perspective view of an exemplary arrangement of an embodiment of a roofing system including solid and photovoltaic panel tiles secured by a batten, side trim, ridge cap, and clamps;

[0009] FIGS. 2A and 2B are bottom and top perspective views, respectively, of the solid tile of FIG. 1;

[0010] FIGS. 3A and 3B are top and bottom perspective views, respectively, of the photovoltaic panel tile of FIG. 1;

[0011] FIGS. 4, 5, and 6 perspective views of the batten, side trim, and ridge cap, respectively, of FIG. 1;

[0012] FIG. 7 is a side elevation of the photovoltaic panel tile;

[0013] FIG. 8 is an enlarged view of downstream elements of two adjacent tiles, illustrating a channel for channeling water off the roofing system;

[0014] FIG. 9 is a perspective view of an exemplary arrangement of an embodiment of a roofing system including a plurality of roof tiles;

[0015] FIGS. 10A and 10B are front and rear perspective views of the one of the tiles of FIG. 9;

[0016] FIG. 11 is a section view taken along the line 11-11 in FIG. 9, showing an engagement assembly between upstream and downstream tiles;

[0017] FIG. 12 is a section view showing an alternate engagement assembly between upstream and downstream tiles; and

[0018] FIG. 13 is a section view taken along the line 13-13 showing an engagement assembly between adjacent tiles.

### DETAILED DESCRIPTION

[0019] Reference now is made to the drawings, in which the same reference characters are used throughout the different figures to designate the same elements. Briefly, the embodiments presented herein are preferred exemplary embodiments and are not intended to limit the scope, applicability, or configuration of all possible embodiments, but rather to provide an enabling description for all possible embodiments within the scope and spirit of the specification. Description of these preferred embodiments is generally made with the use of verbs such as “is” and “are” rather than “may,” “could,” “includes,” “comprises,” and the like, because the description is made with reference to the drawings presented. One having ordinary skill in the art will understand that changes may be made in the structure, arrangement, number, and function of elements and features without departing from the scope and spirit of the specification. Further, the description may omit certain information which is readily known to one having ordinary skill in the art to prevent crowding the description with detail which is not necessary for enablement. Indeed, the diction used herein is meant to be readable and informational rather than to delineate and limit the specification; therefore, the scope and spirit of the specification should not be limited by the following description and its language choices.

[0020] FIG. 1 is a top perspective view of a portion of a roofing system 10. The roofing system 10 is constructed over and covers a roof support structure 17 (such as beams, joists, trusses, etc.) below the roofing system 10, shielding it from rain, hail, snow, wind, sun, and other environmental elements, and includes a plurality of tiles 11 and 12 covering the roof support structure 17 as well as a locking batten 13, a side trim 14, a ridge cap 15, and clamps 16. The tiles 11 are solid panel tiles 11, and the other tiles are open tiles 12, hereinafter referred to as photovoltaic (“PV”) panel tiles 12,

which carry and support photovoltaic panels **110**. The tiles **11** are arranged in an interlocking array with each other to form a water-impermeable cover for the roof support structure **17**. The array of tiles **11** channels water from the upper or upstream end of the roofing system **10**, by the ridge cap **15**, down to the lower or downstream end of the roofing system **10**, toward the batten **13**. Briefly, the terminology “upper” or “upstream” and “lower” or “downstream” is generally used in this context to refer to or identify locations, elements, or relative arrangements which are closer to the ridge cap **15** (near the top of the roof) and to the batten **13** (near the bottom of the roof), respectively. Together with hardware, the batten **13**, the side trim **14**, and the ridge cap **15** cooperate to hold the array of tiles **11** and **12** in place, preventing it from moving laterally.

**[0021]** The two types of tiles discussed below with respect to this embodiments—the solid tile **11** and the photovoltaic panel tile **12**—are modular and thus interchangeable within the roofing system **10**. As such, discussion will sometimes be made with reference to “a tile,” or “the tile,” or “the tile **11**,” or “the tile **12**.” With the explanation that either tile **11** or **12** may be used in the roofing system, the user should understand that reference to “a tile,” or “the tile,” or “the tile **11**,” or “the tile **12**” is not likely limited to one of the tiles but is used merely for clarity of the explanation. The context should inform whether the discussion relates only to one of the tiles **11** or **12**.

**[0022]** FIG. 1 shows an exemplary roofing system **10** only; only four tiles **11** are shown in a cross layout; there are significant gaps in this roof. However, FIG. 1 is intended to merely display the constituent elements of the roofing system **10** and not to model an actual roof. Obviously, most roof support structures **17** will have a more conventional shape, such as a rectangle or triangle. In such cases, the roofing system **10** will adopt a corresponding conventional shape, with the tiles **11** being arranged to construct an array that covers that shape. Indeed, because the tiles **11** are modular, interlocking, and light, they can be easily moved and arranged to overlay roof support structures **17** of a wide variety of designs and layouts.

**[0023]** FIGS. 2A-3B illustrate the tiles **11** and **12**. Turning to FIGS. 2A and 2B first, the solid panel tile **11** (hereinafter, “tile **11**”) is shown in two perspectives to illustrate it from below (FIG. 2A) and above (FIG. 2B). The tile **11** is rectangular and includes a broad, solid panel **20** formed integrally and monolithically to a rectangular frame **21**. The rectangular frame **21** is disposed on the underside of the panel **20** such that the solid panel **20** seems to cover an entire top surface of the tile **11**. The frame **21** includes four linear members or elements arranged and coupled to each other in a rectangular shape: an upstream element **22**, an opposed downstream element **23**, and opposed first side and second side, or left and right, elements **24** and **25**. The frame **21** is most visible in the perspective of FIG. 2A. The elements **22-25** of the frame **21** are formed to each other such that they define a continuous perimeter **26** of the tile **11**. The elements **22-25** also bound and define a central panel area **27** of the tile **11**. In the solid tiles **11**, the solid panel **20** extends across the panel area **21**. Further, because it is formed integrally to the frame **21** and the constituent elements of the frame **21**, the panel **20** and elements **22-25** present a single, continuous, uninterrupted, and substantially smooth top surface **30** of the solid tile **11**.

**[0024]** Two diagonally-arranged spars **31** extend between the corners formed between the elements **22-25**. The spars **31** are thin, elongate, linear, and rigid structural members. They are formed integrally to the underside of the panel **20** and also to the elements **22-25** at the corners formed between them. These spars **31** provide structural support and rigidity to the panel **20** in the central panel area **27** between the frame elements **22-25**.

**[0025]** A rail **32** projects outward along the right element **25**, just offboard therefrom, parallel to the right element **25**. The rail **32** includes a flange **33**, proximate the right element **25** and extending outward from the right element **25** along the top surface **30** of the tile **11**, and a depending or downturned lip **34**, distal to the right element **25** and spaced apart therefrom by the flange **33**. The flange **33** and lip **34** define an engagement element of a side engagement assembly. When the tile **11** is arranged on the roof support structure **17**, the rail **32** is directed so that it opens downwardly, and so it defines a tongue portion of a tongue-and-groove engagement assembly.

**[0026]** The complementary engagement of that side engagement assembly is a groove, discussed in the paragraph below, formed on the other side of an adjacent tile **11** which snugly fits into that tile **11**. All solid tiles **11** are identical, however, and so reference will be made here simply to the same tile **11** illustrated in FIGS. 2A and 2B.

**[0027]** A rail **35** projects outward along the left element **24**, parallel to the left element **24**, and includes a flange **36** extending outward from the left element **24** along the bottom of the tile **11** and an upstanding lip **37**, distal to the left element **24** and spaced apart therefrom by the flange **36**. The flange **36** and lip **37** define the complementary engagement element of the side engagement assembly. The two complementary engagement elements fit together in a tongue-and-groove engagement, wherein the engagement element on the right element **25** side laps over and fits into the engagement element on the left element **24** side.

**[0028]** This side engagement assembly is suitable for engaging two tiles **11** (or two tiles **11** and **12**, or two tiles **12**) side-by-side. Preferably, the tiles **11** are stacked so that their upstream and downstream elements **22** and **23** are registered. In other words, their respective upstream elements **22** are aligned and their respective downstream elements **23** are aligned. In such a stacking, the full length of the engagement element on one tile **11** is fully engaged with the full length of the complementary engagement element on the adjacent tile **11**. Not only do these structures engage with each other, but they act as a primary channel to channel water off the tile **11**, too. The rail **32** on the right element **25** acts to collect water from the panel **20** and channel it down the tile **11**. When tiles **11** are placed directly above one another, the water will stream from one channel to the next, down the roofing system **10**, until it pours off the roof altogether.

**[0029]** On the underside of the upstream element **22** (best shown in FIG. 2A) there are rectangular recesses formed upward into the upstream element **22**: proximate the left and right elements **24** and **25** are two small, rectangular recesses **40**. These recesses **40** are blind hollows in the upstream element **22**. Preferably, they do not extend entirely through the tile and instead stop short of the top surface **30**. The recesses **40** have slight overhanging lips around the opening leading to the hollows. Between these two side recesses **40** is a wide central recess **41**. The central recess **41** extends nearly entirely between the side recesses **40** and also has an

opening with small overhanging lips extending into the hollow that defines the recess 41.

[0030] The underside of the downstream elements 23 also includes engagement elements. On the downstream element 23, there are two hooks or latches 42. These latches 42 have arms which extend downward from the downstream element 23 and lips which then extend forwardly, or downstream, from the arms. The height of these latches 42, or the distance between the forwardly-projecting lips and the underside of the downstream element 23, corresponds to or matches the height of the upstream element 22. When the tiles 11 are stacked vertically, one above the other, these latches 42 hook under the upstream element 22 of a tile 11 or 12 placed in a downstream location, as shown in FIG. 7. Two holes 45 are formed through the upstream element 22 of the tile 11 (FIG. 2B), and when the tiles 11 are stacked on the roof support structure 17, fasteners such as screws are applied to the holes 45 and into the roof support structure 17 to further secure the tile 11.

[0031] The tiles 11 may be stacked in a grid fashion in which the tiles 11 of each row are aligned with the tiles 11 in the rows above and below. In this arrangement, the latches 42 hook under the upstream element 22 of the single tile 11 directly below, so that the tile 11 above engages only with the tile 11 directly below. Alternatively, the tiles 11 may be stacked in an offset fashion in which the tiles 11 of one row are offset or mis-aligned with the tiles 11 in the rows above and/or below. In this arrangement, the left latch 42 hooks under the tile 11 below and to the left, and the right latch 42 hooks under the tile 11 below and to the right, so that the tile 11 above is engaged with both tiles 11 below it.

[0032] A plurality of risers under the tile 11 sets an incline for the tile 11. These risers include side risers 43 and diagonal risers 44. There are preferably three sets of side risers 43 on the undersides of the left and right elements 24 and 25; each set is identical on each side. On each side, there is a first lowest riser proximate the upstream element 22, a second middle-height riser between the upper and downstream elements 22 and 23, and a third highest riser proximate the downstream element 23. The risers 43 are rectangular supports, thin posts aligned along the side element, and each has a flat bottom which is mis-aligned from the bottom of the side element. In other words, the left and right elements 25 have flat bottoms, but each of the risers 43 has a flat bottom which is not parallel to the flat bottoms of the elements 24 and 25. Instead, the bottoms of the risers 43 are parallel to another line which is offset or transverse to the flat bottoms of the elements 24 and 25, though the bottoms of the risers 43 are all each parallel to and registered with each other.

[0033] The bottom of the lowest riser is close to the bottom of the element 24 or 25, the bottom of the middle-height riser is further from the bottom of the element 24 or 25, and the bottom of the highest riser, is furthest from the bottom of the element 24 or 25. In this way, when the tile 11 is placed on a flat surface, the tile 11 rises at an angle such that the downstream element 23 is higher than the upstream element 22. When oriented properly and placed on an angled roof, of course, the downstream element 23 is lower than the upstream element 22, but it is slightly further from the roof line than is the upstream element 22.

[0034] The diagonal risers 44 are disposed on the diagonal spars 31. Preferably, there are two diagonal risers 44 on each of the spars 31: a lower riser and a higher riser. The risers 44

are oriented along the spars 31 and, like the side risers 43, are thin rectangular supporting posts with flat bottoms which are mis-aligned with the bottom of the spars 31. While each spar 31 has a bottom surface that is flat and parallel to the panel 20, the diagonal risers 44 have bottoms which are slightly oblique to the flat bottom surface of the spar 31 but which are aligned and parallel to each other. In this way, the panel 20 is supported not just at the elements 22-25 of the frame 21 but also between those elements 22-25, in the central panel area 27 where the spars 31 are.

[0035] Turning now to FIGS. 3A and 3B, the PV panel tile (hereinafter, "tile 12") is shown in top perspective (FIG. 3A) and bottom perspective (FIG. 3B). The tile 12 is rectangular and includes a large rectangular opening in a central panel area 50 defined within a rectangular frame 51. The frame 51 includes four linear members or elements arranged and coupled to each other in a rectangular shape: an upstream element 52, an opposed downstream element 53, and opposed left and right elements 54 and 55. The elements 52-55 are formed to each other such that they define a continuous perimeter 56 of the tile 12 and a continuous top surface 58 of the tile 12. Two diagonally-arranged spars 60 extend between the corners formed between the elements 52-55. The spars 60 are thin, elongate, linear, and rigid structural members. They are formed integrally to the elements 52-55 at the corners formed between them. These spars 60 provide structural support to the photovoltaic panel 110 carried within the frame 51.

[0036] A rail 61 projects outward along the right element 55, just offboard therefrom, parallel to the right element 55. The rail 61 includes a flange 62, proximate the right element 55 and extending outward from the right element 55 at the top surface 58 of the tile 12, and a depending or downwardly-turned lip 63, distal to the right element 55 and spaced apart therefrom by the flange 62. The flange 62 and lip 63 define an engagement element of a side engagement assembly. When the tile 12 is arranged on the roof support structure 17, the rail 61 is directed so that it opens downwardly, and so that it defines a tongue portion of a tongue-and-groove engagement assembly.

[0037] The complementary engagement of that side engagement assembly is a groove formed on the other side of an adjacent tile 12 which snugly fits into that tile 12. All of the PV panel tiles are identical, however, and so reference will be made here simply to the same tile 12 illustrated in FIGS. 3A and 3B.

[0038] A rail 64 projects along the left element 54, parallel to it, and includes a flange 65 extending outward from the left element 54 along the bottom of the tile 12 and an upstanding lip 66, distal to the left element 54 and spaced apart therefrom by the flange 65. The flange 65 and lip 66 define the complementary engagement element of the side engagement assembly. The two complementary engagement elements fit together in a tongue-and-groove engagement, wherein the engagement element on the right element 55 laps over and fits into the engagement element on the left element 54.

[0039] As with the tile 11, this side engagement assembly is suitable for engaging two tiles 12 side-by-side. Of course, the side engagement assembly is also suitable for engaging solid tiles 11 and PV panel tiles 12; the engagement elements are complementary to each other, regardless of whether they are on the tile 11 or the tile 12. Preferably, the tiles 12 are stacked so that their upstream and downstream elements 52

and 53 are registered. In other words, their upstream elements 52 are aligned with each other and their downstream elements 53 are aligned with each other. In such a stacking, the full length of the engagement element on one tile 12 is fully engaged with the full length of the complementary engagement element on the adjacent tile 12. Not only do these structures engage with each other, but they channel water, too. The rail 61 on the right element 55 acts to collect water from a PV panel supported in an upstream tile 12 and channel it down to a downstream tile 12.

[0040] On the underside of the upstream element 52, there are rectangular recesses 70 formed upward into the upstream element 52. Proximate the left and right elements 54 and 55 are two small, rectangular recesses 70. These recesses 70 are hollows in the upstream element 52 and have slight overhanging lips around the openings leading into the recesses 70. Between these two side recesses 70 is a wide central recess 71. The central recess 71 extends nearly entirely between the side recesses 70 and also has an opening with small overhanging lips extending into the hollow that defines the recess 71.

[0041] The undersides of the upstream and downstream elements 52 and 53 also include engagement elements, to allow the tiles 12 to engage with tiles 12 above and below. On the downstream element 53 of the tile 12, there are two hooks or latches 72. These latches 72 are directed forwardly, or away from the upstream element 52. When the tiles 12 are stacked vertically, one above the other, these latches 72 hook under the upstream element 52 to engage one row of tiles 12 with another row. In this arrangement, the latches 72 hook under the upstream element 52 of the single tile 12 directly below, so that the tile 12 above engages only with the tile 12 directly below. Alternatively, the tiles 12 may be stacked in an offset fashion in which the tiles 12 of one row are offset or mis-aligned with the tiles 12 in the rows above and/or below. In this arrangement, the left latch 72 hooks under the tile 12 below and to the left, and the right latch 72 hooks under the tile 12 below and to the right, so that the tile 12 above is engaged with both tiles 12 below it.

[0042] Two holes 75 are formed through the upstream element 52 of the tile 12 (FIG. 3A), and when tiles 12 are stacked on the roof support structure 17, fasteners 76 (FIG. 7) such as screws are applied to the holes 75 and into the roof support structure 17 to further secure the tile 12.

[0043] A plurality of risers under the tile 12 sets an incline for the tile 12. These risers include side risers 73 and diagonal risers 74. The side risers 73 are on the undersides of the left and right elements 54 and 55 and are identical on both sides. On each side, there are preferably three side risers 73: a first, lowest riser proximate the upstream element 52, a second, middle-height riser between the upstream and downstream elements 52 and 53, and a third, highest riser proximate the downstream element 53. The risers 73 are rectangular supports, thin posts aligned along the elements 54 and 55, and each has a flat bottom which is mis-aligned from the bottom of the side elements 54 and 55. In other words, the left and right elements 54 and 55 have flat bottoms, but each of the risers 73 has a flat bottom which is not parallel to the flat bottoms of the elements 54 and 55. Instead, the bottoms of the risers 73 are parallel to another line which is offset or transverse to the flat bottoms of the elements 24 and 25, though the bottoms of the risers 73 are all each parallel to and registered with each other.

[0044] The bottom of the lowest riser is close to the bottom of the element 54 or 55 on which it is disposed, the bottom of the middle-height riser is further from the bottom of the element 54 or 55, and the bottom of the highest riser is furthest from the bottom of the element 54 or 55. In this way, when the tile 12 is placed on a flat surface, the tile 12 rises at an angle such that the downstream element 53 is higher than the upstream element 52. When oriented properly and placed on an angled roof, of course, the downstream element 53 is lower than the upstream element 52, but it is slightly further from the roof line than is the upstream element 52.

[0045] The diagonal risers 74 are disposed on the diagonal spars 60. Preferably, there are two diagonal risers 74—a low riser and a high riser—on each of the spars 60. The risers 73 are oriented along the spars 60 and, like the side risers 73, are thin rectangular posts with flat bottoms which are mis-aligned with the bottom of the spars 60. While each spar 60 has a bottom surface that is flat and parallel, the diagonal risers 74 have bottoms which are slightly oblique to the flat bottom surface of the spar 60 but which are aligned and parallel to each other. In this way, the PV panel 110 is supported not just at the frame's elements 52-55 but also between those elements 52-55, in the open central panel area 50 where the spars 60 are.

[0046] Turning to FIG. 4, which shows perspective, side elevation, rear elevation, and top plan views, the locking batten 13 is a slender, elongate channel having a solid back 80 extending between two opposed sides 81 and 82. The back 80 is flat and upstanding between a top 83 and bottom 84 of the batten 13. Projecting forwardly from the top 83 of the back 80 is a continuous upper lip 85 extending between the sides 81 and 82. The lip 85 terminates just inboard of the side 81 and terminates just outboard of the side 82. Similarly, a lower lip 86 projects forwardly from the bottom 84 of the back 80 as well. This lower lip 86 is discontinuous: along its length between the sides 81 and 82 are a number of gaps 87 which separate the lower lip 86 into discrete sections. Like the upper lip 85, the lower lip 86 terminates inboard of the side 81 and outboard of the side 82. In this way, multiple battens 13 can be placed side-by-side along the lower end of the roofing system 10 and nest with each other. When the battens 13 are so arranged, and when they are fastened to the roof support structure 17, the battens 13 support all tiles 11 and 12 laid onto the roof support structure 17 above the battens 13.

[0047] The side trim 14 holds down the sides of the roofing system 10 and prevents its lateral movement. FIG. 5 illustrates the side trim 14 from an inverted perspective. The side trim 14 is shaped like an angle beam: it is elongate, has opposed sides 90 and 91, and has an upright back 93 and a flat top 92. The back 93 projects downwardly from the rear of the top 92, and conversely, the top 92 projects forwardly from the top of the back 93. The top 92 and back 93 are perpendicular to each other. The top 92 includes three pairs of parallel slots 94 aligned between the sides 90 and 91. The side trim 14, as shown in FIG. 1, is registered with and positioned over each tile 11 (or 12) on the side of the roof support structure 17. When so positioned, the back 93 depends from the corner and the top 92 extends over the tile 11 (or 12). The slots 94 in the back 93 allow air to flow under the tile 11 secured by the side trim 14. The side trim 14 thus

acts as a water barrier to the side of the tile and also acts as fastener additionally securing the tile to the roof support structure 17.

[0048] Turning now to FIG. 6, a top perspective view illustrates the ridge cap 15, which includes a rounded ridge 100 and two leaves 101 and 102 formed rigidly, integrally, and monolithically to the ridge 100. Each leaf 101 and 102 is oriented obliquely to the ridge 100 so as to straddle the ridge of the roof when installed. The ridge cap 15 has an underside 103. A plurality of ribs 104 spaced apart between the opposed ends of the ridge cap 15 project down from the underside 103 and also slightly above through the top surface of the ridge cap 15. The ribs 104 extend across the leaf 101, the ridge 100, and the leaf 102, strengthening and providing rigidity to the entire ridge cap 15.

[0049] Returning to FIG. 1, the tiles 11 and 12 are shown placed together in an alternating fashion. Because the frames 21 and 51 are similar, and all the engagement elements of the frames 21 and 51 are the same, the tiles 11 and 12 can be placed together in any pattern. For instance, they may be installed as a row of solid panel tiles 11 with a row of PV panel tiles 12 above, and then another row of solid panel tiles 11 with another row of PV panel tiles 12 above that, etc. Or, the roofing system 10 may be constructed only with the solid panel tiles 11 or only with the PV panel tiles 12. Or the rows may include alternating or random patterns of tiles 11 and 12. The solid panel tiles 11 fit into and engage with other solid panel tiles 11 just as well as they do with the PV panel tiles 12.

[0050] The tiles 11 and 12 are constructed from a rigid, strong, lightweight material such as plastic, metal, or structural foam, and they have fire retardant and UV protective characteristics. Further, the tiles 11 and 12 are produced in a variety of colors. While black or slate grey is a popular color for conventional roofing tiles in much of America, in the southwest, Spanish tiles are typically light brown or orange. The tiles 11 and 12 are produced in black, brown, white, and other colors so that a roof can be a solid color or can be patterned with several colors.

[0051] The PV panel tiles 12 are slightly different from the solid panel tiles 11. The PV panel tiles 12 carry the photovoltaic panels 110 (or “panels 110” or PV panels 110”) for generating electricity from sunlight, as shown in FIG. 1. The photovoltaic panels 110 are thin and rectangular and fit snugly within the frame 51 of the tile 12. Turning now to FIG. 3A, each of the elements s 52-55 of the frame 51 includes an inwardly-directed lip or flange 111 that projects laterally into the open central panel area 50. These flanges 111 support the photovoltaic panels 110 in the open central panel area 50 but also act as secondary channels for water.

[0052] The flanges 111 include a lateral projection into the open central panel area 50 and an inboard upstanding lip. As such, the flanges 111 on the left and right elements 54 and 55 cooperate with the flanges 111 on the upstream element 52 and downstream element 53 to define a continuous channel 112 extending around the perimeter 56. This channel 112 is inboard and along each of the left and right elements 54 and 55 and the upstream and downstream elements 52 and 53. Although the channel 112 is continuous, it is open at the downstream end at a notch or outlet. The downstream element 53 has a body which is delineated from the left and right elements 54 and 55 by two such notches or outlets 113. The channel 112 terminates along the left and

right elements 54 and 55 in these outlets 113, such that the channel 112 at the left and right elements 54 and 55 has open downstream ends.

[0053] Water that is deposited on the photovoltaic panel 110 will stream to the edges of the panel 110 and fall off the panel 110, into the flanges 111. The flanges 111, as part of the channel 112, then collect and channel the water toward the outlets 113 at the downstream element 53. In the tile 12, the outlets 113 are registered with and coextensive to the flanges 111, such that water channeling down the flanges 111 along the left right elements 54 and 55 run through the outlets 113 and onto the tile 11 or 12 below. In this way, a channeling system, secondary to the primary channel formed by the side engagement elements, acts to catch and direct water off the roofing system 10.

[0054] The photovoltaic panels 110 are secured in the frames 51 by two triangular clamps 16 at their lower corners, as shown in FIGS. 1 and 8, and by a tile placed above. The triangular clamps 16 fit over the panels 110 and are secured with fasteners 114 that engage with bores 105 in the downstream element 53. The triangular clamps 16 overlie the channels 112 proximate the left and right elements 54 and 55, and so therefore do not impede the flow of water in the flanges 111 through to the outlets 113. The upper end of the PV panels 110 are held in the central panel area 50 by the downstream element 53 of the tile 12 which is upstream of the tile 12 holding the PV panel 110; the downstream element 53 laps slightly over the PV panel 110 to keep it in place.

[0055] Again, the tiles 11 and/or 12 can be arranged in any pattern in the roofing system 10. The tiles 11 and 12 will not remain long on the roof support structure 17 without securement, however. Together with fasteners such as the fastener 76, the locking batten 13, side trim 14, and ridge cap 15 provide much of this security; nails or bolts fasten each to the roof support structure 17. At the downstream or lower edge of the roof support structure 17, the locking batten 13 (or several thereof) is directed upward and secured to the roof support structure 17 so that the lips 85 and 86 are directed up the roof support structure 17. A first row of tiles 11 and 12 is then applied to the battens 13; the latches 42 and 72 of the tiles 11 and 12 are fit into the battens 13 between their upper lips 85 and lower lips 86.

[0056] Several tiles 11 and/or 12 are applied to the batten to start this first row. For ease of discussion, this description will be made without reference to two tiles 11 and 12, with the understanding that either of the tiles 11 or 12 may and will be used in any combination. A first tile 11 is placed into the batten 13. A second tile 12 is then placed next to the first tile 11. To place the second tile 12, it is taken up by hand, and its side element (for example, its right element 55) is registered with the left element 24 of the tile 11. The installer engages the rail 61 of the second tile 12 with the rail 35 on the first tile 11 and then slides the second tile 12 downstream, locking the two adjacent tiles to each other. The rails 35 and 61 are thus fully engaged, forming a secure engagement assembly between the first and second tiles 11 and 12. This process is repeated with several more tiles 11 and/or 12 in the row.

[0057] Further, because the latches 42 and 72 are tongues fit in the grooves of the batten 13, the row of tiles 11 and/or 12 can be slid laterally left or right along the batten 13. Thus, once a few tiles are in place in the first row, the installer slides the tiles 11 and/or 12 into alignment in the desired

location. In some cases, thinner tiles may be necessary, such as if the row of tiles needs to have a half-width tile at the end, and so, thinner solid tiles **11** are used. While FIGS. 2A-3B show the tiles **11** and **12** as having the same width (between their left and right elements), the solid tiles **11** are produced in differing widths, such as full-width, half-width, one-third-width, etc., as needed. Moreover, the solid tiles **11** can also be cut to size in some embodiments. Accordingly, differing-width solid tiles **11** may be used to appropriately space the row of tiles as desired.

[0058] Once the installer has correctly positioned and filled the first row of tiles **11** and/or **12**, he secures them. This is done with fasteners and with the side trim. The installer picks up two fasteners and passes each through the holes **45** (in tile **11**) and holes **75** (in tile **12**) into the roof support structure **17**. As shown in FIG. 7, the fasteners **76** secure the upstream end **52** of the tile **12**; the upstream element **22** of the tile **11** is similarly secured.

[0059] The side trim **14** is then applied over the tiles **11** or **12** on the left and right ends (only a left end is shown in FIG. 1). The side trim **14** is registered with the end tiles **11** and/or **12** and fastened there. Fasteners are applied through the back **93** into the roof support structure **17**, and the top **92** laps over and holds down the tiles **11** or **12**. Where the end tiles are solid tiles **11**, fasteners may be applied through the top **92** of the side trim **14** into the panel **20** of the solid tile **11**. In this manner, the first row is assembled and secured.

[0060] A second row of tiles **11** and/or **12** is then assembled, in the same fashion, but with the latches **42** (or **72**) of the downstream elements **23** (or **53**) of the tiles **11** (or **12**) in the second row engaging with the upstream elements **22** (or **52**) of the tiles **11** (or **12**) in the first row, in the manner described above. The second row—or the first few tiles **11** and/or **12** of the second row—is then slid left or right to laterally position the second row as desired.

[0061] FIG. 7 shows a side elevation of a row of PV panel tiles **12** with a downstream row of solid tiles **11**. When the rows of tiles **11** and **12** are assembled, the upstream row of tiles **12** is coupled to the downstream row of tiles **11**. The latches **72** extending from underneath the downstream element **53** of the upstream tile **12** is clipped onto the upstream element **22** of the downstream tile **11**. Each upstream tile **12** in the row is clipped into the tiles **11** in the lower row in this manner, and this secures the upstream row to the downstream row. The upstream element **52** of each tile is also secured with a fastener **7**. All other rows are then assembled in this fashion until the ridge is reached, at which point the ridge cap **15** is fit over and secured to the top rows of tiles **11** and **12**.

[0062] The photovoltaic panels **110** generally have local inverters on their undersides. Wiring for these inverters runs under the tiles **11** and **12**, typically to a harness that is connected between a main electrical line and several inverters, so that when a panel **110** needs to be replaced, it can be quickly disconnected from the harness and replaced. To replace, the clamps **16** are simply removed, the panel **110** is lifted, disconnected, and fully removed. A new panel **110** is then coupled to the harness, slid into the open central panel area **50**, and aligned in place therein. The clamps **16** are then returned to their original positions and secured with fasteners. The new panel **110** is now easily and securely held in the tile **12** by the clamps **16** and by the overhanging lip of the tile **11** or **12** above it.

[0063] FIG. 9 is a top perspective view of an alternate embodiment of a roofing system **120**. Unlike FIG. 1, FIG. 9 illustrates a substantially complete roofing system **120** as it would appear on one full portion of a rectangular roof support structure **17**.

[0064] The roofing system is constructed from individual, light, small, modular roof tiles **121**. Each roof tile **121**, but for the ones on the ends, is locked to its neighboring tiles **121** on all four sides, and therefore cooperates with the other roof tiles **121** to present a continuous surface of the roofing system **120**. FIG. 9 illustrates one embodiment of the roofing system **120**, in which all of the tiles **121** include an encapsulated solar panel; in some embodiments, some of the tiles **121** are blanks, or solid tiles similar to the solid tiles **11**, as will be described below.

[0065] FIGS. 10A and 10B illustrate one of the roof tiles **121** from the roofing system **120**. The tiles **121** are identical, and so description here need only refer to one of the tiles **121**, and the reader will understand that the description applies equally to all of the tiles **121** shown in the embodied roofing system **120**. The tile **121** is rectangular, and thus has a top **122**, an opposed bottom **123**, a first or left side **124**, and an opposed second or right side **125**. The top **122** and bottom **123** are parallel to each other and perpendicular to each of the left and right sides **124** and **125**, which are parallel to each other. Moreover, the top **122** and bottom **123** are coextensive to each other, and the left and right sides **124** and **125** are coextensive to each other, because the roof tiles **121** interlock and engage with each other to form the roofing system **120**. The roof tile **121** has a generally flat upper surface **126** and a generally flat lower surface **127**.

[0066] The roof tile **121** includes a photovoltaic panel **130** (or “panel **130**” or “PV panel **130**”) encapsulated in a frame **131** to form a unitary body **132**. Together, the PV panel **130** and frame **131** cooperate to form a strong, durable, rugged, and weather-proof body **132**, adapted to be fit together with other roof tiles **121** to form the strong, durable, rugged, and weather-proof roofing system **120**. Unlike conventional solar panel tiles in which a PV panel is installed or adhered to a cutout, void, or pocket in a structural frame, the PV panel **130** is formed integrally to the frame **131** during manufacture.

[0067] Manufacture of the roof tile **121** occurs in a single machine, such as a vertical-press, horizontal-injection machine with a four-station turn table. In such a machine, the PV panel **130** is held suspended in a mold, the material for the body **132** is injected around the PV panel **130**, and the tile **121** is then allowed to cure and cool. By injecting the body **132** material around the PV panel **130**, the PV panel **130** is entirely encapsulated.

[0068] Encapsulation means, at least, that the edges of the PV panel **130** are sealed or covered by the body **132**, and yet the face of the PV panel **130** is still available to receive solar energy, and the underside of the PV panel **130** is still available for electrical connections. The PV panel **130** is a thin sheet, having a top and bottom, and opposed top and bottom edges and opposed side edges. One side edge **133** and the bottom edge **134** are shown in broken line within the body **132** in FIGS. 10A and 10B. On the upper surface **126** of the tile **121**, the body terminates inwardly at an inner lip **135**, as shown in FIG. 10A, bounding and defining an open central panel area **136** in which the front of the PV panel **130** is exposed for gathering sunlight. The inner lip **135** extends inboard of both the side edge **133** and the bottom edge **134**.

Indeed, the inner lip **135** also extends inboard of the side edge opposing the side edge **133** and the top edge opposing the bottom edge **134**. In this way, the lip **35** overlaps each of the edges of the PV panel **130** on the upper surface **126**, encasing them, so that the PV panel **130** is encapsulated both above and below.

[0069] The lower surface **127** is also encapsulated, as shown in FIG. 10B. On the lower surface **127** of the tile **121**, a support structure is formed. Two long rails **140** and **141** extend parallel to the sides **124** and **125** entirely between the top **122** and bottom **123**. They are spaced in from the sides **124** and **125**, but support ribs **142** extend from the side **124** to the rail **140** and from the side **125** to the rail **141**. The rails **140** and **141** and the ribs **142** are integral parts of the body, and they support the slight weight of the PV panel **130** across its area within the lip **135**, though the entire tile **121** weighs only two pounds. Moreover, the rails **140** and **141** leave a rectangular space or channel **143** that extends between the top **122** and bottom **123**. The channel **143** is a receiving space for a junction box **144** and wiring **145** electrically coupled to the PV panel **130**. The body **132** on the underside of the PV panel **130** extends inboard of the side edge **133** and the bottom edge **134**. And, similarly, the body **132** extends inboard of the side edge opposing the side edge **133** and the top edge opposing the bottom edge **134**.

[0070] The body **132** is constructed from a structural foam with fire retardant and UV protective additives. Colorants are added to impregnate the body **132** with a color as desired, such as red, clay, orange, grey, slate, black, or other colors. The foam for the frame **131** is lightweight, strong, and durable. It is also rigid, such that the tile **121** can be formed with shapes to allow engagement of the tiles **121** together.

[0071] The tiles **121** engage with each other along their sides and tops and bottoms. Turning now to FIG. 11, which is a section view along lines 11-11 in FIG. 9 bisecting two tiles **121** along their lengths between their tops **122** and bottoms **123**, it can be seen that the tiles **121** have structure for forming this engagement. At the bottom of each tile **121** is a tongue assembly **150** for engaging with a groove assembly **151** formed at the top of each tile **121**.

[0072] The tongue assembly **150** includes a vertical sidewall **152** at the bottom **123** of the tile **121**. At the bottom of the sidewall **152**, a tongue **153** projects laterally outward and away from the body **132**, parallel to the body **132**. The tongue **153** is short. Above it, at the top of the sidewall **152**, an arm **154** projects laterally outward away from the body **132**, also parallel to the body **132**. The arm **154** terminates in a shoe **155**, oriented obliquely downward. The shoe **155** extends to below the lower surface **127** of the tile **121**, but not quite so far as the tongue **153**. The arm **154** and shoe **155** have a downward bias, along arrowed line A in FIG. 11. A receiving space **156** is defined between the sidewall **152**, the tongue **153**, the arm **154**, and the shoe **155**, with only a lower entrance opening into the space **156**.

[0073] The groove assembly **151** engages with the tongue assembly **150**. The groove assembly **151** is formed proximate the top **122** of the tile **121**. It includes a lip **160** projecting just above and laterally outward from the upper surface **126**, away from the body **132** of the tile **121**. Below the lip **160**, a lateral groove **161** is formed into the body **132**. Below the groove **161**, an upstanding endwall **162** is formed at the top **122**, spaced slightly outboard from the groove **161**. The groove **161** is sized and shaped to snugly receive the

tongue **153**. As such, the tongue assembly **150** locks into the groove assembly **151**. When it does, as shown in FIG. 11, the lip **160** is disposed in the receiving space **156**, and the shoe **155** rests against the upper surface **126**. The shoe **155** presses down on the upper surface **126**, thereby biasing the tongue **153**, the groove **161**, and the lip **160** into confrontation. This ensures contact which establishes a water impermeable seal. Thus, the engagement of the tongue assembly **150** and the groove assembly **151** is waterproof. Further ensuring this waterproofness, the arm **154** and the shoe **155** overlap the engagement of the lip **160**, tongue **153**, and groove **161**, thereby protecting them from weather exposure. The lip **160** acts to shed water down the tile **121** away from the seam between the two tiles **121**. The lip **160** also acts as a wind barrier, deflecting wind up and over the tile **121**. This engagement allows two tiles stacked one above the other to slide laterally relative each other while remaining engaged.

[0074] FIG. 12 shows an alternate version of a tongue assembly **181** and a groove assembly **180** at the top **122** and bottom **123** of tiles **121'**. FIG. 12 is a section view taken along the line 12-12 in FIG. 9. The tiles **121'** are identical to the tiles **121** in all aspects except for the tongue and groove assemblies. As such, the same reference characters are used with respect to both tiles **121** and **10'** but for the structure elements and features which differ. The tongue assembly **181** includes a blunt tongue **182** which projects laterally outward away from the body **132**, contiguous with the upper surface **126**. The tongue **182** has a flat top **183**, a blunt end **184**, and a flat bottom **185**.

[0075] The groove assembly **180** includes a lip **190** projecting laterally outward from the body **132** of the tile **121'**, also contiguous with the upper surface **126** of the tile **121'**. The lip **190** has a flat top **191**, a beveled end **192**, and a flat bottom **193**. Below the lip **190**, the groove assembly **180** includes another lip **194** which is much smaller than the lip **190**. The lower lip **194** is disposed below the lower surface **127** of the tile **121'** and projects laterally outward from the body **132** a shorter distance than does the lip **190**. The lower lip **194** includes a flat top **195**, a blunt end **196**, and a flat bottom **197**. A groove **198** is defined between the lips **190** and **194**; the groove **198** is sized and shaped to snugly receive the tongue **182**. When it does, the lip **190** projects far over the upper surface **126** of the other tile **121'**, such that its end **192** is proximate to the inner lip **135**, and the bevel on the end **192** corresponds to the bevel at the lip **135**, so that wind flows over each smoothly and water streams over both without seeping into or between either tile **121'**. This engagement allows two tiles stacked one above the other to slide laterally relative each other while remaining engaged.

[0076] The tiles **121** are engaged with each other at their sides as well. FIG. 13 is an enlarged view of a left side **124** of a tile **121** and a right side **125** of an adjacent tile **121**. Each left side **124** of every tile **121** is identical, and each right side **125** of every tile **121** is identical, so that all tiles **121** can be stacked and engaged side-by-side to all other tiles **121**. The left side **124** of the tile **121** includes a laterally-projecting edge **170** which has a flat top contiguous with the upper surface **126** and which terminates with a downwardly-turned endwall **171**. The endwall **171** extends downwardly to a convex tongue **172**, which curves into a concave groove **173**. The groove **173** is inboard from the tongue **172** and is larger than the tongue **172**. The convex groove **173** terminates inwardly at the lower surface **127** of the tile **121**.

[0077] The right side 125 is formed with complementary structure. The right side 125 has a laterally-projecting edge 174 which has a flat bottom contiguous with the lower surface 127 and which terminates with an upwardly-turned endwall 175. The endwall 175 is short, approximately one third the length of the endwall 171. The endwall 175 extends upwardly to a convex tongue 176, which curves into a concave groove 177. The groove 177 is inboard from the tongue 176 and is smaller than the tongue 176. The groove 177 is sized and shaped to receive the tongue 172, and the groove 173 is sized and shaped to receive the tongue 176, such that two overlapping engagements are formed when the left and right sides 124 are brought together. Note that although FIG. 13 indicates material between the tongue 176 and the groove 177, this space is occupied by air in good weather and rain in inclement weather—this engagement acts as a channel for water.

[0078] In operation, the tiles 121 (or the tiles 121') are engaged with each other to form the roofing system 120 of FIG. 9. They are laid atop a building instead of conventional roofing tiles, and so they replace the traditional heavy roof and the solar panel arrays generally mounted above such traditional roofs. These tiles 121 offer a lightweight yet durable, energy-generating replacement for conventional roofs. The PV panels 130 used in the tiles 121 (and the tiles 121') are 132-watt panels, capable of producing 14.3 watts per square foot. This is a reasonably high yield, and so in some cases, the entire roof may not need to be covered in tiles 121 with encapsulated PV panels 130. Rather, some tiles may have the same construction as described above but be made continuously from structural foam without an encapsulated PV panel 130. Such tiles are “blanks,” and can be inserted into the roofing system 120 as needed or desired. In some cases, blanks are used in areas that receive less sunlight, such as beneath a tree. In other cases, the homeowner may desire a pattern of alternating PV panel tile 121—blank tile 121 across their roof. In short, there are many reasons to use the blanks. The roofing system 120 could even be constructed entirely from blanks. In other embodiments of the tile 121, the PV panel 130 is replaced by a glass, plastic, or other transparent or translucent material, so as to be used as a skylight.

[0079] The tiles 121 (or tiles 121') are electrically coupled together and to a central inverter, unless their power is converted locally at the junction box 144. The power produced by the tiles 121 is then available to be used by the home or building or returned to the electrical grid for distribution.

[0080] A preferred embodiment is fully and clearly described above so as to enable one having skill in the art to understand, make, and use the same. Those skilled in the art will recognize that modifications may be made to the description above without departing from the spirit of the specification, and that some embodiments include only those elements and features described, or a subset thereof. To the extent that modifications do not depart from the spirit of the specification, they are intended to be included within the scope thereof.

What is claimed is:

1. A roofing system for forming a roof, the roofing system comprising:

a plurality of tiles, each tile having a frame at a perimeter of the tile, the frame comprised of an upstream element,

an opposed downstream element, and opposed first and second side elements, cooperating to bound a central panel area which is open;

the first side element has an upstanding groove and the second side element has a complementary downturned tongue configured to snugly fit into the groove and define a primary channel under the tongue for carrying water toward the downstream element;

each of the upstream, downstream, and first and second side elements includes a flange projecting laterally into the central panel area, said flanges each including a lateral projection and an upstanding lip and together cooperating to form a secondary channel extending continuously around and inboard of the perimeter;

wherein the secondary channel is inboard of the primary channel;

a photovoltaic panel carried in each tile, the photovoltaic panel supported by the flanges such that, when the photovoltaic panel is carried in the tile, the photovoltaic panel is snugly fit within the frame and overlies the flanges but allows water to flow over the photovoltaic panel and into the secondary channel each of the upstream, downstream, and first and second side elements;

at least one each of a side trim, a batten, and a ridge cap; and

when the tiles, side trim, batten, and ridge cap are arranged to form a roof, the batten is secured at a lower edge of the roof and directed upward to receive the tiles at the lower edge, the side trim is secured at a side edge of the roof and directed laterally to receive one of the first and second side elements of the tiles at the side edge, and the ridge cap is secured at a ridge of the roof and directed downward to lap over the upstream elements of the tiles at the ridge.

2. The roofing system of claim 1, wherein the photovoltaic panel is carried in the central panel area of the tile for removable replacement therefrom.

3. The roofing system of claim 2, further comprising clamps between the downstream element and each of the first and second side elements, wherein the clamps hold the photovoltaic panel against the frame in the central panel area.

4. The roofing system of claim 1, further comprising diagonal spars extending across the central panel area from corners between the upstream, downstream, and first and second side elements.

5. The roofing system of claim 1, wherein the flanges along the first and second side elements are each registered with an outlet of the continuous channel disposed between the downstream element and each of the first and second side elements, respectively.

6. The roofing system of claim 1, further comprising risers on an underside of each tile, wherein the risers have heights, and the heights of the risers proximate the downstream element are greater than the heights of the risers proximate the upstream element.

7. The roofing system of claim 16, further comprising latches projecting forwardly from underneath the downstream element, the latches corresponding in height to the upstream element.

8. (canceled)

9. The roofing system of claim 1, wherein the upstream and downstream elements have coextensive widths, such

that when the roof is formed, the downstream element of one of the tiles laps over both the upstream element and a photovoltaic panel of another of the tiles below the one of the tiles.

**10.** A roofing system for forming a roof, the roofing system comprising:

a plurality of tiles, each tile having a frame at a perimeter of the tile, the frame comprised of an upstream element, an opposed downstream element, and opposed first and second side elements, cooperating to bound a central panel area;

the first side element has an upstanding groove and the second side element has a complementary downturned tongue configured to snugly fit into the groove and define a primary channel under the tongue for carrying water toward the downstream element;

each of the upstream, downstream, and first and second side elements includes a flange projecting laterally into the central panel area, the flanges of each including a lateral projection and an upstanding lip and cooperating to form a secondary channel extending continuously around and inboard of the perimeter;

wherein the secondary channel is inboard of the primary channel;

at least one each of a side trim, a batten, and a ridge cap; and

when the tiles, side trim, batten, and ridge cap are arranged to form a roof, the batten is secured at a lower edge of the roof and directed upward to receive the tiles at the lower edge, the side trim is secured at a side edge of the roof and directed laterally to receive one of the first and second side elements of the tiles at the side edge, and the ridge cap is secured at a ridge of the roof and directed downward to lap over the upstream elements of the tiles at the ridge.

**11.** The roofing system of claim **10**, further comprising diagonal spars extending across the central panel area from corners between the upstream, downstream, and first and second side elements.

**12.** The roofing system of claim **10**, further comprising risers on an underside of each tile, wherein the risers have heights, and the heights of the risers proximate the downstream element are greater than the heights of the risers proximate the upstream element.

**13.** The roofing system of claim **10**, further comprising latches projecting forwardly from underneath the downstream element, the latches corresponding in height to the upstream element.

**14.** The roofing system of claim **10**, wherein the first side element has an upstanding groove and the second side element has a complementary downturned tongue configured to snugly fit into the groove and leave a primary channel in the groove under the tongue.

**15.** A roofing system for forming a roof, the roofing system comprising:

a roof tile having a body with a top, an opposed bottom, opposed first and second sides, and opposed upper and lower surfaces;

a photovoltaic panel encapsulated within the body of the roof tile between the upper and lower surfaces;

a tongue assembly at the bottom of the panel, and a groove assembly at the top of the panel, the tongue and groove assemblies for coupling to other tiles placed above and below the tile; and

wherein the tongue assembly includes a tongue and an arm that projects laterally away from the body of the tile above the tongue and terminates in a downwardly-turned shoe, the shoe biased downwardly so that, when the tile is coupled to one of the other tiles placed below it, the shoe rests against and presses down on an upper surface of the shoe.

**16.** The roofing system of claim **1**, further comprising: an inner lip of the body, the inner lip defining an open central panel area in which the photovoltaic panel is exposed; and

side edges of the photovoltaic panel;

wherein the inner lip extends inboard of the side edges, such that the side edges are encased within the body.

**17.** The roofing system of claim **1**, wherein, on the lower surface, the body includes first and second vertical rails extending between the top and bottom of the roof tile, defining a channel therebetween configured to receive an inverter, and ribs extending between the first and second vertical rails outward to the first and second sides of the body, respectively.

**18.** The roofing system of claim **1**, wherein the arm is disposed above the tongue.

**19.** The roofing system of claim **1**, wherein the shoe is disposed above the tongue.

**20.** The roofing system of claim **1**, further comprising: a second groove assembly formed along the first side of the tile; and

a second tongue assembly formed along the second side of the tile;

wherein the second tongue and groove assemblies are for coupling to laterally-adjacent tiles.

\* \* \* \* \*