



US00D341095S

United States Patent [19]

[11] Patent Number: Des. 341,095

Alden et al.

[45] Date of Patent: ** Nov. 9, 1993

[54] **PRESSURE TRANSMITTER**

[75] Inventors: **Jerome S. Alden**, Aurora; **Victor J. Budan**; **George S. Whaley**, both of Eastlake, all of Ohio

[73] Assignee: **Elsag International B.V.**, Amsterdam, Netherlands

[**] Term: **14 Years**

[21] Appl. No.: **880,365**

[22] Filed: **May 5, 1992**

[52] U.S. Cl. **D10/85; D10/46; D10/52**

[58] Field of Search **D10/46, 49, 50, 51, D10/52, 83, 85; 73/700-756; 340/606, 611, 612, 619, 626**

[56] **References Cited**

U.S. PATENT DOCUMENTS

D. 287,827	1/1987	Broden	D10/46
D. 296,995	8/1988	Lee	D10/46
D. 297,315	8/1988	Pierce et al.	D10/85
D. 316,975	5/1991	Brown et al.	D10/85
D. 317,266	6/1991	Broden et al.	D10/46
D. 317,269	6/1991	Selg	D10/85 X
4,745,810	5/1988	Pierce et al.	73/706

OTHER PUBLICATIONS

Rosemount Inc. (C) "Model 3051C Differential Pressure Transmitter" Product Data Sheet PDS 4622, 1 page.

Taylor Instrument, "500T Series Electronic Differential Pressure Transmitter" Data Sheet 503T-506T, File 12-7, 1 page.

Honeywell Inc., "ST 3000 Transmitter and SFC Smart Field Communicator" Data Sheet 34-ST-02-01, Feb. 1987, p. 1 of 4.

Rosemount Inc. (A) "Model 2024 Differential Pressure Transmitter" Product Data Sheet 2592, 1 page.
Rosemount Inc. (B) "Model 3051 Differential Pressure Transmitter" Product Data Sheet 2561, 1 page.
Bailey Controls "Smart Electronic Transmitters" Product Specification E21-30, Cover Page.
Foxboro Corp. 820 Series Intelligent Flow Transmitter, 1 page.
Fuji Electric Co. Ltd. "FC Series Pressure Transmitter" Data Sheet, 1 page.

Primary Examiner—Alan P. Douglas
Assistant Examiner—A. D. Davis
Attorney, Agent, or Firm—Michael M. Rickin; Paul R. Katterle

[57] **CLAIM**

The ornamental design for a pressure transmitter, as shown.

DESCRIPTION

FIG. 1 is a left side, top and front perspective view of a pressure transmitter showing our new design; FIGS. 2 and 3 are respectively top plan and bottom plan views thereof; FIGS. 4 and 5 are respectively left and right side elevational views thereof; and FIGS. 6 and 7 are respectively front and rear elevational views thereof; FIG. 8 is a close-up view of the ridges in the corrugated caps located at the front and rear of the transmitter; FIG. 9 is a left side, top and front perspective view of a second embodiment for the pressure transmitter showing our new design; FIGS. 10 and 11 are respectively top plan and bottom plan views thereof; FIGS. 12 and 13 are respectively left and right side elevational views thereof; and, FIGS. 14 and 15 are respectively front and rear elevational views thereof.

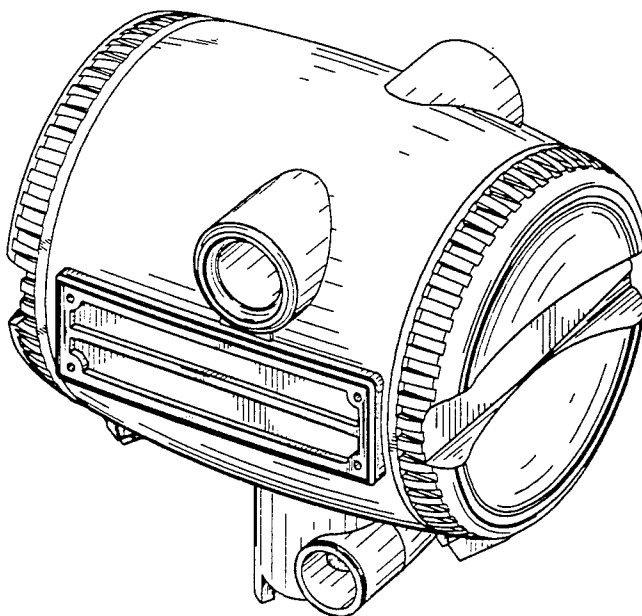

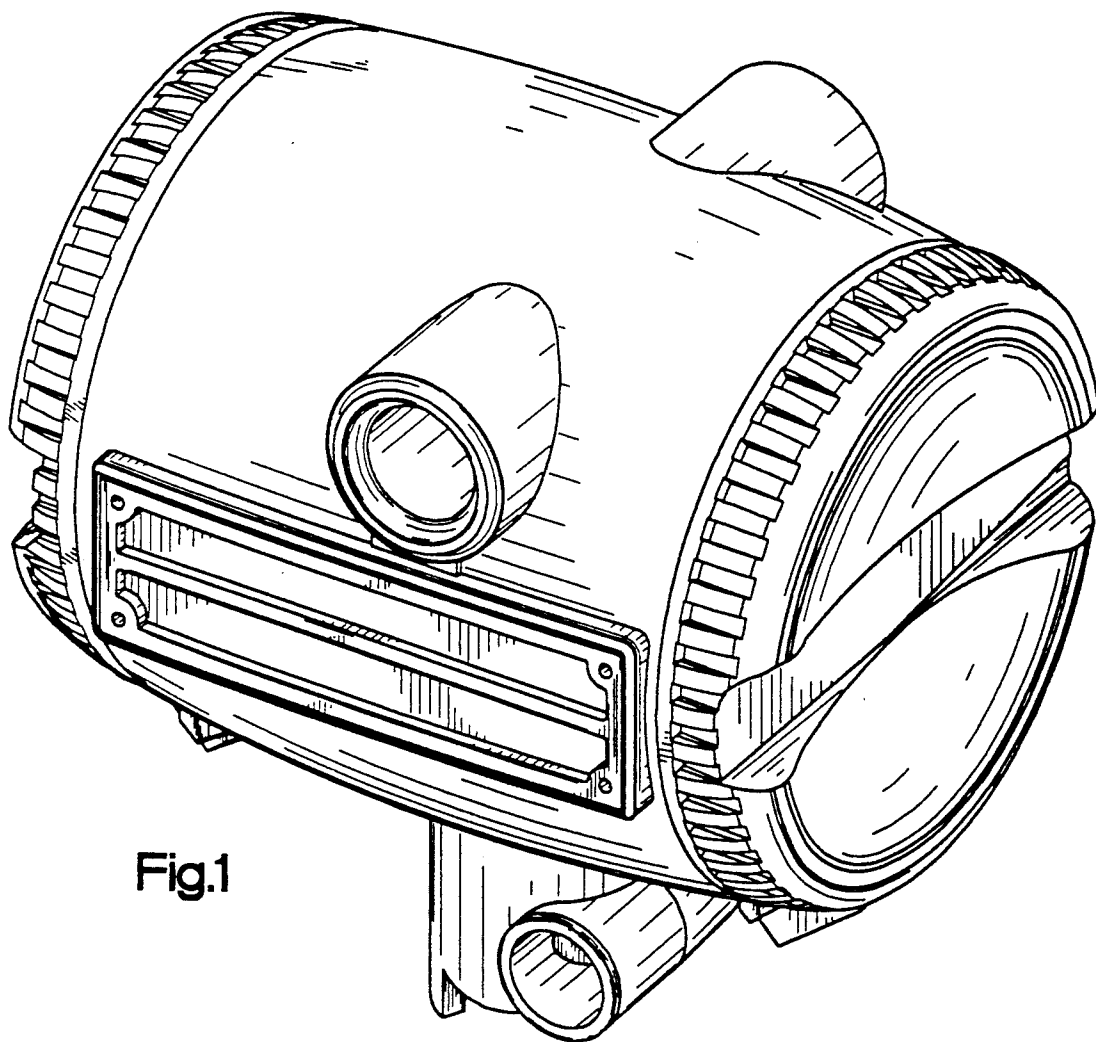

Fig.1

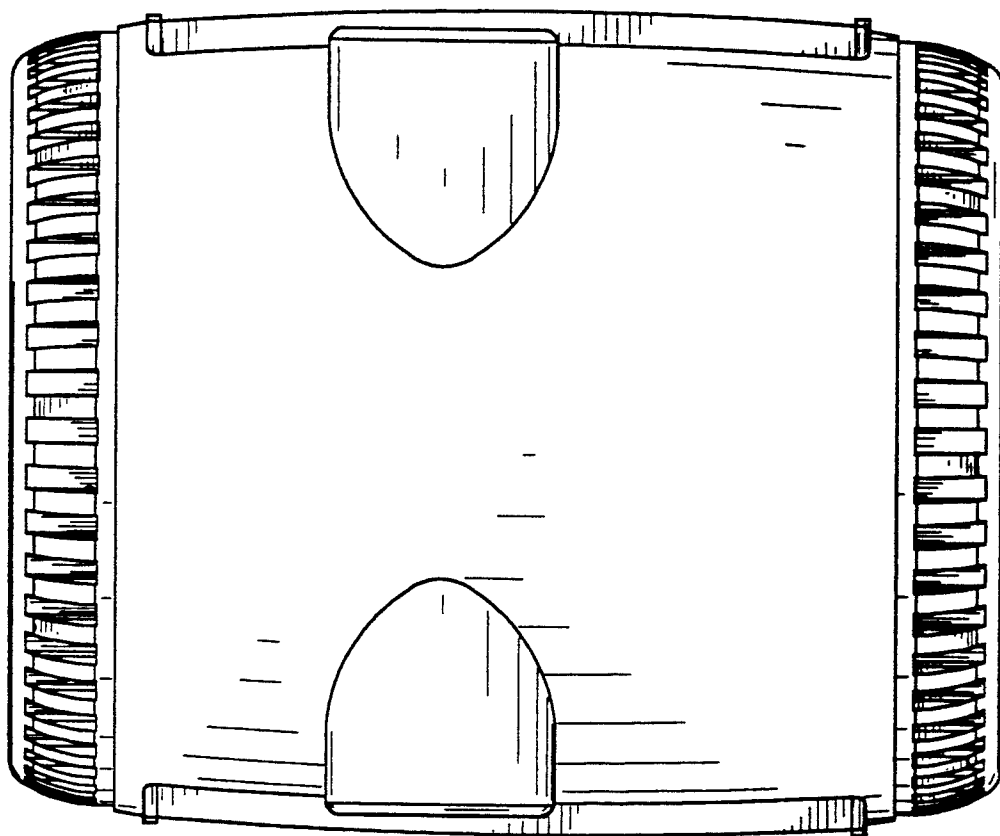

Fig.2

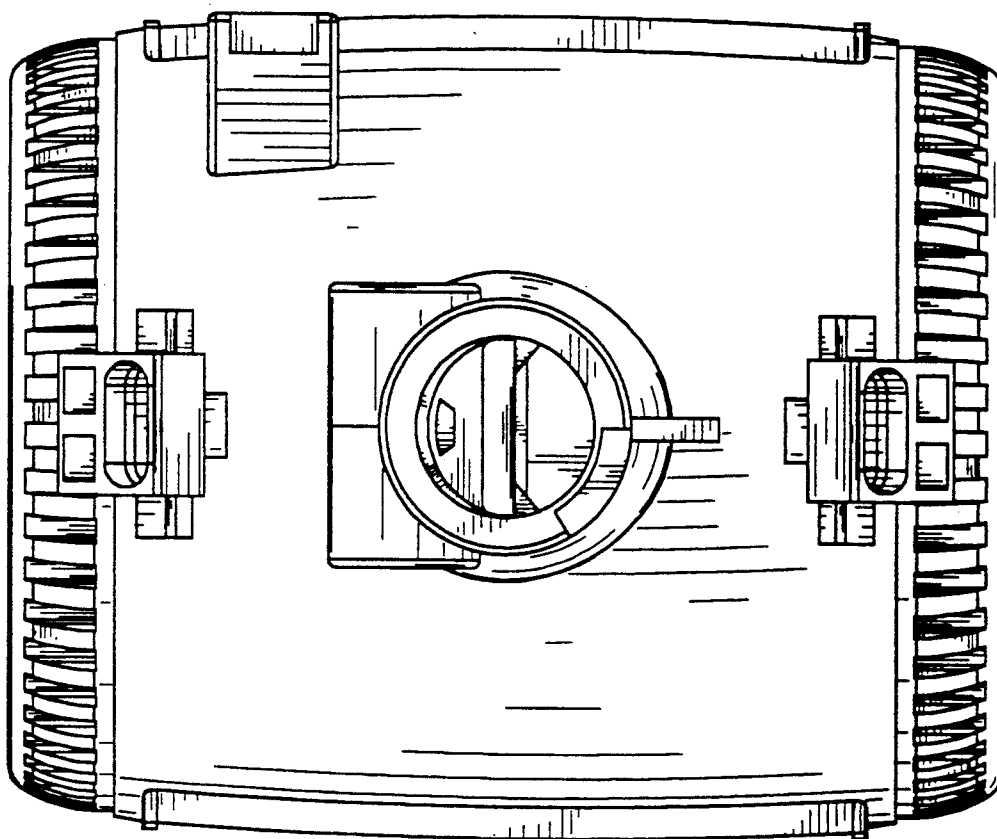

Fig.3

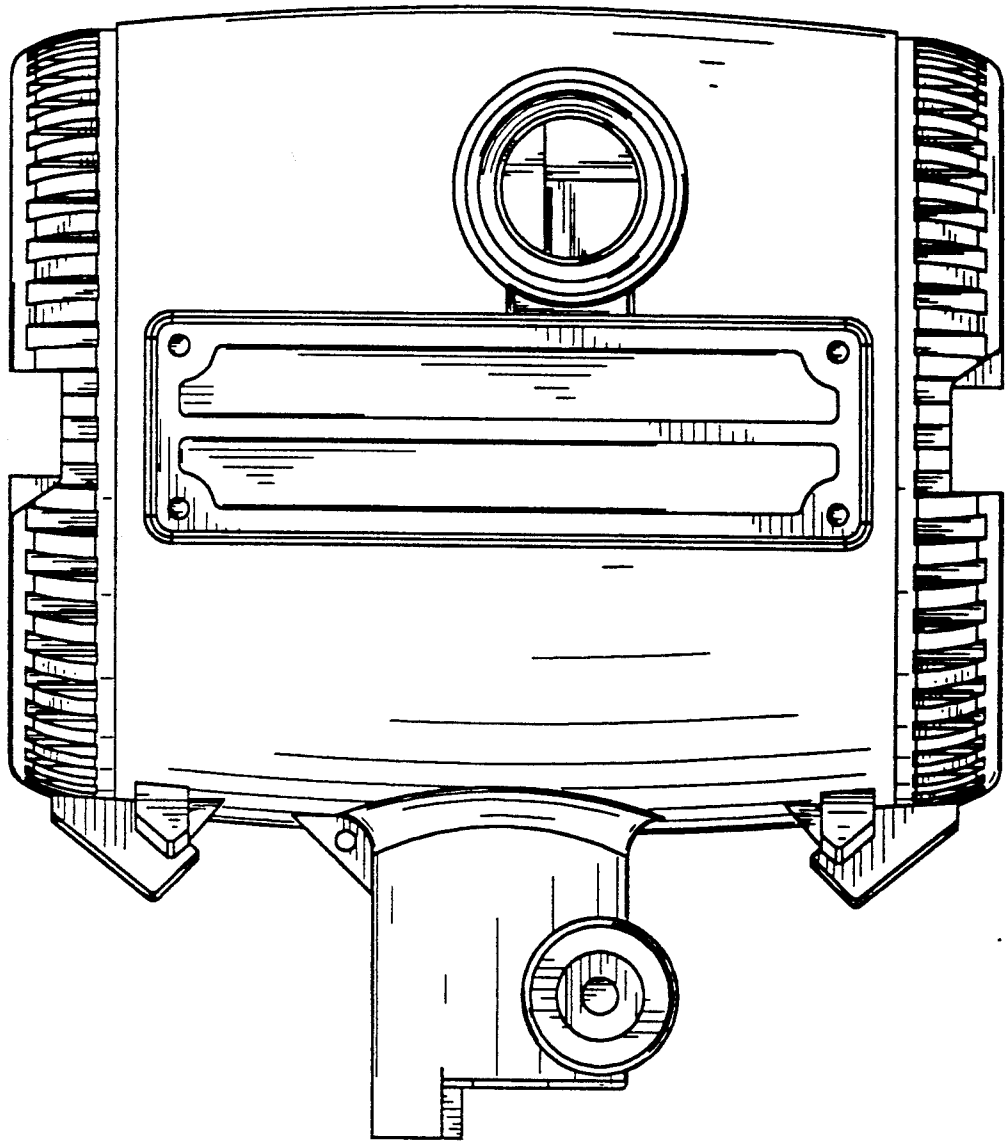

Fig.4

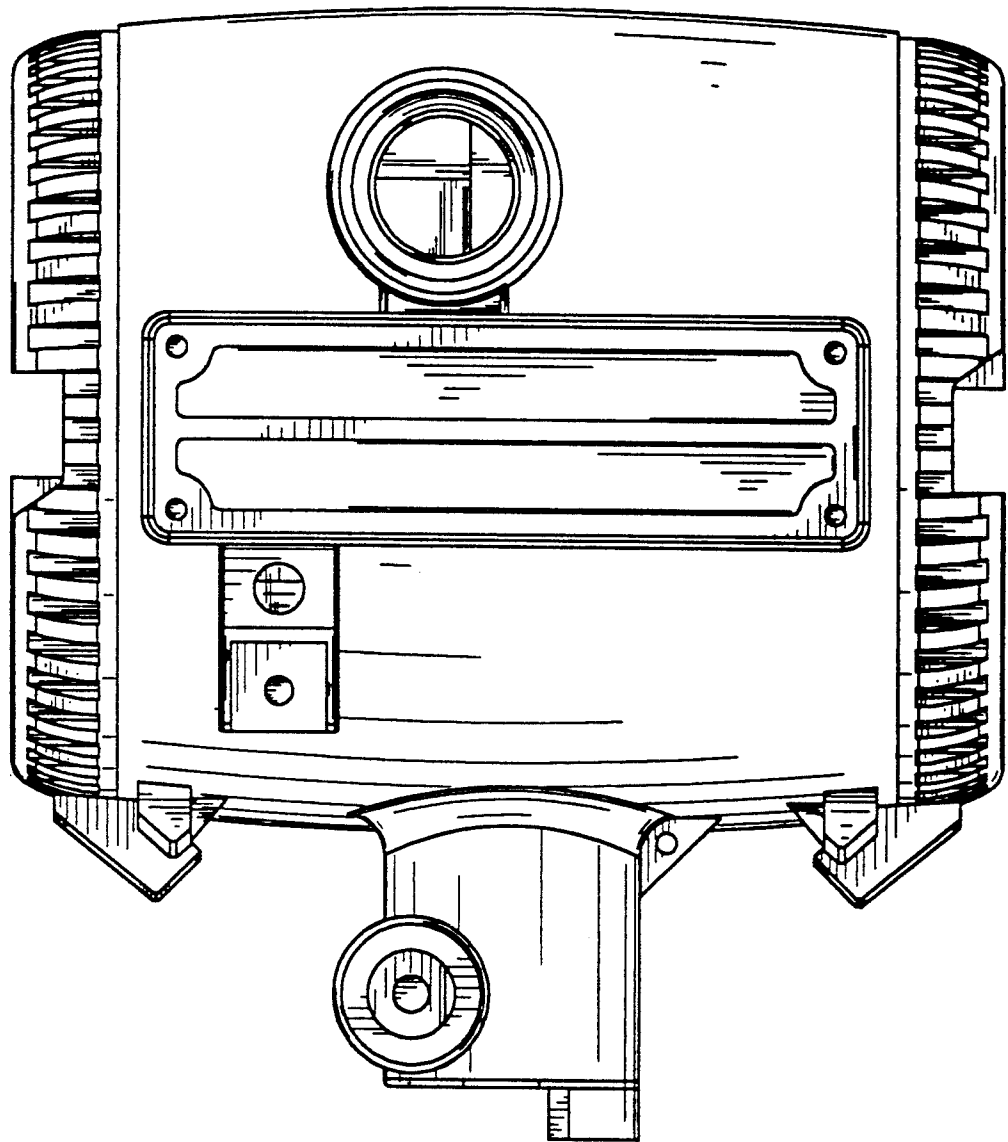

Fig.5

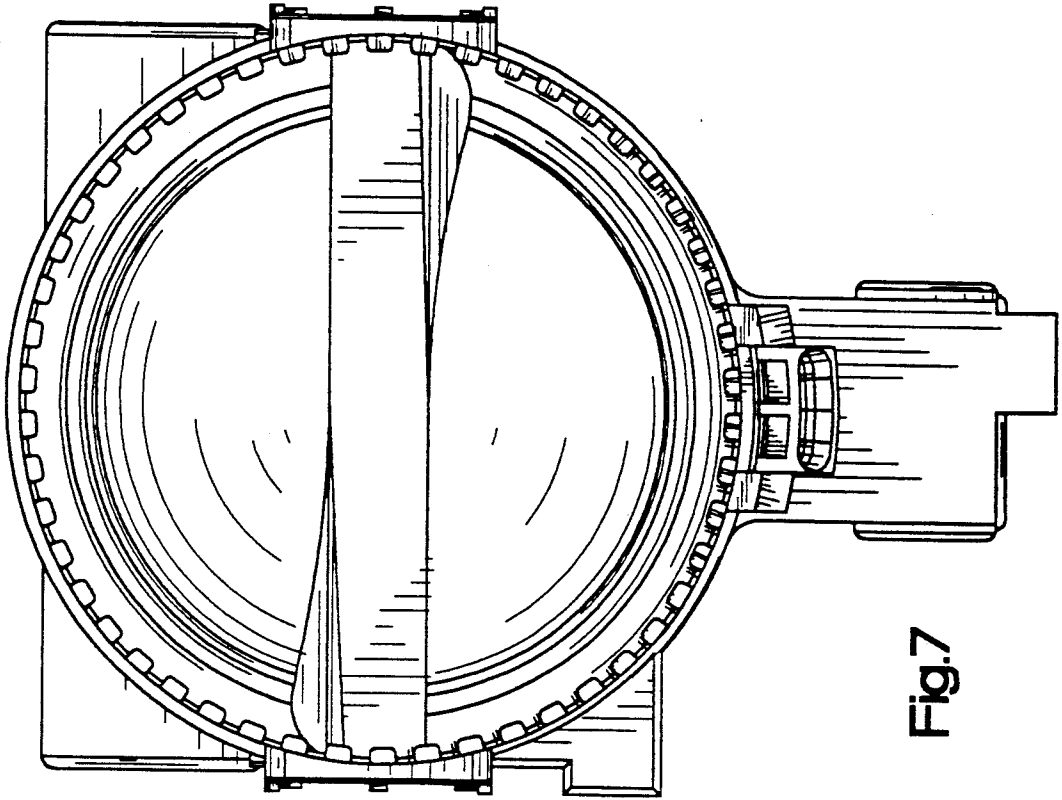

Fig.7

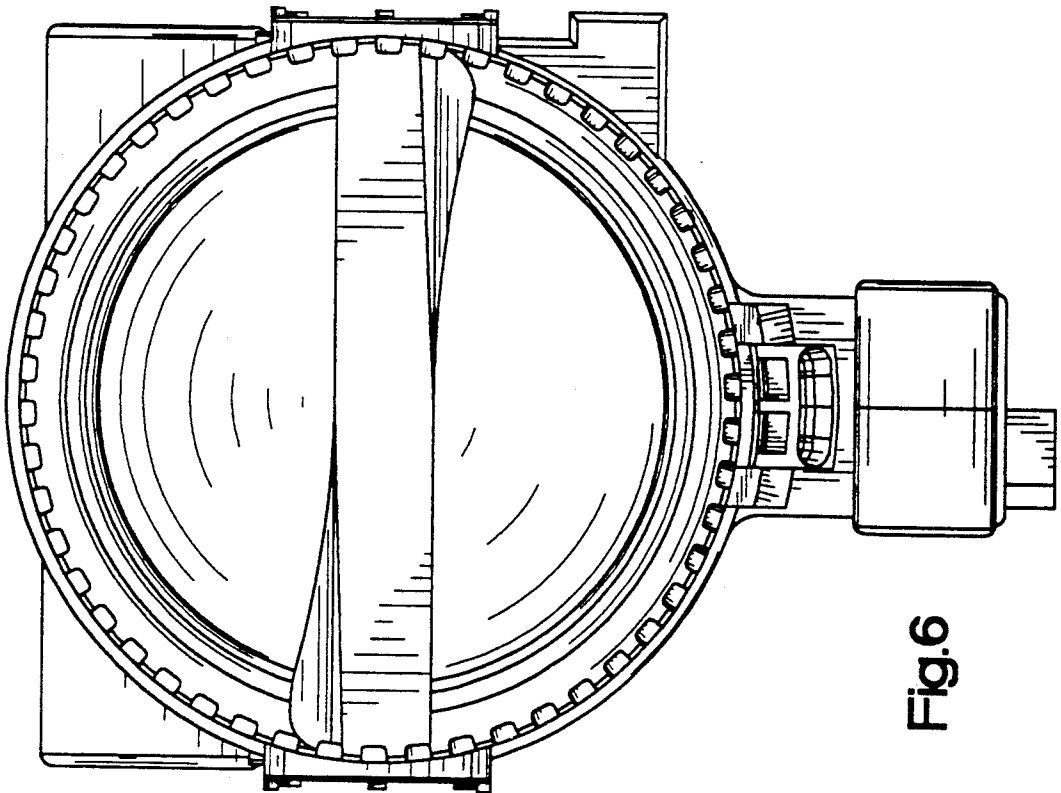

Fig.6

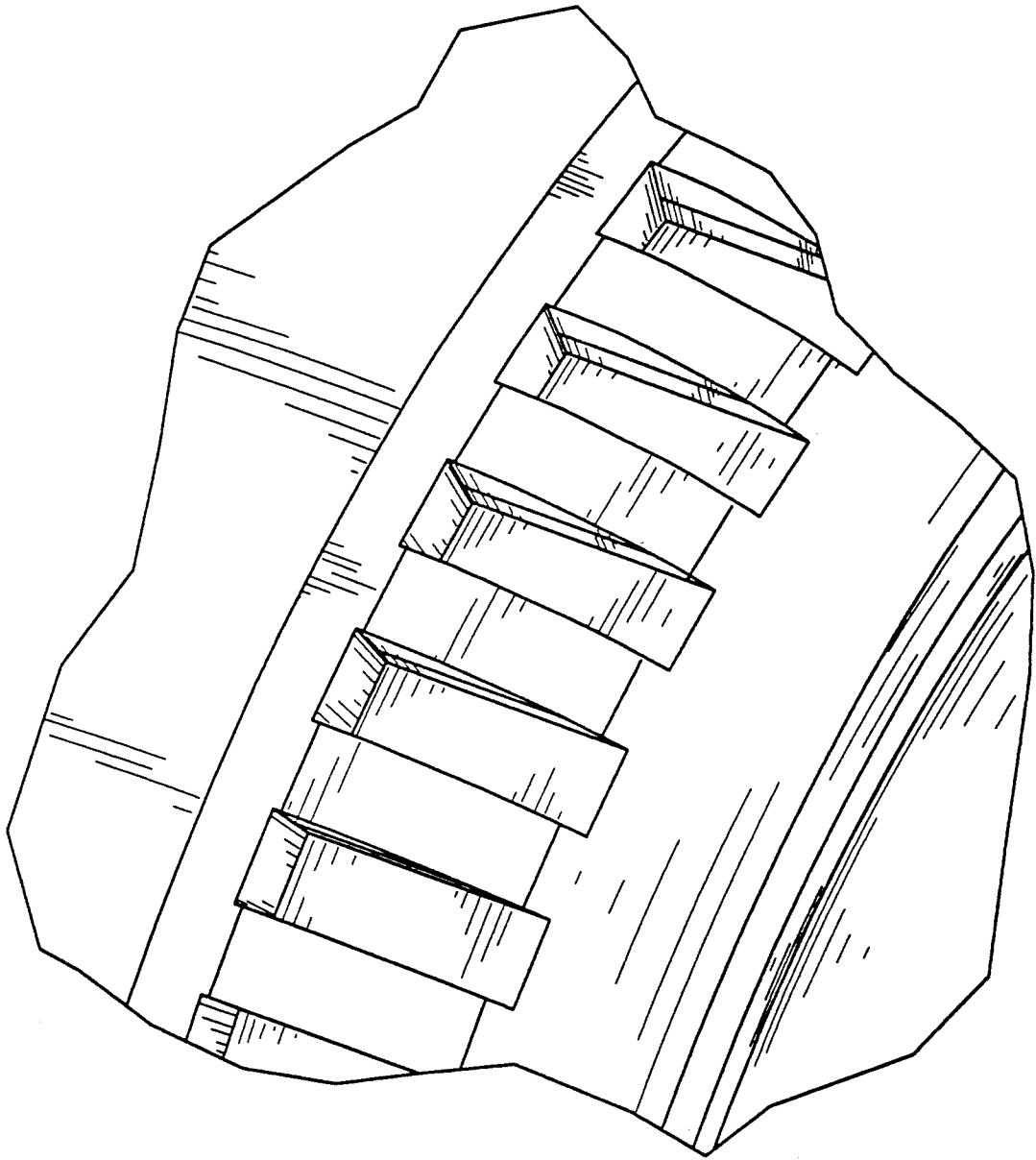

Fig.8

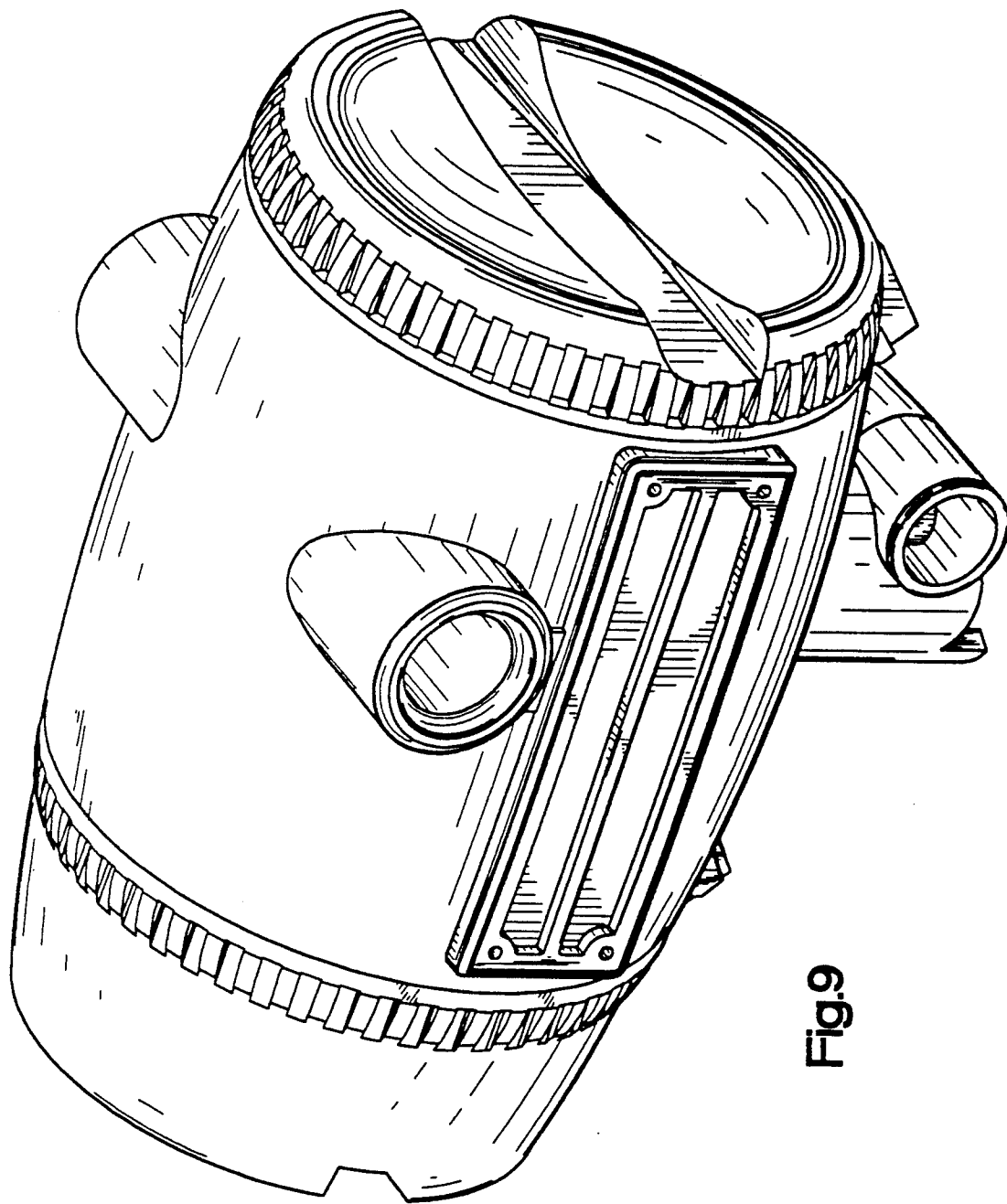

Fig. 9

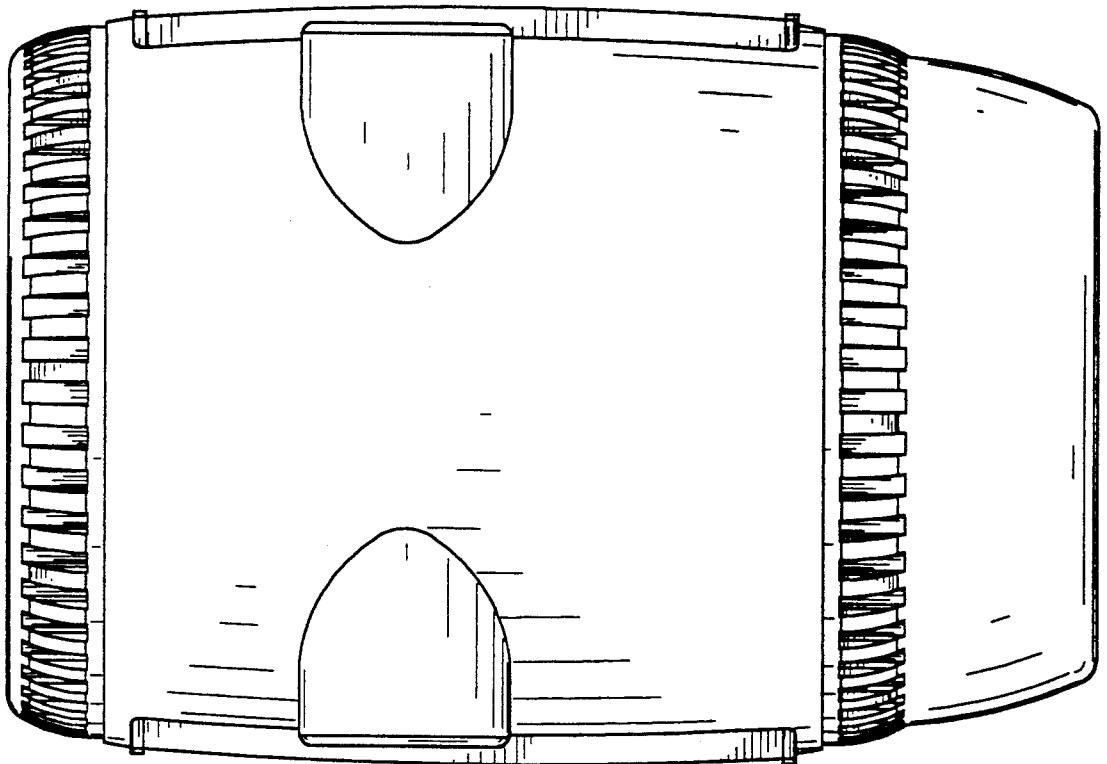

Fig.10

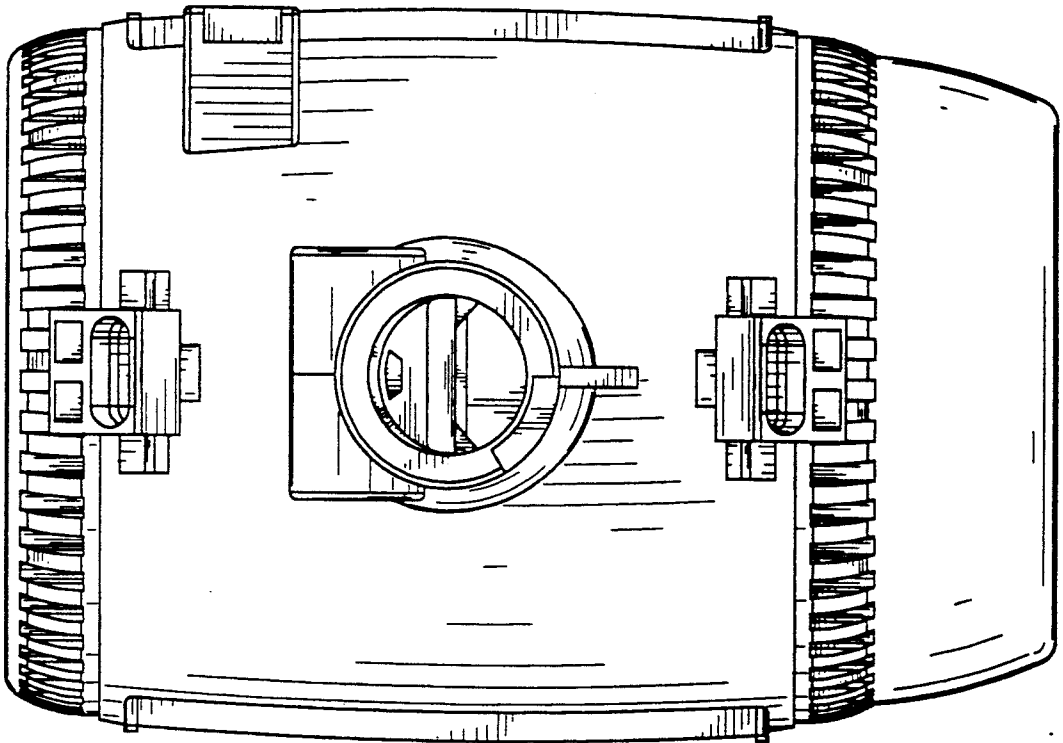

Fig.11

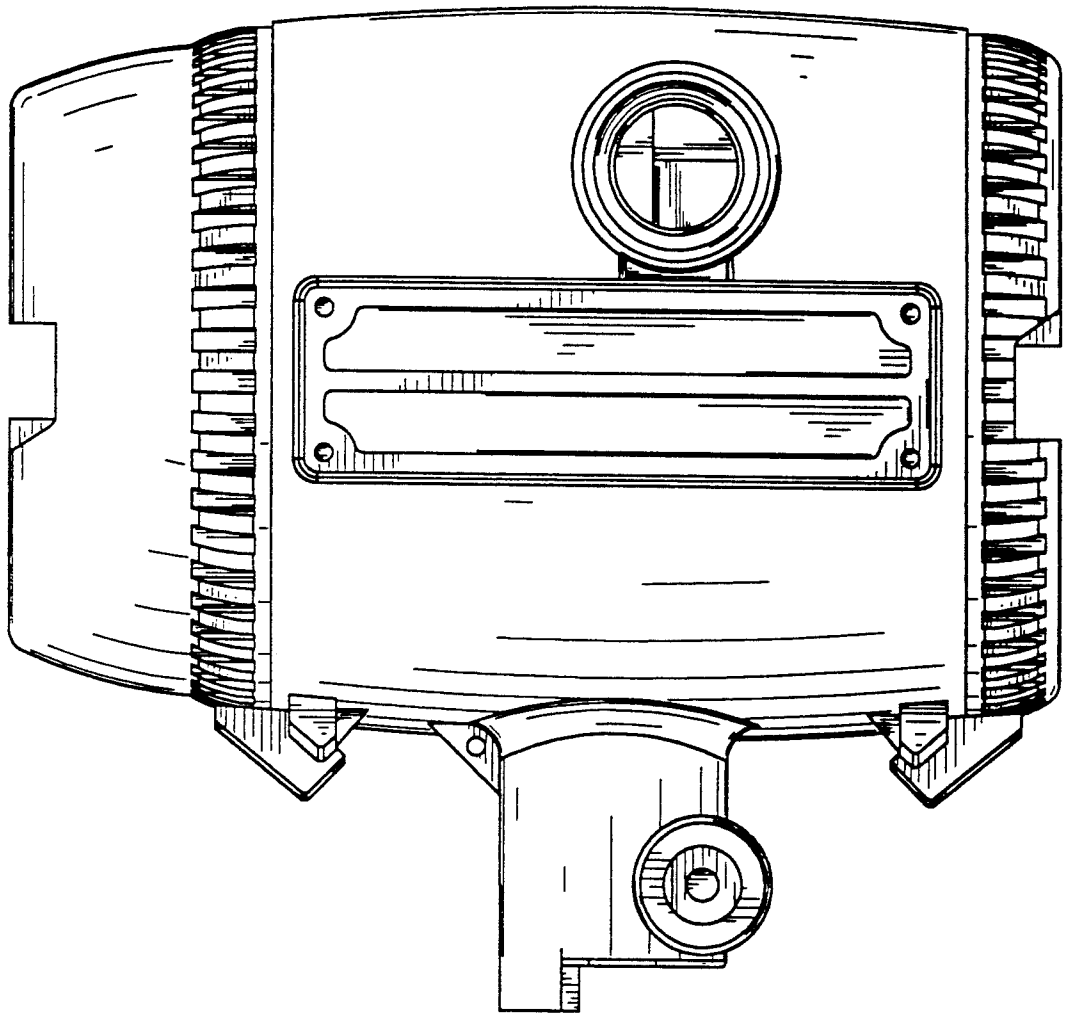

Fig.12

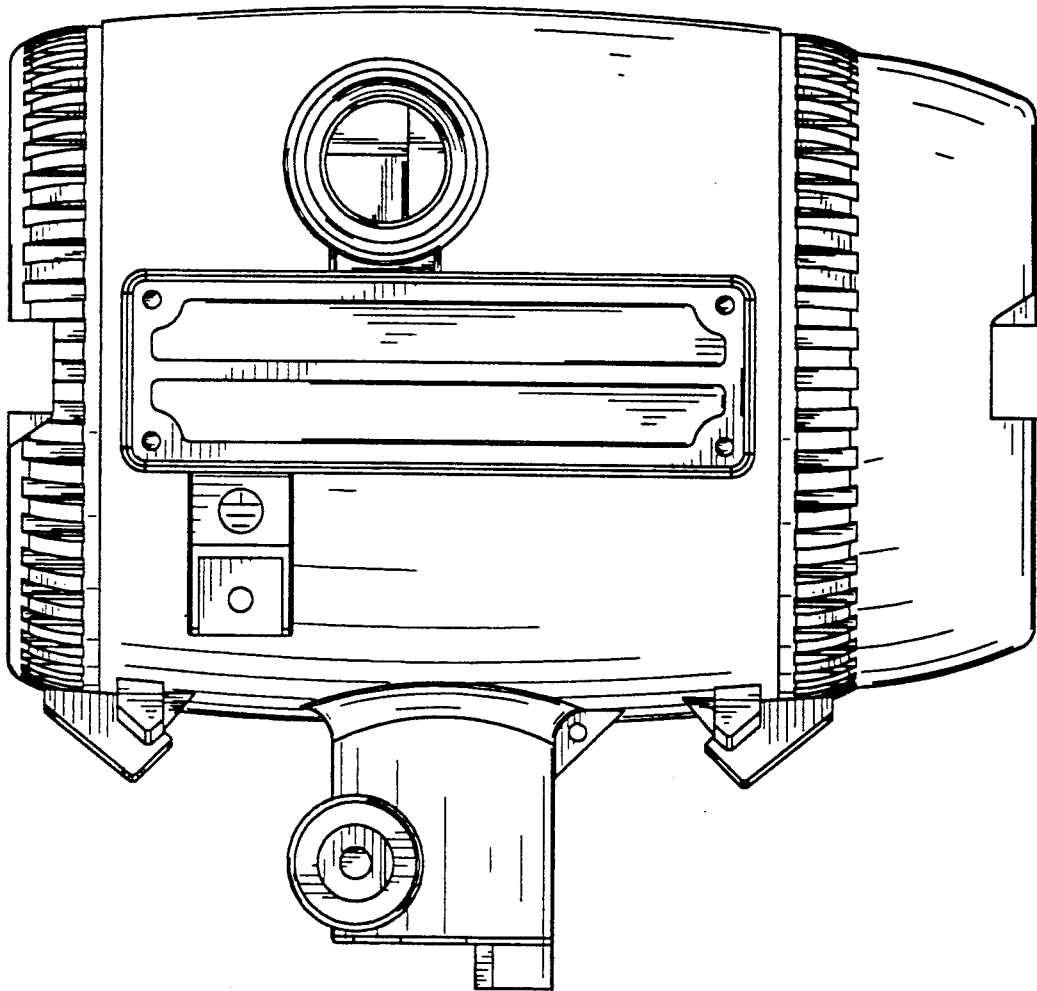

Fig.13

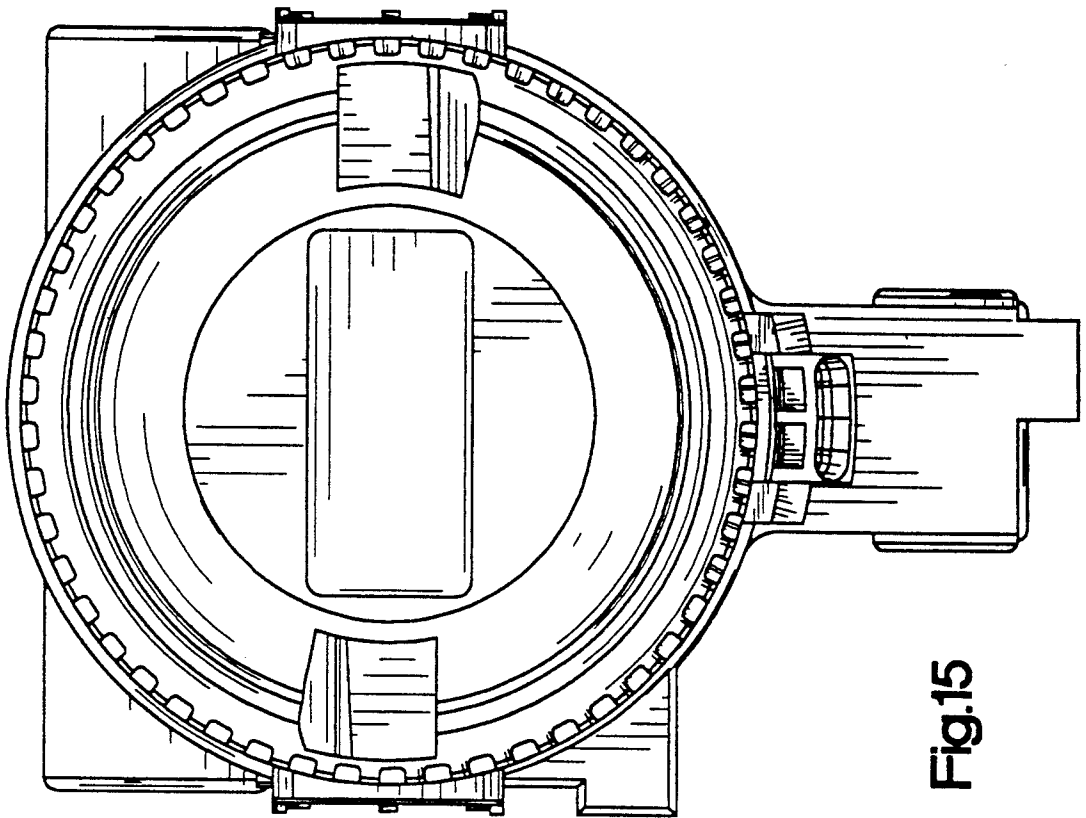

Fig.15

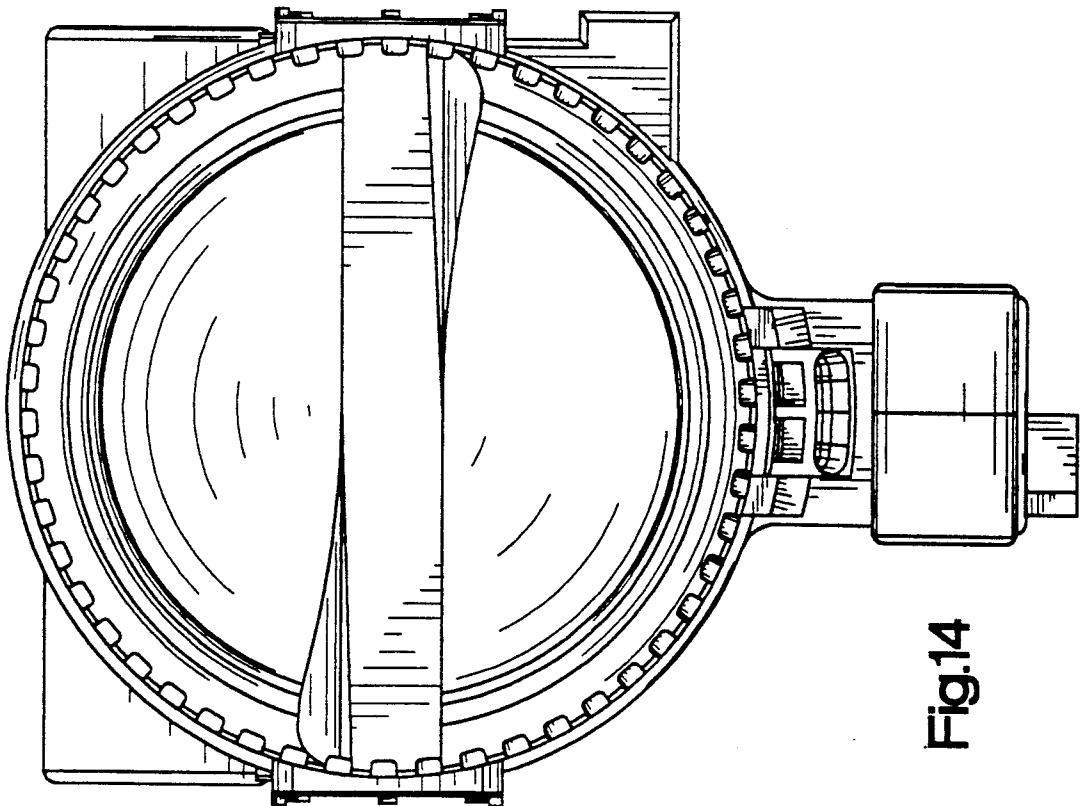

Fig.14