

Jan. 25, 1944.

R. E. CLARKE

2,339,979

DRYING APPARATUS

Original Filed Dec. 17, 1940 3 Sheets-Sheet 1

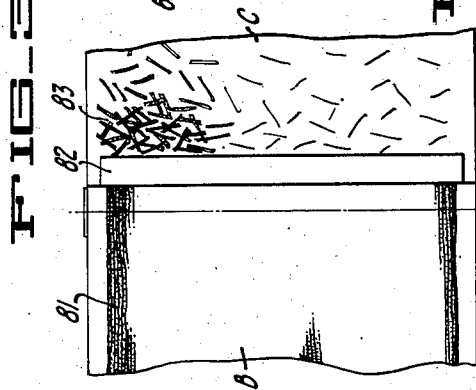
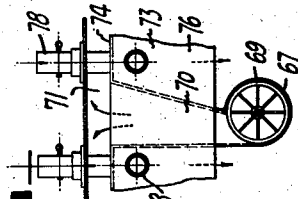
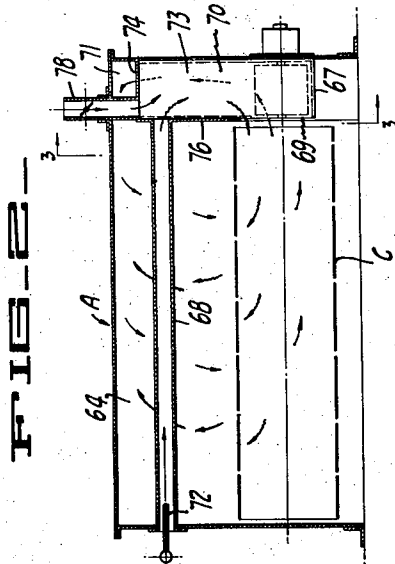
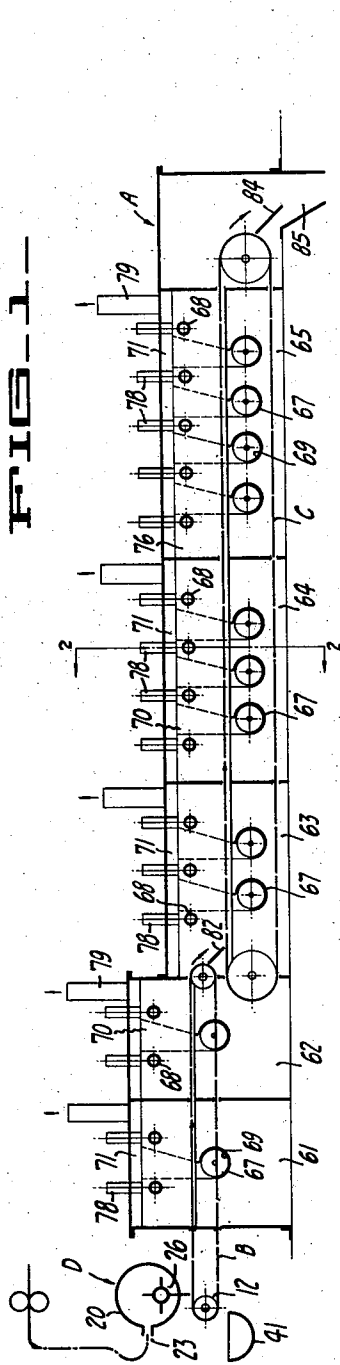

INVENTOR
Robert E. Clarke
BY
Paul D. Fecher
ATTORNEY

Jan. 25, 1944.

R. E. CLARKE

2,339,979

DRYING APPARATUS

Original Filed Dec. 17, 1940 3 Sheets-Sheet 2

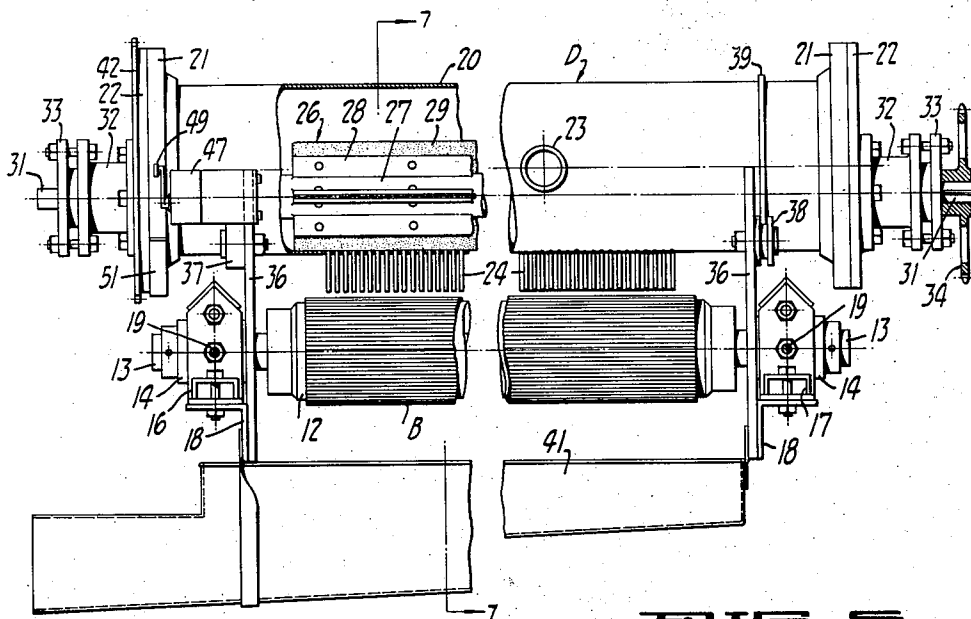

FIG. 5.

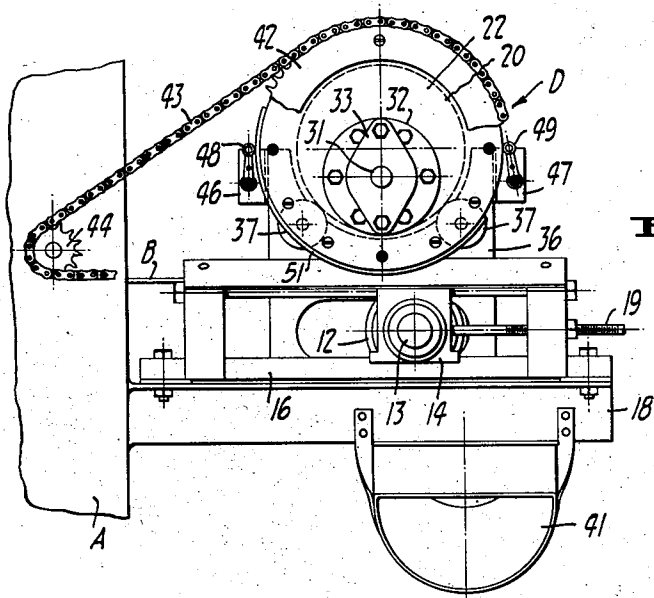

FIG. 6.

INVENTOR
Robert E. Clarke

BY
Paul D. Fisher
ATTORNEY

Jan. 25, 1944.

R. E. CLARKE

2,339,979

DRYING APPARATUS

Original Filed Dec. 17, 1940 3 Sheets-Sheet 3

FIG. 7-

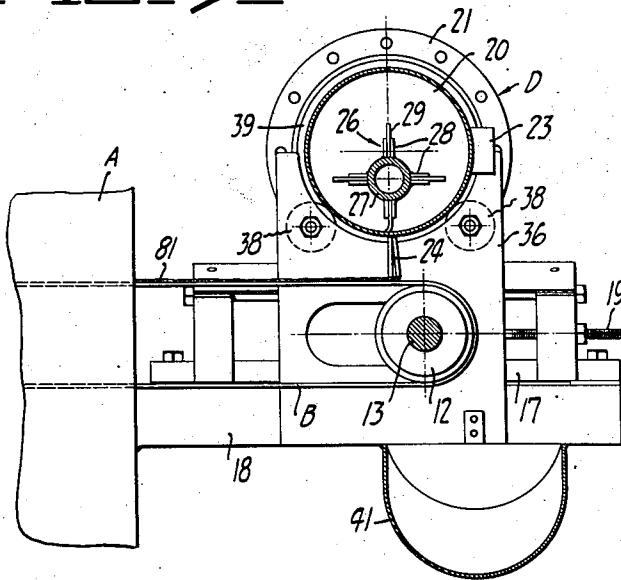

FIG. 8-

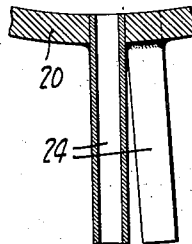

FIG. 9-

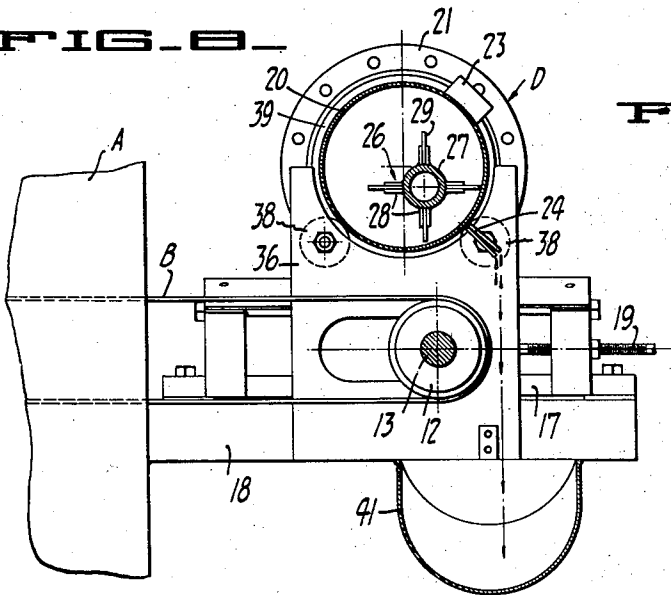
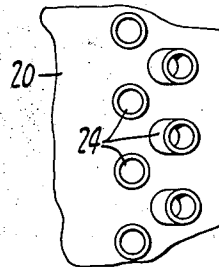

FIG. 10-



INVENTOR
Robert E. Clarke
BY
Paul D. Flehr
ATTORNEY

UNITED STATES PATENT OFFICE

2,339,979

DRYING APPARATUS

Robert E. Clarke, Palo Alto, Calif., assignor to Marine Magnesium Products Corporation, South San Francisco, Calif., a corporation of Delaware

Original application December 17, 1940, Serial No. 370,475. Divided and this application January 13, 1942, Serial No. 426,598

5 Claims. (Cl. 259-9)

This invention relates generally to drying apparatus applicable to the production of dry products from aqueous pastes or slurries. The invention has been advantageously applied to the drying of wet slurries of magnesium products, particularly slurries of magnesium carbonate and magnesium hydroxide.

It is an object of the invention to provide an improved form of drying apparatus of the above character, particularly with respect to the means employed for feeding the wet slurry to the drying belts.

A further object of the invention is to provide an improved form of feeder for drying apparatus, capable of distributing strings of a material like magnesium hydroxide or magnesium carbonate slurry, uniformly and continuously upon a drying belt.

Additional objects of the invention will appear from the following description in which the preferred embodiment has been set forth in detail in conjunction with the accompanying drawings. The present application is a division of my copending application, Serial No. 370,475, filed Dec. 17, 1940.

Referring to the drawings:

Fig. 1 is a side elevational view, in cross section, diagrammatically illustrating drying apparatus incorporating the present invention;

Fig. 2 is a cross sectional view on an enlarged scale taken along the line 2-2 of Fig. 1;

Fig. 3 is an enlarged detail taken along the line 3-3 of Fig. 2;

Fig. 4 is a plan view illustrating diagrammatically the manner in which the material is transferred from the preformer or preliminary drying belt to the main drying belt;

Fig. 5 is a side view, partly in cross section, showing the feeding apparatus which is incorporated with the drier;

Fig. 6 is an end view of the apparatus shown in Fig. 5;

Fig. 7 is a cross sectional detail taken along the line 7-7 of Fig. 5;

Fig. 8 is a view like Fig. 7 but showing the parts in a different operating position;

Fig. 9 is an enlarged cross sectional detail showing the discharge nozzles; and

Fig. 10 is a bottom plan view of the nozzles as shown in Fig. 9.

The complete drying apparatus diagrammatically illustrated in Figs. 1 to 4, inclusive, consists of a drying chamber A, which encloses the two drying belts B and C. The special feeding apparatus D supplies material to the belt B, and

partially dry solid material from this belt is transferred to belt C for final drying. The special feeding apparatus D is constructed to supply strings of slurry to the belt B, and these strings while being traversed by movement of the belt are dried a sufficient amount to form soluble and self-supporting sticks which are then deposited indiscriminately upon the belt C.

Figs. 5 to 10, inclusive, illustrate the details of the preferred type of special feeding apparatus. Referring particularly to Figs. 7 and 8, the exterior end of belt conveyor B is shown engaging the roller 12. Belt B, as well as belt C, can be formed of suitable material such as sections of woven wire netting. Roller 12 is shown mounted by having its ends provided with shaft extensions 13, engaged by the journal blocks 14. Guide tracks 16 and 17 slidably mount the journal blocks 14, and these tracks in turn are carried by the support members 18. Threaded rods 19 are attached to blocks 14 and facilitate making adjustments of the positioning of the blocks to secure proper tensioning of conveyor B.

In order to deliver paste to the upper run of the conveyor, I provide a chamber 20 which is conveniently in the form of a cylinder, and which extends horizontally across the conveyor. The ends of this chamber are provided with flanges 21 to which the end walls 22 are secured. The paste or slurry to be handled by the apparatus is applied to the interior of chamber 20 through two or more openings 23, which are distributed along the length of the chamber. In practice, a paste or slurry of material such as magnesium carbonate or magnesium hydroxide can be handled by a suitable form of positive displacement pump which has its discharge side connected to the inlet 23 through suitable flexible hose connections. As will be presently explained, flexible hose connections are desirable in order to make possible tilting movement of chamber 20.

The lower side of chamber 20 is provided with a plurality of discharge nozzles 24. It is desirable that each nozzle be in the form of a tube of suitable length, and it is also desirable to have the tubes staggered as shown in Fig. 10. In handling material like a magnesium carbonate slurry, it is satisfactory to utilize tubes about $2\frac{1}{2}$ inches long, and having an internal passage of about $\frac{3}{8}$ of an inch in diameter.

Within chamber 20 I provide means for forcing a relatively uniform flow of material through the several discharge nozzles. This means is preferably an agitator in the form of a wiper wheel 26, which consists of a tubular shaft 27, provided

with a plurality of circumferentially spaced vanes 28. The outer end portion 29 of these vanes are formed of flexible material such as strips of fabric reinforced vulcanized rubber.

For mounting agitator 26, the ends of the same have shaft extensions 31, which are carried by end journals 32. These journals are mounted upon the end plates 22, and are provided with suitable glands 33 to avoid leakage. Note (Fig. 7) that the axis of rotation of agitator 26 is eccentric with respect to the central axis of chamber 20. For the normal position of chamber 20, the axis of rotation is somewhat below the axis of the chamber, so that the flexible portions 29 engage the inner wall surface of the chamber in a region about the inlets of nozzle 24. In other words, these flexible elements wipe across the inlets of the nozzles as the agitator is rotated. One of the shaft extensions 31 is provided with a suitable sprocket wheel 34, which in turn is engaged by a suitable drive chain from a variable speed motor, for driving the wheel at a suitable rate. For different slurries, the rate of rotation may vary, as for example from 20 to 65 revolutions per minute.

For the normal position for the parts shown in Fig. 7 the nozzles 24 deliver material to the upper run of the conveyor. At certain times it is desirable to interrupt the supply of material to the conveyor, even though some material may continue to flow through the nozzles. To make this possible, I have provided a type of mounting for chamber 20, so that this chamber can be tilted to such a position that material flowing through the nozzles no longer is discharged upon the conveyor. Thus the supporting brackets 36 for the chamber 20 are provided with rollers 37 and 38, which support chamber 20, and thus permits the chamber to be tilted about its axis. To prevent longitudinal movement of the chamber, rollers 38 are shown provided with grooves engaged by the circular track 39. Tilting of chamber 20 to an angle of approximately 45° from the position shown in Fig. 7, is sufficient to transpose the nozzles 24 to a position as shown in Fig. 8, where material discharged from the nozzles falls past the ends of the conveyor, to be received by launder 41.

Instead of tilting chamber 20 by hand, it can be connected to a suitable tilting motor for remote operation. Thus as shown in Fig. 6, one end of chamber 20 can be provided with a sprocket 42 engaged by the chain 43. A smaller sprocket 44 engaged by chain 43 can connect to the shaft of a reversible electric motor. For automatically controlling this motor so that the chamber will be stopped automatically in either one of two operating positions, I have shown limiting switches 46 and 47 attached to the adjacent bracket 36, and each provided with trip rollers 48 and 49. A cam segment 51 is mounted upon the chamber adjacent the sprocket 42 and serves to engage the trip rollers 48 and 49 as the chamber is tilted from one position to another. Thus when current is supplied to the driving motor by closing a remote switch and when the chamber occupies the normal position of Fig. 7, the chamber tilts in a counterclockwise direction as viewed in Fig. 7, until the cam segment 51 contacts roller 49 of limiting switch 47, and then the supply of current to the motor is automatically interrupted with the chamber finally coming to rest in the position shown in Fig. 8. Upon again closing the circuit to the motor, the motor drives the chamber in a reverse direction so that the chamber finally comes to rest back in the position of Fig. 7.

Operation of the feeding apparatus described above can be reviewed as follows: Assuming that the parts are positioned as shown in Fig. 7, and that the conveyor belt is operating at a predetermined speed, the material to be dried is pumped to the chamber 20 through the openings 23. Initially there will be insufficient pressure to force any appreciable amount of material through the nozzles 24. However, as the level of the material within the chamber 20 rises, the trapped air above this material is placed under pressure, and this pressure in turn tends to force more material through the nozzles 24. By adjusting the rate at which the material is pumped to the chamber, the level of the material within the chamber can be adjusted to a value desired, so that there is a pressure within the chamber adequate for feeding the material at the desired rate through the nozzles. For example, when handling an aqueous slurry of magnesium carbonate containing about 12 to 15% magnesium carbonate, the chamber can be maintained about ¾ full, with an internal pressure of about 0.5 pound per square inch. Air at higher pressures can be supplied to the upper portion of the chamber to force thicker material through the nozzles.

The agitator 26 is driven at a constant rate, as for example 34 revolutions per minute, in handling magnesium carbonate slurry. As the wheel rotates, it performs several functions, all of which aid in securing the results desired. It serves to recurrently wipe off the entrance or inlets of the nozzles, and thus prevents these nozzles from becoming clogged by removing any lumpy material which may be about ready to enter the nozzles. It also serves to repeatedly mix the body of material within the chamber, thus aiding in securing uniformity of material discharged through the nozzles, in the event that concentration of the material supplied to the chamber varies from time to time. It also causes the material within the chamber to be repeatedly carried upwardly and over the wheel, thus serving to prevent short circuiting of material entering the chamber, to the nozzles adjacent the point of entrance, and also aiding in securing thorough intermixture with resulting uniformity.

As disclosed in said co-pending application Serial No. 370,475, as the material is discharged from nozzles 24 it is carried away upon the upper run of the conveyor B in the form of a series of parallel strings. The speed of the conveyor is adjusted in order to prevent the strings from becoming too thick or too thin. Strings which are too thick make for inefficient drying and may cause adjacent strings to contact and merge together. Strings which are too thin make for inefficient operation of the drier and seriously reduce the capacity of the equipment. When it is desired to interrupt the supply of material to the conveyor belt, as for example at the end of a run, one simply tilts the chamber to the position shown in Fig. 8 so that material flowing out through the nozzles 24 drips down into launder 41.

The remaining structural features of the dryer have been disclosed in my aforesaid co-pending application, Serial No. 370,475. Briefly, the drying chamber enclosing conveyor B is divided into compartments 61 and 62. The remainder of the chamber enclosing conveyor C is divided into compartments 63, 64 and 65. Each compartment is provided with circulating blowers or fans 67 and with heaters 68 which can utilize suit-

able fuel gas. Each circulating fan (Figs. 2 and 3) has its inlet opening 69 communicating with the space below the upper run of conveyor C at one side of the drying chamber, and a short discharge conduit 70 extends upwardly from the blower and discharges into the side space 71, from which the drying gas flows outwardly and downwardly over the heaters 68. Each heater 68 is in the form of a tube or metal conduit with one end communicating through the side wall of the drying chamber and provided with a burner 72. The other end of the burner unit is in communication with space 73 which is isolated from the main space of the drying chamber by the horizontal and vertical walls 74 and 76. Below the lower edge of wall 76, space 73 communicates with the space below the upper run of the conveyor belt (Fig. 2). A flue pipe 78 provided with a valve or damper, communicates with space 73 and makes possible the drawing in of a controlled amount of atmospheric air. Exhaust pipe 79 communicates between the exterior and space 71 to permit the continual exhaust of moisture-laden air to the atmosphere.

To review operation of the apparatus as a whole, it will be presumed that one wishes to dry an aqueous slurry of basic magnesium carbonate containing about 13% solids. The feeding apparatus D is operated as previously described to discharge parallel strings of the slurry upon the upper run of the conveyor belt B, substantially as shown at 81 in Fig. 4. While being transferred through the compartments 61 and 62, these strings of wet material are contacted with the drying gas so that the moisture content is reduced to such an extent that the strings become relatively solid and friable. Various temperatures can be used, as for example a drying gas temperature in compartments 61 and 62 of from 350 to 400° F. The material mentioned is sufficiently solid and friable to transfer to belt C when the solids content is increased to about 25%.

At the inner discharge end of conveyor B, the strings break into self supporting sticks of material which are dropped and piled indiscriminately upon the upper run of conveyor C. Scraper 82 can be employed to aid proper discharge upon conveyor B. Conveyor C is operated at a relatively slow speed compared to conveyor B, as for example conveyor B can be about 25 feet long and can travel at about 15 feet per minute, while conveyor C can be about 60 feet long and can travel at a speed of about 1 foot per minute. Thus the sticks of material 83 are piled upon the upper run of conveyor C to form a bed of considerable depth through which the drying gas may circulate (Fig 4).

When the material is delivered from the end of the conveyor C, its moisture content has been reduced to the value desired. At this discharge end a suitable scraper blade 84 can be provided, and the material can be delivered through the discharge chute 85. The dried material can then be ground to form a powdered product of the desired fineness.

I claim:

1. An apparatus for continuously feeding strings of a thick slurry upon a receiving surface, a closed horizontally extending chamber positioned over said surface, a series of discharge nozzles along the underside of the chamber, means for supplying slurry under pressure to the chamber to maintain a body of slurry of sub-

stantial depth within the chamber overlying the discharge nozzles and to maintain air under pressure above said body, means for agitating the slurry in said chamber and aiding flow of slurry through the nozzle, said means comprising a plurality of rotatable wiping elements within the chamber for wiping over the inlets to said nozzles, and means for rocking the chamber together with said agitating means to displace said nozzles from a position for discharge of material on said surface to a second position in which the material is discharged off of said surface.

2. An apparatus for continuously feeding strings of a paste or thick slurry upon a receiving surface, a closed cylindrical horizontally extending chamber positioned over said surface adapted to receive the paste, a plurality of discharge nozzles communicating through the underside of the chamber, means for supplying said paste to said chamber under pressure to provide a body of said paste of substantial depth over said nozzles and to maintain air under pressure above said body, a wiper wheel rotatably disposed within the chamber for agitating said paste and aiding flow of said paste through said nozzles, the wiper wheel having an axis of rotation disposed below the longitudinal axis of the chamber, said wiper wheel being provided with a plurality of flexible wiping elements for contacting and wiping over a segmental portion of the chamber wall through which said nozzles communicate, and means for mounting said chamber for rocking movement about its axis to displace said nozzles from a position for discharge of material on said surface to a second position in which the material is discharged off of said surface.

3. An apparatus for continuously feeding strings of a thick slurry upon a conveyor or belt, a closed elongated chamber extending horizontally over one end of the conveyor, a series of discharge nozzles along the underside of the chamber, means for supplying slurry under pressure to the chamber to provide a body of said slurry of substantial depth within the chamber overlying the discharge nozzles with a space above said body containing air under pressure greater than atmospheric, means for agitating the slurry in said chamber and aiding substantially continuous and uniform flow of slurry through the nozzles, said means comprising a plurality of rotatable wiping elements disposed within the chamber for wiping over the inlets of said nozzles, and means for rocking the chamber together with said agitating means to displace said nozzles for discharging material beyond said end of said conveyor.

4. An apparatus for continuously feeding strings of a thick slurry upon a conveyor, an elongated chamber extending horizontally over one end of the conveyor for receiving said slurry, a series of discharge nozzles communicating through one side of the chamber, rotatable wiping and agitating means within the chamber for aiding flow of slurry through the nozzles, journal means for said wiping means secured to end walls of the chamber and means for rocking the chamber together with said wiping means to displace said nozzles for discharging material beyond said end of the conveyor.

5. An apparatus for feeding strings of a thick slurry upon a receiving surface, a cylindrical shaped chamber for receiving said slurry extending horizontally over said surface, said chamber having end walls, a plurality of nozzles communi-

cating through one side of said chamber, wiping and agitating means within the chamber for aiding flow of slurry through the nozzles, said wiping means having an axis of rotation eccentric with respect to the longitudinal axis of the chamber, journal means on said end walls for said wiper means, and means for mounting said

chamber for rocking movement about its axis to displace said nozzles from a position for discharge of material on said surface to a second position in which the material is discharged off of said surface.

ROBERT E. CLARKE.