



(51) International Patent Classification:

F21V 21/35 (2006.01) F21S 8/02 (2006.01)
H01R 25/14 (2006.01) F21V 21/04 (2006.01)
F21V 21/30 (2006.01) F21S 8/06 (2006.01)

(21) International Application Number:

PCT/IL2016/050189

(22) International Filing Date:

17 February 2016 (17.02.2016)

(25) Filing Language:

English

(26) Publication Language:

English

(30) Priority Data:

62/117,021 17 February 2015 (17.02.2015) US

(71) Applicant: **CHOCOLATE LIGHTING COMPANY LTD** [IL/IL]; 55 Nordau Street, 4658215 Herzlia B (IL).

(72) Inventor: **TUCHLER, Gideon**; 46 Nordau Street, 4658206 Herzlia B (IL).

(74) Agents: **EHRlich, Gal** et al.; G.E. EHRlich (1995) LTD., 11 Menachem Begin Road, 5268104 Ramat Gan (IL).

(81) Designated States (unless otherwise indicated, for every kind of national protection available): AE, AG, AL, AM,

AO, AT, AU, AZ, BA, BB, BG, BH, BN, BR, BW, BY, BZ, CA, CH, CL, CN, CO, CR, CU, CZ, DE, DK, DM, DO, DZ, EC, EE, EG, ES, FI, GB, GD, GE, GH, GM, GT, HN, HR, HU, ID, IL, IN, IR, IS, JP, KE, KG, KN, KP, KR, KZ, LA, LC, LK, LR, LS, LU, LY, MA, MD, ME, MG, MK, MN, MW, MX, MY, MZ, NA, NG, NI, NO, NZ, OM, PA, PE, PG, PH, PL, PT, QA, RO, RS, RU, RW, SA, SC, SD, SE, SG, SK, SL, SM, ST, SV, SY, TH, TJ, TM, TN, TR, TT, TZ, UA, UG, US, UZ, VC, VN, ZA, ZM, ZW.

(84) Designated States (unless otherwise indicated, for every kind of regional protection available): ARIPO (BW, GH, GM, KE, LR, LS, MW, MZ, NA, RW, SD, SL, ST, SZ, TZ, UG, ZM, ZW), Eurasian (AM, AZ, BY, KG, KZ, RU, TJ, TM), European (AL, AT, BE, BG, CH, CY, CZ, DE, DK, EE, ES, FI, FR, GB, GR, HR, HU, IE, IS, IT, LT, LU, LV, MC, MK, MT, NL, NO, PL, PT, RO, RS, SE, SI, SK, SM, TR), OAPI (BF, BJ, CF, CG, CI, CM, GA, GN, GQ, GW, KM, ML, MR, NE, SN, TD, TG).

Published:

- with international search report (Art. 21(3))
- before the expiration of the time limit for amending the claims and to be republished in the event of receipt of amendments (Rule 48.2(h))

(54) Title: TRACK LIGHTING SYSTEM

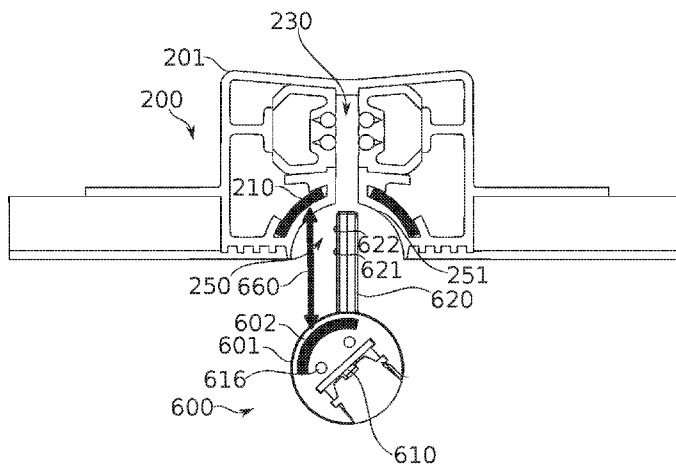

FIG. 5C

(57) Abstract: A system comprising track-mounted luminaires and track. In some embodiments, electrical power for illumination is accessed by a luminaire through electrified railing recessed within a relatively narrow slot of the track. In some embodiments, mounting means are provided separately from and/or additional to the power slot, comprising, for example, a magnetic mount. Optionally luminaires are orientable to select a direction of illumination, while secured by the magnetic mount. The track is optionally mounted flush and/or recessed with a mounting surface such as a ceiling and/or wall. In some embodiments, a recessed surface of the track is formed with an arc. Optionally luminaires conform with the curvature of the arc. Additionally or alternatively, the track is at least partially masked and/or decorated, for example by plastering and/or a face plate.



TRACK LIGHTING SYSTEM

RELATED APPLICATIONS

This application claims the benefit of priority under 35 USC §119(e) of U.S. Provisional Patent Application No. 62/117,021 filed February 17, 2015, the contents of which are incorporated herein by reference in their entirety.

FIELD AND BACKGROUND OF THE INVENTION

The present invention, in some embodiments thereof, relates to the field of artificial illumination systems and more particularly, to systems for track lighting.

Track lighting systems provide means of selectably positioning and/or directing illumination; for example, according to the particular needs of an illuminated space. A typical track lighting system comprises track and luminaire components. Tracks support power distribution to and mechanical mounting of one or more luminaires at a plurality of positions (usually continuously) along their extent. Luminaires convert power to illumination, including determination of illumination parameters such as intensity, directionality, angle of spread and/or color.

Once mounted, track lighting systems allow flexibility in determining lighting conditions, and optionally allow changes according to changes in requirements. For example, luminaires are moveable along the track and/or re-orientable relative to the track. In some track lighting systems, luminaires attached to the track can be removed, added, and/or exchanged according to need.

The visual impact of the lighting system overall comprises the light provided, but also the appearance of the track, the luminaires, and their integration with their surroundings when mounted to a ceiling, wall, and/or other support member.

SUMMARY OF THE INVENTION

According to an aspect of some embodiments of the present invention, there is provided a track lighting track comprising a luminaire mounting surface having a concavity extending along an elongate track housing; wherein the concavity has an inset arcuate profile transverse to the track housing length, and wherein the inset arcuate profile is interrupted by an opening of a slot, also extending along the length of the track housing, which is further inset from the inset arcuate profile.

According to some embodiments of the invention, the slot is 8 mm or less in width.

According to some embodiments of the invention, the inset arcuate profile comprises an arc of a circle.

5 According to some embodiments of the invention, the track comprises a curved wall extending along the track and defining a surface of the inset arcuate profile; wherein a magnetically attracted material lines the curved wall.

According to some embodiments of the invention, the magnetically attracted material lines the curved wall on a side of the curved wall opposite the surface of the inset arcuate profile.

10 According to some embodiments of the invention, the track is configured for recessed mounting relative to a mounting surface of an architectural space.

According to some embodiments of the invention, the track comprises lateral mounting flanges receded by a distance from the mounting surface of the track about equal to the thickness of a standard mounting board.

15 According to some embodiments of the invention, the distance is sufficiently larger than the thickness of standard mounting board to receive a coating of material blending the appearance of the mounting surface of the track with an exposed surface of a mounting board when mounted thereat.

20 According to some embodiments of the invention, the slot includes at least one electrical conductor positioned to receive a contact from a power contact assembly of a luminaire and deliver electrical power therethrough.

According to some embodiments of the invention, the slot includes a region configured to receive and support weight of a luminaire, wherein the weight is transferred to the region through the power contact assembly.

25 According to some embodiments of the invention, the track includes at least one luminaire having a fixation portion with a convex arcuate profile that fittingly inserts to the concavity.

30 According to some embodiments of the invention, the fixation portion includes a power contact assembly configured to insert into the slot to receive electrical power therefrom.

According to some embodiments of the invention, the track includes at least one luminaire having a fixation portion which inserts to the concavity; the fixation portion including a material magnetically attracted to the magnetically attracted material lining the curved wall; and the magnetic attraction being sufficient to support at least 75% of the weight of the luminaire.

According to some embodiments of the invention, the magnetic attraction is between materials separated by at least 2 mm.

According to some embodiments of the invention, the magnetic attraction is between materials separated by at least a wall or ceiling surfacing material.

According to some embodiments of the invention, the magnetic attraction is between materials separated by at least a 2 mm thickness of aluminum.

According to some embodiments of the invention, the fixation portion of the luminaire is sized to fit inside the concavity; wherein a flat surface of the fixation portion is substantially flush to the mounting surface adjoining the concavity.

According to some embodiments of the invention, a housing of an illuminating module of the luminaire is sized to fittingly insert to the concavity when the fixation portion of the luminaire is inserted to the concavity; the orientation of the illuminating module relative to a longitudinal axis of the track being configurable from a plurality of orientations.

According to an aspect of some embodiments of the present invention, there is provided a track lighting system comprising: an elongate track housing; and a luminaire having a fixation portion configured for magnetic mounting to the track housing; wherein: the fixation portion includes a material magnetically attracted to a magnetically attracted material of the track housing, closest surfaces of the magnetically attracted materials of the track housing and the luminaire are separated by at least 2 mm when the luminaire is mounted to the track housing, and the magnetic attraction between the separated magnetically attracted materials is sufficient to support at least 75% of the weight of the luminaire.

According to some embodiments of the invention, the magnetic attraction is between materials separated by at least a wall or ceiling surfacing material.

According to some embodiments of the invention, the magnetic attraction is between materials separated by at least a 2 mm thickness of aluminum.

According to an aspect of some embodiments of the present invention, there is provided a luminaire for use with a track lighting system comprising: a housing having a convex track mounting surface comprising an arcuate cross-section; the luminaire also comprising a power contact assembly protruding from the convex mounting surface.

5 According to some embodiments of the invention, the power contact assembly is 8 mm wide or less.

 According to some embodiments of the invention, the power contact assembly is 5 mm wide or less.

10 According to some embodiments of the invention, the power contact assembly is 3 mm wide or less.

 According to an aspect of some embodiments of the present invention, there is provided a luminaire for use with a track lighting track, including a power contact assembly comprising a housing and at least one electrode having a tensioning means, the tensioning means being compressed by the housing, and a portion of the electrode
15 being urged outward from the housing by the tensioning means; wherein the power contact assembly is sized to fit within a slot aperture extending along a track.

 According to some embodiments of the invention, the slot aperture is 5 mm wide or less.

20 According to an aspect of some embodiments of the present invention, there is provided a track lighting track comprising: an elongate track housing; a slot in and extending along the housing, the slot including at least one electrical conductor positioned to receive a contact from a power contact assembly of a luminaire and deliver electrical power therethrough; wherein an aperture of the slot through which the power contact assembly is received is 8 mm wide or less along at least 90% of the track
25 housing.

 According to some embodiments of the invention, the aperture is 5 mm wide or less.

 According to some embodiments of the invention, the aperture is 3 mm wide or less.

30 According to some embodiments of the invention, the aperture is 1 mm wide or less.

According to some embodiments of the invention, the housing is mounted along an exposed surface of an architectural space, such that the only portion of the housing visible from within the architectural space is the slot.

According to some embodiments of the invention, the track comprises a means
5 for supporting the weight of a luminaire, wherein the support means is concealed behind the exposed surface.

According to some embodiments of the invention, the support means provides support by magnetic attraction to a luminaire.

According to some embodiments of the invention, a means for supporting the
10 weight of a luminaire is located within the slot at a position where it contacts a portion of the power contact assembly.

According to an aspect of some embodiments of the present invention, there is provided a luminaire for a track lighting system comprising: a plurality of locking members offset from each other along the length of a mounting assembly, wherein the
15 locking members are sized, shaped and sufficiently flexible for fittingly passing into a slot of a track 5 mm wide or less; each locking member comprising a surface which lockingly engages one wall of the slot upon complete insertion into the slot; and wherein at least two of the plurality of locking members engage opposite walls upon the insertion to resist extraction from the slot by a force of the weight of the luminaire.

According to some embodiments of the invention, the region of locking
20 engagement comprises a surface sloped toward the opening of the slot as the sloped surface approaches the slot.

According to some embodiments of the invention, the slope of the sloped surface is angled to translate force operating to pull the luminaire free of the slot into a
25 lateral motion of the lockingly engaging surface, and wherein a force with which the lockingly engaging surface resists the lateral motion is overcome to free the engaging surface of engagement with the wall of the slot when the pulling force is about three times larger than the force of the weight of the luminaire on the locking member.

According to some embodiments of the invention, the region of locking
30 engagement comprises a surface which retains the locking member by friction.

According to an aspect of some embodiments of the present invention, there is provided a method of mounting and unmounting a luminaire to a track lighting system

comprising: pushing a luminaire straight into a slot of a track, thereby locking the luminaire in place; pulling a luminaire in a direction straight outward from the slot, thereby releasing the luminaire from the locking; and extracting the unlocked luminaire the rest of the way out of the slot.

5 According to some embodiments of the invention, the pulling is with a force of between three to five times the force of the weight of the luminaire.

 According to an aspect of some embodiments of the present invention, there is provided a track lighting system comprising: an elongated track; and a luminaire having a luminous element located at a longitudinal position along the track when the luminaire
10 is coupled to the track; wherein the luminaire comprises at least one magnet magnetically attracted to a material of the track; and wherein the magnet is located at the longitudinal position, and within 10 mm of the luminous element.

 Unless otherwise defined, all technical and/or scientific terms used herein have the same meaning as commonly understood by one of ordinary skill in the art to which
15 the invention pertains. Although methods and materials similar or equivalent to those described herein can be used in the practice or testing of embodiments of the invention, exemplary methods and/or materials are described below. In case of conflict, the patent specification, including definitions, will control. In addition, the materials, methods, and examples are illustrative only and are not intended to be necessarily limiting.

20 As will be appreciated by one skilled in the art, aspects of the present invention may be embodied as a system, method or computer program product. Accordingly, aspects of the present invention may take the form of an entirely hardware embodiment, an entirely software embodiment (including firmware, resident software, micro-code, etc.) or an embodiment combining software and hardware aspects that may all generally
25 be referred to herein as a “circuit,” “module” or “system.” Furthermore, aspects of the present invention may take the form of a computer program product embodied in one or more computer readable medium(s) having computer readable program code embodied thereon. Implementation of the method and/or system of embodiments of the invention can involve performing or completing selected tasks manually, automatically, or a
30 combination thereof. Moreover, according to actual instrumentation and equipment of embodiments of the method and/or system of the invention, several selected tasks could

be implemented by hardware, by software or by firmware or by a combination thereof using an operating system.

For example, hardware for performing selected tasks according to embodiments of the invention could be implemented as a chip or a circuit. As software, selected tasks
5 according to embodiments of the invention could be implemented as a plurality of software instructions being executed by a computer using any suitable operating system. In an exemplary embodiment of the invention, one or more tasks according to exemplary embodiments of method and/or system as described herein are performed by a data processor, such as a computing platform for executing a plurality of instructions.
10 Optionally, the data processor includes a volatile memory for storing instructions and/or data and/or a non-volatile storage, for example, a magnetic hard-disk and/or removable media, for storing instructions and/or data. Optionally, a network connection is provided as well. A display and/or a user input device such as a keyboard or mouse are optionally provided as well.

15 Any combination of one or more computer readable medium(s) may be utilized. The computer readable medium may be a computer readable signal medium or a computer readable storage medium. A computer readable storage medium may be, for example, but not limited to, an electronic, magnetic, optical, electromagnetic, infrared, or semiconductor system, apparatus, or device, or any suitable combination of the
20 foregoing. More specific examples (a non-exhaustive list) of the computer readable storage medium would include the following: an electrical connection having one or more wires, a portable computer diskette, a hard disk, a random access memory (RAM), a read-only memory (ROM), an erasable programmable read-only memory (EPROM or Flash memory), an optical fiber, a portable compact disc read-only memory (CD-ROM),
25 an optical storage device, a magnetic storage device, or any suitable combination of the foregoing. In the context of this document, a computer readable storage medium may be any tangible medium that can contain, or store a program for use by or in connection with an instruction execution system, apparatus, or device.

A computer readable signal medium may include a propagated data signal with
30 computer readable program code embodied therein, for example, in baseband or as part of a carrier wave. Such a propagated signal may take any of a variety of forms, including, but not limited to, electro-magnetic, optical, or any suitable combination

thereof. A computer readable signal medium may be any computer readable medium that is not a computer readable storage medium and that can communicate, propagate, or transport a program for use by or in connection with an instruction execution system, apparatus, or device.

5 Program code embodied on a computer readable medium may be transmitted using any appropriate medium, including but not limited to wireless, wireline, optical fiber cable, RF, etc., or any suitable combination of the foregoing.

 Computer program code for carrying out operations for aspects of the present invention may be written in any combination of one or more programming languages, including an object oriented programming language such as Java, Smalltalk, C++ or the like and conventional procedural programming languages, such as the "C" programming language or similar programming languages. The program code may execute entirely on the user's computer, partly on the user's computer, as a stand-alone software package, partly on the user's computer and partly on a remote computer or entirely on the remote computer or server. In the latter scenario, the remote computer may be connected to the user's computer through any type of network, including a local area network (LAN) or a wide area network (WAN), or the connection may be made to an external computer (for example, through the Internet using an Internet Service Provider).

 Aspects of the present invention are described below with reference to flowchart illustrations and/or block diagrams of methods, apparatus (systems) and computer program products according to embodiments of the invention. It will be understood that each block of the flowchart illustrations and/or block diagrams, and combinations of blocks in the flowchart illustrations and/or block diagrams, can be implemented by computer program instructions. These computer program instructions may be provided to a processor of a general purpose computer, special purpose computer, or other programmable data processing apparatus to produce a machine, such that the instructions, which execute via the processor of the computer or other programmable data processing apparatus, create means for implementing the functions/acts specified in the flowchart and/or block diagram block or blocks.

 These computer program instructions may also be stored in a computer readable medium that can direct a computer, other programmable data processing apparatus, or other devices to function in a particular manner, such that the instructions stored in the

computer readable medium produce an article of manufacture including instructions which implement the function/act specified in the flowchart and/or block diagram block or blocks.

The computer program instructions may also be loaded onto a computer, other
5 programmable data processing apparatus, or other devices to cause a series of operational steps to be performed on the computer, other programmable apparatus or other devices to produce a computer implemented process such that the instructions which execute on the computer or other programmable apparatus provide processes for implementing the functions/acts specified in the flowchart and/or block diagram block
10 or blocks.

BRIEF DESCRIPTION OF THE SEVERAL VIEWS OF THE DRAWINGS

Some embodiments of the invention are herein described, by way of example only, with reference to the accompanying drawings. With specific reference now to the drawings in detail, it is stressed that the particulars shown are by way of example, and
15 for purposes of illustrative discussion of embodiments of the invention. In this regard, the description taken with the drawings makes apparent to those skilled in the art how embodiments of the invention may be practiced.

In the drawings:

FIG. 1A is a schematic perspective view of a track for a recessed track lighting
20 system comprising a narrow power access slot and a magnetically attracted mounting strip; for power delivery and mechanical support, respectively, of a luminaire, according to some exemplary embodiments of the invention;

FIG. 1B is a partially exploded schematic perspective view of the track of
Figure 1A, according to some exemplary embodiments of the invention;

25 FIG. 2 is a partially exploded schematic view of a contact assembly, according to some exemplary embodiments of the invention;

FIG. 3A is a schematic perspective view of a track for a recessed track lighting system, comprising a narrow power access slot and magnetically attracted mounting plates shaped to accommodate an arcuately profiled inset, according to some exemplary
30 embodiments of the invention;

FIG. 3B is a partially exploded schematic perspective view of the track of *Figure 3A*, according to some exemplary embodiments of the invention;

FIGs. 4A-4E schematically illustrate views of a track lighting track having an internal mounting clip receiving space, and a narrow electrical access slot, together with
5 a combined mounting-electrical module for use with track, according to some exemplary embodiments of the invention;

FIG. 4F shows the position of the cross-sectional planes of *Figures 4G-4I*, according to some exemplary embodiments of the invention;

FIGs. 4G-4I schematically illustrate cross-sectional planes through an assembled
10 track and mounting module, according to some exemplary embodiments of the invention;

FIG. 5A shows relationship between magnetically susceptible mounting elements of a track, and corresponding magnetically susceptible mounting elements of a luminaire, according to some exemplary embodiments of the invention;

FIG. 5B shows electrical contacts between one or more contact assemblies of a
15 track and a power contact assembly of a luminaire, according to some exemplary embodiments of the invention;

FIG. 5C shows relationship between magnetically susceptible mounting elements of a track, and corresponding magnetically susceptible mounting elements of a
20 luminaire, according to some exemplary embodiments of the invention;

FIG. 5D shows in cutaway details of the interaction of a luminaire contact assembly with a contact assembly, according to some exemplary embodiments of the invention;

FIG. 6 shows electrical contacts of a track and luminaire power contact
25 assembly in perspective, according to some exemplary embodiments of the invention;

FIG. 7 shows a luminaire having a housing comprising a circular profile sized to the dimensions and shape of a circularly arcuate inset, according to some exemplary embodiments of the invention;

FIGs. 8A-8B schematically illustrate luminaires with separate power,
30 illumination, and/or attachment modules, according to some exemplary embodiments of the invention;

FIGs. 8C–8D schematically illustrate a luminaire having a cross-section sized to the cross-sectional dimensions of an arcuate inset, according to some exemplary embodiments of the invention;

FIGs. 8E–8F show an example of luminaire configured to throw light
5 longitudinally from at least one end along a track, according to some exemplary embodiments of the invention;

FIG. 9A shows a schematic view of a luminaire shaped for use with a track, according to some exemplary embodiments of the invention;

FIGs. 9B-9D show combinations of power, illumination and/or attachment
10 functions in different luminaire designs, according to some exemplary embodiments of the invention; and

FIG. 9E shows an exemplary luminaire comprising a cylindrical housing, according to some exemplary embodiments of the invention.

DESCRIPTION OF SPECIFIC EMBODIMENTS OF THE INVENTION

15 The present invention, in some embodiments thereof, relates to the field of artificial illumination systems and more particularly, to systems for track lighting.

Overview

An aspect of some embodiments of the current invention relates to track lighting systems providing electrical power via a recessed slot having a width and/or an aperture
20 width of about 1–8 mm or less. In some embodiments, the slot and/or slot aperture width is, for example, about 5 mm, 4 mm, 3 mm, 2 mm, 1 mm, or another greater, lesser, or intermediate width. In some embodiments, the slot extends along the track with the designated width for at least 90% of the slot length, and/or at least 90% of the length of the track housing.

25 In some embodiments, the track is provided with mounting means that allow recessed installation. For example, the track is shaped to be mounted with a surface flush or almost flush to a ceiling, wall, or other flat surface. Optionally, the track comprises one or more surfaces which can be covered with material (spackling paste and/or paint, for example) that visually blends the track with the surrounding mounting
30 surface.

A potential advantage of recessed mounting is to reduce the obtrusiveness of the lighting system: of the track portion of the system, and/or of a luminaire which the track is suited to accommodate. In particular, recessed mounting hides from view means of mechanical support and electrical power supply which the track supplies. This is a potential advantage, for example, in lighting applications where control of aesthetics is valued at a premium.

However, luminaires still need to access these functions. In a typical recessed track lighting installation, access is through a slot, the opening of which is itself exposed to view—potentially posing a remaining undesired aesthetic distraction. A narrower slot provides a potential advantage for reduced obtrusiveness of the track system, particularly if coupled with recessed mounting. In some range of sizes (for example, from less than around 3–5 mm, depending on distance and other mitigating factors), the casual perception of a sufficiently narrow slot potentially converts to that of a generic construction feature such as a panel join, if it is noticed at all.

Despite the advantages of a narrower track slot, it is typically required of a design that the physical mounting and the electrical contact made by a luminaire will be both reliable and reversible not just at one location (as for a standard wall plug), but at any location along a significant length, and most likely at a plurality of arbitrary locations along that length simultaneously. A sufficiently reduced slot size, where the slot is required to handle all these functions, potentially impairs one or more of them functions beyond acceptable limits. For example, minimum thicknesses, strengths, clearances, flexing distances, and/or other design parameters potentially come into conflict.

In some embodiments of the present invention, electrical connection and physical (weight-supporting) mounting to a track lighting system are decoupled from one another by a physical separation of these functions, while retaining only a single slot as the visual manifestation of the installation. In some embodiments, this comprises providing a magnetic mounting to an outside (exposed surface-facing) portion of the track, simultaneously with electrical connection recessed from view within the slot. A potential advantage of a magnetic mounting arrangement is to reduce the number of conflicting requirements imposed on the structure of the slot. Potentially, this allows the slot to be built to a thinner dimension without impairing function and/or reliability. In

some embodiments, the electrical interface portion of a luminaire (the part which inserts into the slot) is made correspondingly narrower in width and/or shorter along the slot. For example, the inserting electrical interface portion is about 1 mm wide, about 3 mm wide, about 5 mm wide, or another greater, smaller, or intermediate width. Optionally, the interface portion is or card-like, extending for a distance along the slot which is several times the width of the slot (for example, 5-10, 8-12, 10-15 times or another range of multiple having the same, greater, smaller, and/or intermediate bounds). Optionally, the interface portion is about the same length as width, for example, reduced to a square cross-section that can insert in four different orientations to the slot, or to a higher-sided polygonal or circular form allowing a larger number of orientations relative to the slot's longitudinal axis. It is to be understood that electrodes in such embodiments are optionally provided which extend around one or more sides, and/or placed at a plurality of levels (depths within the slot) in order to ensure contact with power-providing conductors at each active orientation of the luminaire. In some embodiments of the invention, electrical contact with a power-carrying conductor is made at a relatively deep depth within the slot compared to its width, for example, five or more times the width of the slot. In some embodiments, the power-carrying conductor is more shallowly located. Optionally, for example, one or more power conductors are provided at a lip of the slot. In such a case, the slot itself is optionally vestigial, for example, formed simply of the gap between two conductors.

In some embodiments, electrical connection and physical (weight supporting) mounting to a track lighting system co-exist within the slot. One of the requirements of an in-track mounting system, for many installations, is that a luminaire should be insertable and removable directly from any chosen point along the track. However, very thin slots (for example in the 1–5 mm range, or less), are difficult to provide with reliable and functional controls for mount locking/unlocking. In some embodiments of the present invention, a locking mechanism is provided which is configured to activate automatically upon proper positioning, and to unlock upon exertion of a sufficient force. The sufficient force is optionally selected to be enough greater than the weight of a luminaire that the mounting is secure, while being low enough that removal does not damage the track installation or luminaire. For example, in some embodiments, the removal force is set to be within about 3–5x the weight of the luminaire.

Particularly with the narrowest slots (3 mm or less, for example), another potential problem arises, in that a locking member, even if thin enough to insert to the slot, should nevertheless be thinner still at some point to provide enough edge to sufficiently engage a locking surface inside the slot—while being constructed solidly enough to exert force, and/or to insert and extract without damaging the locking mechanism. In the case of a friction mount (where resistance to weight is by frictional pressing against a surface), there may not be thinning of the locking member required, but the robustness of the lateral force is potentially yet more important. In some embodiments of the invention, one or more pairs of separate members are provided which alternate orientation along the length of the mounting interface, facing to and engaging upon opposite side of the slot. Potentially, this in effect allows the mount to be built with robustness equivalent to about twice the thickness which is actually available.

An aspect of some embodiments of the current invention comprises magnetic mounting of a luminaire to a track, the magnetic materials of the mounting being separated by one or more thicknesses of material relatively unsusceptible to magnetism.

Magnetic mountings for use with exposed track lighting systems are described, for example, in U.S. Patent No. 5,154,509 and U.S. Patent Publication 2009/0279298. However, these mountings are not adapted for use with a recessed track lighting system. For example, each relies on magnets used in direct contact with the surface of an attracted material (in the case of U.S. Patent Publication 2009/0279298, the contact is also used for heat dissipation), which is not generally available for a recessed mounting system with an appearance blended into the mounting surface.

In some embodiments of the current invention, luminaires are mounted to a track by the use of magnets and/or magnetically attracted materials. For example, a luminaire is provided with one or more permanent magnets (for example, rare earth magnets, or more particularly, neodymium-alloy magnets), while a track is provided with a magnetically attracted material such as steel. Alternatively or additionally, the positioning of magnetic and magnetically attracted elements is reversed.

In some embodiments, the luminaire contains a sufficient quantity and concentration of magnetic and/or magnetically attracted material to provide holding strength through the layers of aluminum, spackling paste, and/or other material which provide the decorative surfaces of the illumination system. In some embodiments, the

holding strength bridges a gap maintained by differences in the shapes of the most closely apposed surfaces of the luminaire and track. The supporting magnetic field is, for example, sufficient to provide a safety factor of 5x or more over the attractive strength required to secure the luminaire against its own weight. In particular, it is a potential advantage for a magnetic mounting system to bear weight even through a thickness of aluminum, since, although aluminum is not magnetically attracted to a sufficient degree for use in mounting, its use provides a potential advantage otherwise by allowing relatively low-cost extruded production of axially extended members having a complex cross section. The weight which can be borne by a magnetic mounting system is, for example, at least 75% of the weight of the luminaire, at least 100%, at least 200%, at least 300%, at least 500%, or another greater, smaller, and/or intermediate weight.

In some embodiments, the (possibly damaging) exertion of magnetic force against an exposed extent of a friable surface such as plaster or spackling compound is reduced by the provision of a narrow region (for example, a peak, or another region of 1 mm width or less) which closely approaches and/or protrudes from the friable surface, to support a region which substantially bears the forces of magnetic attraction.

An aspect of some embodiments of the current invention comprises the paired use of half-locking members, to provide mounting connection of a luminaire to a recessed track lighting system.

In some embodiments, locking members are each "half-locking" in that each engages only one wall of a slot, each member of a pair engaging a wall opposite the other. Optionally, the half-locking members are offset from each other along the length of the track. Potentially, this allows a locking design requiring a single slot's thickness of material to securely engage even a single wall to be effectively applied to two walls.

An aspect of some embodiments of the current invention comprises the use of locking members which automatically lock upon insertion, and automatically unlock without damage upon exertion of sufficient removal force.

In some embodiments, the sufficient removal force is in the range of about 3x–5x the weight of the supported luminaire, for example, 3x, 4x, 5x, or another greater, lesser, or intermediate multiple. In some embodiments, the unlocking comprises providing a sloped locking surface inside the slot, the incline of the slope being selected

to convert downward force into lateral force that—upon a selected force being exerted—guides the locking member into an unlocked position. Optionally, the slope is on the locking member. Optionally or additionally, the slope is on a surface that the locking member engages.

5 In some embodiments, unlocking without damage comprises, for example, ability to reliably complete a duty cycle of 5, 10, 25, 50, 100, or another greater, lesser and/or intermediate number of insertions and removals without losing the ability to stably support a luminaire.

10 An aspect of some embodiments of the current invention comprises an elongated, transversely and concavely arcuate holding surface for a luminaire along a recessed track.

In some embodiments, the track comprises an elongated, inset region within which a portion of the luminaire body is received; the inset region being itself arcuate across its width. Optionally, a portion of the luminaire body is received along at least 15 90% of the length of the luminaire. Additionally or alternatively, the received portion of the luminaire body comprises a housing fittingly received to the surface of the inset region, from which housing an elongate connection rod and/or wire extends to an illuminating portion of the luminaire. Optionally, the housing is received along at least 90% of the housing length. Optionally, the inset region is wider than a slot which is 20 provided for electrical power axis. Optionally, the slot aperture is located along the surface of the inset region.

A potential advantage of a slotted arcuate surface is to reduce the obtrusiveness (protrusion distance) of a mounted luminaire. It should be noted that this is in exchange for a change in the surface characteristics (in particular, an indentation) of the mounting 25 surface, beyond a single slot.

However, even in this respect, an arcuate inset profile (optionally slotted) provides a potential advantage over a slot alone, in that the surface slope change is more gradual. Thus, shading changes along the track length are potentially less obtrusive than those of a slot, even if the width is wider, particularly if care is taken to appropriately 30 illuminate the inset region itself. Optionally, the arcuate inset region of the track is colored to match the surrounding surface; for example, an aluminum surface is powder coated to match a specification of a wall or ceiling coloration. Potentially, the inset

shape helps the track slot to take on the appearance of a decorative feature, for example, by presenting a form which is less obviously utilitarian than a raw slot.

An aspect of some embodiments of the current invention is a magnetic mount, wherein the magnetic material is installed axially alongside and within about 15 mm of the luminous elements of a magnetically mountable luminaire.

In some embodiments of the current invention, luminous elements and magnets for mounting are provided within about 15 mm of each other. In some embodiments, the elements are within about 10–20 mm, about 10–15 mm, about 5–15 mm, about 5–10 mm, about 0–5 mm, or within another range of distances having the same, larger, smaller, and/or intermediate bounds. A potential advantage of a short magnet-luminaire distance is that magnetic mounting and luminosity can be provided along the same length of a luminaire (allowing, for example, an optionally higher amount of magnetic material to be added), while the luminaire itself remains relatively low profile.

In some embodiments, for example, a cross section of a luminaire and/or of a luminaire mounting portion comprises a 15 mm radius half-circle, or a curve of another radius, for example, 10 mm, 20 mm, 25 mm, or another greater, lesser, and/or intermediate radius. In an exemplary arrangement, illuminating elements are optionally provided about centered on the radiating surface of the luminaire (slightly inset from the half-circle diameter, for example), while the magnetic mounting elements are provided spaced about 3–4 mm from the circumferential portion of the half-circle. Assuming reasonable element thicknesses, where magnet and illuminating element are provided within the same cross section, the minimum distance between magnet and illuminating element is thus about 10 mm or less, in some embodiments.

Before explaining at least one embodiment of the invention in detail, it is to be understood that the invention is not necessarily limited in its application to the details of construction and the arrangement of the components and/or methods set forth in the following description and/or illustrated in the drawings. The invention is capable of other embodiments or of being practiced or carried out in various ways.

Track with Flat Mounting Surface, and Mating Luminaire Designs

Reference is now made to *Figure 1A*, which is a schematic perspective view of a track **100** for a recessed track lighting system comprising a narrow power access slot **130** and a magnetically attracted mounting strip **110**, for power delivery and mechanical

support, respectively, of a luminaire, according to some exemplary embodiments of the invention. Reference is also made to *Figure 1B*, which is a partially exploded schematic perspective view of the track **100** of *Figure 1A*, according to some exemplary embodiments of the invention.

5 In some embodiments of the invention, track **100** comprises track housing **101**. Optionally, track housing **101** comprises an extruded aluminum manufacture. In some embodiments, track housing **101** comprises an interior region **130** formed as a slot open through aperture **130A** in a ventral side of the track **100** (the ventral side being considered as the side of the track **100** facing the exposed mounting surface **108**). In
10 some embodiments, the walls of slot **130** comprise surfaces of one or more contact assemblies **120** carrying power rails **121** for bringing power to contacts of a luminaire. For example, the track **100** comprises two contact assemblies **120**, each carrying two power rails **121**. The contact assemblies **120** occupy corresponding receiving spaces **104** within the track housing **101**.

15 A narrow slot **130** is provided in some embodiments of the invention, for example, a slot having a width in the range of 1–8 mm; more particularly, about 5 mm, about 3 mm, about 1 mm; or another larger, smaller, and/or intermediate value. Slots of this narrowness are a potential advantage for allowing the appearance of a space to be
20 designed for flexible positioning of lighting with lowered impact on appearance by the lighting infrastructure itself. Apart from being visually thinner, a narrower slot potentially reduces the deepest extent of shadowing visible at most view angles.

 In some embodiments of the invention, track **100** comprises one or more mounting elements **110**; the mounting elements **110** being formed, for example, as plates which extend along a luminaire mounting surface **108** of the track **100**. In some
25 embodiments of the invention, mounting element **110** comprises a magnetically attracted material such as steel or another iron alloy. Optionally inset **110** is itself magnetized. In some embodiments, track housing **101** itself comprises a magnetically attracted and/or magnetized material. However, it is a potential advantage to provide inserts **110** as pieces separate from track housing **101**, to allow taking advantage of
30 technologies of manufacture using non-magnetic materials (for example aluminum extrusion) in the formation of the profile of the track body.

It is to be understood that mounting elements **110** are optionally provided in different variations of construction consistent with the provision of sufficient magnetically susceptible material, positioned to allow reliable support of a mounted luminaire. Optionally, mounting elements **110** incorporate other functionality. For example, in some embodiments, mounting elements **110** include construction features for securing to the track housing **101**, and/or related to installation of the track **100**.

In some embodiments, track housing **101** includes one or more mounting element slots **102**, **103** shaped to receive at least a portion of the mounting element **110**, for positioning and/or securing of the mounting element **110** to the track housing **101**. For fitting to slots **102**, **103**, for example, mounting element **110** comprises an angle bend along a longitudinal axis of the track **100**, the bend connecting plate regions **112A** and **112B**. During assembly, the plate regions **112A**, **112B** optionally insert into one side of the two slots **102**, **103**, and slide along the track housing **101**. In this example, slots **102**, **103** are positioned such that the resulting assembly positions a portion of plate **112A** on an outermost surface of the track **100**, at and/or close to luminaire mounting surface **108**. This is a potential advantage for providing increased strength and/or reduced magnetic material requirements for mounting. However, in some embodiments, a mounting element is held entirely within a track housing (as illustrated, for example, for mounting element **210** in track body **201**, in relation to *Figures 3A–3B* hereinbelow).

Reference is now made to *Figure 5A*, which shows relationship between magnetically susceptible mounting elements **110** of a track **100**, and corresponding magnetically susceptible mounting elements **510** of a luminaire **500**, according to some exemplary embodiments of the invention. Reference is also made to *Figure 9A*, which shows a schematic view of a luminaire **910** shaped for use with a track **100**, according to some exemplary embodiments of the invention.

In some embodiments, a luminaire **500** comprises one or more mounting elements **510** which are positioned on and/or within the housing **501** of the luminaire **500**. In some embodiments, mounting elements **510** comprise magnets (for example, rare earth magnets) which are attracted to the magnetically susceptible material of mounting elements **110**. Luminaire **910** of *Figure 9A* provides a perspective view of a luminaire having a flat top surface adapted to mate with track **100**.

In some embodiments, mounting is by inserting power contact assembly **520** into slot **130**, then shortening the distance **560** until magnetic attraction between elements **110** and **510** is sufficiently strong to close the gap and/or maintain the position. It should be noted that the relative positions of the luminaire **500** and the track **100** is controlled, in some embodiments, by a protruding member **131**. Magnetic interactions at this smallest distance determine the available holding strength.

In some embodiments of the invention, mounting elements **110** are provided with surface irregularities **113**; for example, perforations **113** and/or another irregularity such as divots, bumps, and/or ridges. In some embodiments, the irregularities are spaced at regular or irregular intervals of about 1–10 mm, or at another greater or lesser interval. A potential advantage of surface irregularities **113** is for increasing the stability of adhesion of a surface treatment (for example, spackling paste) applied during installation to an exposed surface of the mounting element **110**. It should be noted that potential mechanical damage to a surface treatment (for example, due to magnetic attraction forces and/or sliding of the luminaire) is limited, in some embodiments, by keeping the fill-in level to a thickness less than or equal to the distance which protruding member **131** stands proud of the ventral side of the track.

In some embodiments, track **100**—optionally, track housing **101** in particular—comprises one or more additional features adapted to support incorporation with surrounding materials for mounting. Shown in *Figures 1A–1B*, for example, is flange **105**, which is spaced back from the ventral side of the track **100** to allow flush or nearly flush mounting with, for example, a standard thickness of mounting board such as wallboard, ceiling board, or other architectural mounting surface **140** of an architectural space (for example, a hall, room, courtyard or other space defined by a building). Such a standard thickness is, for example, about 6.4 mm, 7.9 mm, 9.5 mm, 12.7 mm, 15.9 mm, 19.0 mm, 25.4 mm, another thickness of within about 5-30 mm, or another greater or lesser thickness. In some embodiments, a portion of the ventral face of the track **106** is provided with surface irregularities **107**, for example, ridges (as shown), or another irregularity such as divots, bumps, or perforations (spaced, for example, at regular or irregular intervals of about 1–10 mm, or another greater, lesser, or intermediate interval). A ridged irregularity with ridges running longitudinally along the track is optionally used, for example, to accommodate an extruded aluminum construction of

the track housing **101**. Potentially, irregularities **107** help to improve binding of a surfacing material **141** such as spackling paste to the track body **101**.

In some embodiments, the form of track housing **201** is provided with one or more installation features such as brackets, holes, slots, or other forms which can be
5 attached to by mounting hardware and/or surfaces.

Reference is made to *Figure 2*, which is a partially exploded schematic view of a contact assembly **120**, according to some exemplary embodiments of the invention.

In some embodiments, each contact assembly **120** comprises one, two, or more power rails **121**. Arrangements of power connections to power rails **121** is described, for
10 example, in relation to *Figure 5B*, hereinbelow. In some embodiments, a power rail **121** is fitted to a housing **122** of a contact assembly **120** within a rail receiving slot **123**. In some embodiments, housing **122** comprises an insulating material such as a plastic resin, for example, a polycarbonate resin. Optionally, the insulating rail element is manufactured by an extrusion method. In some embodiments, the resin is chosen with
15 sufficient flexibility to allow a snap fit to be obtained after housing **122** inserts into the receiving space **104** of the track housing **101**. For example, the housing **122** is inserted to the receiving space **104** in a loose position within the housing cross-section, and afterward manipulated to a snap-fitted position.

In some embodiments, the resin (such as polycarbonate) is chosen for a
20 relatively high electrical resistance, high resistance to heat deformation and/or low flammability. In some embodiments, a contact assembly **120** comprises surfaces sized and shaped for interacting with the surfaces of track housing **101** for positioning and/or locking of the contact assembly **120** within the receiving space **104**, for example, surfaces **125**, **126**, and/or **127**. With respect to surface **125**, it is noted that it is a
25 potential advantage for manufacture to provide surfaces of the contact assembly **120** which are positioned to interact flexibly (through bending of the arm comprising surface **127**, for example) and over a relatively small cross-section (defined, for example, by the overlap between surface **125** and the portion of housing **101** which it contacts), so as to reduce the chances of interference between housing **101** and contact assembly **120** when
30 the contact assembly **120** is inserted into its receiving space **104**. For example, interference is reduced sufficiently so that contact assembly **120** can be optionally push-

inserted to a distance of about 5 meters (or a greater or lesser length) during the manufacture of an assembled length of track.

Optionally, rail receiving slot **123** further comprises a flexing cut **124**. Flexing cut **124** provides a potential advantage for insertion of rail **121** to slot **123** by opening to allow pressure from rail **121** to force open slot **123** upon being pressed thereto during assembly.

Reference is now made to *Figure 5B*, which shows electrical contacts between one or more contact assemblies **120** of a track **100** and a power contact assembly **520** of a luminaire, according to some exemplary embodiments of the invention. Reference is also made to *Figure 6*, which shows electrical contacts of a track **100** and luminaire power contact assembly **520** in perspective, according to some exemplary embodiments of the invention.

In some embodiments, one or more power rails **121** (for example, rails **121A–121D**) are provided by a contact assembly **520** within a slot **130**. These allow a luminaire to receive power from the track **100** through its own power contact assembly **520**. The luminaire power contact assembly **520** comprises mating contacts **521**, which are positioned on assembly **520** so that they reach to and form reliable electrical connections **570** with contact assembly **120**. Proper spacing, in some embodiments, comprises abutting a portion of a luminaire such as the power contact assembly **520** itself against an appropriately sized spacing element such as protruding member **131**.

In some embodiments, the electrical connection between track and luminaire is a low voltage connection (12 volts, for example, or another voltage less than about 50 volts). Potentially, this reduces the chance of arcing between bare portions of rails **121A–121D** held in relatively close proximity. In some embodiments, a higher voltage (for example, line voltage of 120 volts, 220 volts, or another voltage) is used. Supply is, for example, AC or DC. In some embodiments, the power rails **121A–121D** are arranged with two supply lines and two ground and/or neutral lines. Optionally, both pairs are powered from the same voltage and/or current supply (in constant current or constant voltage mode, according to selected electrical parameters of operation). This is a potential advantage to allow the same luminaire to be inserted in any orientation with respect to the track, and still receive power from the same circuit. Optionally, a plurality of separately controlled power supplies are connected to different pairs of power rails

121A–121D. This has the potential advantage of allowing two separate track lighting control groups along one rail (for example, selected according to an orientation of a luminaire or a portion thereof with respect to the track). Additionally or alternatively, different luminaires are set to operate within different control groups according settings controlled by another means, for example, solid state switching and/or wireless (radio or IR, for example) control. In some embodiments, a portion of the electrical circuit used to power a luminaire includes the material of the track housing **101** itself, and/or another part of the track **100**, such as a mounting element **110**.

In some embodiments, mating contacts **521** comprise a tensioning means to help ensure constant contact with the power rails **121**. In some embodiments, the tensioning means comprises forming a portion of each mating contact **521** as a leaf spring. Additionally or alternatively, a portion of the material to which a mating contact **521** is mounted is configured to urge mating contacts and power rails **121** into contact.

In some embodiments, contact assembly **520** comprises a casing which holds mating contacts **521** within itself. Optionally, casing **520** compresses the springs to a sufficient degree that their outward force to mate with power rails **121** is well developed (for example, about 0.5 N, **1 N**, **2 N**, or another higher, lower or intermediate force), and maintained reliably over the service lifetime of the luminaire.

Track with Arcuate Mounting Surface, and Mating Luminaire Designs

Reference is now made to *Figure 3A*, which is a schematic perspective view of a track **200** for a recessed track lighting system, comprising a narrow power access slot **230** and magnetically attracted mounting plates **210** shaped to accommodate an arcuately profiled inset **250**, according to some exemplary embodiments of the invention. Reference is also made to *Figure 3B*, which is a partially exploded schematic perspective view of the track of *Figure 3A*, according to some exemplary embodiments of the invention.

In some embodiments of the invention, track **200** comprises track housing **201**. Optionally, track housing **201** comprises an extruded aluminum manufacture.

In some embodiments of the invention, track housing **201** comprises an arcuately profiled inset region **250** on a ventral (exposed) side. In some embodiments, the arcuately profiled region comprises an inset portion of a circular arc. Optionally, the arc is non-circular, for example, a portion of an ellipse or other curve. The radius of the

inset portion is, for example, in the range of from about 1 cm to about 3 cm; and/or, more particularly, about 1 cm, 1.5 cm, 2 cm, 2.5 cm, or another greater, lesser or intermediate radius. In some embodiments of the invention, the fraction of the circumference subtended by the surface **251** of the inset is about 50%. Optionally, the circumferential fraction subtended is another value, for example, a value ranging from about 10% to about 70% of the circumference defined by an arc radius of the inset region **250**, or a circumferential fraction selected from another range having the same, greater, lesser, and/or intermediate values.

In some embodiments of the invention, track **200** comprises one or more mounting elements **210**, optionally comprising a magnetically attracted material as described in relation to mounting elements **110**.

In some embodiments, track housing **101** includes one or more mounting element slots **202** shaped to receive at least a portion of a mounting element **210**, for positioning and/or securing of the mounting element **210** to the track housing **201**. For example, mounting element **210** comprises a curved profile shaped to conform to a luminaire mounting surface **251** along inset arcuate region **250**. In this example, the mounting elements **210** are hidden behind the mounting surface **251**. This is a potential advantage for allowing the appearance of an exposed portion **251** of the track housing **101** to be controlled separately from the material constraints applicable to the mounting element **110**.

Reference is now made to *Figure 5C*, which shows relationship between magnetically susceptible mounting elements **210** of a track **200**, and corresponding magnetically susceptible mounting elements **602** of a luminaire **600**, according to some exemplary embodiments of the invention. Reference is also made to *Figure 7*, which shows a luminaire **600** having a housing **601** comprising a circular profile sized to the dimensions and shape of a circularly arcuate inset **250**, according to some exemplary embodiments of the invention.

In some embodiments, a luminaire **600** comprises a housing **601** having an arcuate profile sized to the dimensions of the inset region **250** (or, optionally, any portion of the inset profile dimensions).

As described also in relation to track **100**: mounting of a luminaire **600** to track **200**, in some embodiments, comprises bringing together track **200** and a housing **601**

comprising magnetic mounting means **602** which interact with mounting elements **210** of track **200** (arrow 660 schematically indicates the force of magnetic attraction). Optionally, the magnetic mounting means **602** have a shape complementary to the shape of mounting elements **610**. This allows magnetic mating to occur throughout a substantial portion of surface region **251**; optionally a surface region portion which is larger than that which would be available from a flat mounting surface. Potentially, this increases stability of mounting.

Optionally, the construction of luminaire **600** allows rotation **701** (*Figure 7*) around an axis of the inset region **250**, while maintaining a large area of mounting contact with surface **251**. Potentially, this adds flexibility in directing an axis of illumination **702** of the luminaire **600**, while maintaining good mounting contact.

Reference is now made to *Figure 9E*, which shows an exemplary luminaire **950** comprising a cylindrical housing, according to some exemplary embodiments of the invention. In some embodiments, rotation is provided together with electrical connection by putting illuminating elements **610** on a rotatable portion **832** of the housing **601**, while another portion **831** of the housing **601** comprises the luminaire power contact assembly **620**. Optionally, the two portions are linked by an internal power connection, for example, a connecting passing through one or more power interconnect lumens **616**. Other example of luminaires comprising two such portions include luminaires **830** (portions **832** and **831**) and **840** (portions **842** and **841**) of *Figures 8C–8F*.

Reference is now made to *Figures 8C–8D*, which schematically illustrate a luminaire **830** having a cross-section sized to the cross-sectional dimensions of an arcuate inset **250**, according to some exemplary embodiments of the invention.

In some embodiments, profiles of luminaire **830** and arcuate inset **250** are matched such that all or a portion of the luminaire **830** can be inserted to the inset **250**. Potentially, this results in flush-mounted illuminating surface **833**. For example, in some embodiments, a semi-circular luminaire **830** (such as a half cylinder) comprises an illuminating surface **833** across an exposed diameter. A semi-circular inset region optionally allows this surface to be placed parallel and flush to the installation surface **108** of the track **200**.

It is to be understood that a luminaire profile that fits into arcuate inset region **250** is not necessarily shaped to conform to surface **251**. For example, the luminaire optionally conforms at least in part to a smaller radius arc, and/or to a larger radius arc (having a circumference subtending a smaller angle). Although this potentially reduces a degree of magnetic attraction between luminaire and track (due to there being magnetically susceptible portions which cannot completely approach each other), it indicates how more variety of form may be achieved. It should also be noted that although flat track **100** has been described in relation to the mounting thereto of a correspondingly flat-surfaced luminaire (such as luminaire **910**), the track is also used, in some embodiments, to receive luminaires of other forms (such as round-bodied luminaire **950**). Potentially, this provides a different aesthetic to the lighting system, the shape and the narrow slot combining to give luminaires an “unsupported” look, even though the mounting strength is adequate to the requirements of the installation.

The surface **251** of the arcuate inset region **250** is optionally treated (for example, painted and/or provided with a powder coating) to provide a surface which is matched to its mounted surroundings. Optionally, the surface is counter-shaded so that the surface treatment blends with the surroundings best under appropriately designed lighting conditions. For example, a powder coating for a region which is to be positioned where it receives less illumination is applied so that it is correspondingly lighter in color, helping to mask and/or change the appearance of the installation.

It should be noted that there are potential aesthetic differences between an arcuate inset region with a thin slot and a single thick “square” slot of a standard track lighting system. The arcuate inset region provides a smooth surface **251** which is potentially interrupted only by the slot, as opposed to an interior which includes potentially visible hardware for mounting and/or electrical power access. The arcuate inset region has a relatively narrow region with a sharp slope difference from the mounting surface, which potentially reduces the width and/or intensity of shadowing changes due to differences of illumination angle. Potentially, the arcuate inset region is provided with a more open form than would be appropriate for a single square slot (where there may be an incentive to hide some internal details), the broader profile helping to reduce shading depth.

Furthermore, the arcuate inset shape is optionally installed as a deliberately visible design element. Optionally, the lighting is chosen to illuminate the track, for example as a decorative accent.

Reference is now made to *Figures 8E–8F*, which show an example of luminaire **840** configured to throw light longitudinally from at least one end **843** along a track **250**, according to some exemplary embodiments of the invention. In an example of use, a track comprising inset region **250** is installed to run vertically down a wall, with an installed luminaire **840** acting as a sconce and/or downlight which directs at least a portion of its illumination to emphasize the track it sits in. Potentially, this creates the effect of a relatively sharply defined illuminated wall section. Additionally or alternatively, along-the-track lighting is provided for countershading.

It should be understood, moreover, that a narrow slot is coupled, in some embodiments of the invention, with any open-sided, inset cross-section shape. Thus, the arcuate inset with narrow slot is an example more generally of a “double slot” design concept, where the most visible slot is of any polygonal cross section open on one side, for example, rectangular, triangular, half-hexagon, lobed (starred, for example) or other. In relation to a lobed cross section, for example, it can be noted that the slot is optionally located to be at one of the lobes, such that it is in effect masked by the surrounding lobes. As a further example, some embodiments of the invention comprise a track shaped for vertical mounting at a convex corner where two walls meet, the inset region comprising a “V” (or other shape), and the corresponding luminaire being optionally flush on two sides with a surface of each wall.

In some embodiments, track housing **201** comprises an interior region **230** formed as a slot open through aperture **230A** in a ventral side of the track **200**. Optionally, aperture **230A** is in the surface **251** of the arcuately profiled inset region **250**. In some embodiments, the walls of slot **230** comprise surfaces of one or more contact assemblies **120** carrying power rails **121** for bringing power to contacts of a luminaire. For example, the track **200** comprises two contact assemblies **120**, each carrying two power rails **121**. The contact assemblies **120** occupy corresponding receiving spaces **204** within the track housing **201**.

Reference is now made to *Figure 5D*, which shows in cutaway details of the interaction of a luminaire contact assembly **620** with a contact assembly **120**, according to some exemplary embodiments of the invention.

In some embodiments, a portion of contact assembly **620** is sized and shaped to fittingly insert into slot **230**, bringing electrodes **621**, **622** into contact with power rails **121**. In some embodiments, contact assembly **620** is surrounded by a luminaire housing **601** (not shown in *Figure 5D*). It should be noted that as the track surface **251** itself bears the force of contact between luminaire and track, a protective standoff region at the aperture to the track is optionally omitted.

As described in relation to track **100**, track **200** comprises, in some embodiments, mounting features such as a flange **105** and/or surface irregularities **106**.

Alternate Thin Slot Design

Reference is now made to *Figures 4A–4E*, which schematically illustrate views of a track lighting track **400** having an internal mounting clip receiving space **410**, and a narrow electrical access slot **430**, together with a combined mounting-electrical module **450** for use with track **400**. Reference is also made to *Figures 4G–4I*, which schematically illustrate cross-sectional planes through an assembled track **400** and mounting module **450**. Reference is further made to *Figure 4F*, which shows the position of the cross-sectional planes of *Figures 4G–4I*.

Figures 4A–4I emphasize the connecting and mounting functions of the track; however it is to be understood that module **450** is optionally provided together with any of the luminaire (illumination portion) designs described herein.

Track **400** comprises a track housing **401** which comprises an access slot **430** of, for example, 3 mm or less (for example about 2 mm, 1.5 mm, 1 mm, or another greater, smaller, or intermediate width). The narrow slot dimensions makes it potentially more difficult to provide an encased electrode contact assembly such as that of *Figures 5B* and *5D* that will function reliably. In some embodiments, contact module **450** comprises a card body **451** of stiffly elastic insulating material (shown inserted in all of these figures except for *Figure 4A*). In some embodiments, the card body **451** comprises, for example, a fiber impregnated thermoset resin such as is used in the manufacture of laminated printed circuit boards. For example, the body material is chosen from among materials such as FR-1, FR-2, FR-3, FR-4, FR-5, FR-6, G-10, CEM-1, CEM-2, CEM-3,

CEM-4, CEM-5, and/or another material, such as polycarbonate resin. Optionally, the material is chosen to have sufficient durability to withstand long periods of under flexed compression and/or wide temperature range without loss of restorative force.

In some embodiments, the card body **451** comprises one or more tongue-like protrusions **460**, **471**, **472** which protrude generally along but at least partially beyond the volume defined by the main flat surfaces of the main card body **451** (except when the tongues are compressed). Optionally, manufacture of the tongues comprises cutting away thicknesses of an original stock to leave a thinner card body (for example, a 3-mm thick body), with protrusions left beyond this thickness where required. Additionally or alternatively, the card material is cast, layered, and/or cured with a bend already imparted to the material.

In some embodiments, clip members **460** are provided for mechanical mounting of a luminaire. The cross section **481** of *Figure 4G* is through an exemplary clip member **460**, and elements of such a clip member are also labeled in *Figures 4A* and *4E*.

Optionally, clip members are provided in one or more pairs, each element of the pair being shaped to engage with an opposite wall of the track **400**: for example, shaped to engage a ledge **411** inside clip receiving space **410**. Each clip member **460** is formed with a relatively thin and elongated neck **461** leading to a retaining head **462**. Each retaining head **462** is narrow enough to pass through slot **430**, while the overall clip member **460** is sufficiently compressible to follow behind. Upon entering the relatively open area of clip receiving space **410**, the retaining head **462** springs outward and braces, for example, against ledge **411**. In some embodiments, retaining head **462** is shaped with a relatively narrow leading end **463** so that the head becomes aligned with the slot opening upon being pressed thereto during insertion.

In some embodiments, retaining head **462** is shaped with an incline on the trailing edge **464**, the incline **464** being shaped so that with sufficient pulling force during removal, the interaction of the incline with one or more edges (such as ledge **411**) within the clip receiving space **410** forces the retaining head **462** back into alignment with slot **430**. So-aligned, the retaining head **462** can be removed. Additionally or alternatively, retaining head **462** is held in place by friction with a surface of the clip receiving space **410**.

In some embodiments, the retrieval force required to remove the luminaire from the slot **430** is about 3x greater than the weight of the luminaire which module **450** supports (or another factor such as about 2x, 3.5x, 5x, or another greater or lesser factor). In some embodiments, the retrieval force is in the range of about, for example, 5–10 N, 5–15 N, 10–15 N, 10–20 N, 15–30 N, or another range having the same, greater, smaller, and/or intermediate bounds.

In some embodiments, contact module **450** is provided with one or more surfaces **470** in card **451** (for example, a ground channel and a voltage/current supply channel), optionally surfaces of channels. The surfaces are at least partially filled, coated, plated, arc sprayed, flame sprayed, vacuum metalized, and/or otherwise provided with a conductive material (metal). Optionally, the process used is a process known in the manufacture of printed circuit boards, and/or the metallization of plastic.

In some embodiments, plating reaches along contact protrusions **471**, **472**, which are optionally formed as smaller tongues than those of clip member **460**. The cross section **482** of *Figure 4H* is through an exemplary contact protrusion **472**, and cross section **483** of *Figure 4I* is through an exemplary contact protrusion **471**.

In some embodiments, metal plating **473**, **475** of each contact **472**, **471** extends to a region **474**, **476** which is pressed against a power rail **121** when the contact module **450** is fully inserted into the track slot **430**. Arrangements of voltages and other options for power connection are optionally provided as described, for example, in relation to the arrangements of *Figures 5B* and *5D*.

It is to be understood that although the clip mount (comprising space **410** and clips **460**) and the tongue contact mechanism (comprising contacts **471**, **472**, electrode channel **470**, and electrodes housed therein) have been presented in the context of a single embodiment, they are provided separately in some embodiments. For example, the tongue contacts **472** are provided with a magnetic mount such as one described hereinabove, and/or the clip mount **410**, **460** is provided together with an electrical contact module similar to module **520** and/or **620**.

Luminaire Designs having Separable Modules

Reference is now made to *Figures 8A–8B*, which schematically illustrate luminaires with separate power, illumination, and/or mounting modules, according to some exemplary embodiments of the invention. Reference is also made to *Figures 9B–*

9D, which show combinations of power, illumination and/or attachment functions in different luminaire designs, according to some exemplary embodiments of the invention.

In some embodiments, functions of a luminaire and/or its interaction with the track are divided into two, three, or more modules. For example, *Figures 8A–8B* and *9B* show embodiments of a longitudinally extended luminaire **810**, **820**, **920**, where the illuminating section **813**, **814**, **922** depends at either end from two corresponding modules **812**, **811**, **931** which mount to and/or provide an electrical interface with a track such as track **100** or track **200**. Module **812**, for example, comprises a half-round (semicircular) body, optionally provided with magnetic means such as described herein above for luminaire **600**. From module **812** depends a cord **816** which is provided for mechanical support of its end. Modules **811** and **931** comprise a full-round (circular) and half-round (semicircular) body, respectively, provided with both mounting and electrical interface means, for example as described in relation to the embodiments of other luminaires herein, including those of *Figures 1A–1B*, *3A–3B*, and/or *4A–4I*. Cord **815** optionally comprises both wires for electrical power transmission to the illuminating sections **813**, **814**, **922**, and mechanical support of one end. Luminaires **813** and **814** are shown differing from one another in length. Luminaire **920** shows a different overall shape of the illuminating portion **922**, and is an example of a luminaire comprising two separate electrical as well as physical connections to the track.

Luminaires **930** and **940** illustrate examples of single-attachment luminaires, where attachment and electrical interfacing are both managed by one module **931**, while the illuminating sections **932**, **942** which hang from them are shaped according to any design compatible with the load bearing capacity of the module (or modules, since more than one load bearing module is optionally provided to obtain appropriate bearing capacity). In some embodiments, the load bearing capacity of a module (with an appropriate safety factor of, for example, about 5x) is, for example, about 0.5 kg, 1 kg, 1.5 kg, 2 kg, or another larger, smaller, or intermediate load bearing capacity.

It is to be understood that the shapes shown are exemplary only, and not limited to the particulars shown. For example, any of the modules is optionally replaced by a semicircular, circular, rectangular block, or other shaped housing, for example, any shape described herein.

It is expected that during the life of a patent maturing from this application many relevant illumination sources will be developed and the scope of the term luminous element is intended to include all such new technologies *a priori*.

As used herein, the term “about” refers to within $\pm 10\%$.

5 The terms “comprises”, “comprising”, “includes”, “including”, “having” and their conjugates mean: “including but not limited to”.

The term “consisting of” means: “including and limited to”.

The term “consisting essentially of” means that the composition, method or structure may include additional ingredients, steps and/or parts, but only if the additional ingredients, steps and/or parts do not materially alter the basic and novel
10 characteristics of the claimed composition, method or structure.

As used herein, the singular form “a”, “an” and “the” include plural references unless the context clearly dictates otherwise. For example, the term “a compound” or “at least one compound” may include a plurality of compounds, including mixtures
15 thereof.

The words “example” and “exemplary” are used herein to mean “serving as an example, instance or illustration”. Any embodiment described as an “example or “exemplary” is not necessarily to be construed as preferred or advantageous over other embodiments and/or to exclude the incorporation of features from other embodiments.

20 The word “optionally” is used herein to mean “is provided in some embodiments and not provided in other embodiments”. Any particular embodiment of the invention may include a plurality of “optional” features except insofar as such features conflict.

As used herein the term “method” refers to manners, means, techniques and procedures for accomplishing a given task including, but not limited to, those manners, means, techniques and procedures either known to, or readily developed from known
25 manners, means, techniques and procedures by practitioners of the chemical, pharmacological, biological, biochemical and medical arts.

Throughout this application, various embodiments of this invention may be presented in a range format. It should be understood that the description in range format
30 is merely for convenience and brevity and should not be construed as an inflexible limitation on the scope of the invention. Accordingly, the description of a range should be considered to have specifically disclosed all the possible subranges as well as

individual numerical values within that range. For example, description of a range such as from 1 to 6 should be considered to have specifically disclosed subranges such as from 1 to 3, from 1 to 4, from 1 to 5, from 2 to 4, from 2 to 6, from 3 to 6, *etc.*, as well as individual numbers within that range, for example, 1, 2, 3, 4, 5, and 6. This applies
5 regardless of the breadth of the range.

Whenever a numerical range is indicated herein, it is meant to include any cited numeral (fractional or integral) within the indicated range. The phrases “ranging/ranges between” a first indicate number and a second indicate number and “ranging/ranges from” a first indicate number “to” a second indicate number are used herein
10 interchangeably and are meant to include the first and second indicated numbers and all the fractional and integral numerals therebetween.

Although the invention has been described in conjunction with specific embodiments thereof, it is evident that many alternatives, modifications and variations will be apparent to those skilled in the art. Accordingly, it is intended to embrace all
15 such alternatives, modifications and variations that fall within the spirit and broad scope of the appended claims.

All publications, patents and patent applications mentioned in this specification are herein incorporated in their entirety by reference into the specification, to the same extent as if each individual publication, patent or patent application was specifically and
20 individually indicated to be incorporated herein by reference. In addition, citation or identification of any reference in this application shall not be construed as an admission that such reference is available as prior art to the present invention. To the extent that section headings are used, they should not be construed as necessarily limiting.

It is appreciated that certain features of the invention, which are, for clarity,
25 described in the context of separate embodiments, may also be provided in combination in a single embodiment. Conversely, various features of the invention, which are, for brevity, described in the context of a single embodiment, may also be provided separately or in any suitable subcombination or as suitable in any other described embodiment of the invention. Certain features described in the context of various
30 embodiments are not to be considered essential features of those embodiments, unless the embodiment is inoperative without those elements.

WHAT IS CLAIMED IS:

1. A track lighting track comprising a luminaire mounting surface having a concavity extending along an elongate track housing; wherein the concavity has an inset arcuate profile transverse to the track housing length, and wherein the inset arcuate profile is interrupted by an opening of a slot, also extending along the length of the track housing, which is further inset from the inset arcuate profile.
2. The track of claim 1, wherein the slot is 8 mm or less in width.
3. The track of any one of claims 1-2, wherein the inset arcuate profile comprises an arc of a circle.
4. The track of any one of claims 1-3, comprising a curved wall extending along the track and defining a surface of the inset arcuate profile; wherein a magnetically attracted material lines the curved wall.
5. The track of claim 4, wherein the magnetically attracted material lines the curved wall on a side of the curved wall opposite the surface of the inset arcuate profile.
6. The track of any one of claims 1-5, wherein the track is configured for recessed mounting relative to a mounting surface of an architectural space.
7. The track of any one of claims 1-6, comprising lateral mounting flanges recessed by a distance from the mounting surface of the track about equal to the thickness of a standard mounting board.
8. The track of claim 7, wherein the distance is sufficiently larger than the thickness of standard mounting board to receive a coating of material blending the appearance of the mounting surface of the track with an exposed surface of a mounting board when mounted thereat.

9. The track of any one of claims 1-8, wherein the slot includes at least one electrical conductor positioned to receive a contact from a power contact assembly of a luminaire and deliver electrical power therethrough.

10. The track of claim 9, wherein the slot includes a region configured to receive and support weight of a luminaire, wherein the weight is transferred to the region through the power contact assembly.

11. The track of any one of claims 1-10, including at least one luminaire having a fixation portion with a convex arcuate profile that fittingly inserts to the concavity.

12. The track of claim 11, wherein the fixation portion includes a power contact assembly configured to insert into the slot to receive electrical power therefrom.

13. The track of one of claims 4-5, including at least one luminaire having a fixation portion which inserts to the concavity; the fixation portion including a material magnetically attracted to the magnetically attracted material lining the curved wall; and the magnetic attraction being sufficient to support at least 75% of the weight of the luminaire.

14. The track of claim 13, wherein the magnetic attraction is between materials separated by at least 2 mm.

15. The track of claim 13, wherein the magnetic attraction is between materials separated by at least a wall or ceiling surfacing material.

16. The track of claim 13, wherein the magnetic attraction is between materials separated by at least a 2 mm thickness of aluminum.

17. The track of any one of claims 11-16, wherein the fixation portion of the luminaire is sized to fit inside the concavity; wherein a flat surface of the fixation portion is substantially flush to the mounting surface adjoining the concavity.

18. The track of any one of claims 11-17, wherein a housing of an illuminating module of the luminaire is sized to fittingly insert to the concavity when the fixation portion of the luminaire is inserted to the concavity; the orientation of the illuminating module relative to a longitudinal axis of the track being configurable from a plurality of orientations.

19. A track lighting system comprising:

an elongate track housing; and

a luminaire having a fixation portion configured for magnetic mounting to the track housing;

wherein:

the fixation portion includes a material magnetically attracted to a magnetically attracted material of the track housing,

closest surfaces of the magnetically attracted materials of the track housing and the luminaire are separated by at least 2 mm when the luminaire is mounted to the track housing, and

the magnetic attraction between the separated magnetically attracted materials is sufficient to support at least 75% of the weight of the luminaire.

20. The track lighting system of claim 19, wherein the magnetic attraction is between materials separated by at least a wall or ceiling surfacing material.

21. The track of claim 19, wherein the magnetic attraction is between materials separated by at least a 2 mm thickness of aluminum.

22. A luminaire for use with a track lighting system comprising:
a housing having a convex track mounting surface comprising an arcuate cross-section;
the luminaire also comprising a power contact assembly protruding from said convex mounting surface.
23. The luminaire of claim 22, wherein the power contact assembly is 8 mm wide or less.
24. The luminaire of claim 22, wherein the power contact assembly is 5 mm wide or less.
25. The luminaire of claim 22, wherein the power contact assembly is 3 mm wide or less.
26. A luminaire for use with a track lighting track, including a power contact assembly comprising a housing and at least one electrode having a tensioning means, the tensioning means being compressed by the housing, and a portion of the electrode being urged outward from the housing by the tensioning means; wherein the power contact assembly is sized to fit within a slot aperture extending along a track.
27. The luminaire of claim 26, wherein the slot aperture is 5 mm wide or less.
28. A track lighting track comprising:
an elongate track housing;
a slot in and extending along the housing, the slot including at least one electrical conductor positioned to receive a contact from a power contact assembly of a luminaire and deliver electrical power therethrough;
wherein an aperture of the slot through which the power contact assembly is received is 8 mm wide or less along at least 90% of the track housing.

29. The track of claim 28, wherein the aperture is 5 mm wide or less.
30. The track of claim 28, wherein the aperture is 3 mm wide or less.
31. The track of claim 28, wherein the aperture is 1 mm wide or less.
32. The track of any one of claims 28-31, wherein the housing is mounted along an exposed surface of an architectural space, such that the only portion of the housing visible from within the architectural space is the slot.
33. The track of claim 32, comprising a means for supporting the weight of a luminaire, wherein the support means is concealed behind the exposed surface.
34. The track of claim 33, wherein the support means provides support by magnetic attraction to a luminaire.
35. The track of any one of claims 28-32, wherein a means for supporting the weight of a luminaire is located within the slot at a position where it contacts a portion of the power contact assembly.
36. A luminaire for a track lighting system comprising:
a plurality of locking members offset from each other along the length of a mounting assembly, wherein the locking members are sized, shaped and sufficiently flexible for fittingly passing into a slot of a track 5 mm wide or less;
each locking member comprising a surface which lockingly engages one wall of the slot upon complete insertion into the slot; and
wherein at least two of said plurality of locking members engage opposite walls upon said insertion to resist extraction from the slot by a force of the weight of the luminaire.

37. The luminaire of claim 36, wherein the region of locking engagement comprises a surface sloped toward the opening of the slot as the sloped surface approaches the slot.

38. The track lighting system of claim 37, wherein the slope of the sloped surface is angled to translate force operating to pull the luminaire free of the slot into a lateral motion of the locking engaging surface, and wherein a force with which the locking engaging surface resists the lateral motion is overcome to free the engaging surface of engagement with the wall of the slot when the pulling force is about three times larger than the force of the weight of the luminaire on the locking member.

39. The luminaire of claim 36, wherein the region of locking engagement comprises a surface which retains the locking member by friction.

40. A method of mounting and unmounting a luminaire to a track lighting system comprising:

pushing a luminaire straight into a slot of a track, thereby locking the luminaire in place;

pulling a luminaire in a direction straight outward from the slot, thereby releasing the luminaire from the locking; and

extracting the unlocked luminaire the rest of the way out of the slot.

41. The method of claim 40, wherein the pulling is with a force of between three to five times the force of the weight of the luminaire.

42. A track lighting system comprising:

an elongated track; and

a luminaire having a luminous element located at a longitudinal position along the track when the luminaire is coupled to the track;

wherein the luminaire comprises at least one magnet magnetically attracted to a material of the track; and

wherein the magnet is located at the longitudinal position, and within 10 mm of the luminous element.

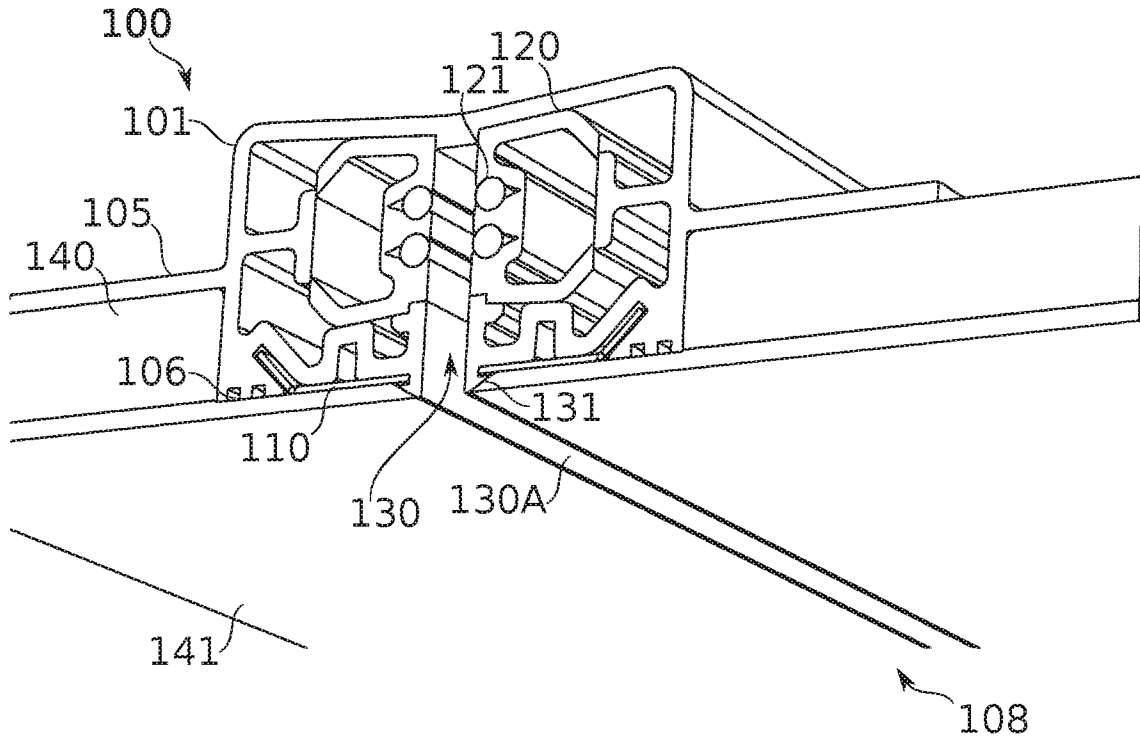

FIG. 1A

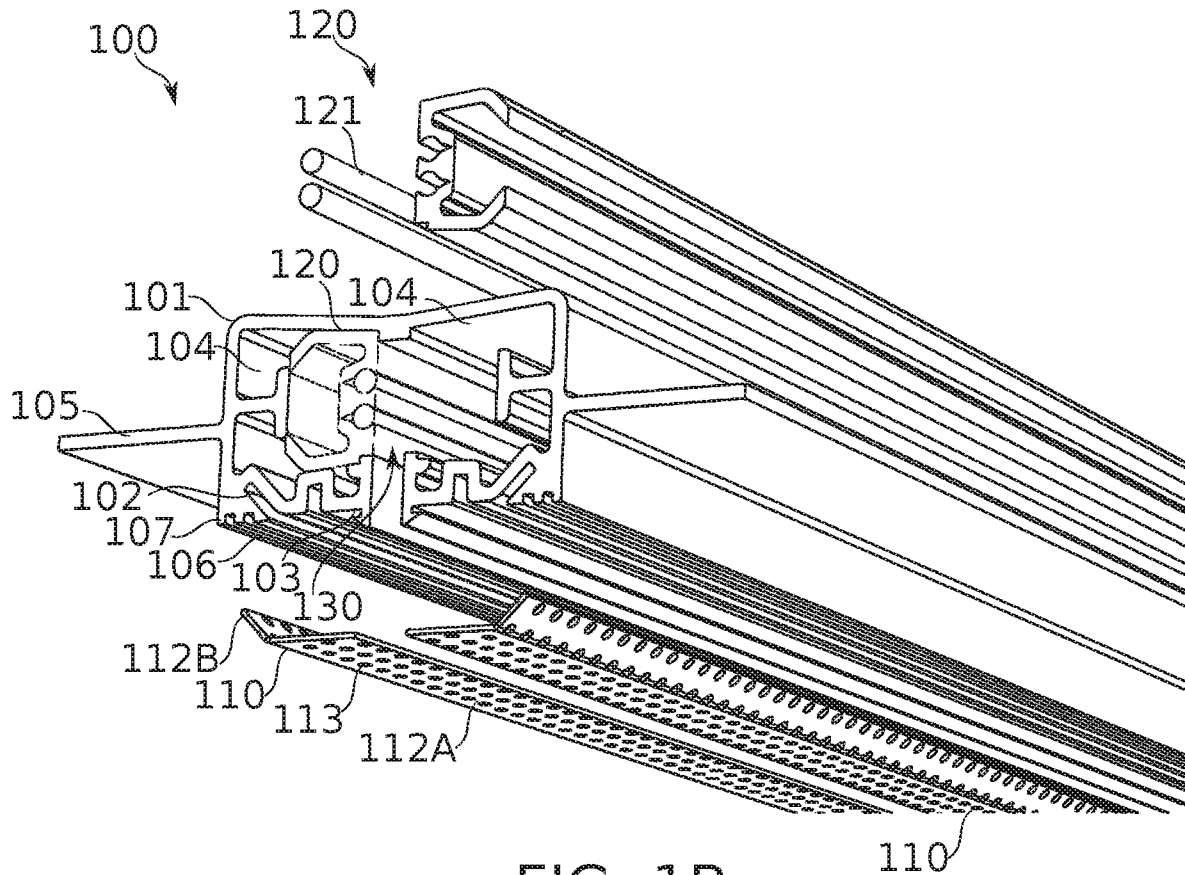

FIG. 1B

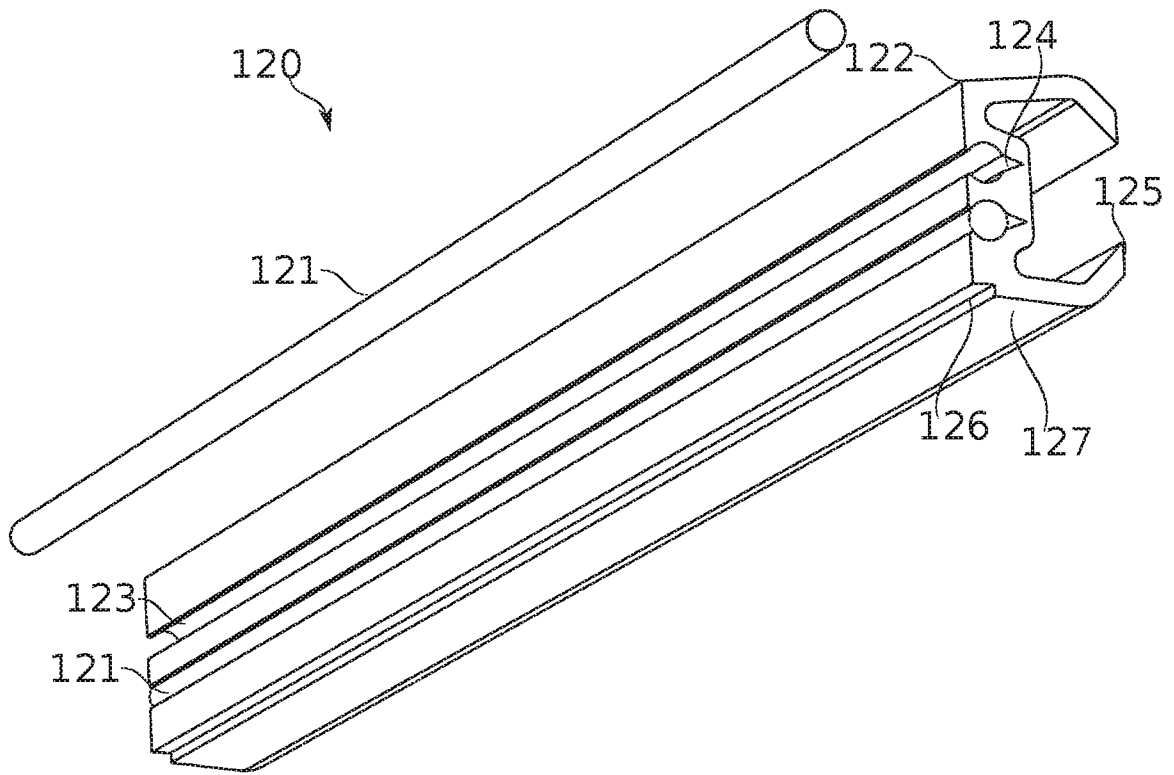

FIG. 2

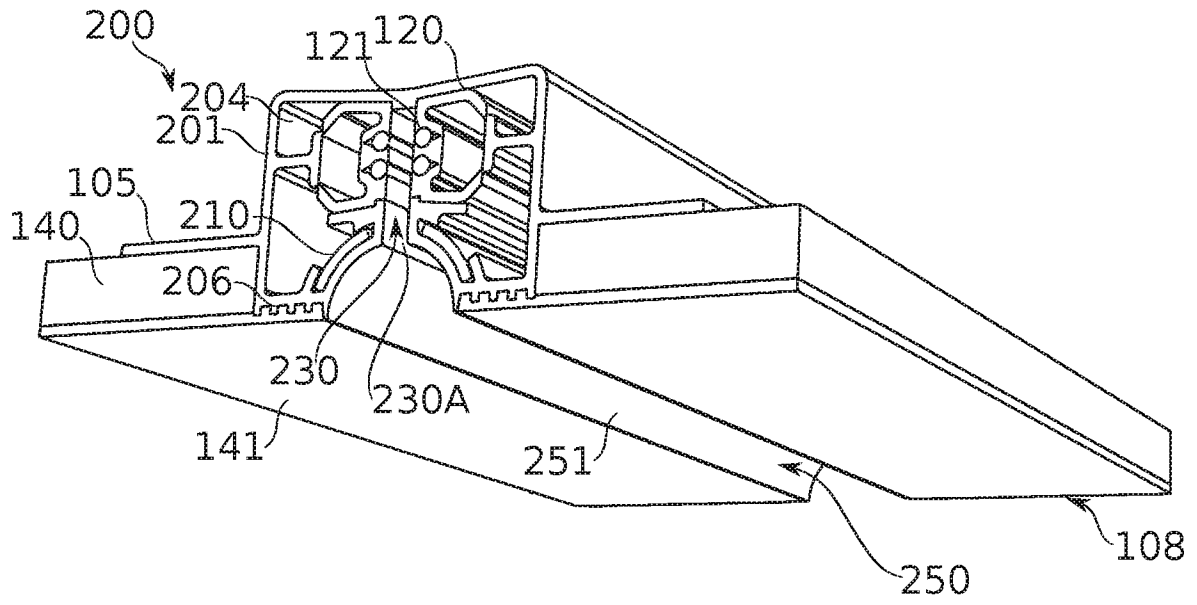

FIG. 3A

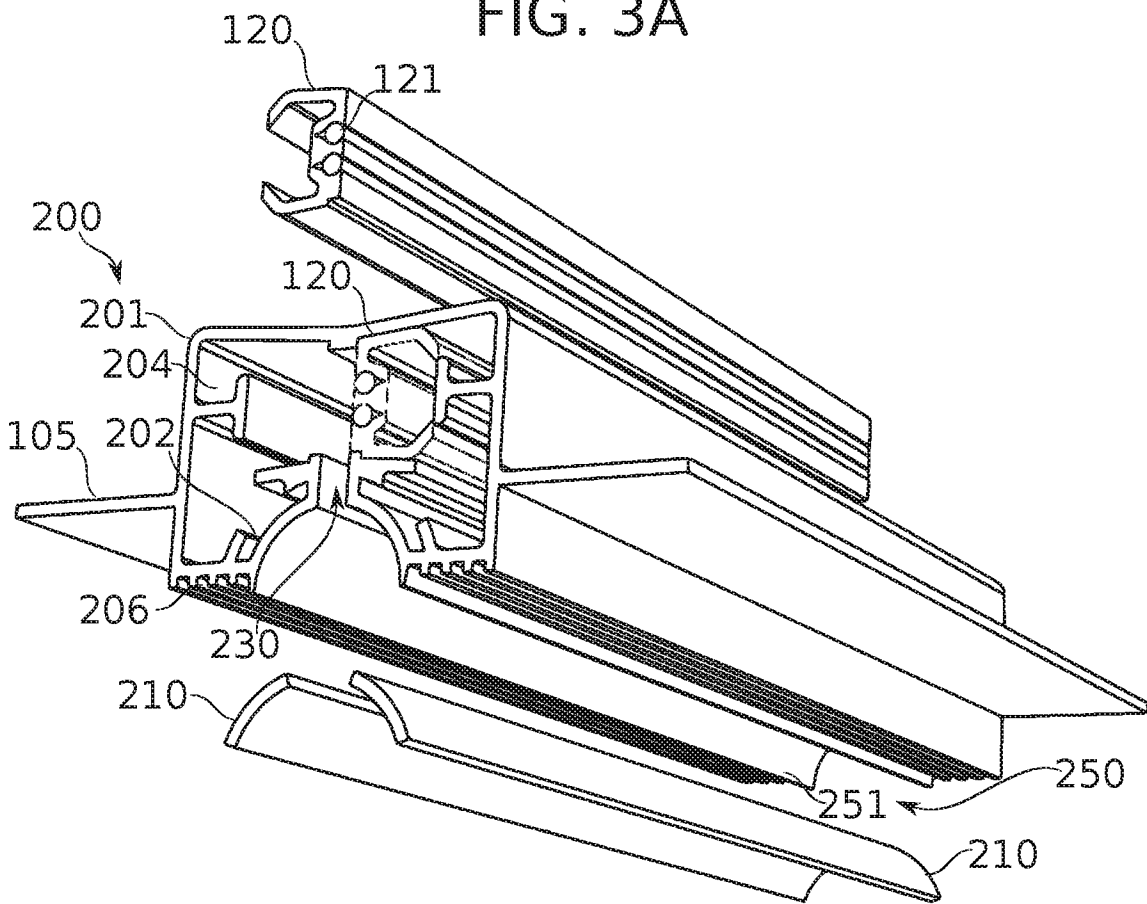

FIG. 3B

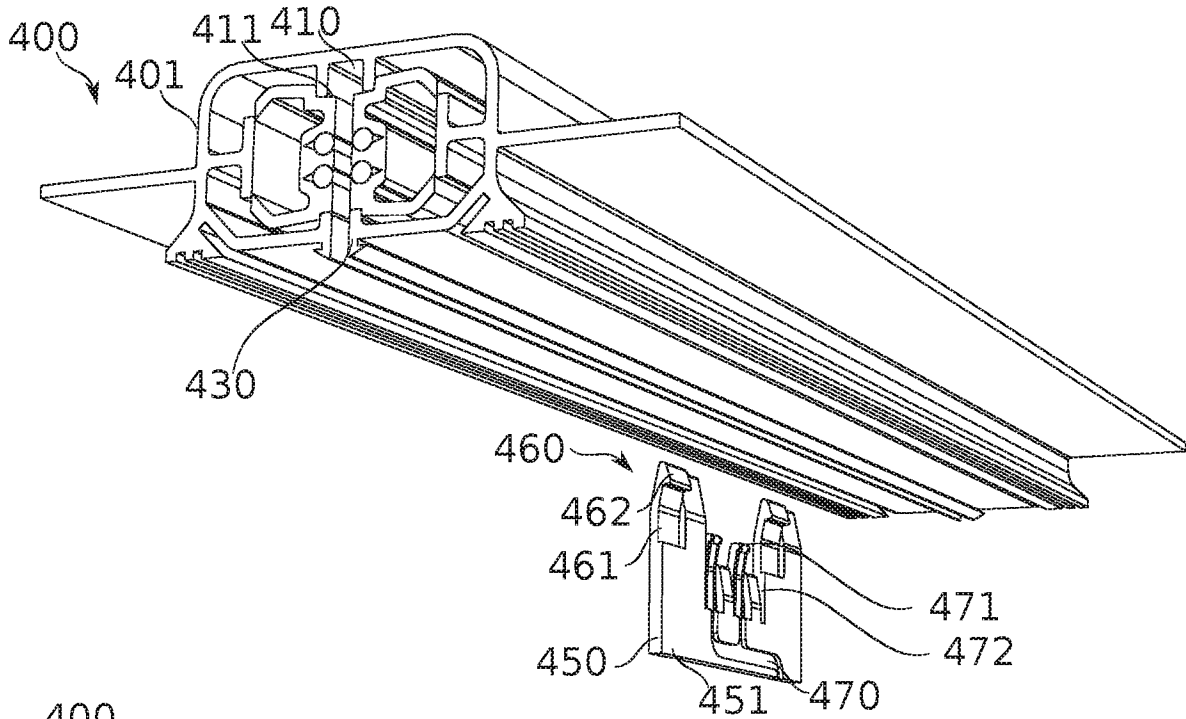

FIG. 4A

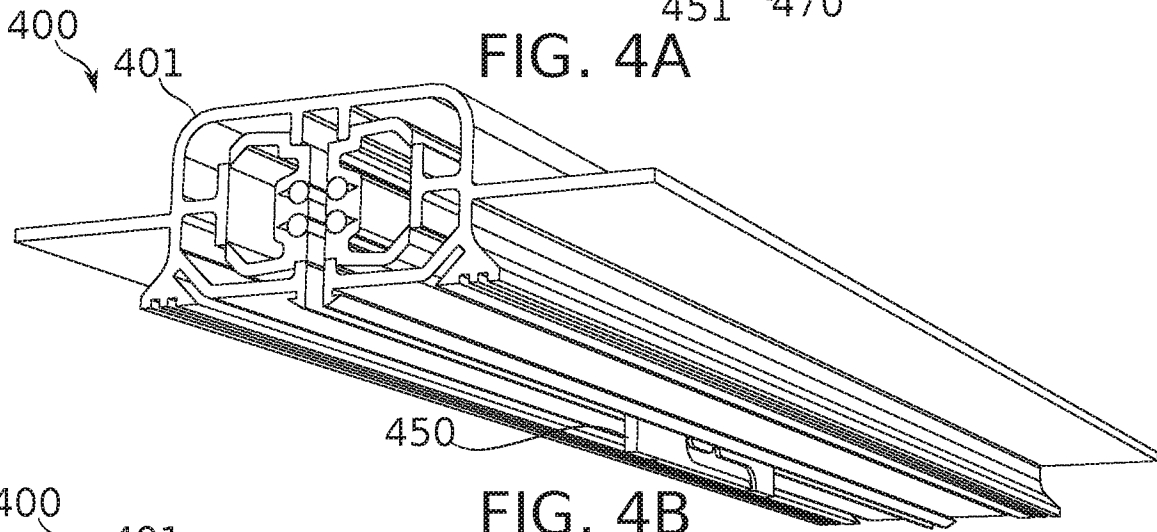

FIG. 4B

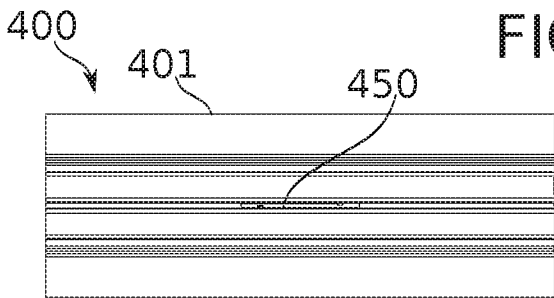

FIG. 4C

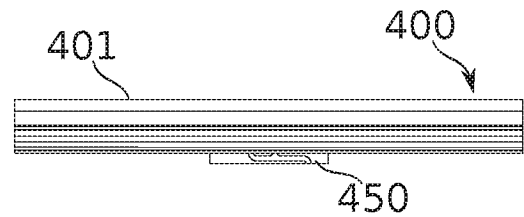

FIG. 4D

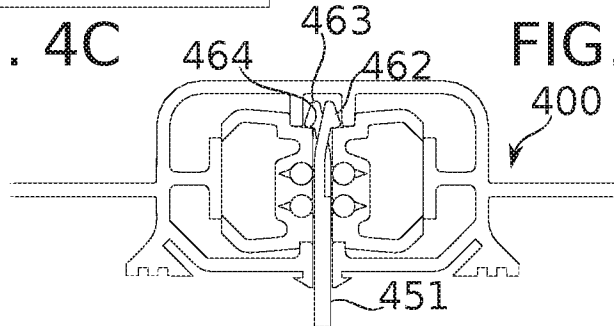

FIG. 4E

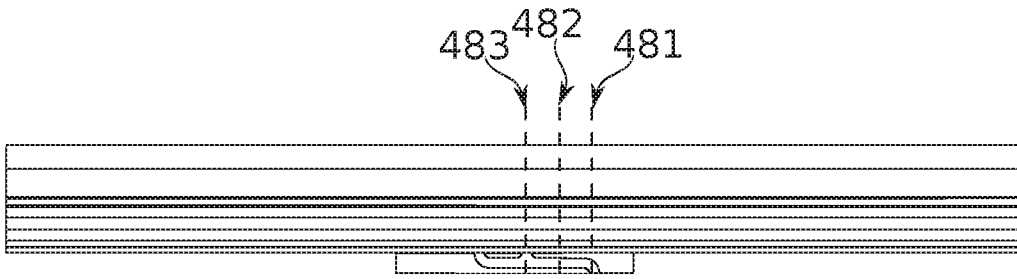

FIG. 4F

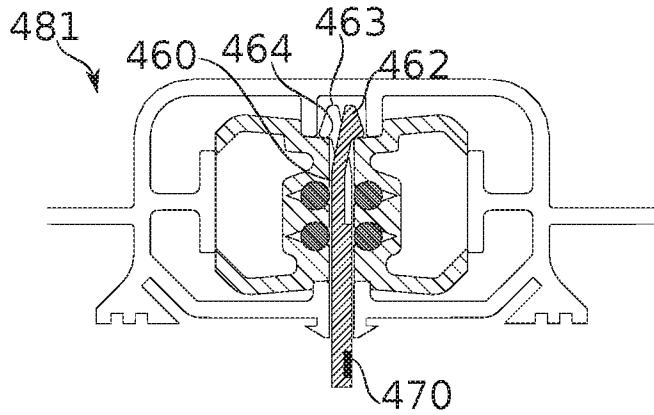

FIG. 4G

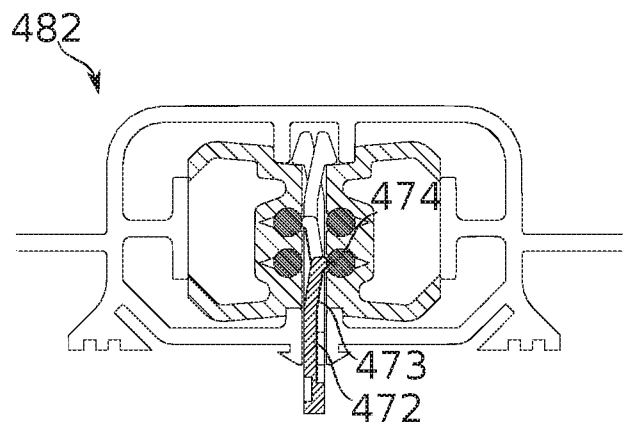

FIG. 4H

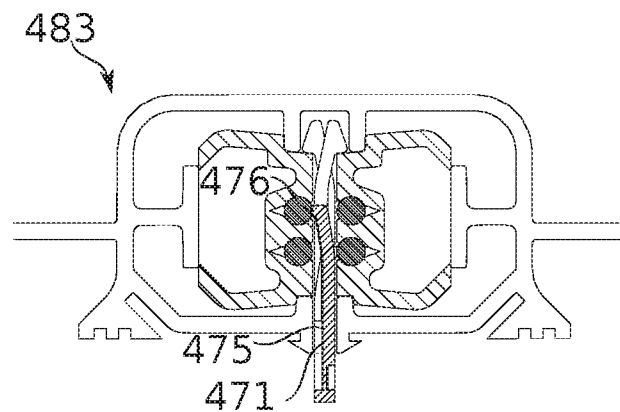

FIG. 4I

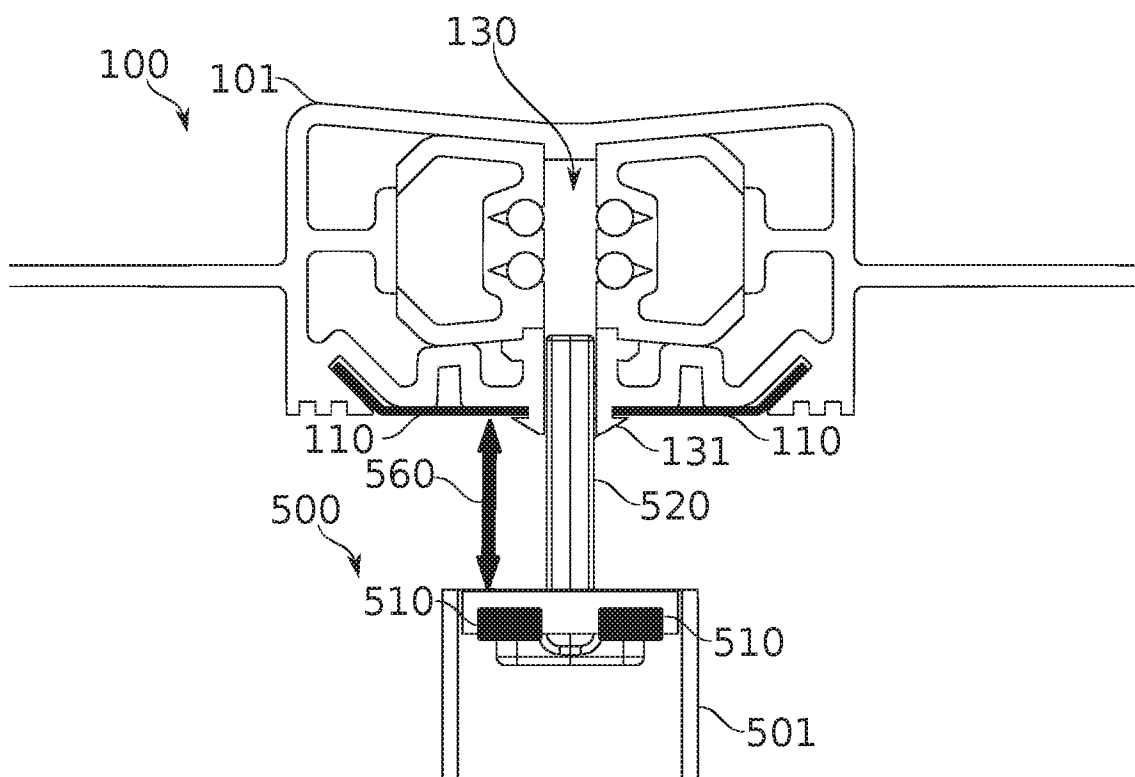

FIG. 5A

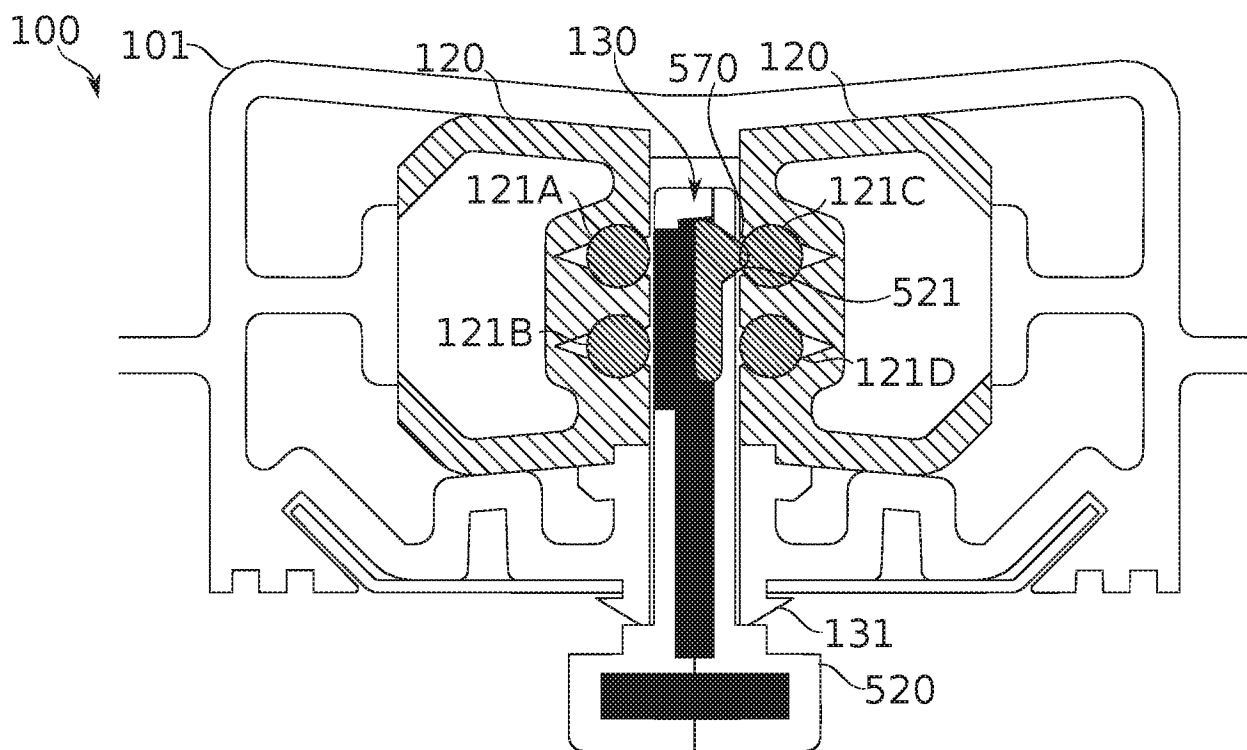

FIG. 5B

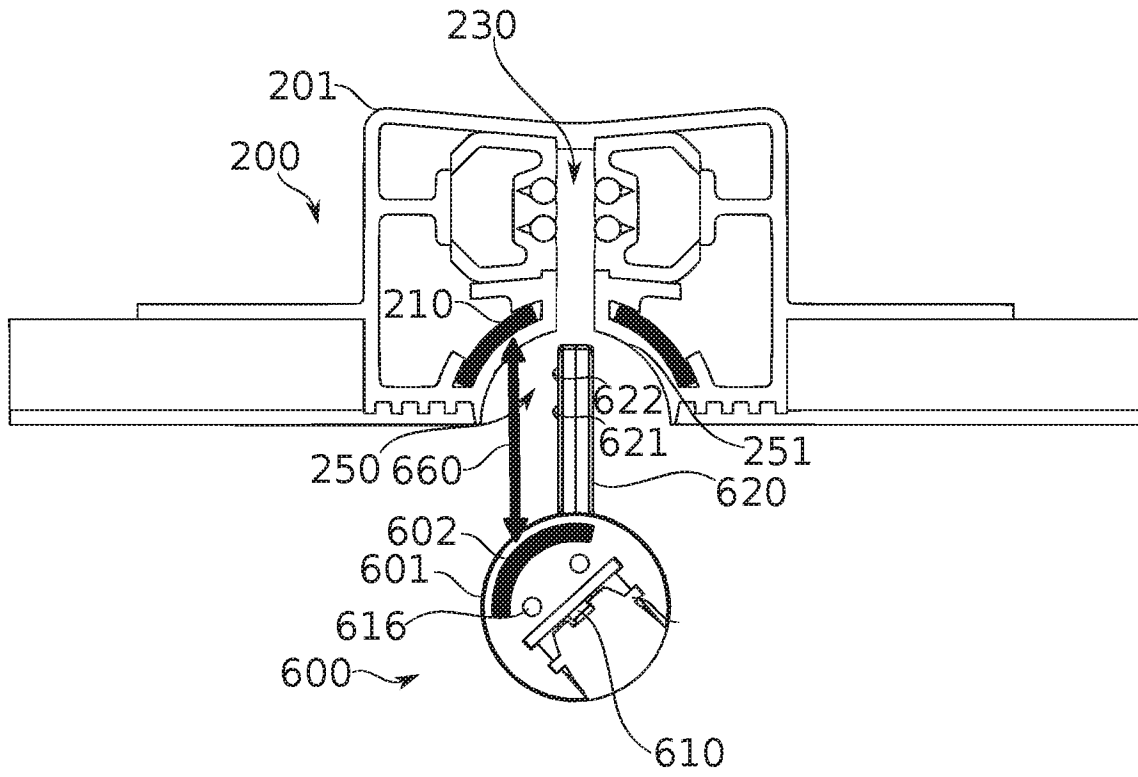

FIG. 5C

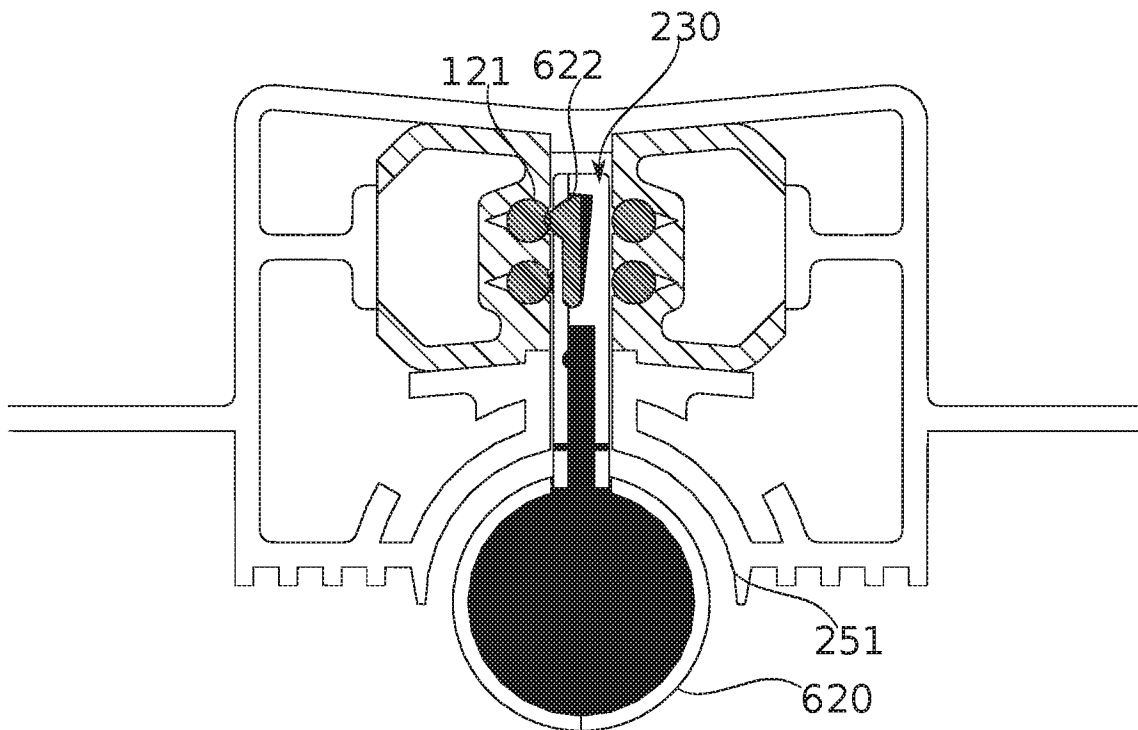

FIG. 5D

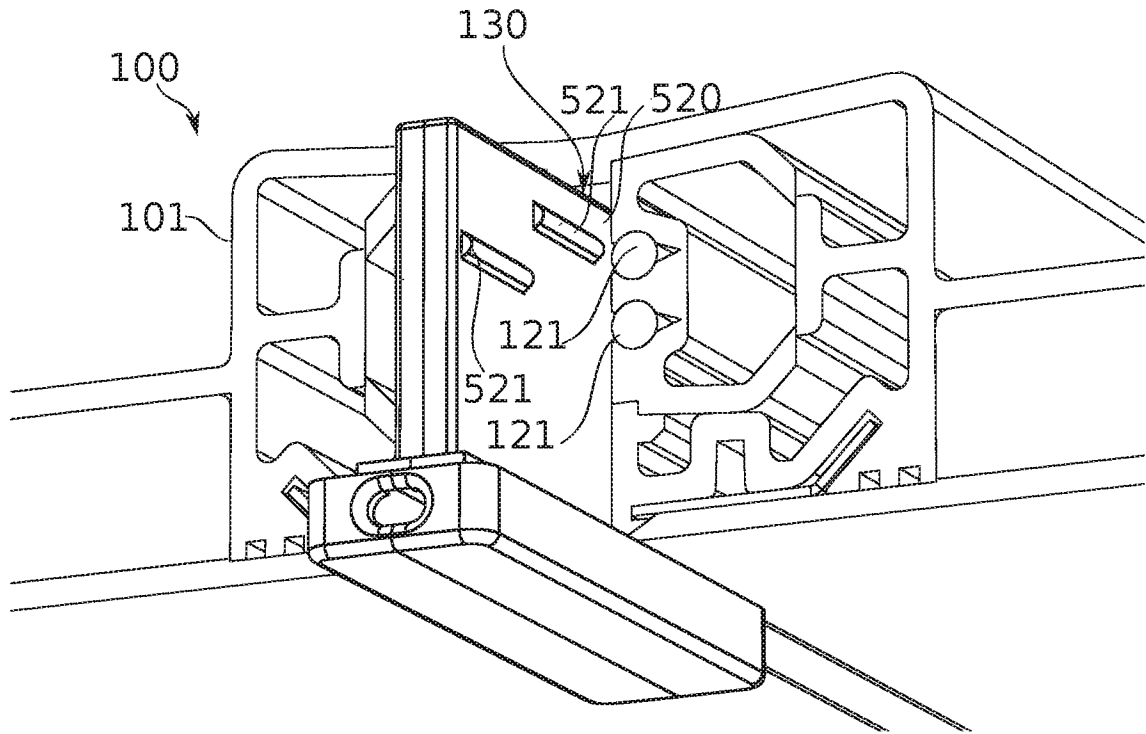

FIG. 6

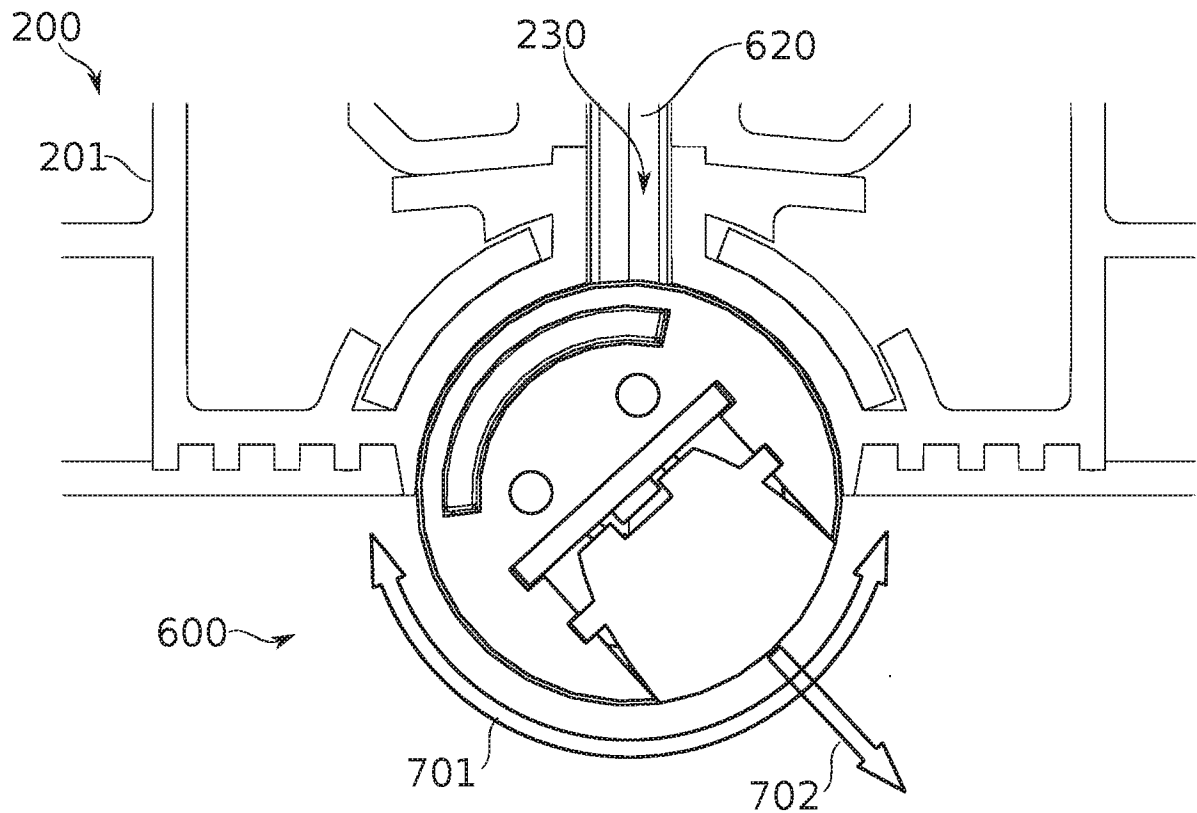

FIG. 7

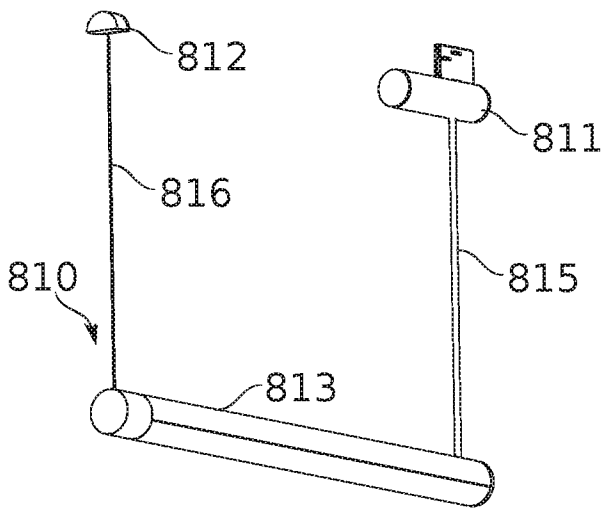

FIG. 8A

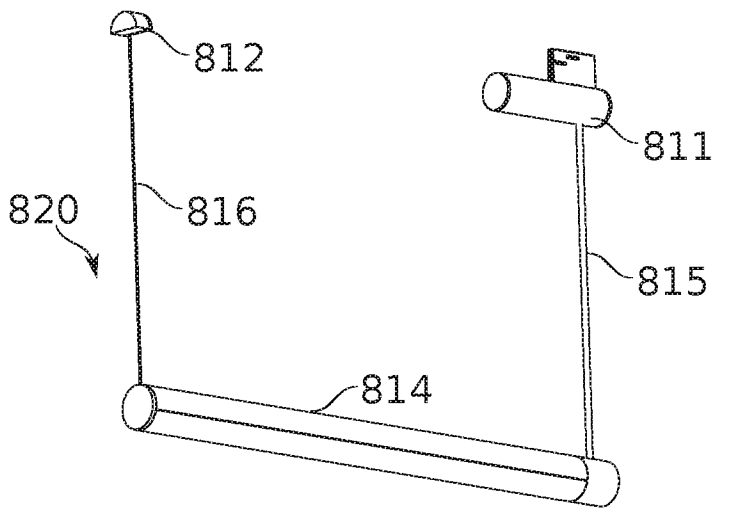

FIG. 8B

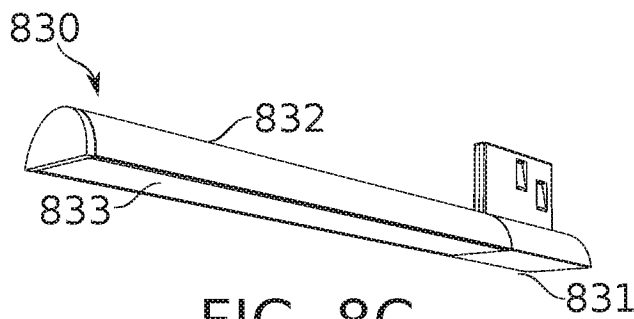

FIG. 8C

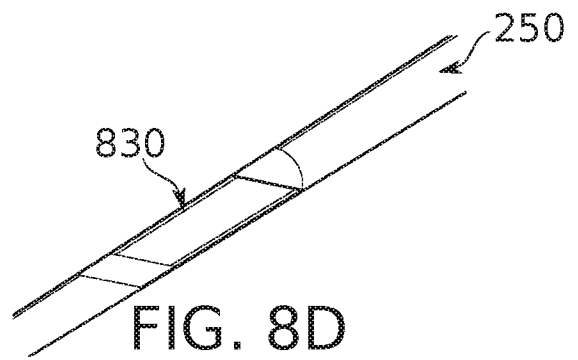

FIG. 8D

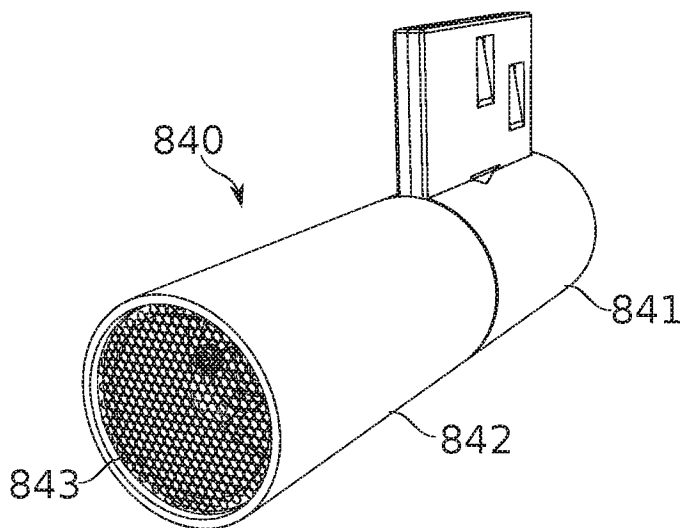

FIG. 8E

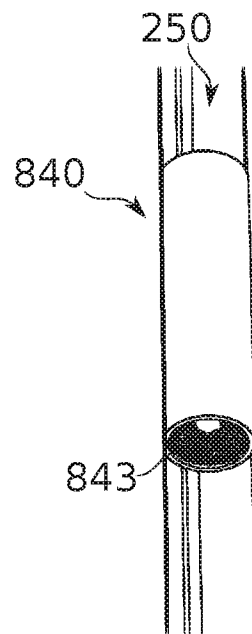

FIG. 8F

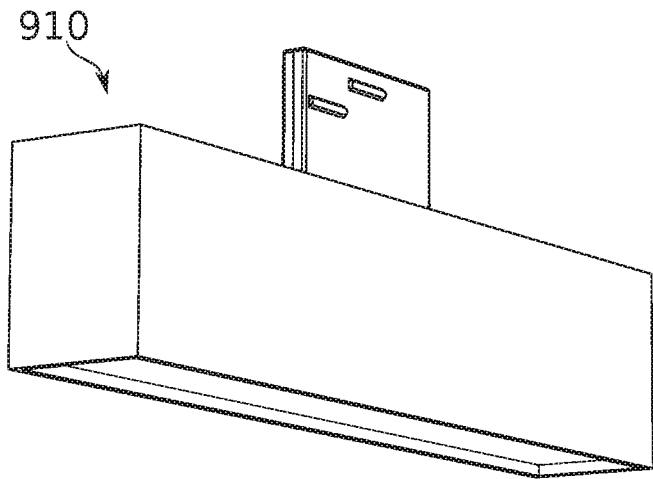

FIG. 9A

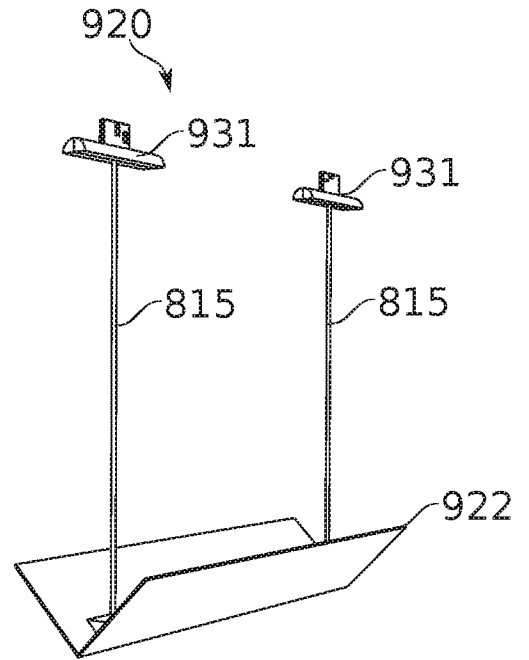

FIG. 9B

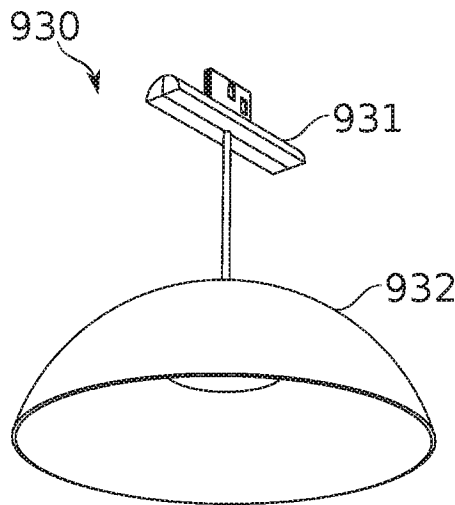

FIG. 9C

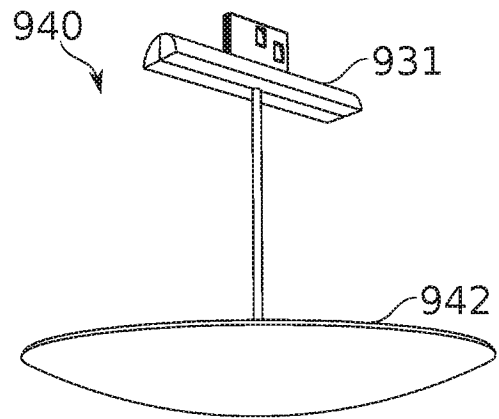

FIG. 9D

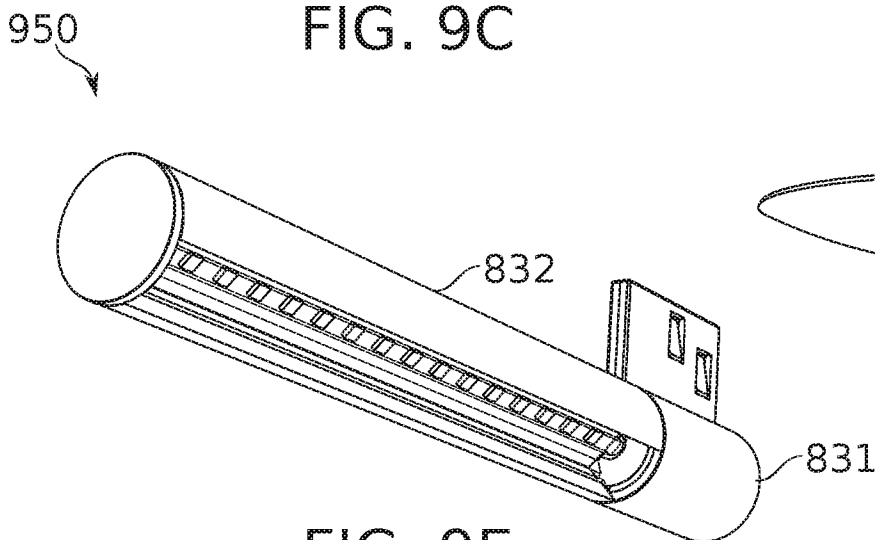

FIG. 9E

INTERNATIONAL SEARCH REPORT

International application No
PCT/IL2016/050189

A. CLASSIFICATION OF SUBJECT MATTER
 INV. F21V21/35 H01R25/14 F21V21/30
 ADD. F21S8/02 F21V21/04 F21S8/06

According to International Patent Classification (IPC) or to both national classification and IPC

B. FIELDS SEARCHED
 Minimum documentation searched (classification system followed by classification symbols)
 F21S F21V H01R

Documentation searched other than minimum documentation to the extent that such documents are included in the fields searched

Electronic data base consulted during the international search (name of data base and, where practicable, search terms used)
 EPO-Internal, WPI Data

C. DOCUMENTS CONSIDERED TO BE RELEVANT

Category*	Citation of document, with indication, where appropriate, of the relevant passages	Relevant to claim No.
X	US 2006/262521 A1 (PIEPGRAS COLIN [US] ET AL) 23 November 2006 (2006-11-23)	1-3, 6-12,17, 18, 22-33, 36-41
Y	paragraph [0068] figures 8, 10a, 11,12	34
X	US 8 851 717 B2 (VERBRUGH STEFAN MARCUS [NL]) 7 October 2014 (2014-10-07)	1-8,11, 13-25, 40-42
Y	column 6, line 34 - line 44 column 10, line 7 - line 36 column 13, line 16 - column 14, line 21 column 15, line 8 - line 38 figures 1,2,4A,5A,6B ----- -/--	34

Further documents are listed in the continuation of Box C.

See patent family annex.

* Special categories of cited documents :

"A" document defining the general state of the art which is not considered to be of particular relevance

"E" earlier application or patent but published on or after the international filing date

"L" document which may throw doubts on priority claim(s) or which is cited to establish the publication date of another citation or other special reason (as specified)

"O" document referring to an oral disclosure, use, exhibition or other means

"P" document published prior to the international filing date but later than the priority date claimed

"T" later document published after the international filing date or priority date and not in conflict with the application but cited to understand the principle or theory underlying the invention

"X" document of particular relevance; the claimed invention cannot be considered novel or cannot be considered to involve an inventive step when the document is taken alone

"Y" document of particular relevance; the claimed invention cannot be considered to involve an inventive step when the document is combined with one or more other such documents, such combination being obvious to a person skilled in the art

"&" document member of the same patent family

Date of the actual completion of the international search 10 June 2016	Date of mailing of the international search report 20/06/2016
---	--

Name and mailing address of the ISA/ European Patent Office, P.B. 5818 Patentlaan 2 NL - 2280 HV Rijswijk Tel. (+31-70) 340-2040, Fax: (+31-70) 340-3016	Authorized officer Dinkla, Remko
--	---

INTERNATIONAL SEARCH REPORT

International application No
PCT/IL2016/050189

C(Continuation). DOCUMENTS CONSIDERED TO BE RELEVANT		
Category*	Citation of document, with indication, where appropriate, of the relevant passages	Relevant to claim No.
X	US 2009/168423 A1 (MILLER JACK V [US]) 2 July 2009 (2009-07-02) figures 2,3 -----	1-3, 6-10, 28-33,35
X	WO 2014/137142 A1 (LINNO LTD [KR]) 12 September 2014 (2014-09-12) figures 4,5,11,18 -& US 2015/226384 A1 (PARK HYUN YONG [KR]) 13 August 2015 (2015-08-13) -----	1,6-12, 18, 22-27, 29-33, 35-41
X A	US 2009/080202 A1 (FRIEDMAN ROBERT E [US]) 26 March 2009 (2009-03-26) paragraphs [0021], [0022], [0043], [0047], [0048] figures 1,2 -----	26-33, 35-39 6,8-10

INTERNATIONAL SEARCH REPORT

Information on patent family members

International application No PCT/IL2016/050189

Patent document cited in search report	Publication date	Patent family member(s)	Publication date
US 2006262521	A1	23-11-2006	EP 1891371 A2 27-02-2008
			US 2006262521 A1 23-11-2006
			US 2012044670 A1 23-02-2012
			WO 2006127666 A2 30-11-2006

US 8851717	B2	07-10-2014	CN 102333989 A 25-01-2012
			EP 2401547 A1 04-01-2012
			JP 5530462 B2 25-06-2014
			JP 2012518882 A 16-08-2012
			US 2012075857 A1 29-03-2012
			WO 2010097733 A1 02-09-2010

US 2009168423	A1	02-07-2009	NONE

WO 2014137142	A1	12-09-2014	CN 104662364 A 27-05-2015
			EP 2966347 A1 13-01-2016
			JP 2015533017 A 16-11-2015
			KR 101351358 B1 23-01-2014
			US 2015226384 A1 13-08-2015
			WO 2014137142 A1 12-09-2014

US 2015226384	A1	13-08-2015	CN 104662364 A 27-05-2015
			EP 2966347 A1 13-01-2016
			JP 2015533017 A 16-11-2015
			KR 101351358 B1 23-01-2014
			US 2015226384 A1 13-08-2015
			WO 2014137142 A1 12-09-2014

US 2009080202	A1	26-03-2009	NONE
