

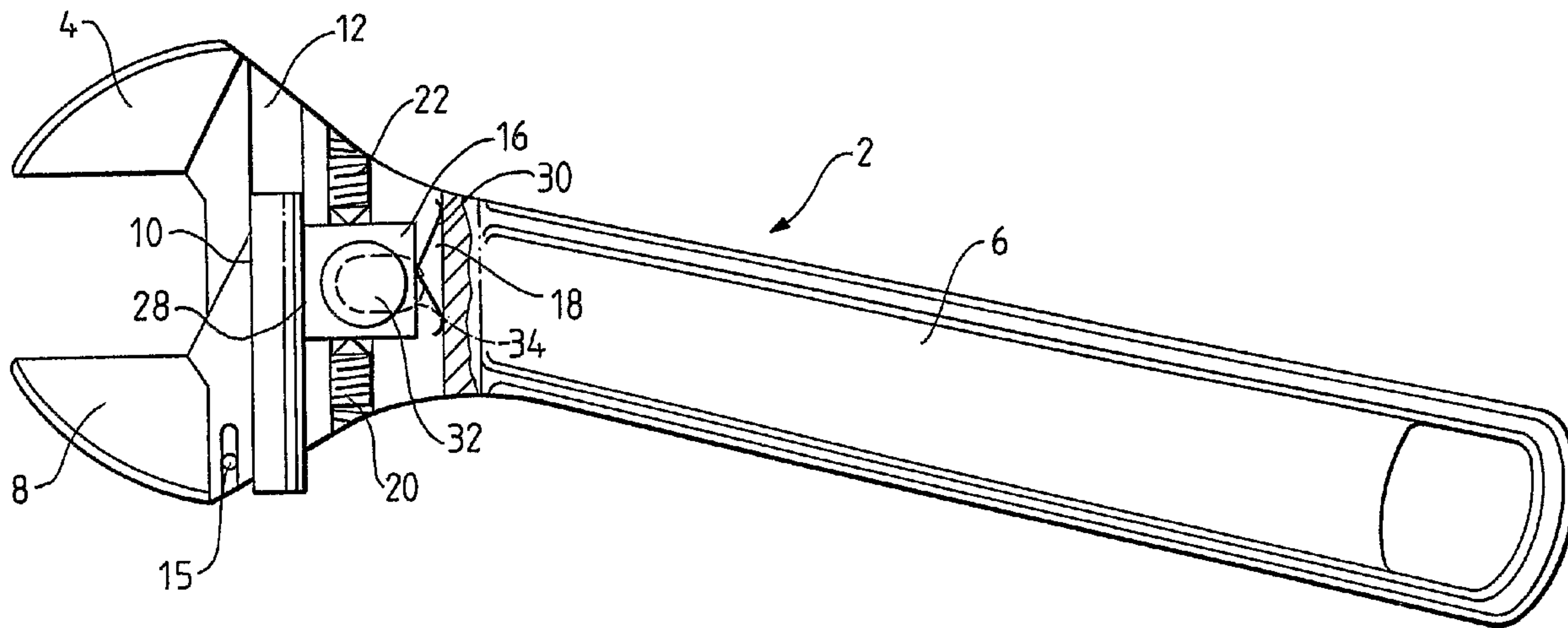

(86) Date de dépôt PCT/PCT Filing Date: 2002/08/22
 (87) Date publication PCT/PCT Publication Date: 2003/03/06
 (45) Date de délivrance/Issue Date: 2011/04/26
 (85) Entrée phase nationale/National Entry: 2004/02/24
 (86) N° demande PCT/PCT Application No.: GB 2002/003878
 (87) N° publication PCT/PCT Publication No.: 2003/018262
 (30) Priorité/Priority: 2001/08/24 (GB0120603.6)

(51) Cl.Int./Int.Cl. *B25B 13/20* (2006.01),
B25B 13/12 (2006.01), *B25B 13/22* (2006.01)
 (72) Inventeur/Inventor:
HARRISON, IAN AUSTIN, GB
 (73) Propriétaire/Owner:
HTM PRODUCTS LTD., GB
 (74) Agent: OGILVY RENAULT LLP/S.E.N.C.R.L.,S.R.L.

(54) Titre : CLE A MOLETTE
 (54) Title: ADJUSTABLE SPANNER



(57) Abrégé/Abstract:

The present invention relates to an adjustable spanner (2) having a first fixed jaw (4) and a second moveable jaw (8). The second jaw (8) can be locked in fixed relation to the first jaw (4) by a locking means (16). This locking means (16) is moveable between a first position in which the second jaw (8) is fixed in relation to the first jaw (4) and a second position in which the second jaw (8) is permitted to move with respect to the first jaw (4).

(12) INTERNATIONAL APPLICATION PUBLISHED UNDER THE PATENT COOPERATION TREATY (PCT)

(19) World Intellectual Property Organization
International Bureau



(43) International Publication Date
6 March 2003 (06.03.2003)

PCT

(10) International Publication Number
WO 03/018262 A1

- (51) International Patent Classification⁷: **B25B 13/20**, 13/22
- (21) International Application Number: PCT/GB02/03878
- (22) International Filing Date: 22 August 2002 (22.08.2002)
- (25) Filing Language: English
- (26) Publication Language: English
- (30) Priority Data:
0120603.6 24 August 2001 (24.08.2001) GB
- (71) Applicant (for all designated States except US): **HTM PRODUCTS LTD.** [GB/GB]; Glebe House, Furners Mead, Henfield BN5 9JA (GB).
- (72) Inventor; and
- (75) Inventor/Applicant (for US only): **HARRISON, Ian, Austin** [GB/GB]; Basement Flat, 27 Charles Road, St. Leonards On Sea, TN38 0QH (GB).
- (74) Agent: **LECKEY, David, Herbert**; Frank B. Dehn & Co., 179 Queen Victoria Street, London EC4V 4EL (GB).
- (81) Designated States (*national*): AE, AG, AL, AM, AT (utility model), AT, AU, AZ, BA, BB, BG, BR, BY, BZ, CA, CH, CN, CO, CR, CU, CZ (utility model), CZ, DE (utility model), DE, DK (utility model), DK, DM, DZ, EC, EE (utility model), EE, ES, FI (utility model), FI, GB, GD, GE, GH, GM, HR, HU, ID, IL, IN, IS, JP, KE, KG, KP, KR, KZ, LC, LK, LR, LS, LT, LU, LV, MA, MD, MG, MK, MN, MW, MX, MZ, NO, NZ, OM, PH, PL, PT, RO, RU, SD, SE, SG, SI, SK (utility model), SK, SL, TJ, TM, TN, TR, TT, TZ, UA, UG, US, UZ, VC, VN, YU, ZA, ZM, ZW.
- (84) Designated States (*regional*): ARIPO patent (GH, GM, KE, LS, MW, MZ, SD, SL, SZ, TZ, UG, ZM, ZW), Eurasian patent (AM, AZ, BY, KG, KZ, MD, RU, TJ, TM), European patent (AT, BE, BG, CH, CY, CZ, DE, DK, EE, ES, FI, FR, GB, GR, IE, IT, LU, MC, NL, PT, SE, SK, TR), OAPI patent (BF, BJ, CF, CG, CI, CM, GA, GN, GQ, GW, ML, MR, NE, SN, TD, TG).
- Published:**
— with international search report
- For two-letter codes and other abbreviations, refer to the "Guidance Notes on Codes and Abbreviations" appearing at the beginning of each regular issue of the PCT Gazette.*

(54) Title: ADJUSTABLE SPANNER

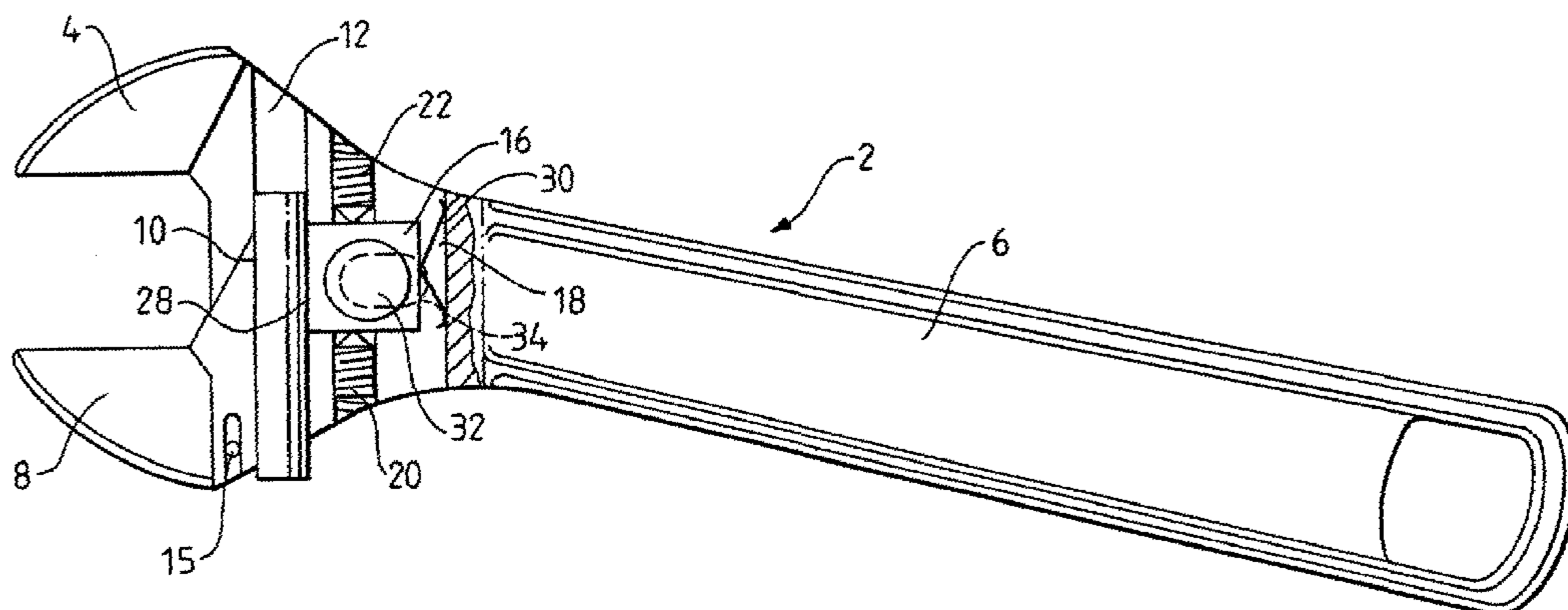

(57) Abstract: The present invention relates to an adjustable spanner (2) having a first fixed jaw (4) and a second moveable jaw (8). The second jaw (8) can be locked in fixed relation to the first jaw (4) by a locking means (16). This locking means (16) is moveable between a first position in which the second jaw (8) is fixed in relation to the first jaw (4) and a second position in which the second jaw (8) is permitted to move with respect to the first jaw (4).



WO 03/018262 A1

ADJUSTABLE SPANNER

5 This invention relates to an adjustable spanner.
Adjustable spanners are well known, and have been
used for many years. Typically they comprise a fixed
jaw, which is mounted to or formed integrally with a
handle, and a moving jaw slidably mounted relative to
10 the fixed jaw. Adjustment is made by means of a worm
screw which engages a rack formed on the movable jaw.
The problem with this arrangement is that it is
cumbersome to use, being difficult to set in situ, and
also that it may loosen during use. This frequently
15 results in the spanner slipping from the nut, damaging
the nut and sometimes also causing injury to the user's
knuckles.

The present invention seeks to overcome or at least
alleviate the above problems, and from a first aspect it
20 provides an adjustable spanner comprising:

a first jaw;

a second jaw mounted for slidable movement relative
to said first jaw;

a locking member movable between a locking position
25 in which it engages said second jaw so as to lock the
second jaw in position relative to the first jaw and a
release position in which it releases said second jaw;

biasing means for biasing the locking member
towards its locking position; and

30 release means for moving said locking member out of
said locking position towards its release position
against the force of said biasing means.

In accordance with the invention, therefore, a
locking member is biased towards a locking position by
35 biasing means. Release means are provided which allow
the locking member to be disengaged from the slidable
jaw so as to allow the position of the jaw to be

adjusted. Once the jaw is in the desired position, the release means can be released and the jaw then locked in position.

5 Preferably the locking member and said second jaw have interlocking formations which lock the second jaw in position relative to the first jaw in the event that a force is applied to the second jaw in a direction which tends to increase the separation between the jaws.

10 Preferably the interlocking formations comprise one or more ratchet teeth provided on the jaw and/or the locking member. With such an arrangement, the tooth or teeth provided on the second jaw can move over the tooth or teeth provided on the locking member relatively easily when the second jaw is moving towards the first
15 jaw to facilitate adjustment. However, when the jaws are in position over a nut, then rotation of the spanner will tend to push the teeth further into engagement, preventing slippage. Most preferably teeth extend along opposed surfaces of the second jaw and the locking
20 member.

Preferably the locking member is arranged to move in a direction generally perpendicular to the direction of movement of the second jaw.

25 Most preferably the locking member is arranged in a slot which extends in the head of the spanner. Although this slot could extend generally perpendicular to the direction of movement of the second jaw, in the preferred embodiment, the slot extends through the head of the spanner in a direction generally parallel to the
30 direction of movement of the second jaw. Suitable means may be provided for preventing the locking member from falling out of the slot.

35 In a preferred embodiment, there are provided means for adjustably positioning the locking member within the slot. This is advantageous in that it potentially allows imperial and metric nuts to be gripped tightly. If for example the locking member and sliding jaw are

provided with metric spaced teeth, they will allow the jaws closely to grip metric nuts. However, they will not, potentially, allow as firm a grip on imperial nuts, as the spacing between the jaws set for metric nuts may not precisely correspond with the imperial nut size. By being able to adjust the position of the locking member, this difference can be absorbed.

This is an advantageous arrangement in its own right, and may have application to other spanner constructions, so from a further aspect the invention provides an adjustable spanner comprising:

a first jaw;

a second jaw mounted for slidable movement relative to said first jaw;

a locking member movable between a locking position in which it engages said second jaw so as to lock the second jaw in position relative to the first jaw and a release position in which it releases said second jaw;

a slot which receives said locking member and which extends through the head of the spanner in a direction generally parallel to the direction of movement of the second jaw ; and

means for adjustably positioning the locking member within the slot.

Preferably the positioning means comprise adjustment screws, and most preferably the adjustment screws are received in a threaded bore extending along the slot receiving the locking member.

Preferably the biasing means of the spanner comprises a spring. The spring need not be of sufficient strength to push the locking member fully home into its locking position but it should bias it towards that position.

The spring may take any suitable form, for example a coil spring, a wire spring or so on. Preferably, however, the spring is a leaf spring. The leaf spring may, for example be bow shaped or generally V-shaped

such that as the locking member acts on the spring it deforms.

Suitable means may be provide on the spanner head to locate the biasing means. Preferably, however, the locking member comprises means for locating said biasing means. Such means may comprise, for example a notch or recess receiving a projection formed on the biasing means.

Turning now to the release means, preferably the release means comprises a release member coupled to the locking member and which extends from the spanner for operation by a user. Depending on the strength of the biasing means the release member can also be used to assist the biasing means in locking the locking member in position by a user pushing it in the locking direction.

Preferably the release member comprises a button which extends through an opening such as a slot in a face of the spanner head and which is movable in the direction away from the second jaw to release the locking means.

Preferably the button is screw fitted onto said locking member through said slot.

From a further aspect, the invention provides an adjustable spanner comprising:

a first jaw;

a second jaw mounted for slidable movement relative to said first jaw;

a locking member movable between a locking position in which it engages said second jaw so as to lock the second jaw in position relative to the first jaw and a release position in which it releases said second jaw;

means for moving the locking member between its locking and release positions, said means comprising a member coupled to the locking member and extending out through an opening in a face of the spanner head for manipulation by a user.

Two preferred embodiments of the present invention will now be described by way of example only and with reference to the accompanying drawings wherein:

- 5 Figure 1 shows a side view of a first embodiment of the invention in partial section;
Figure 2 shows a top view of the spanner;
Figure 3 shows an enlarged view of the teeth profile;
and
10 Figure 4 shows a side view of a second embodiment of the invention.

With reference to Figure 1 there is shown an adjustable spanner 2 having a first jaw 4, integral with the
15 handle 6 and second jaw 8 slidable with respect to the first jaw 4. The second jaw 8 has a spigot 10 which is slidably mounted within a bore 12 formed in the head 14 of the spanner 2. The slidable jaw 8 is prevented from falling out by a stop screw 15.

20 A generally rectangular locking member 16 is moveable in a direction perpendicular to the direction of movement of the second jaw 8 from a locking position in which it engages the second jaw 8 to lock the second jaw 8 in a position relative to the first jaw 4 and a
25 release position in which it releases the second jaw 8.

As can be seen from Figure 2, the locking member 16 is mounted within a slot 18 extending through the head of the spanner in a direction parallel to the direction of movement of the second jaw 8. The locking member 16
30 is positioned in a desired position along the slot by virtue of two set screws 20, 22 which are received in a threaded bore 24 extending along the length of the slot 18.

The opposed faces of the locking member 16 and the
35 sliding jaw 8 are provided with sets of interlocking ratchet-like teeth 26, as illustrated in Figure 3 which engage at the interface 28. The pitch of the teeth 28

may be set at metric, imperial or any other measuring system. By setting the teeth pitch to match a pre-determined measuring system, a correct fit will be ensured with a nut sized in the same system. It can be
5 seen from Figure 3 that the teeth 28 may have a slight backward slope generally which tends to force the locking member 16 further into engagement with the second jaw 8 when a force tending to separate the jaws 4, 8 is applied at the work face, leading to improved
10 grip and preventing slippage of the spanner in use.

A bow spring 30 is arranged in the slot 18 behind the locking member 16 so as to bias the sliding jaw 8 into its locking position with the teeth 26 of the jaw 8 and locking member 16 engaged. The spring 30 also acts
15 to maintain the teeth 26 interengaged while the spanner is in use, preventing loosening of the spanner.

A release button 32 is provided which permits the locking member 16 to be released against the biasing force of the spring 30. The release button 32 is
20 fastened e.g. screwed to the locking member 16 and protrudes through a slot 34 in a face of the spanner head 14 as shown in Figure 2.

In operation, to fit the spanner 2 to a particular nut size, the release button 32 is pulled back in a
25 direction away from the sliding jaw 8 so as to disengage the teeth 26 along the interface 28. In this condition, the jaw 8 can slide freely within the bore 12 and if held in the correct orientation will fall back against the stop screw 11. The spanner can then be placed over
30 a nut and closed onto the nut by finger pressure. In fact, in order to reduce the gap between the jaws 4, 8 it may not be necessary to pull back the release button 32 as the teeth may move over each other when pushed in this direction.

35 When the correct size has been reached, the button 32 is released and the teeth 26 move into engagement under the force of the spring 30 and/or by the button 32

being pushed back in that direction.

This firmly locks the locking member against the sliding jaw 8 and thus locks the sliding jaw 8 relative to the fixed jaw 4. When the spanner 2 is rotated in either direction the force generated tends to drive the teeth 26 further into engagement thereby maintaining pressure on the interface and maintaining the locking effect and grip.

If due to the pitch of the teeth 26 a firm grip cannot be obtained on a nut (for example if a metric pitch spanner is used on an imperial size nut, then the set screws 20, 22 can be loosened and tightened to move the locking member 16 slightly in the slot 18 thereby moving the sliding jaw 8 closer to or further away from the fixed jaw 4.

A second embodiment of the invention is shown in Figure 4. This is generally similar to the embodiment of Figure 1, so only the differences will be described here.

In this embodiment, the locking member 38 has a notch 40 formed in its rear surface for receiving a complementary projection 42 formed in a generally V-shaped spring 44. This notch 40 locates the spring in the slot 46 preventing it falling out.

It will be seen from the above description that the spanner described solves the problems found in the conventional adjustable spanner by locking the jaws precisely to the nut size through the action of the teeth gripping at the interface. The spanner can also very easily be set to another nut size.

WHAT IS CLAIMED IS:

1. An adjustable spanner comprising:

a first jaw;

a second jaw mounted for slidable movement relative to said first jaw;

a locking member movable between a locking position in which it engages said second jaw so as to lock the second jaw in position relative to the first jaw and a release position in which it releases said second jaw;

biasing means for biasing the locking member towards its locking position; and

release means for moving said locking member out of said locking position towards its release position against the force of said biasing means;

said locking member and said second jaw having interlocking ratchet teeth provided thereon;

said ratchet teeth extending along opposed surfaces of the second jaw and the locking member;

characterised in that the said opposed surfaces are parallel to the direction of movement of the second jaw; and in that

said ratchet teeth are backwardly sloped relative to the opposed surfaces, such that in the event that a force is applied to the second jaw in a direction which tends to increase the separation between the jaws the teeth act to force the locking member and the second jaw further into engagement in said locking position.

2. An adjustable spanner as claimed in claim 1, wherein said locking member is arranged to move in a direction generally perpendicular to the direction of movement of the second jaw.

3. An adjustable spanner as claimed in claim 2 wherein said locking member is arranged in a slot which extends through the head of the spanner.
4. An adjustable spanner as claimed in claim 3 wherein said slot extends generally parallel to the direction of movement of the second jaw.
5. An adjustable spanner as claimed in claim 4 comprising means for adjustably positioning said locking member within the slot.
6. An adjustable spanner as claimed in claim 5 wherein said positioning means comprise adjustment screws.
7. An adjustable spanner as claimed in claim 6 wherein said adjustment screws are received in a threaded bore extending along said slot.
8. An adjustable spanner as claimed in any one of claims 1 to 7, wherein the biasing means comprises a spring.
9. An adjustable spanner as claimed in claim 8, wherein said spring is a coil spring.
10. An adjustable spanner as claimed in claim 8 wherein said spring is a leaf spring.
11. An adjustable spanner as claimed in claim 10 wherein said leaf spring is bow shaped.
12. An adjustable spanner as claimed in claim 10 wherein said leaf spring is generally V-shaped.
13. An adjustable spanner as claimed in any one of claims 1 to 12, wherein said locking member comprises means for locating said biasing means.

14. An adjustable spanner as claimed in claim 13 wherein said location means comprises a notch for receiving a projection formed on the biasing means.

15. An adjustable spanner as claimed in any one of claims 1 to 14, wherein said release means comprises a release member coupled to the locking member and which extends from the spanner for operation by a user.

16. An adjustable spanner as claimed in claim 15 wherein the release member comprises a button which extends through a slot in a face of the spanner head and which is movable in the direction away from the second jaw to release the locking means.

17. An adjustable spanner as claimed in claim 16 wherein said button is screw fitted onto said locking member through said slot.

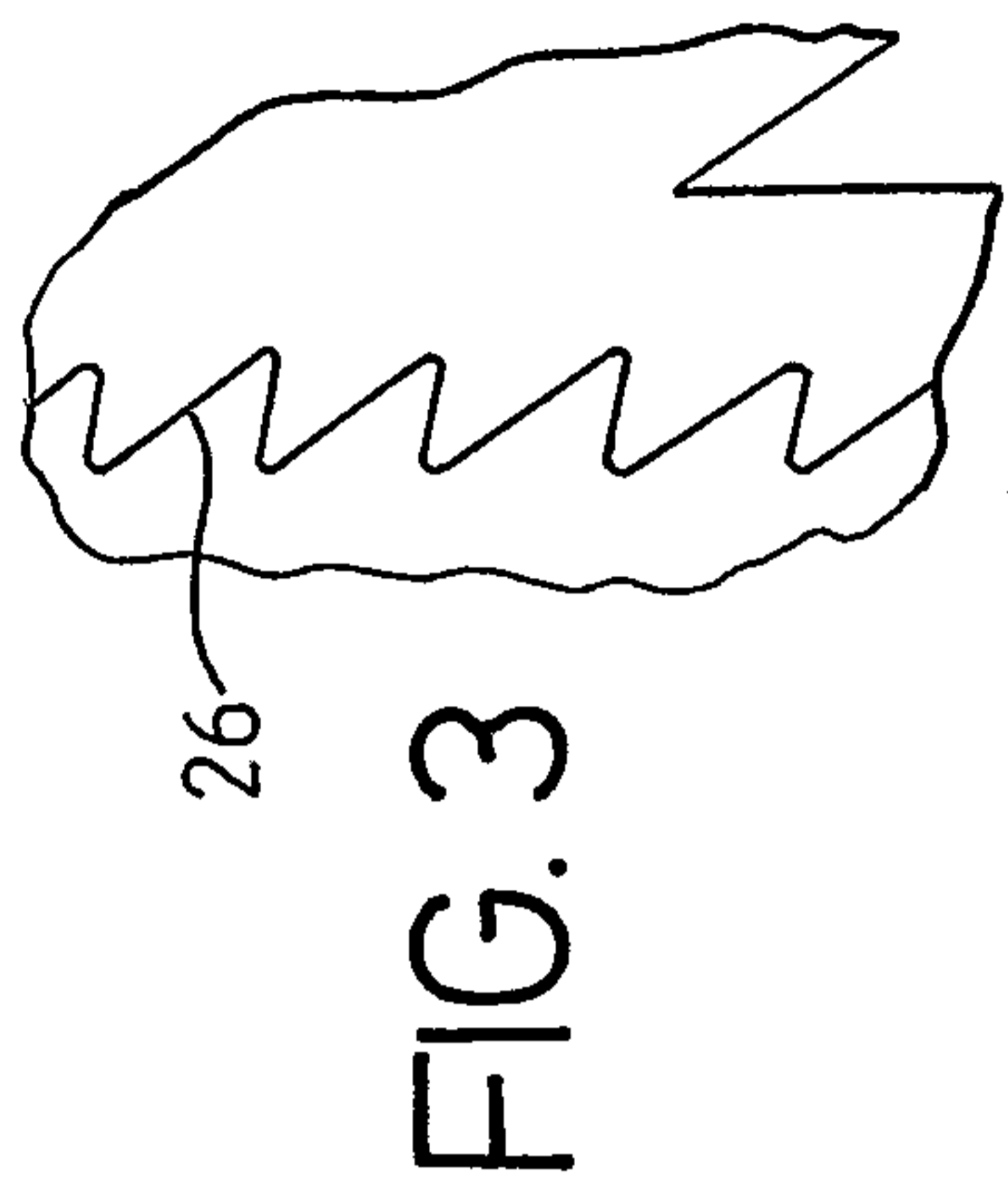
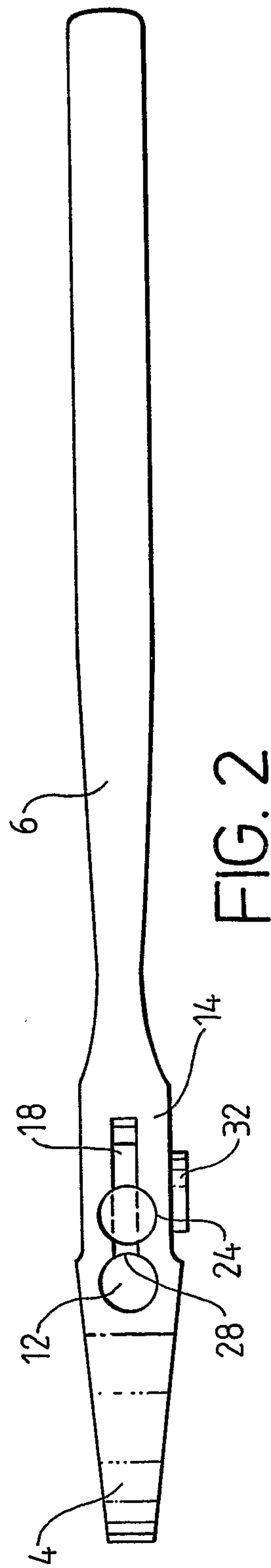
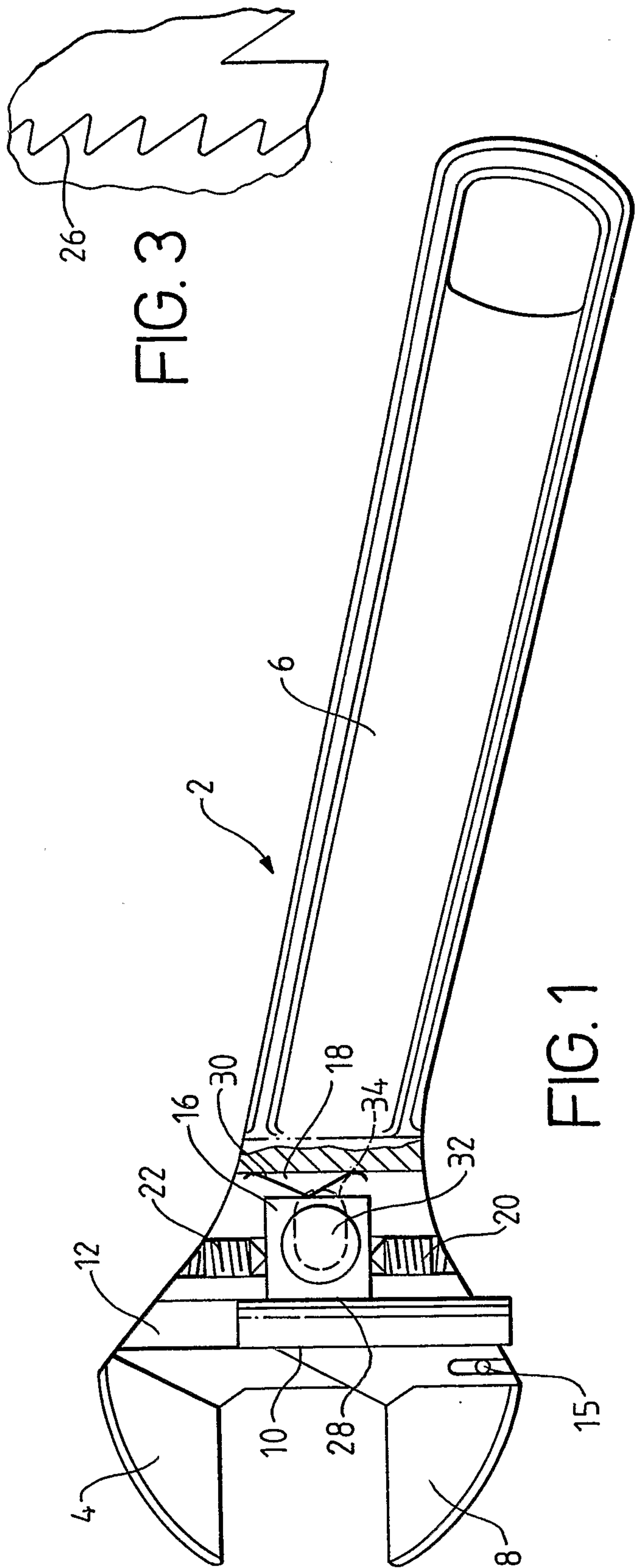

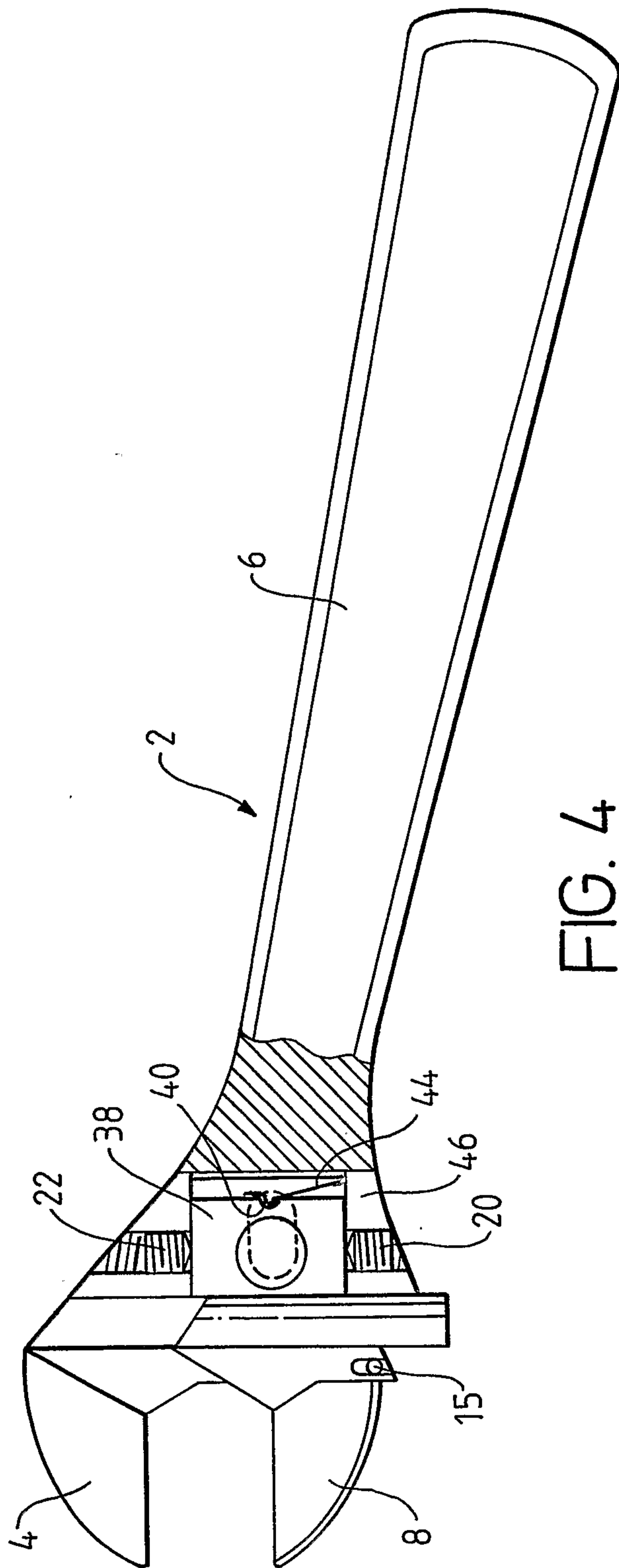

FIG. 4

