



Europäisches Patentamt
European Patent Office
Office européen des brevets



(11) **EP 1 219 909 B1**

(12) **EUROPEAN PATENT SPECIFICATION**

(45) Date of publication and mention
of the grant of the patent:
21.12.2005 Bulletin 2005/51

(51) Int Cl.7: **F25D 23/12, H05B 3/12**

(21) Application number: **01125519.7**

(22) Date of filing: **25.10.2001**

(54) **Refrigeration apparatus with butter-holding container**

Kältegerät mit Butterbehälter

Appareil frigorifique avec récipient pour beurre

(84) Designated Contracting States:
**AT BE CH CY DE DK ES FI FR GB GR IE IT LI LU
MC NL PT SE TR**

(30) Priority: **28.12.2000 IT PN000077**

(43) Date of publication of application:
03.07.2002 Bulletin 2002/27

(73) Proprietor: **ELECTROLUX HOME PRODUCTS
ITALY S.p.A.
33080 Porcia (Pordenone) (IT)**

(72) Inventors:
• **Sist, Santo
33080 Porcia (PN) (IT)**

• **Paroni, Luigi
33033 Codroipo (UD) (IT)**

(74) Representative: **Giugni, Valter et al
PROPRIA S.r.l.,
Via Mazzini 13
33170 Pordenone (IT)**

(56) References cited:
**US-A- 2 594 023 US-A- 2 953 357
US-A- 4 352 008 US-A- 5 839 507
US-A- 6 054 692**

• **PATENT ABSTRACTS OF JAPAN vol. 015, no.
416 (M-1172), 23 October 1991 (1991-10-23) & JP
03 175252 A (MATSUSHITA REFRIG CO LTD), 30
July 1991 (1991-07-30)**

EP 1 219 909 B1

Note: Within nine months from the publication of the mention of the grant of the European patent, any person may give notice to the European Patent Office of opposition to the European patent granted. Notice of opposition shall be filed in a written reasoned statement. It shall not be deemed to have been filed until the opposition fee has been paid. (Art. 99(1) European Patent Convention).

Description

[0001] The present invention refers to an improved type of refrigeration apparatus, which is provided with at least a removable container adapted to hold food items that must be slightly heated up immediately before use, such as in particular butter.

[0002] For reasons of greater simplicity, this description will merely cover a refrigeration apparatus provided with a single food storage compartment. However, it must be appreciated that the present invention may be freely extended to also cover other types of refrigeration or freezing apparatuses.

[0003] Largely known in the art are refrigeration apparatuses that are provided with removable containers adapted to store butter and heat it up so as to make it easier for it to be conveniently spread.

[0004] Such a refrigerator is disclosed in JP03175252.

[0005] Furthermore, the patent publication US 5,839,507 discloses a refrigeration apparatus that is provided with a removable container, which is arranged on a shelf of the door liner of said apparatus, and a cavity provided in the ceiling of the storage compartment in such a manner as to enable said container, the top portion of which is provided with an aperture, to be located exactly under said cavity when the door of the apparatus is closed. Such a cavity accommodates the lamp used to illuminate the storage compartment of the refrigeration apparatus. This lamp is switched on, ie. energized in a selective manner, in particular an intermittent manner, so that, when the door of the refrigeration apparatus is closed, said lamp is anyway able to illuminate and, as a result, slightly heat up the butter held in the container therebelow through the afore cited aperture.

[0006] While this solution appears to be rather effective in attaining the main purpose thereof, consisting in allowing the butter to be selectively and slightly heated up even when it is being stored inside the closed storage compartment of the refrigeration apparatus, it however still has a number of drawbacks that practically prevent it from being able to be used in an altogether advantageous manner. These drawbacks can be summarized as follows:

1) The energization, albeit intermittent, of the lamp when the door of the refrigeration apparatus is closed, ie. when the latter is not being used, causes the energy usage of the same apparatus to increase; furthermore, the heating effect that thereby unavoidably takes place inside the cold storage compartment as a whole, requires to be compensated by a correspondingly longer running time of the refrigerating unit, ie. the compressor, thereby bring about a further undesirable increase in the energy usage of the apparatus.

2) Owing to the lamp actually illuminating and, as a

result, heating up the entire container, a uniform temperature is generated in the container itself all around the piece of butter held therein, which is therefore heated up by all of the exposed surfaces of said container; this fact is generally known to practically cause the organoleptic and hygienic properties of the butter to undergo a quick decay, and ultimately sets serious limits to the actual storage duration or preservability thereof. One of the most obvious consequences of such a fact is also that, if the butter in the container is used just to a reduced extent, the butter itself nevertheless grows rancid quite quickly and must therefore be thrown away.

3) A third drawback derives directly from the far greater complexity and, as a result, cost of the circuits and devices needed to such a purpose, such as in particular the additional thermostat switch and the circuits required to control the temperature and, therefore, the illumination of the container.

4) A fourth major drawback derives from the fact that two different functions are actually activated by using a single and same device; in other words, both the illumination function and the butter-heating function are solely based on the same lamp. Such a solution, albeit quite cost-effective from a strictly manufacturing-related point of view, has however the disadvantage of subordinating a function that is given a certain priority, ie. heating up the butter, to a function that is on the contrary considered generally as a secondary one, ie. the internal lighting of the storage compartment. In practice, if the lamp breaks or burns off, ie. an event that cannot be considered as being inherently so serious, instead of providing for it to be replaced without any particular urgency, as this usually occurs in most cases, the need arises here for it to be replaced immediately, otherwise the butter-heating function would be practically lost in the meantime.

[0007] It would therefore be desirable, and is actually a major purpose of the present invention, to provide a refrigeration apparatus, preferably a household-type one, which is provided with at least a storage compartment adapted to solely heat up and, therefore, soften the upper layers of the pat of butter, is further capable of doing away with the afore described drawbacks, and is finally capable of being manufactured in a more economical manner, ie. at lower costs, as well as operating in a simple and reliable manner.

[0008] According to the invention this object is achieved by a refrigerator as defined in claim 1.

[0009] This aim is reached according to the present invention in a particular type of refrigeration apparatus provided with a butter-heating compartment, or container, which is described below by way of non-limiting ex-

ample with reference to the accompanying drawings, in which:

- Figure 1 is a perspective view of a food storage compartment with a type of butter-heating container according to the present invention;
- Figure 2 is a perspective view of the sole butter-heating container illustrated in Figure 1;
- Figure 3 is an exploded view of the major component parts of the butter-heating container shown in Figure 2:
- Figure 4 is a median vertical plane sectional view, according to the section A - A, of one of the component parts illustrated in Figure 3;
- Figure 5 is a view of a portion of said butter-heating container, as seen according to the view "D" of Figure 3.

[0010] With reference to the Figures, a refrigeration apparatus according to the present invention comprises at least an inner food storage compartment 1, in which there is arranged a container 2 for storing and selectively heating up a pat of butter 3 held therein.

[0011] This container 2 is mainly formed by: a lower body 4, an upper body 5, an irradiation screen 10 and a support tray 9.

[0012] This support tray 9 comprises a bottom plate 18 adapted to be inserted between appropriate ribs 8 provided internally on the lower body 4, and a vertical wall 7 which is applied on to the front edge of said bottom plate 18 and is so positioned and sized as to at the same time act as the closing element of the container and the seizing element for pulling out/pushing in said bottom plate 18 of the same container.

[0013] On the downward facing side of said upper body 5 there is applied a metal surface 10, which is preferably a highly conductive one and, therefore, ideally made of such a material as aluminium.

[0014] As illustrated in the Figures, this metal surface 10 is formed in the shape of roughly a barrel; in other words, it is constituted by two mutually opposing vertical walls 11 and 12, which are joined to each other by an upper curved surface 13 delimiting the central portion of said upper body 5 at the bottom thereof.

[0015] Above this curved surface 13, in contact therewith, there is positioned a PTC device 33, preferably of a flat construction.

[0016] The reason why such a PTC device is actually used instead of a traditional resistive element will be explained further on in this description.

[0017] In view of promoting the contact between the PTC device and said upper curved surface 13, the latter is so shaped, in the central portion thereof, so as to feature a downward protruding camber-like bulge 14 that

forms, on the upper side of said curved surface 13, a niche 15 so sized as to be capable of at least partially accommodating said PTC element, as this is shown in a simplified manner in Figure 4.

[0018] In this way the assurance is given, as this has been widely demonstrated by exhaustive experiments and test runs in the laboratory, that the heat issued by said PTC element is almost entirely transferred by conduction to said niche 15 which, by quickly heating up to approximately 140°C, is then capable of irradiating such a heat in a direction that is of course orthogonal to the surface thereof and, therefore, downwards and, as a result, exactly onto the top zone 16 of the pat of butter 3 arranged therebelow.

[0019] Those skilled in the art may object that the action of said PTC device might well extend to also heat up, albeit to a lesser extent, said vertical walls 11 and 12, so that these can radiate heat towards the side portions of the pat of butter 3, thereby partly nullifying the actual purpose and the advantages of the present invention. It has however been ascertained that, if said PTC device is well inserted in said niche 15, which should therefore be adequately deep, only a negligible part of the heat generated by the PTC device will be transferred to said side walls 11 and 12, while most of the generated heat is actually transferred to said niche and, from the latter, irradiated downwards.

[0020] It has also been observed that, in view of achieving a more intensive radiation from above and a far less intensive radiation on the sides, it proves adequate for the radiation to be as short as possible, in such a manner as to perform a radiation transient that privileges to a still greater extent the radiation from above, ie. downwards rather than sidewise. However, in order to be able to transmit the thermal energy required to soften the upper layer of the pat of butter, the need arises, given the quite short period of time that is available to such a purpose (in view of preventing that also the air is heated up thereby), for the power input to said PTC device to be very high initially, so as to enable it to absorb and irradiate as much energy as possible in as short a period of time as possible; furthermore said power should be significantly greater than the power output that can be ensured by traditional butter-heating devices, such as for example the one described in the afore cited patent publication.

[0021] These reasons actually explain why on the one hand the use of a PTC device is considered the preferred option and, on the other hand, why said PTC device is required to ensure an elevated rated power output, of at least 200 W, as determined experimentally.

[0022] However, since such a PTC device must operate for a time as strictly necessary for the upper layers of the pat of butter to soften, and shall then be de-energized immediately thereupon, since also the other portions of the butter would otherwise undergo heating, it is highly preferable that such a de-energization of the PTC device is carried out automatically by appropriate

electric timer circuits, wherein such circuits must most obviously be activated by the same energization command sent to said PTC device, most advantageously by an appropriate switch 17 situated outside the container 2.

[0023] It will be appreciated that other embodiments of the present invention are possible, as well. So, for example, it may also prove suitable, under certain points of view, for a PTC device to be still used as a heat-radiation source arranged in this case not above, but rather under the ceiling of said metal surface 10, in such a manner as to enable the latter to also act as a reflector to reflect part of the issued radiation and directs it again downwards.

[0024] Such a solution would certainly have the advantage of a greater thermal efficiency, but could give rise to some problem as far as the safety of the container as a whole is concerned.

[0025] Furthermore, said tray 9 must be as inert as possible to the effects of the radiations that can heat it up under the risk, therefore, that the tray itself may become capable of heating by conduction the pat of butter from the bottom upwards. In view of avoiding such a risk, said tray 9 is advantageously made of a thermally insulating, heat resistant material, preferably a thermoplastic material containing polycarbonates.

Claims

1. Refrigerator or freezer apparatus, in particular of the type for use in the home, comprising:
 - at least a food storage compartment (1) provided with a container (2) adapted to hold and preserve a specific food item, particularly butter, in which said container is provided with appropriate means adapted to let said specific food item undergo a heat treatment, consisting substantially of an infrared radiation that hits said specific food above,

characterized in that said means, providing said heat treatment, comprise a PTC device (33).
2. Refrigeration apparatus according to claim 1, **characterized in that** a metal surface (10) is arranged at least on the ceiling of said container, and that said PTC device (33) is positioned under said thermally conductive metal surface, so that the latter acts as a reflector to reflect said infrared radiation.
3. Refrigeration apparatus according to claim 1, **characterized in that** a thermally conductive metal surface (10) is arranged at least on the ceiling of said container, and that said heat-radiation source is positioned above said thermally conductive metal surface in contact therewith.

4. Refrigeration apparatus according to claim 3, **characterized in that** said thermally conductive metal surface is provided, in a substantially central portion thereof, with a downward facing camber-like swelling (14), and that this camber-like swelling creates, on the upper side of said metal surface, a niche (15) in which said PTC device (33) is accommodated at least partially.

Patentansprüche

1. Kühl- oder Gefriergerät, insbesondere vom Typ für die Verwendung im Haushalt, welches umfasst:
 - mindestens ein Fach (1) für die Lagerung von Nahrungsmitteln, welches mit einem Behälter (2) ausgestattet ist, der so ausgelegt ist, dass in ihm ein spezieller Nahrungsmittelartikel, insbesondere Butter, aufbewahrt und vor Verderb geschützt wird, wobei der genannte Behälter mit geeigneten Mitteln ausgestattet ist, welche so ausgelegt sind, dass der genannte Nahrungsmittelartikel einer thermischen Behandlung unterzogen wird, welche im Wesentlichen aus einer Infrarotstrahlung besteht, die von oben auf den genannten Nahrungsmittelartikel auftrifft, **dadurch gekennzeichnet, dass** die genannten Mittel, welche die genannte thermische Behandlung bewirken, eine PTC-vorrichtung (33) umfassen.
2. Kühlgerät gemäß Anspruch 1, **dadurch gekennzeichnet, dass** eine Metallfläche (10) zumindest an der Oberseite des genannten Behälters angeordnet ist und dass die genannte PTC-Vorrichtung (33) unterhalb der genannten thermisch leitenden Metallfläche angeordnet ist, so dass die Letztere als Reflektor wirkt, um die genannte Infrarotstrahlung zu reflektieren.
3. Kühlgerät gemäß Anspruch 1, **dadurch gekennzeichnet, dass** eine thermisch leitende Metallfläche (10) zumindest an der Oberseite des genannten Behälters angeordnet ist und dass die genannte Wärmestrahlungsquelle sich oberhalb der genannten thermisch leitenden Metallfläche und sich mit dieser in Kontakt befindet.
4. Kühlgerät gemäß Anspruch 3, **dadurch gekennzeichnet, dass** die genannte thermisch leitende Metallfläche im Wesentlichen in ihrem mittleren Bereich eine nach unten gerichtete bogenförmige Ausbauchung (14) aufweist und dass diese bogenförmige Ausbauchung auf der oberen Seite der genannten Metallfläche eine Nische (15) ausbildet, in welcher die genannte PTC-vorrichtung (33) zumindest teilweise untergebracht ist.

Revendications

1. Réfrigérateur ou appareil de congélation, en particulier du type utilisé pour la maison, comprenant :
- 5
- au moins un compartiment de stockage d'aliments (1) muni d'un récipient (2) adapté pour contenir et conserver un article alimentaire donné, en particulier du beurre, dans lequel ledit récipient est muni de moyens appropriés adaptés pour faire subir audit article alimentaire donné un traitement thermique consistant pour l'essentiel en un rayonnement infrarouge qui frappe ledit article alimentaire donné par le dessus, **caractérisé en ce que** lesdits moyens délivrant ledit traitement thermique comprennent un dispositif à coefficient de température positif (33).
- 10
15
2. Appareil frigorifique selon la revendication 1, **caractérisé en ce qu'**une surface métallique (10) est placée au moins sur le plafond dudit récipient, et **en ce que** ledit dispositif à coefficient de température positif (33) est placé sous ladite surface métallique conductrice thermique, de sorte que cette dernière agit comme un réflecteur pour renvoyer ledit rayonnement infrarouge.
- 20
25
3. Appareil frigorifique selon la revendication 1, **caractérisé en ce qu'**une surface métallique conductrice thermique (10) est placée au moins sur le plafond dudit récipient, et **en ce que** ladite source de rayonnement thermique est placée au-dessus de ladite surface métallique conductrice thermique, en contact avec elle.
- 30
35
4. Appareil frigorifique selon la revendication 3, **caractérisé en ce que** ladite surface métallique conductrice thermique est munie, dans une partie sensiblement centrale, d'un renflement (14) de type cambrure tourné vers le bas, et **en ce que** ce renflement de type cambrure crée sur la face supérieure de ladite surface métallique une niche (15) dans laquelle ledit dispositif à coefficient de température positif (33) est logé au moins partiellement.
- 40
45

50

55

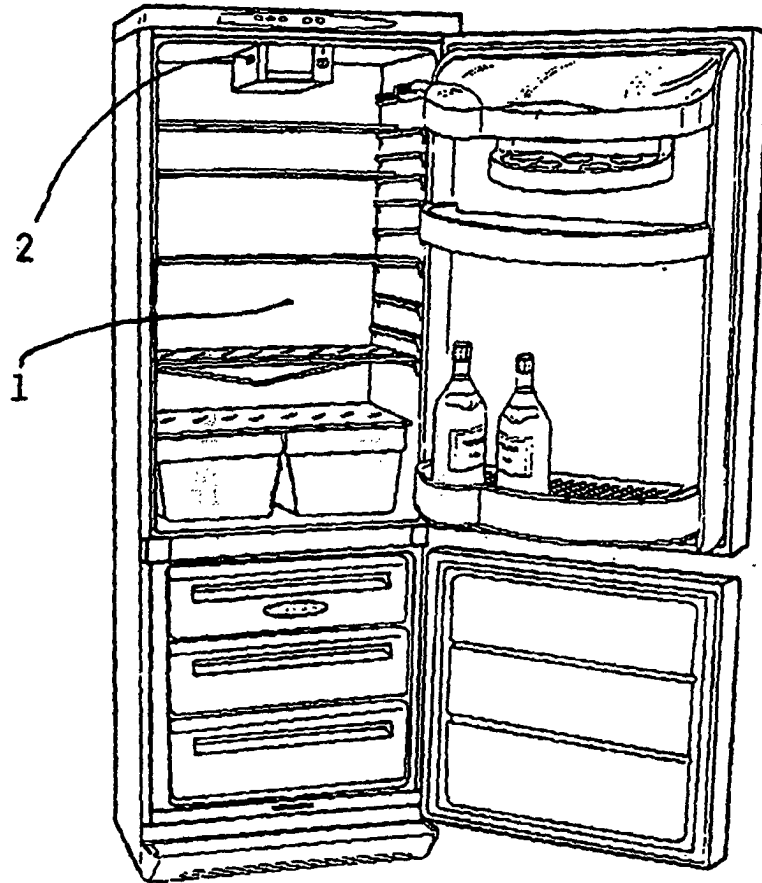

FIG. 1

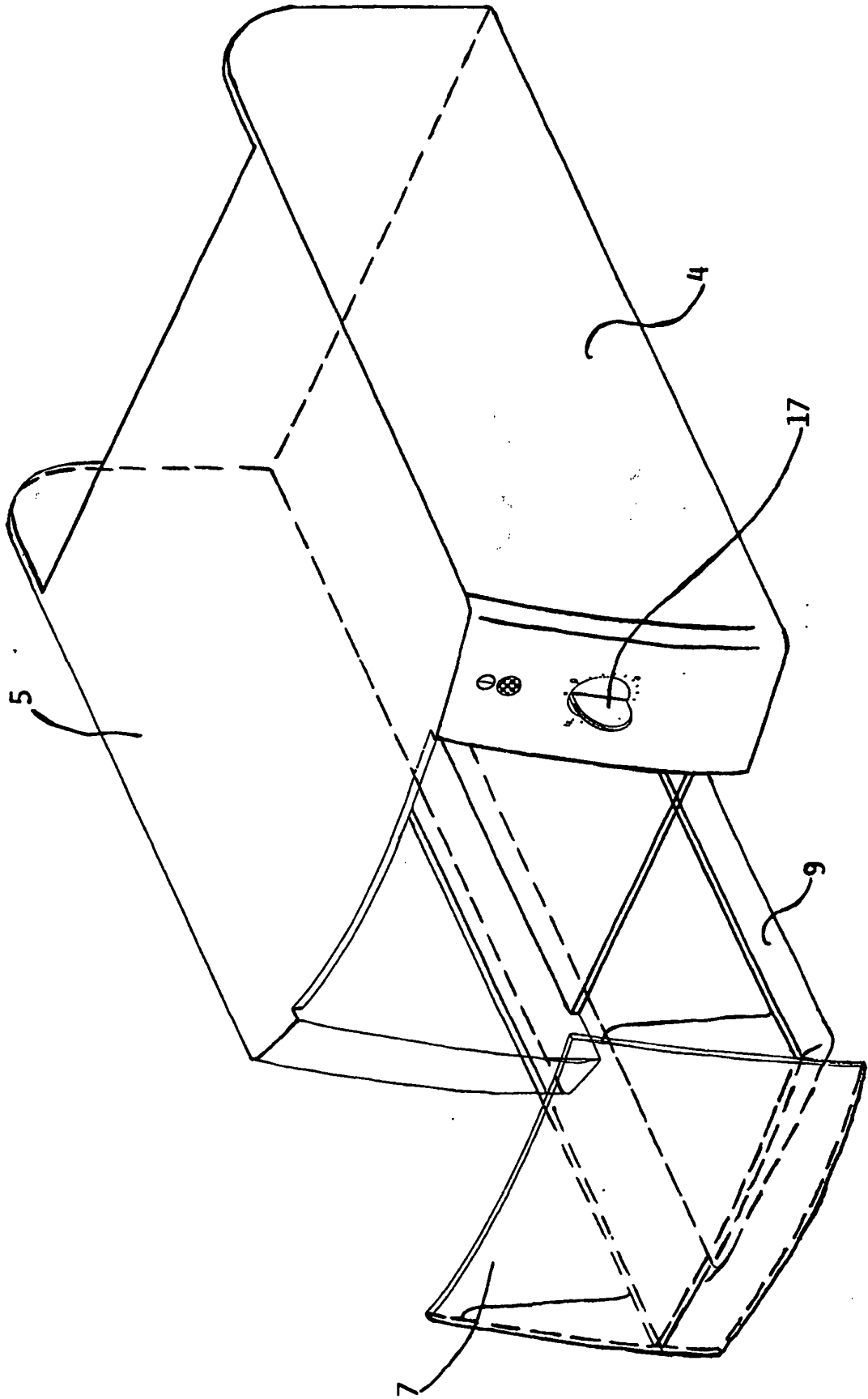

FIG. 2

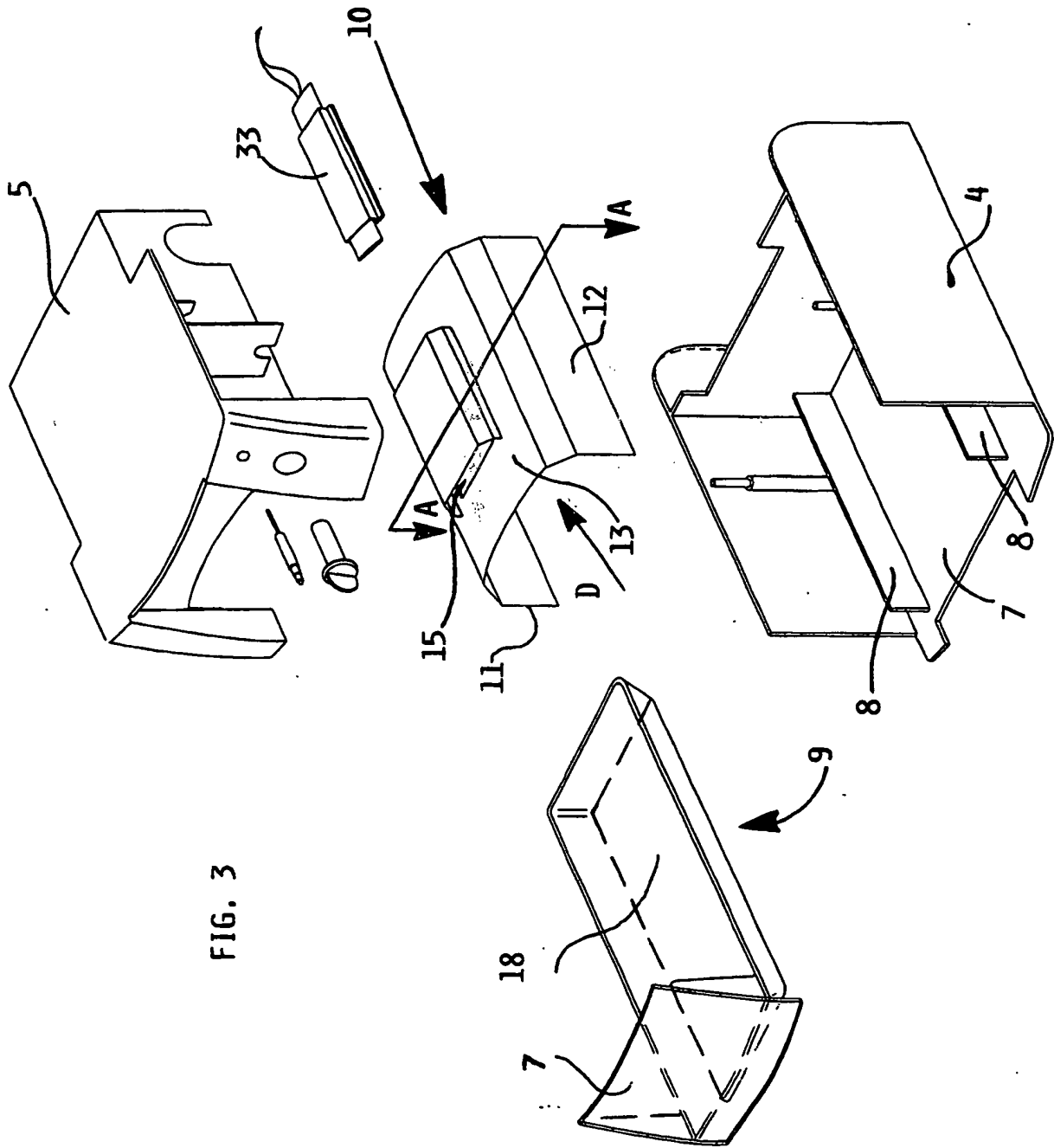

FIG. 3

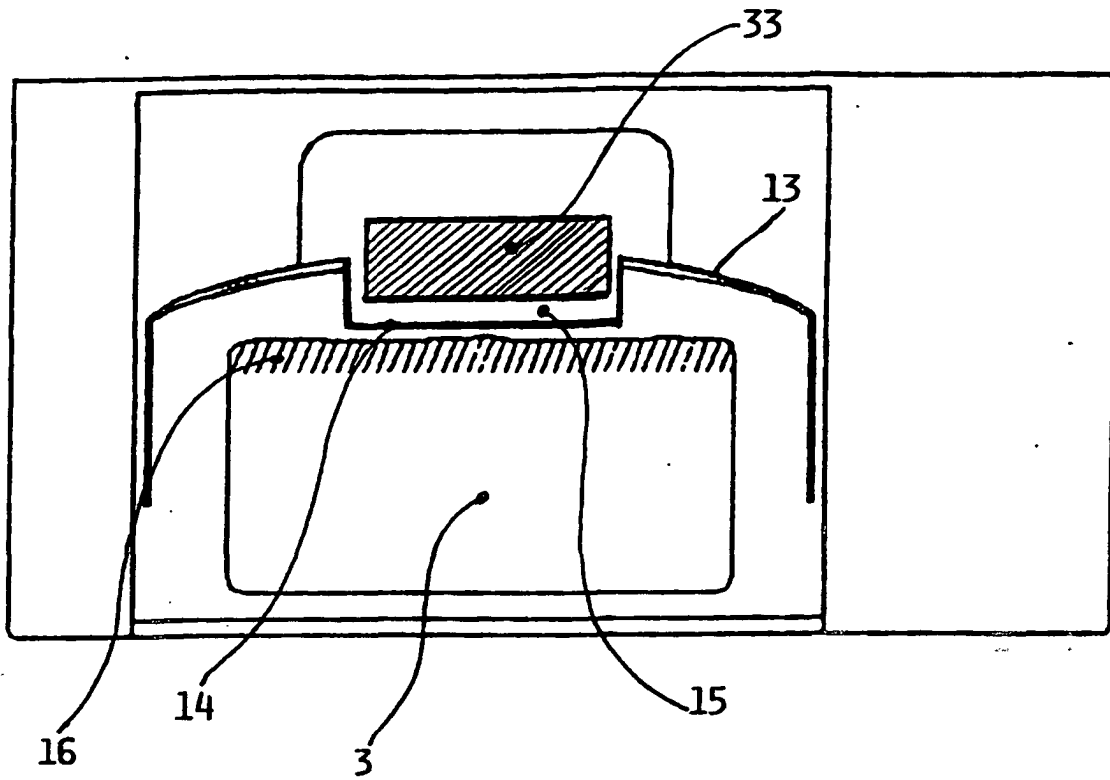

FIG. 4

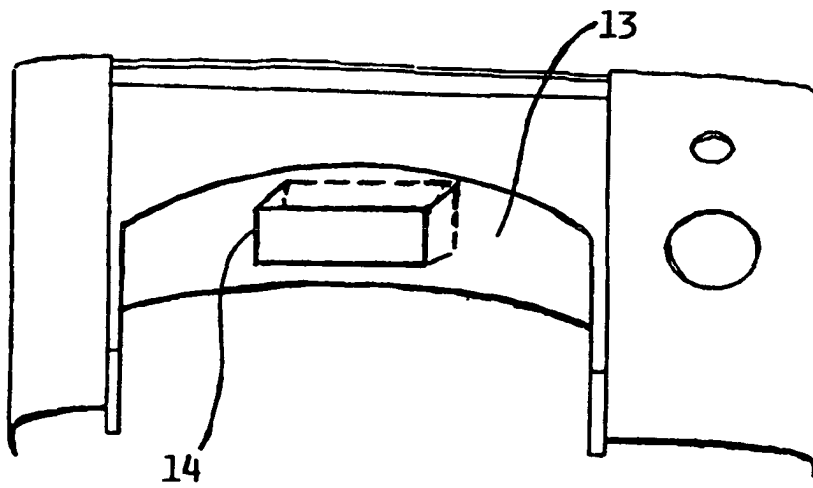

FIG. 5