

(21) Application No: 0620873.0
(22) Date of Filing: 20.10.2006

(71) Applicant(s):
Leo Siemann
Oasis, 20 Bridge Road, TORQUAY, Devon,
TQ2 5BA, United Kingdom

(72) Inventor(s):
Leo Siemann

(74) Agent and/or Address for Service:
Leo Siemann
Oasis, 20 Bridge Road, TORQUAY, Devon,
TQ2 5BA, United Kingdom

(51) INT CL:
A47C 7/00 (2006.01) **A47C 7/42** (2006.01)

(56) Documents Cited:
DE 019931126 A1 **DE 004202067 C1**
DE 003724615 A1 **US 5820220 A1**
US 5335971 A1 **US 20020121801 A1**

(58) Field of Search:
UK CL (Edition X) **A4L**
INT CL **A47C**
Other: **Online: EPODOC, WPI**

(54) Abstract Title: **Chair comprising a frame with a space for storing equipment**

(57) A chair comprises a frame 1, a support 2, a seat 4, a seat back 5 and detachable armrests 9 and footrests 16. Wheels 21 and a strap 13 are attached to the frame. The seat back can be folded onto the seat, the support allows the seat to be rotated and adjusted in height, and the frame comprises a space for storing equipment. The frame may comprise buffers 19 to support a shelf 20 beneath the seat. The chair may be made of wood, plastic or metal. The support may comprise a ball bearing (25, Fig. 8) to facilitate rotation of the seat and a pin 3 to secure the seat at various heights.

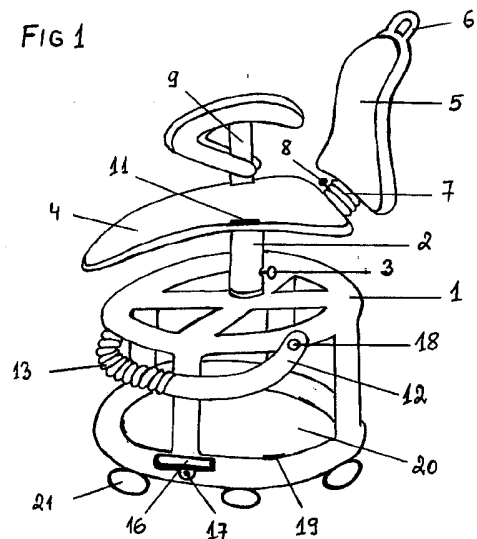

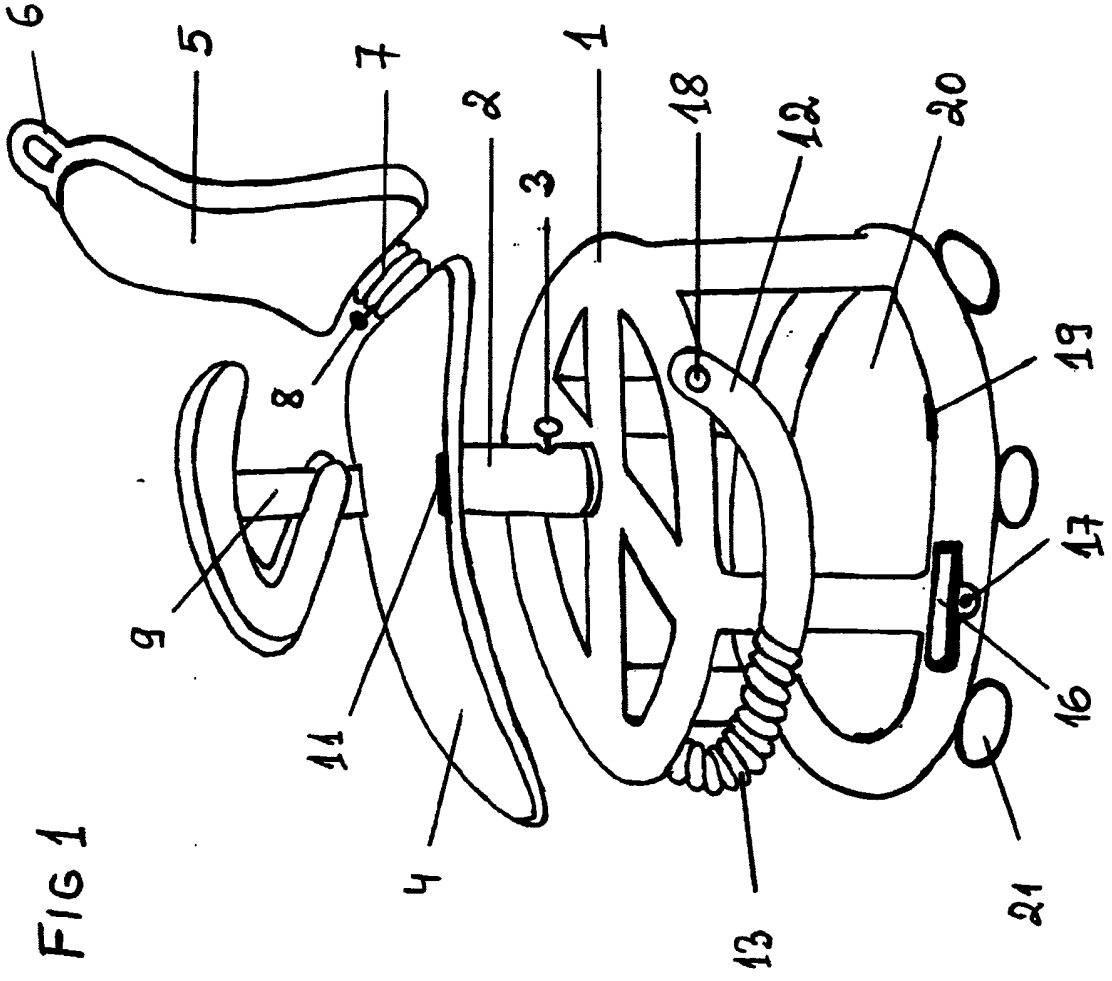

FIG 1

2/5

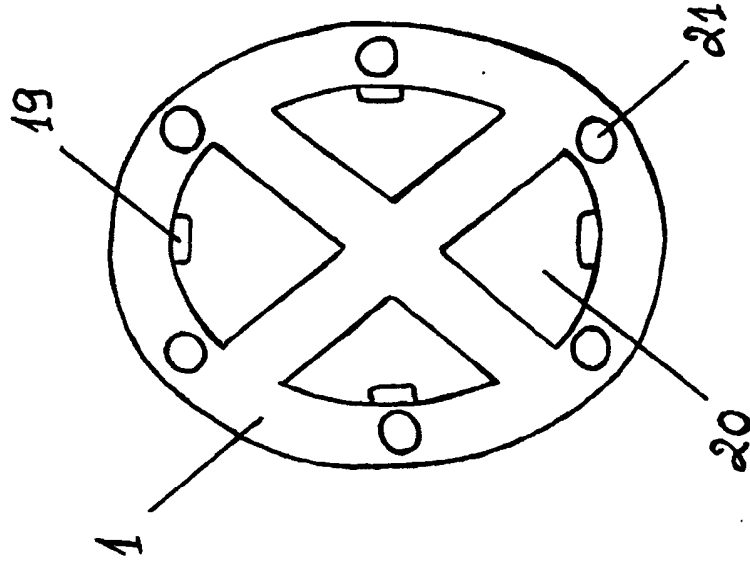

FIG 3

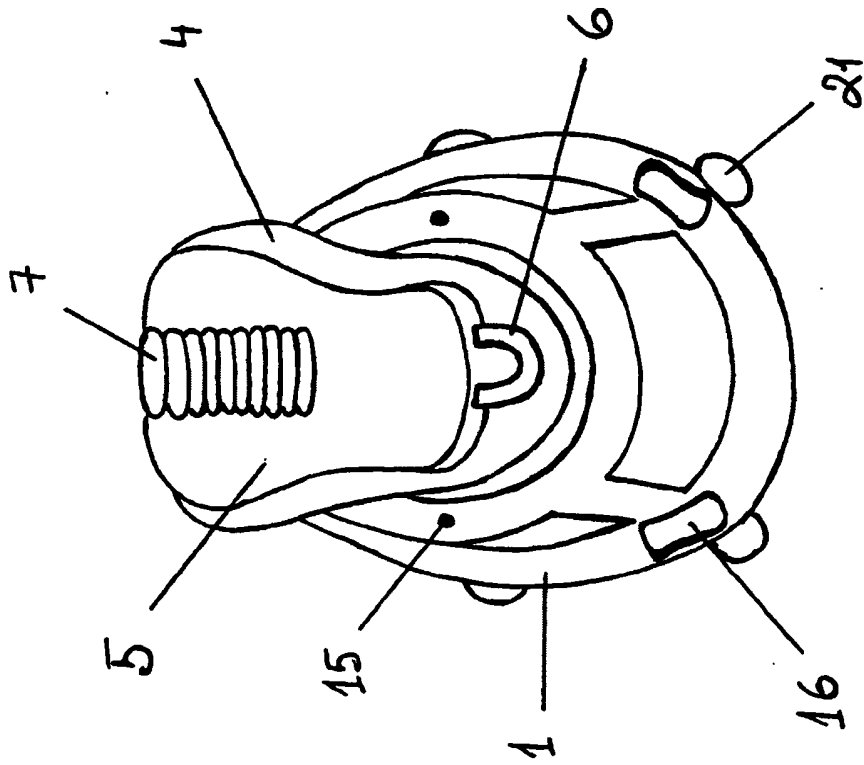

FIG 2

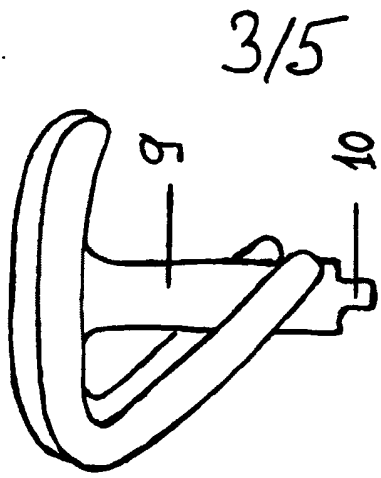
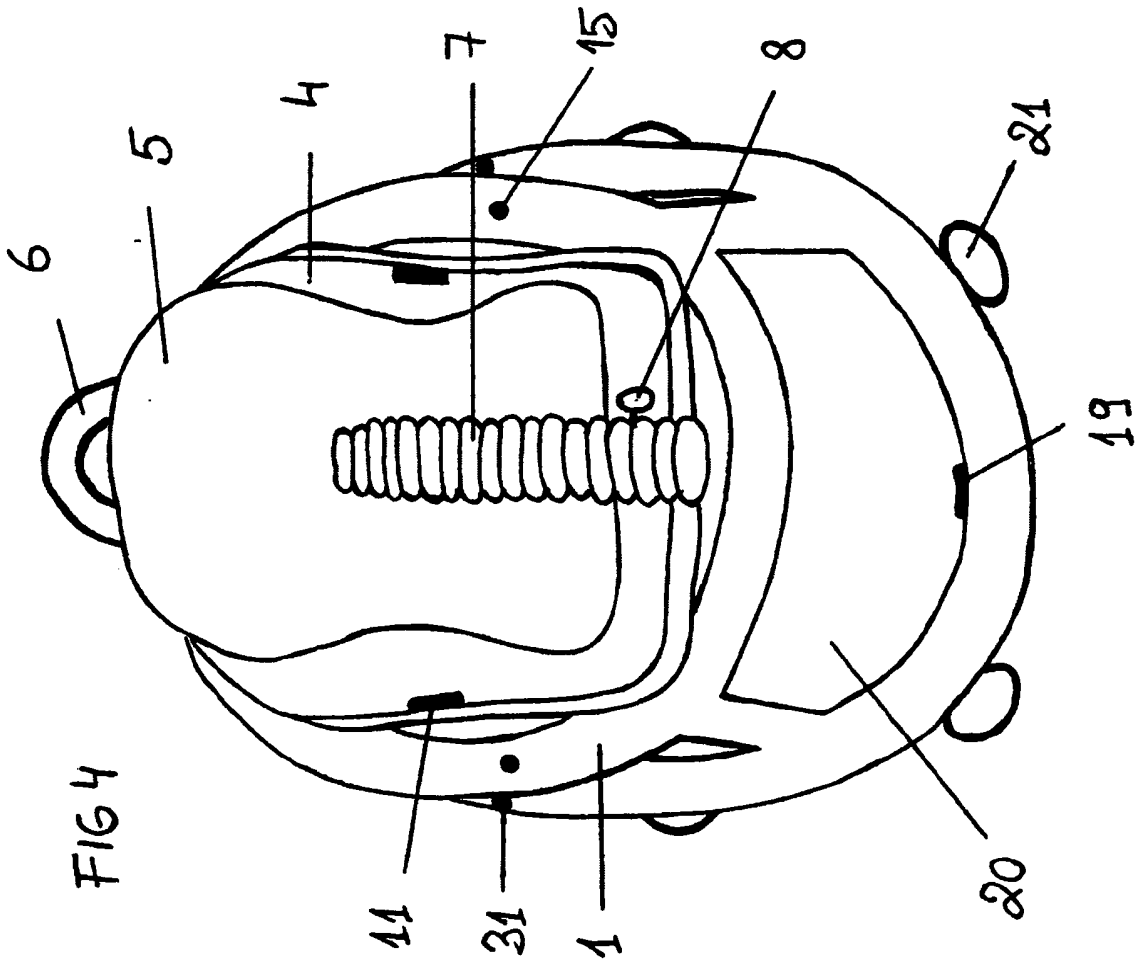

FIG 5

4/5

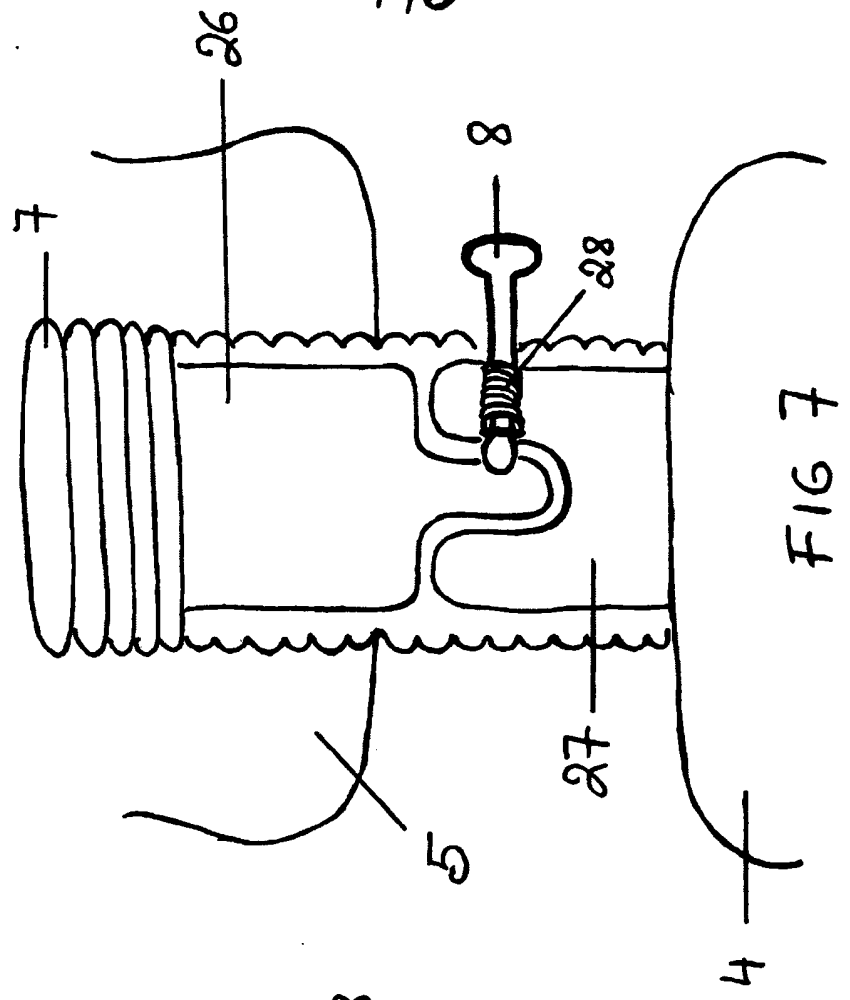
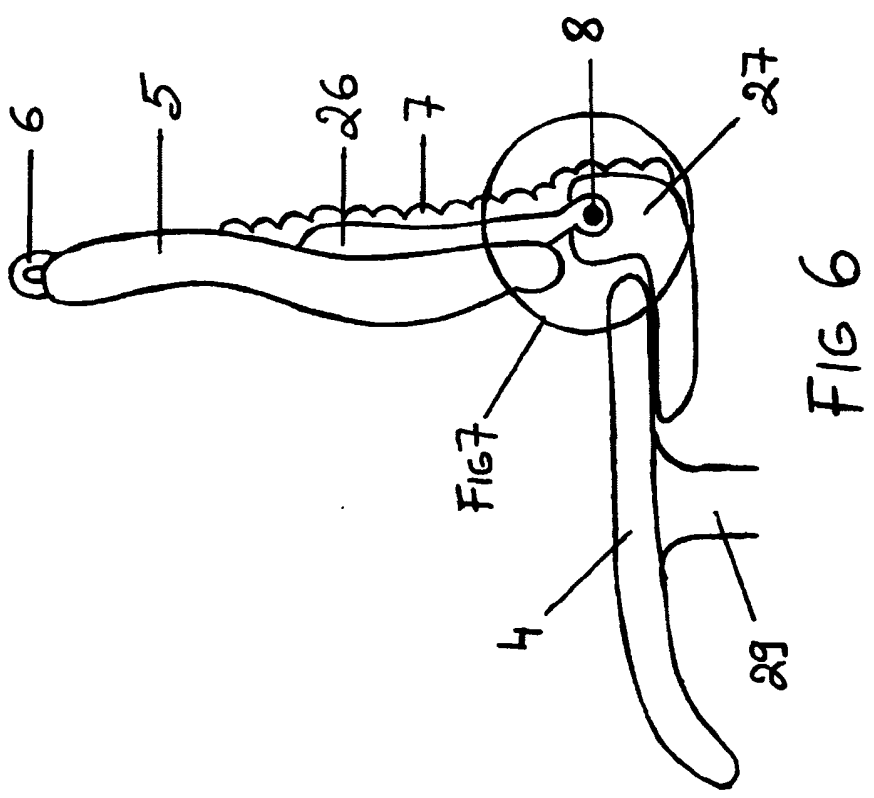

FIG 7

4

29

27

8

7

26

5

6

FIG 7

4

27

8

28

7

26

5

4

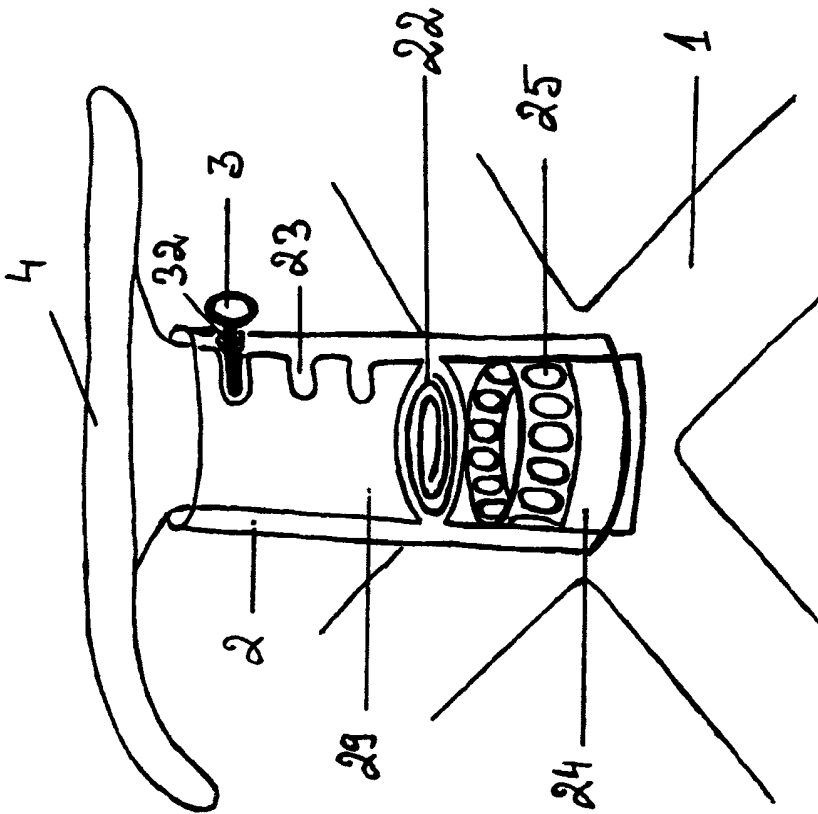
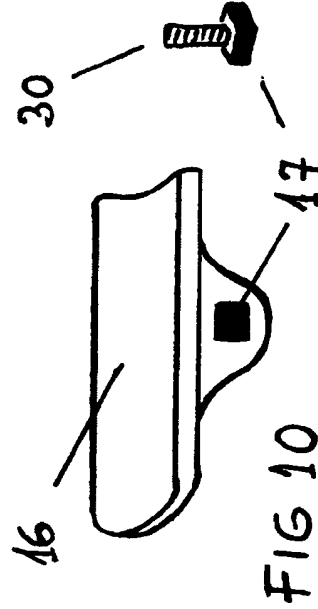
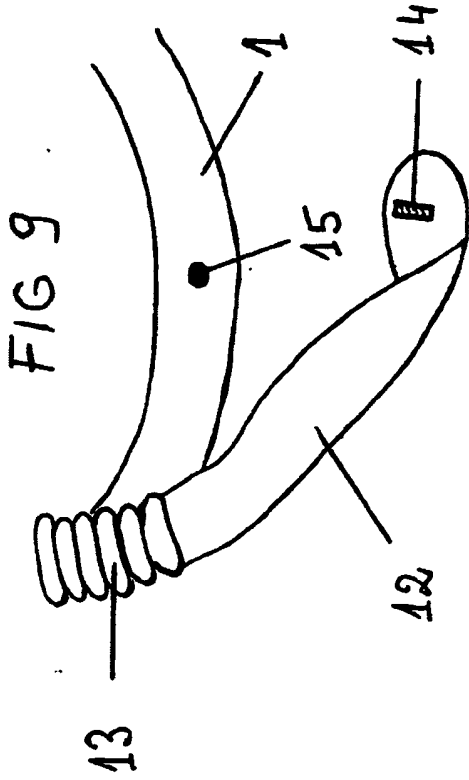

CHAIR FOR VARIOUS DEVICES OR EQUIPMENT

This invention relates to furniture, more specifically office type of furniture.

Hundreds of different chairs and office-chairs have been invented, which differ from their construction and design, but often taking up a lot of space and are uncomfortable to transport. Since many contemporary offices and people's apartments are often confined, in addition to comfort, saving in space and multi-functionality are becoming more and more important. Considering all these factors, this kind of invention can be handy in small offices, schools, shops, for disabled people or in industry where is important facilitating various devices or equipment nearby.

The main difference about this chair is the unique construction of the frame, which has space between its two levels under the seat, enable the chair to carry different kind of mechanical-, electronic- and digital devices or various equipment. It also has an adjustable, revolving seat, folding back, detachable armrests and footrests, shelf, and carrying strap. Three or more revolving wheels are fixed to the frame. The chair is compact, mobile and easy to transport. The idea of the multi-functional invention is economizing the space.

The removable shelf is preferably provided to support devices or equipment on the lower level of the frame. Footrests can come handy for a child or person who sits on the chair for a longer period of time. Carrying strap enables to lift the chair up and take it to upstairs, downstairs or somewhere else.

The technical nature of the invention is explained with the following figures:

FIG 1 shows general image of the chair

FIG 2 shows frontal view of the chair

FIG 3 shows the view from below

FIG 4 shows the view from behind

FIG 5 shows armrest

FIG 6 shows side view of the back of the chair mechanism

FIG 7 shows frontal view of the back of the chair mechanism

FIG 8 shows chair support mechanism

FIG 9 shows attaching the strap to the frame

FIG 10 shows footrest and the screw for attachment

Probably the closest analogue to the given model is my first invention called "Office-chair for vacuum cleaner". Application number: GB 0618716.5 filed on 22nd September 2006.

This particular chair could carry some essential devices for film and music industry for example or just be a good place for schoolbag or for a little cupboard. It also can be useful for various equipment in laboratories, offices or in any sort of industry. And no less important, it can become handy for disabled people in different reasons. So, the use of this type of chair can be really enormous.

Chair for various devices or equipment consists of a frame 1, a mechanical or hydraulic support attached to it 2, the seat of the chair 4 and the back of the chair 5. Three or more metal or plastic rotating wheels 21 and removable carrying strap 12 are attached to the frame. The seat 4 and the back 5 of the chair are connected to each other by a mechanism i.e. hinge, that allows to fold the back of the chair if necessary. A handle 6 has been attached to the back of the chair 5 to facilitate the adjusting of the back of the chair. The rotating of the chair is possible with a ball bearing 25, which is attached to the part exerting from the frame 24. There are holes 23 in the leg of the chair 29, to adjust to different heights with help of the pin 3 and spring 32. Between the leg of the chair 29 and the part exerting from the frame 24 there is a spring 22 to facilitate the shifting of the mechanism. The frontal part of the seat 4 can be tilted to ensure safety. The metal mechanism of the back of the chair i.e. hinge is covered with a plastic coating 7. For more stable adjusting of the pin 8 there is a spring 28 in the section where the hinge is connected to the seat 27, which is compressed if pulled. When the pin 8 has been pulled out of the back of the seat part of the hinge 26, the back of the seat 5 can be folded on the seat of the chair 4. The seat of the chair 4, back of the chair 5 and armrests 9 are covered with fabric, leather or similar material. Armrests are attached to the openings 11 on the edge of the seat 4 with the leg of the armrest 10. There are buffers 19 on the inside of the frame to support removable shelf 20 or device. The strap of the chair 12 that is made of strong fabric, plastic or metal wires can be equipped with leather or similar material handle 13 and attaches to corresponding holes 15 on the frame 1 with the metal screw 14. On the other side of the strap there is a button 18 to facilitate the action. The chair can be easily carried around holding from the strap. Two detachable footrests 16 are also attached to the frame 1 with screws 30, which are equipped with buttons 17 to facilitate the action. There are corresponding holes 31 in the frame for these screws.

CLAIMS

1. Chair for various devices or equipment, which consists of a frame, support, seat, back of a chair, armrests, footrests, three or more wheels attached to the frame and strap, which is different because the back of the chair can be folded on the seat, armrests and footrests are detachable, support enables to rotate and adjust the height of the chair and mechanical-, electronic- or digital devices or various equipment can be placed between the two levels of the frame of the chair.
2. Chair according to point 1, which is different because the frame of the chair has horizontal and vertical supports and buffers have been attached to the inner surface to support the shelf on the bottom of the chair.
3. Chair according to point 1, which is different because the frame of the chair, support, seat, back of the chair, armrests, footrests and wheels are made of wood.
4. Chair according to point 1, which is different because the frame of the chair, support, seat, back of the chair, armrests, footrests and wheels are made of plastic or similar material.
5. Chair according to point 1, which is different because the frame, support, seat, back of the chair, armrests, footrests and wheels are made of metal alloy.
6. Chair according to point 1, which is different because the seat, back of the chair and armrests are covered with different covering materials.
7. Chair according to point 1, which is different because there is a handle at the end of the back of the chair and the back of the chair is attached to the seat with a hinge, which allows the back of the chair to be folded on the seat.
8. Chair according to point 1, which is different because the support enables to rotate the chair with the help of the ball bearing and adjust the height of the chair with pin.
9. Chair according to point 1, which is different because removable strap is attached to the frame.
10. Chair according to point 1, which is different because the shape of the frame, seat and back can be changed to the round-, square-, triangle-, rectangle-, ellipse- or oval shape, but will essentially remain the same regarding to the construction.

Amendments to the claims have been filed as follows

1. Chair for various devices or equipment, which consists of a frame, support, seat, back of a chair, armrests, footrests, three or more wheels attached to the frame and strap, **which is different** because the frame of the chair has horizontal and vertical supports which are forming the space between its two levels under the seat.
2. Chair according to point 1, **which is different** because the frame of the chair, support, seat, back of the chair, armrests, footrests and wheels are made of metal alloy.
3. Chair according to point 1, **which is different** because the frame of the chair, support, seat, back of the chair, armrests, footrests and wheels are made of plastic or similar material.
4. Chair according to point 1, **which is different** because the frame of the chair, support, seat, back of the chair, armrests, footrests and wheels are made of wood.
5. Chair according to point 1, **which is different** because the seat, back of the chair and armrests are covered with different covering materials.
6. Chair according to point 1, **which is different** because removable strap is attached to the frame.
7. Chair according to point 1, **which is different** because the shape of the frame, seat and back of the chair can be changed to the round-, square-, triangle-, rectangle-, ellipse-, or oval shape, but will essentially remain the same regarding to the construction.



5

Application No: GB0620873.0

Examiner: Mr Nick Smith

Claims searched: 1-10

Date of search: 5 December 2007

Patents Act 1977: Search Report under Section 17

Documents considered to be relevant:

Category	Relevant to claims	Identity of document and passage or figure of particular relevance
Y	1-10	DE 4202067 C1 (GEBRÜDER) 18.12.93 (See in particular Figs. 1 & 3 and WPI Abstract Accession No. 1993-053959 [07])
Y	1-10	DE 19931126 A1 (MÜLLER) 18.05.00 (See in particular Fig. 1 and WPI Abstract Accession No. 2000-377636 [33])
Y	1-7, 9-10	US 2002/0121801 A1 (WHITESIDE) See in particular Fig. 1 and paragraphs [0018]-[0019]
Y	1-10	US 5820220 A1 (WU) See in particular Fig. 6
Y	1-6, 8-10	US 5335971 A1 (KELLEY) See in particular Fig. 2
Y	1-6, 8-10	DE 3724615 A1 (INABA) 02.02.89 (See in particular Fig. 1 and WPI Abstract Accession No. 1989-040104 [06])

Categories:

X	Document indicating lack of novelty or inventive step	A	Document indicating technological background and/or state of the art.
Y	Document indicating lack of inventive step if combined with one or more other documents of same category.	P	Document published on or after the declared priority date but before the filing date of this invention.
&	Member of the same patent family	E	Patent document published on or after, but with priority date earlier than, the filing date of this application.

Field of Search:

Search of GB, EP, WO & US patent documents classified in the following areas of the UKC^X:

A4L

Worldwide search of patent documents classified in the following areas of the IPC

A47C

The following online and other databases have been used in the preparation of this search report

EPODOC, WPI

International Classification:

6

Subclass	Subgroup	Valid From
A47C	0007/00	01/01/2006
A47C	0007/42	01/01/2006