



US 20240245089A1

(19) **United States**

(12) **Patent Application Publication**  
**KOIDE et al.**

(10) **Pub. No.: US 2024/0245089 A1**

(43) **Pub. Date: Jul. 25, 2024**

(54) **TOBACCO SHEET FOR  
NON-COMBUSTION-HEATING-TYPE  
FLAVOR INHALER,  
NON-COMBUSTION-HEATING-TYPE  
FLAVOR INHALER, AND  
NON-COMBUSTION-HEATING-TYPE  
FLAVOR INHALATION SYSTEM**

(71) Applicant: **Japan Tobacco Inc.**, Tokyo (JP)

(72) Inventors: **Akihiro KOIDE**, Tokyo (JP);  
**Kimitaka UCHII**, Tokyo (JP);  
**Takahiro MATSUDA**, Tokyo (JP);  
**Ayaka HASHIMOTO**, Tokyo (JP);  
**Kazuhiro NODA**, Tokyo (JP); **Yuta  
YANAI**, Tokyo (JP); **Hirotsugu  
WAKABAYASHI**, Tokyo (JP)

(73) Assignee: **Japan Tobacco Inc.**, Tokyo (JP)

(21) Appl. No.: **18/591,766**

(22) Filed: **Feb. 29, 2024**

**Related U.S. Application Data**

(63) Continuation of application No. PCT/JP2022/032765, filed on Aug. 31, 2022.

(30) **Foreign Application Priority Data**

Sep. 1, 2021 (WO) ..... PCT/JP2021/032156  
Sep. 1, 2021 (WO) ..... PCT/JP2021/032157  
Oct. 18, 2021 (JP) ..... 2021-170066

**Publication Classification**

(51) **Int. Cl.**  
*A24B 15/10* (2006.01)  
*A24B 15/32* (2006.01)  
*A24D 1/20* (2006.01)  
*A24F 40/20* (2006.01)  
(52) **U.S. Cl.**  
CPC ..... *A24B 15/10* (2013.01); *A24B 15/32*  
(2013.01); *A24D 1/20* (2020.01); *A24F 40/20*  
(2020.01)

(57) **ABSTRACT**

Provided is a tobacco sheet for a non-combustion-heating-type flavor inhaler, the tobacco sheet including a fibrous material.

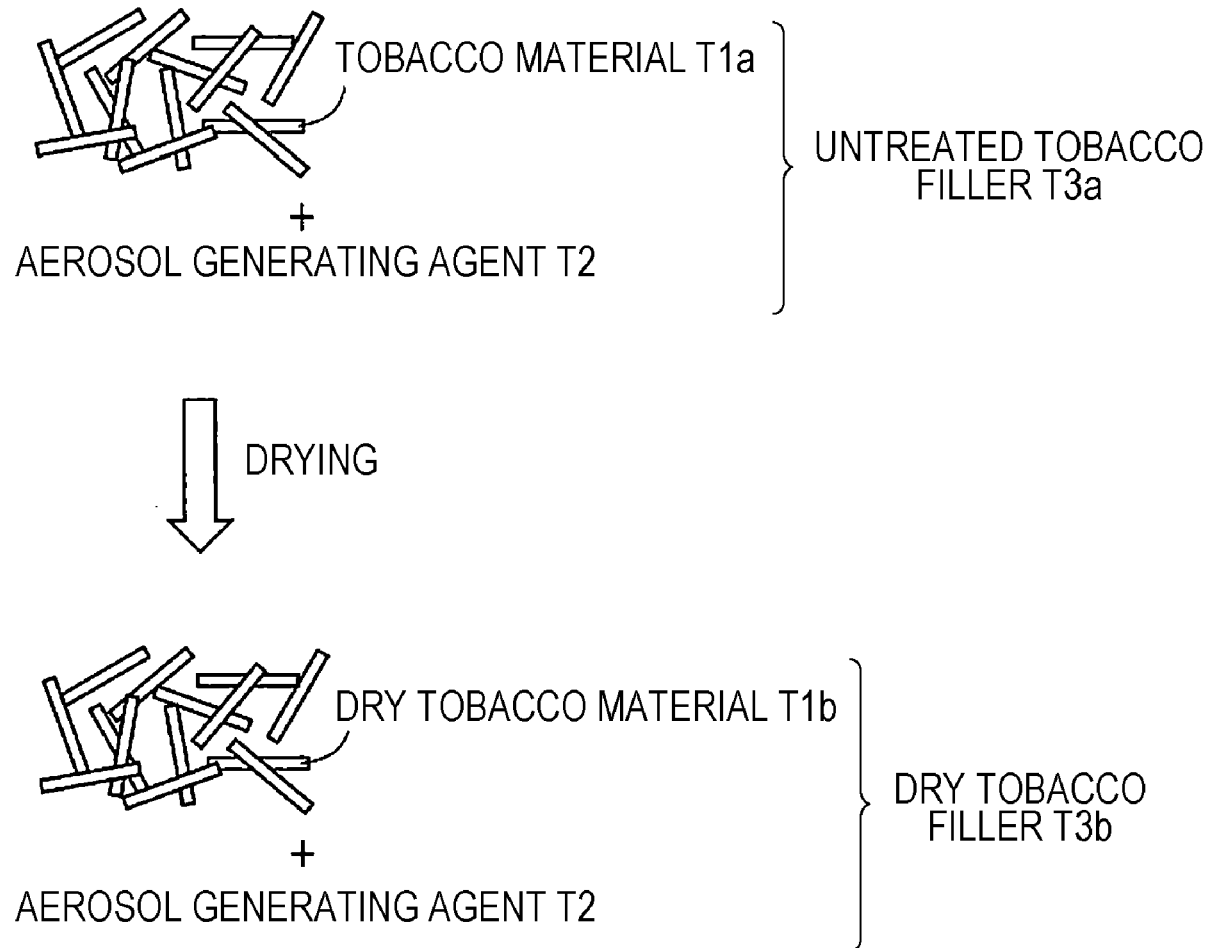

Fig. 1

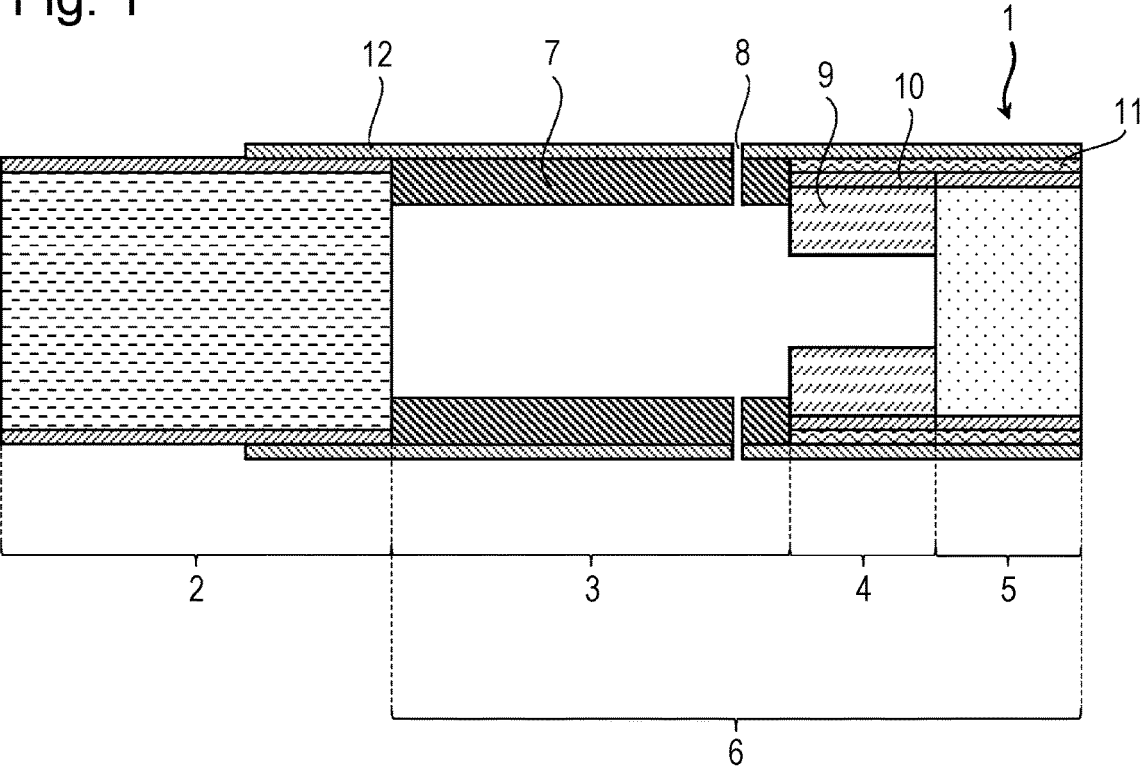

Fig. 2

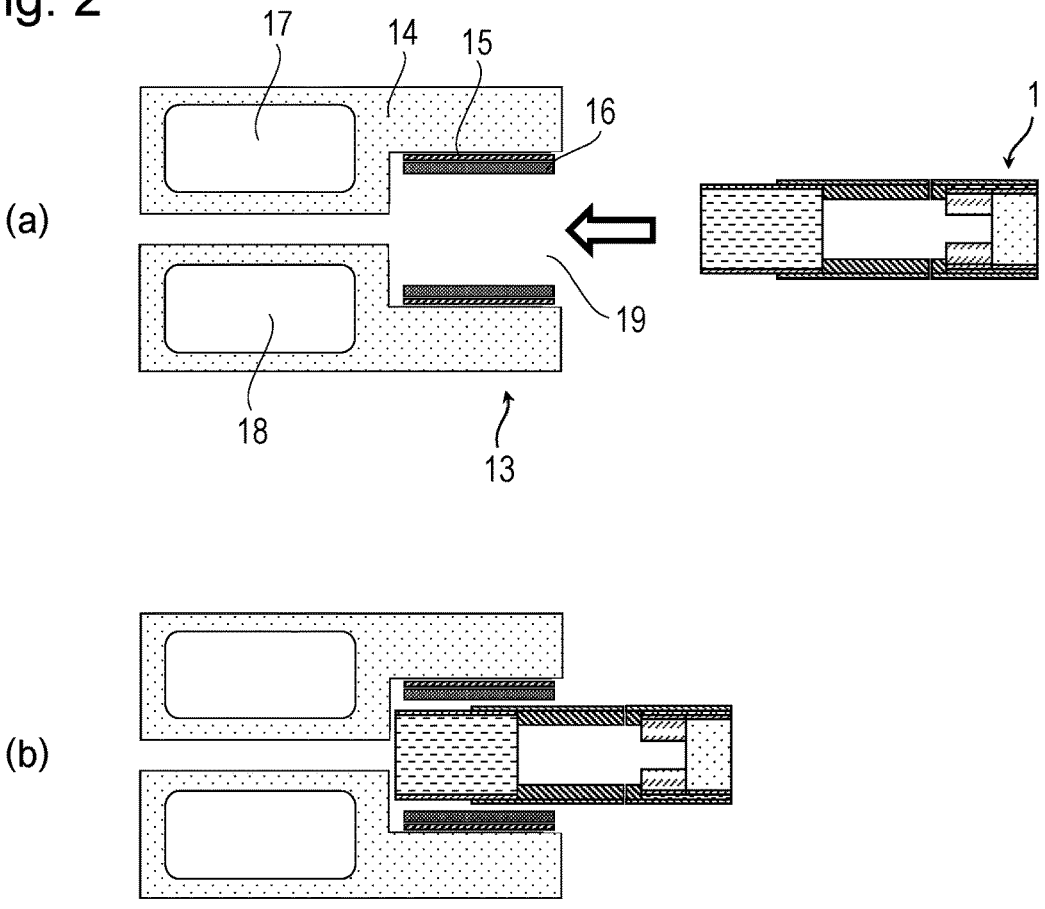

Fig. 3

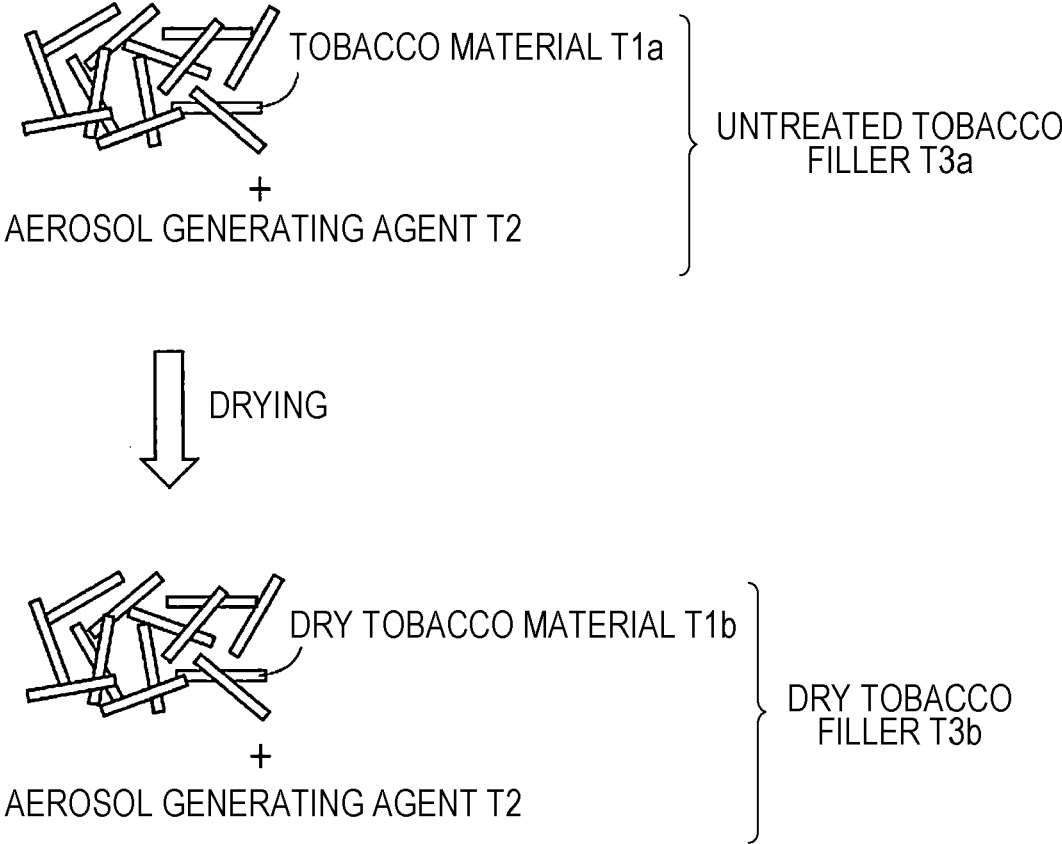

Fig. 4

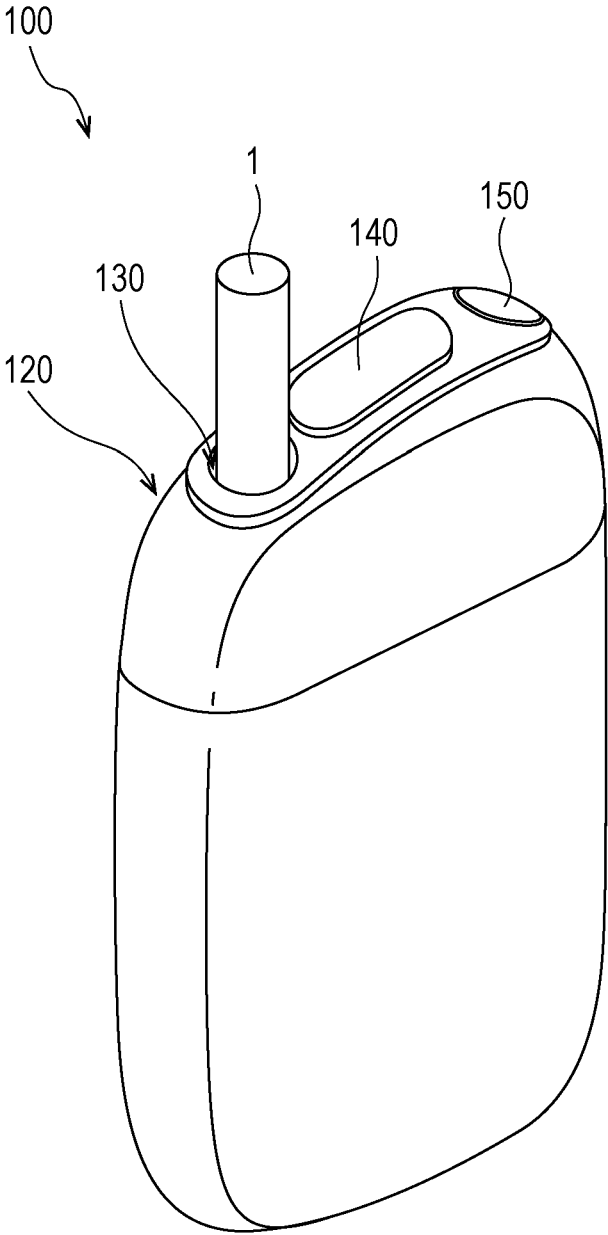

Fig. 5

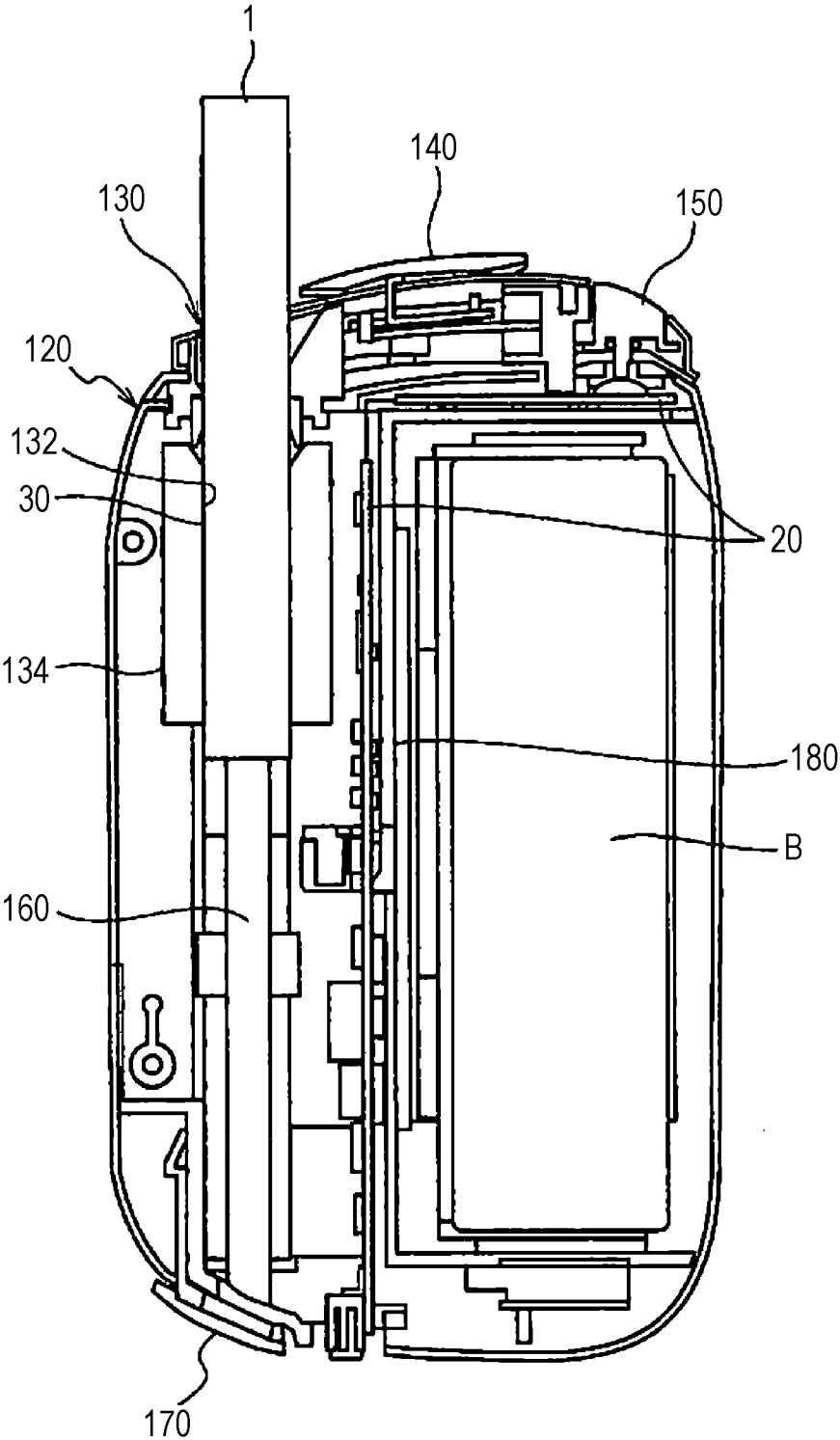

Fig. 6

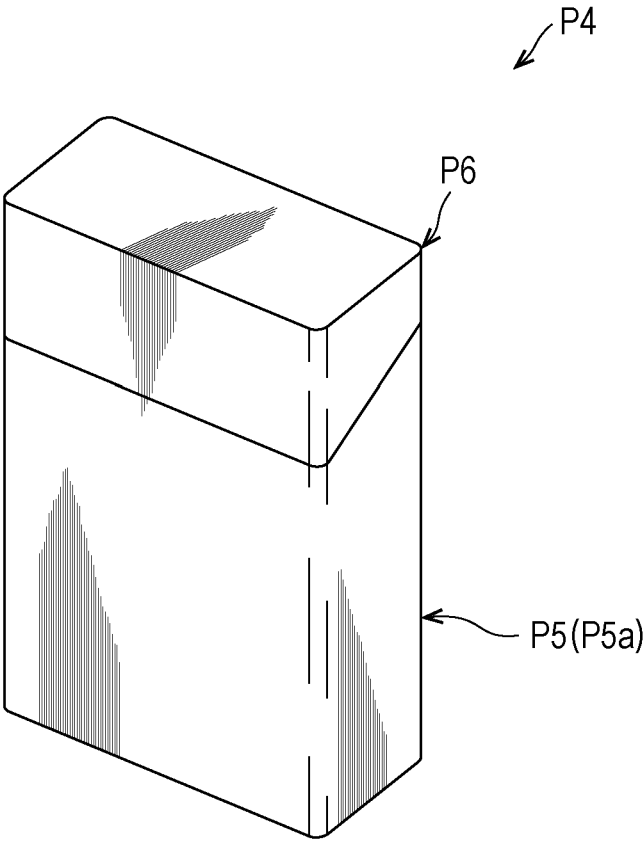

Fig. 7

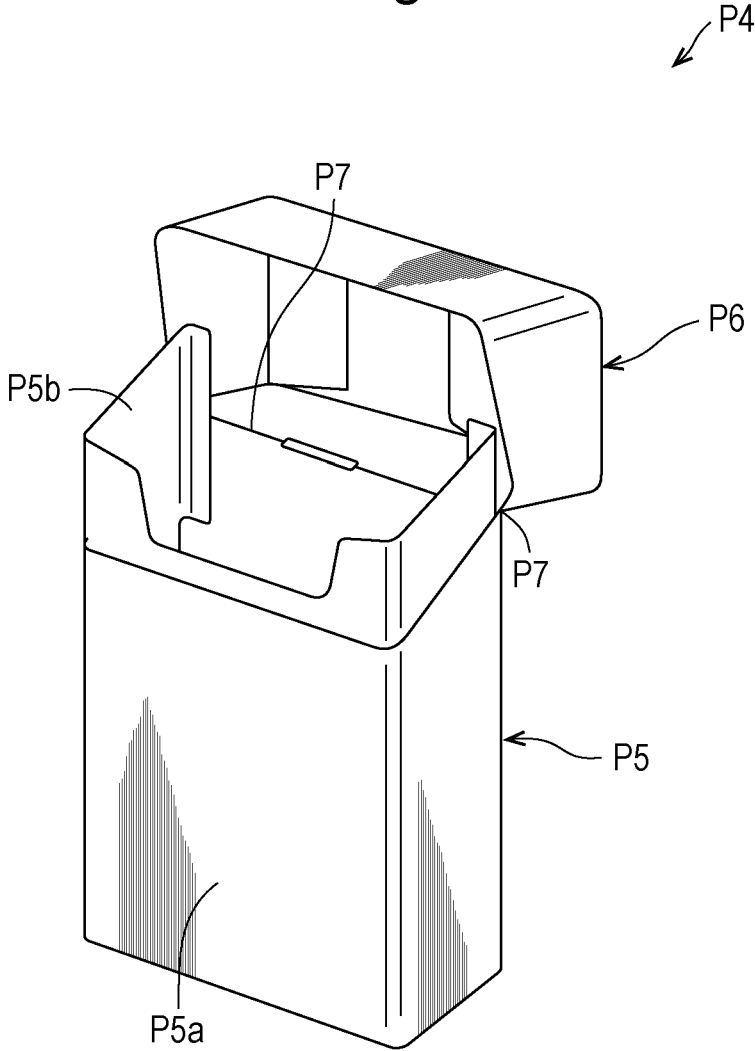

Fig. 8

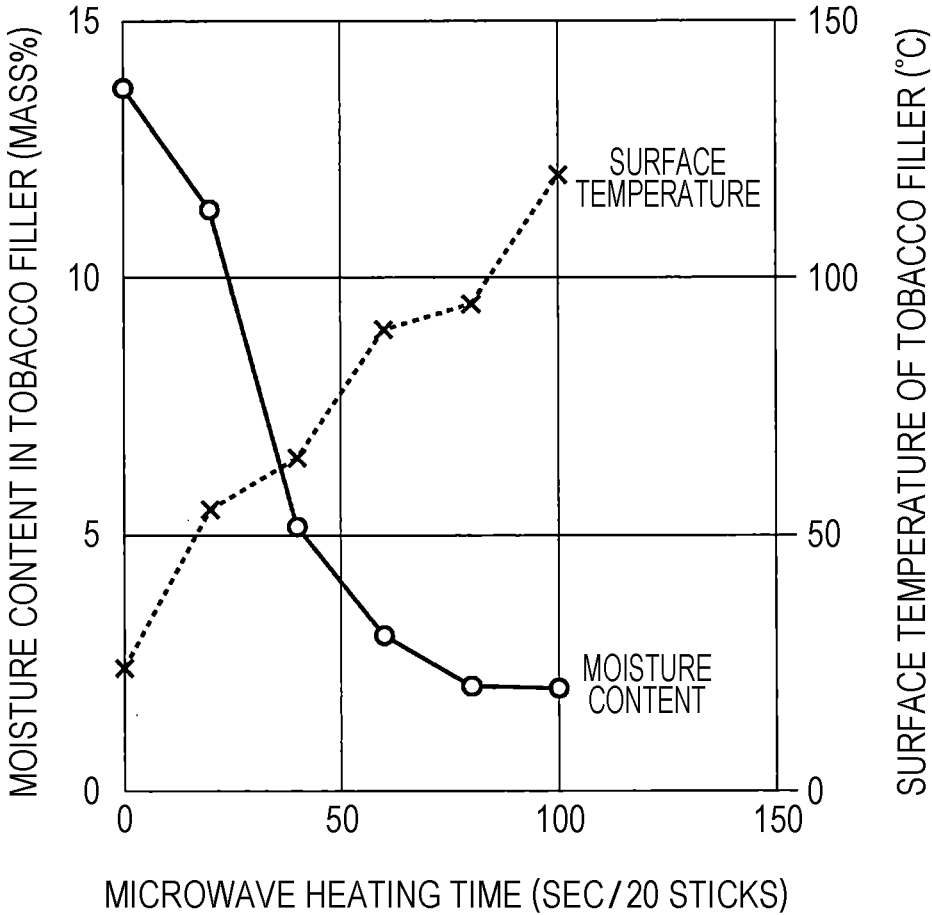

Fig. 9

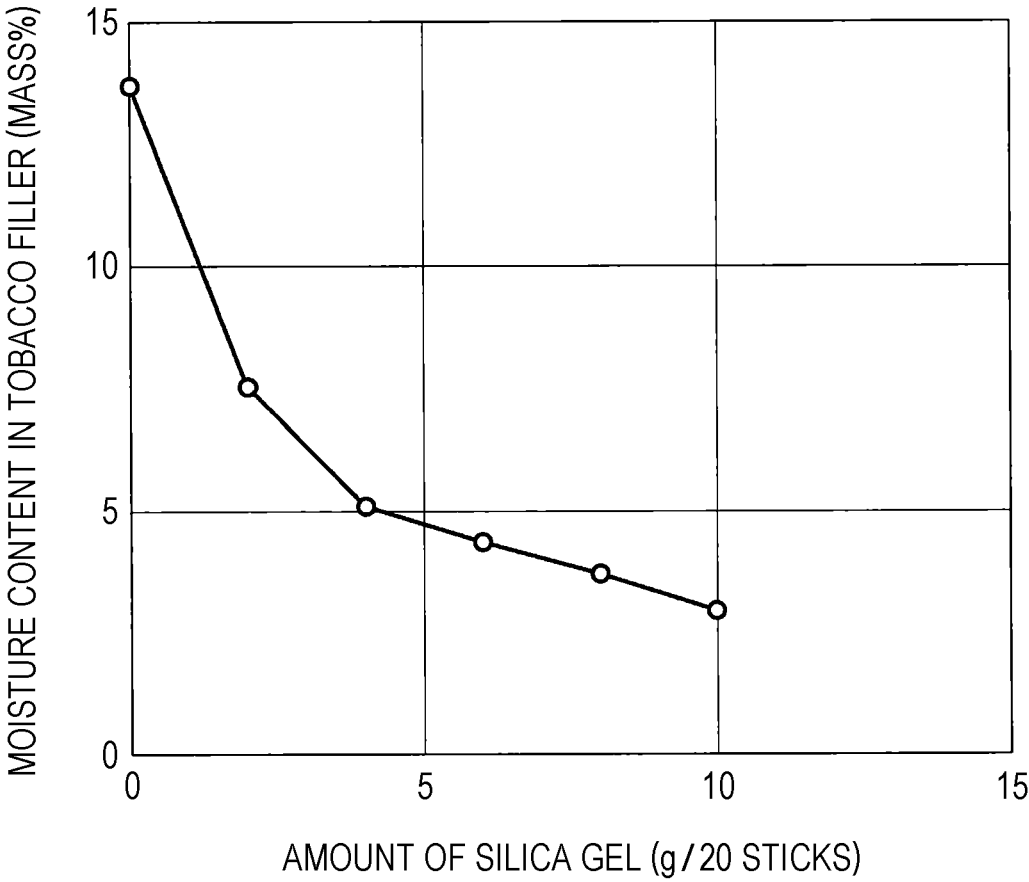

Fig. 10

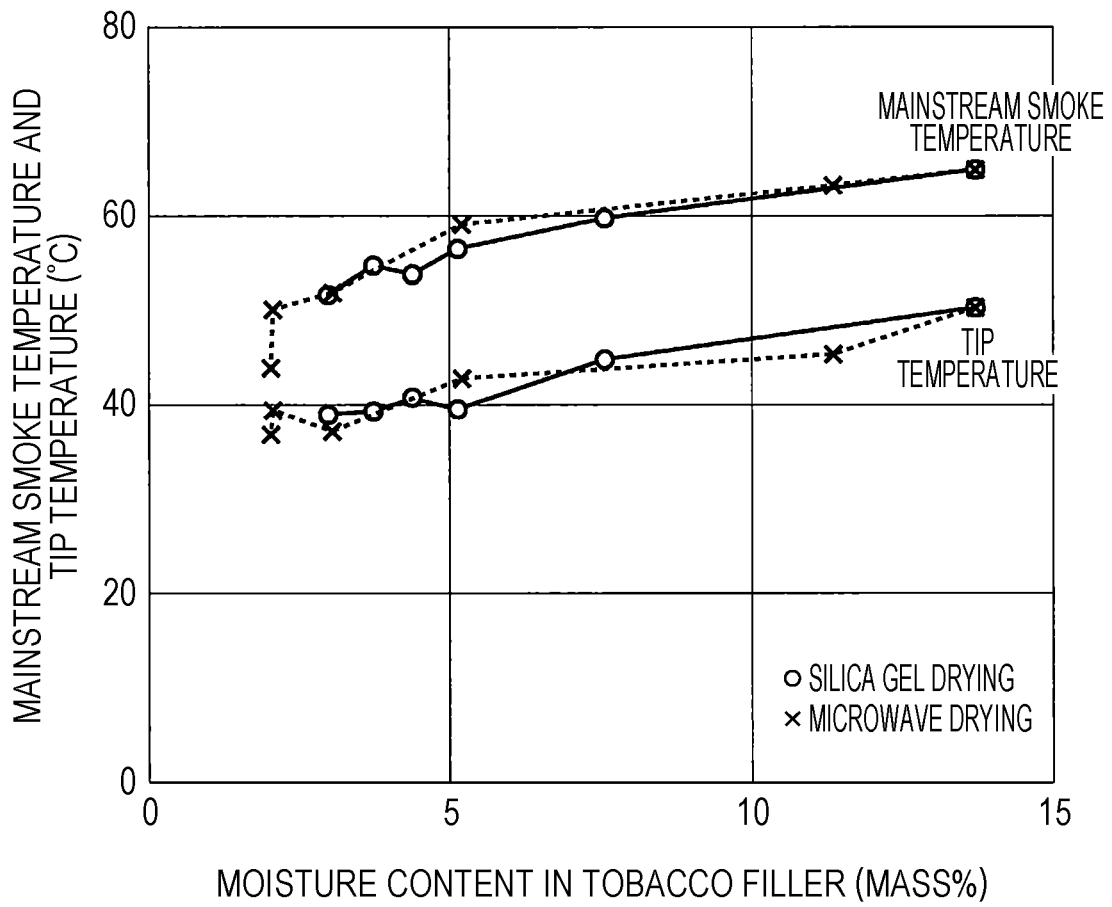

Fig. 11

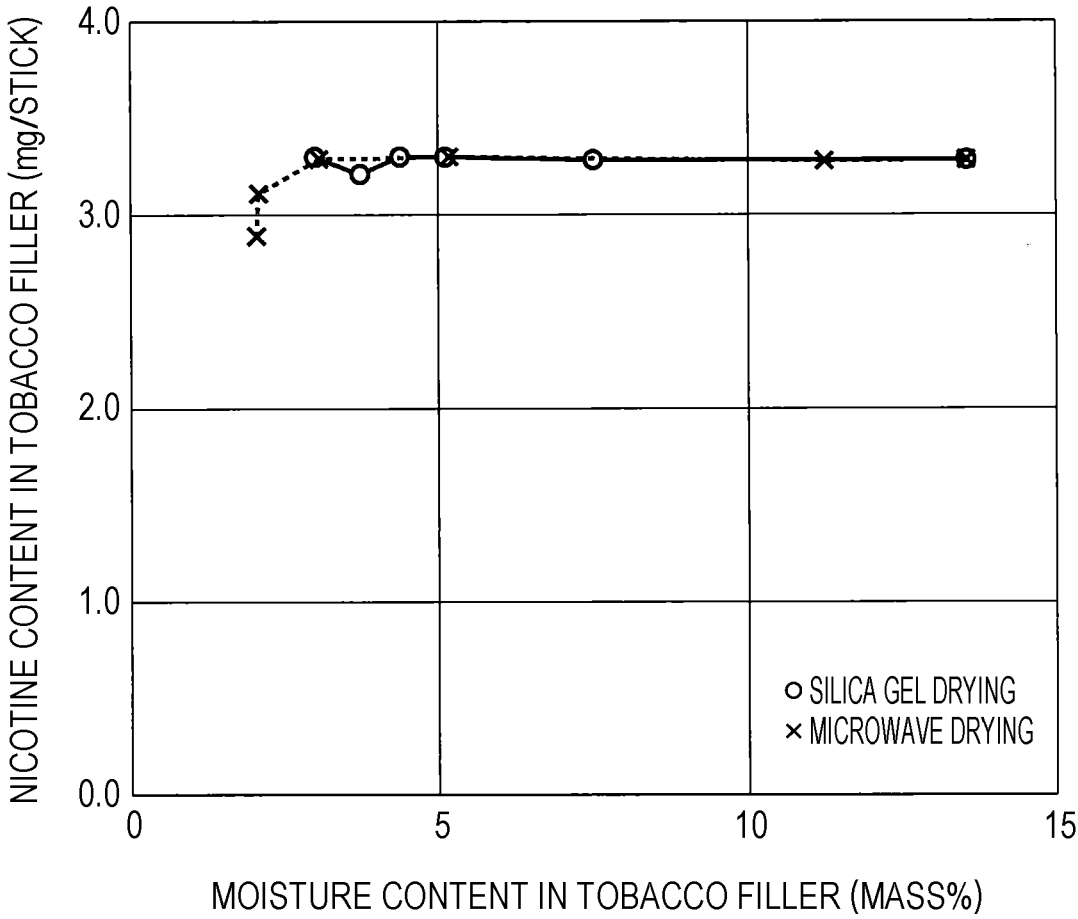

Fig. 12

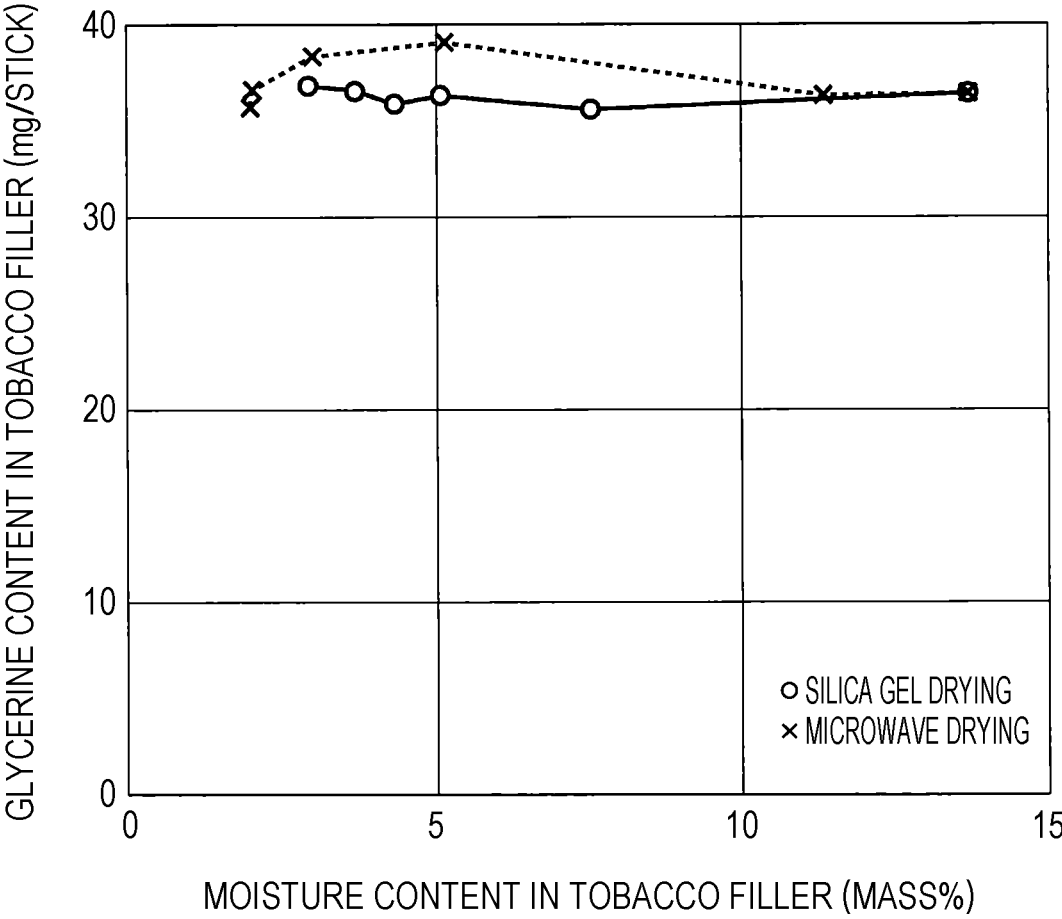

Fig. 13

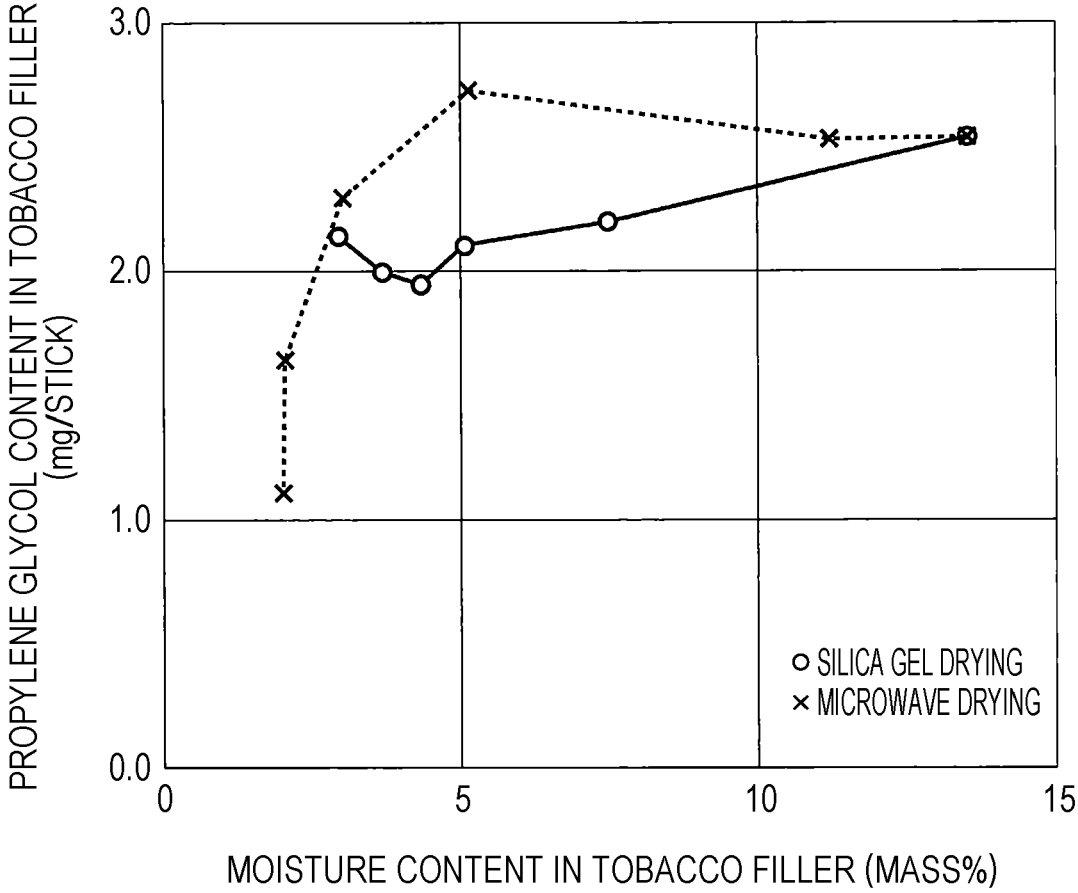

Fig. 14

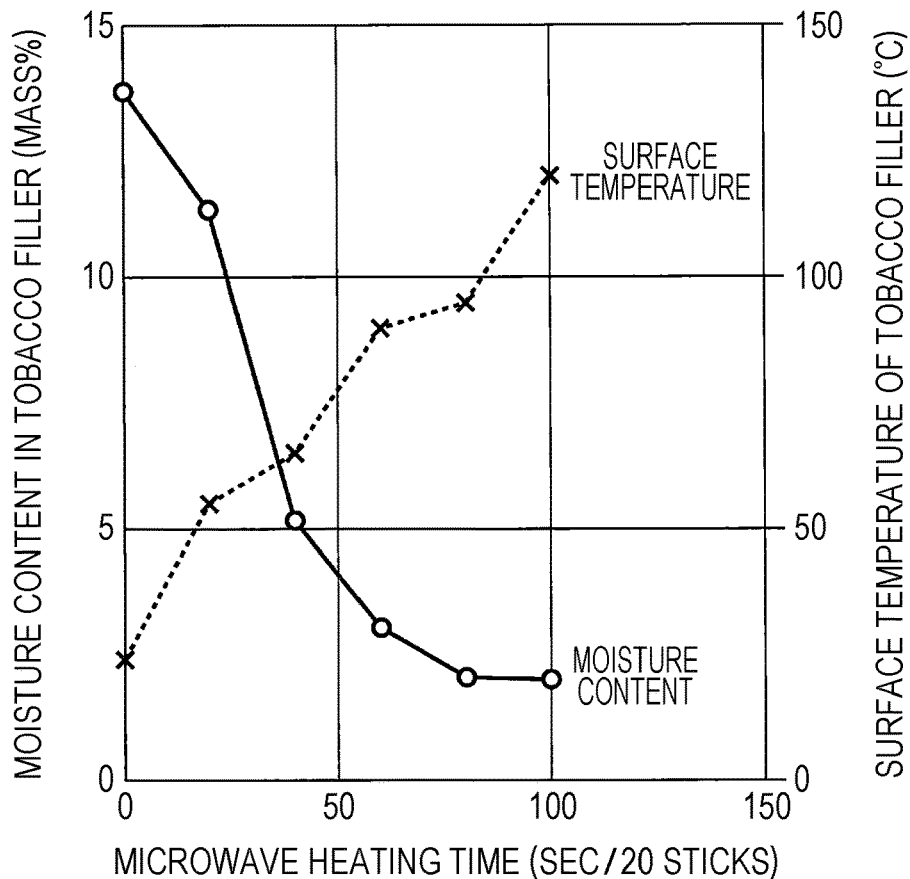

Fig. 15

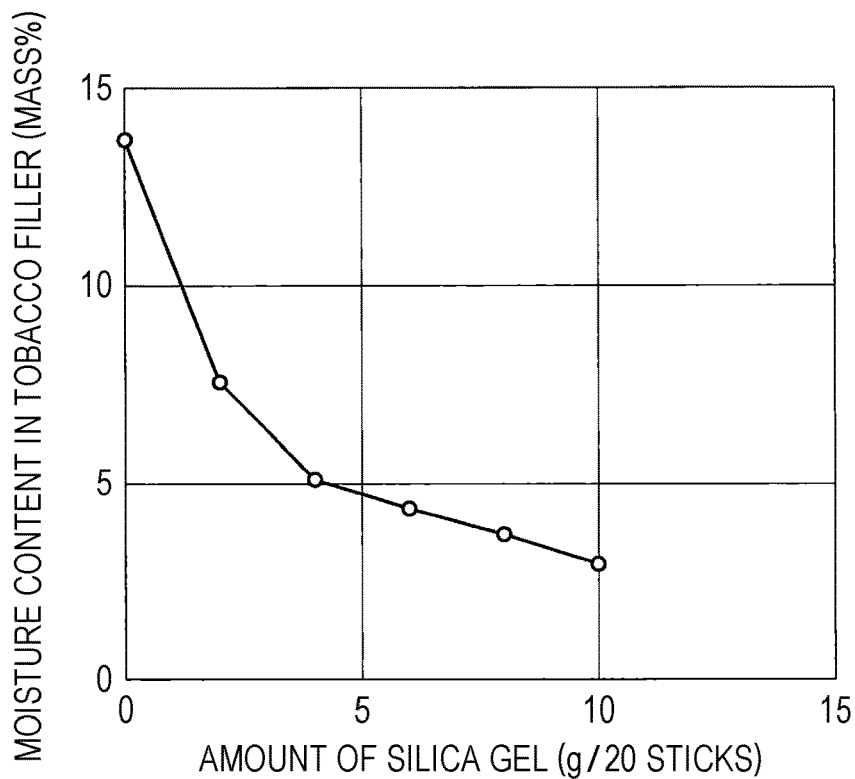

Fig. 16

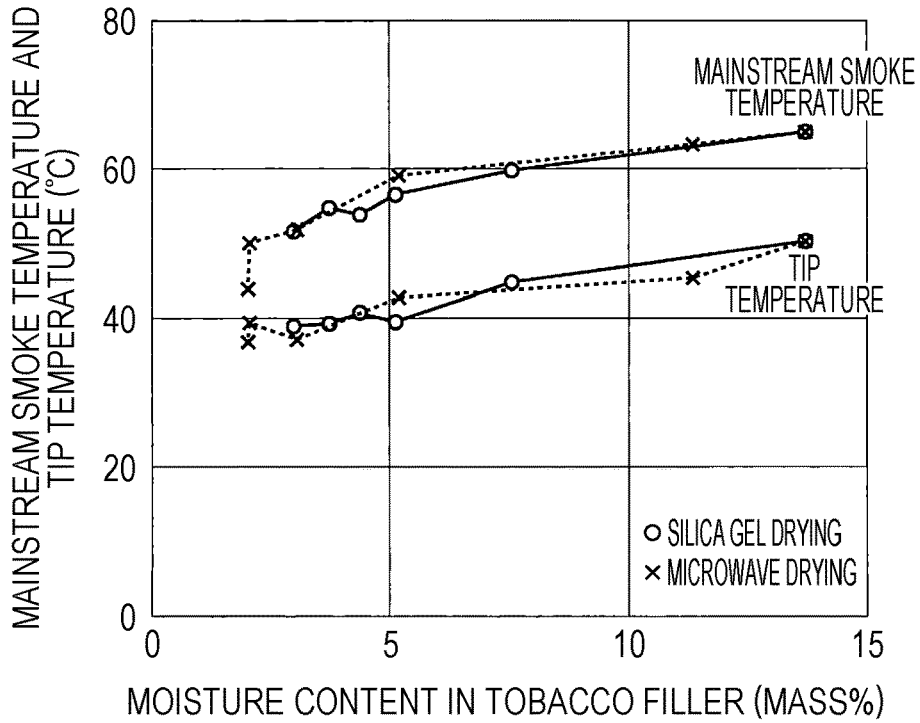

Fig. 17

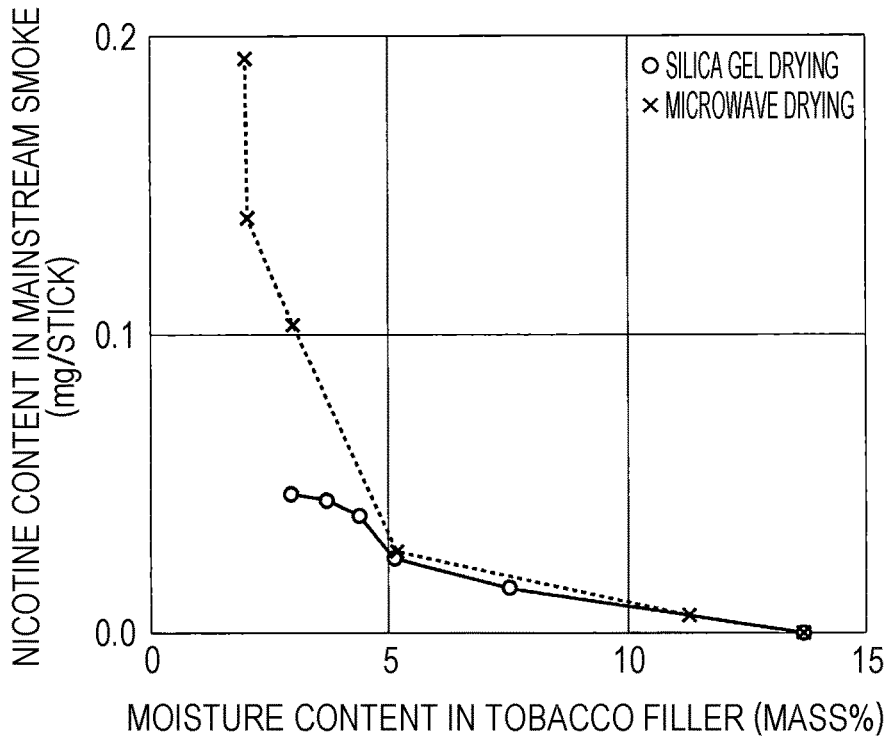

Fig. 18

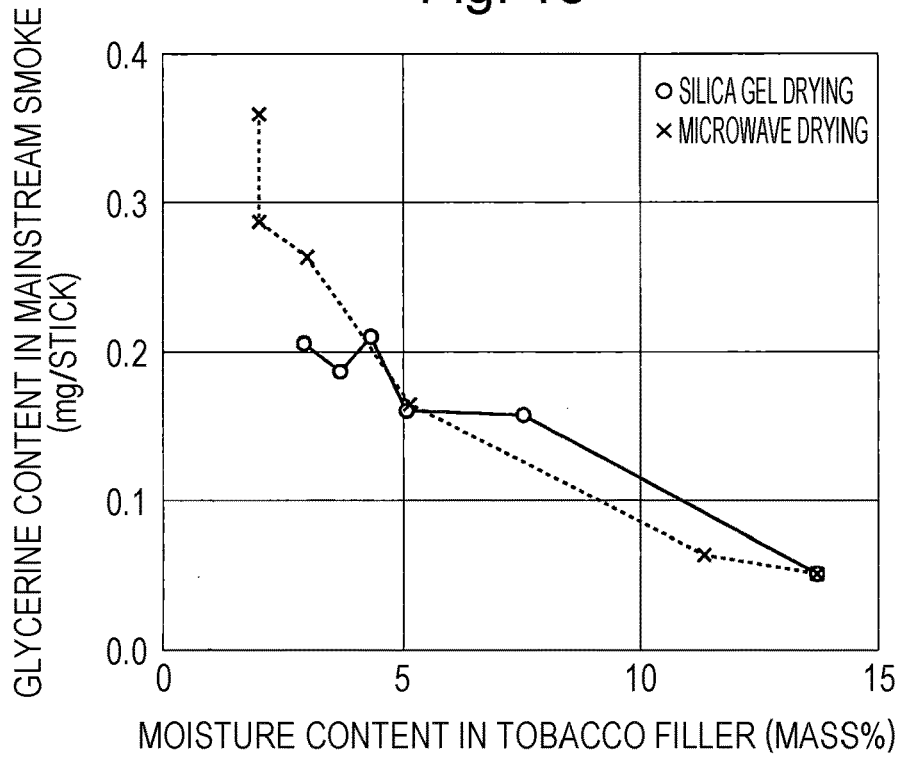

Fig. 19

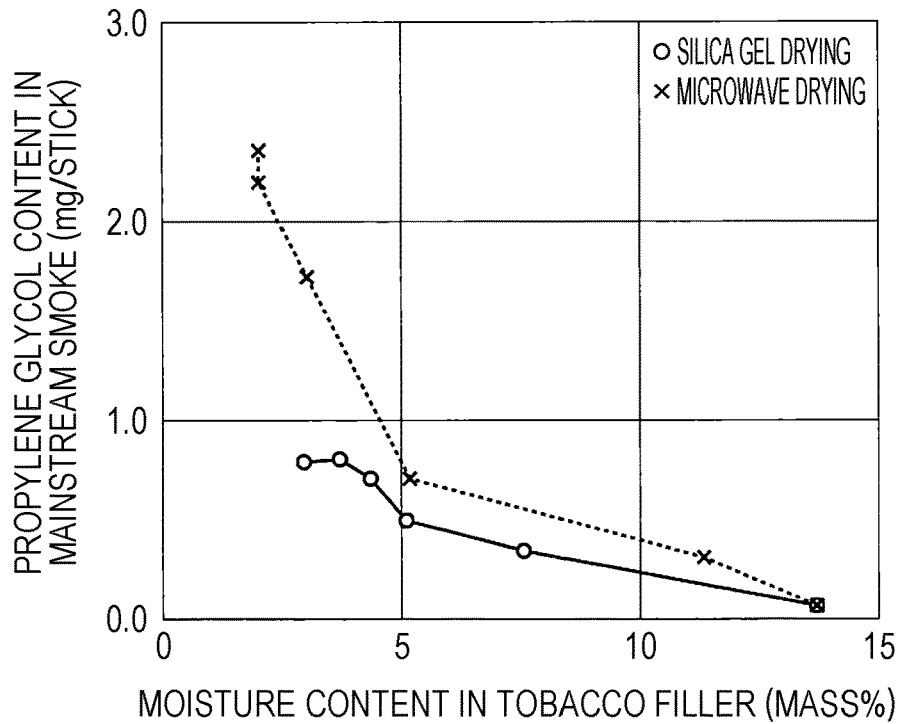

Fig. 20A

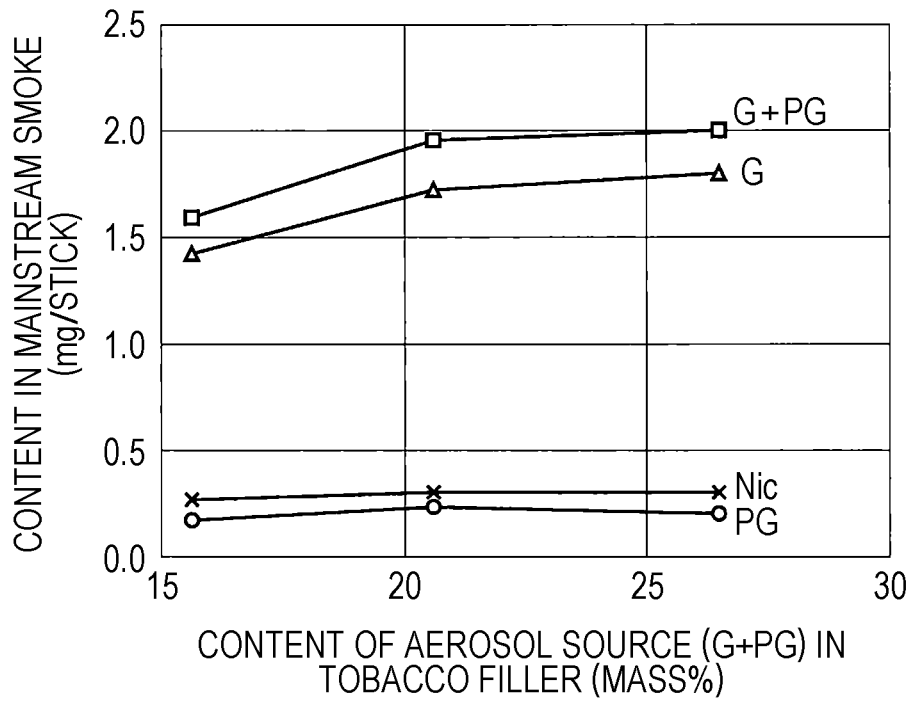

Fig. 20B

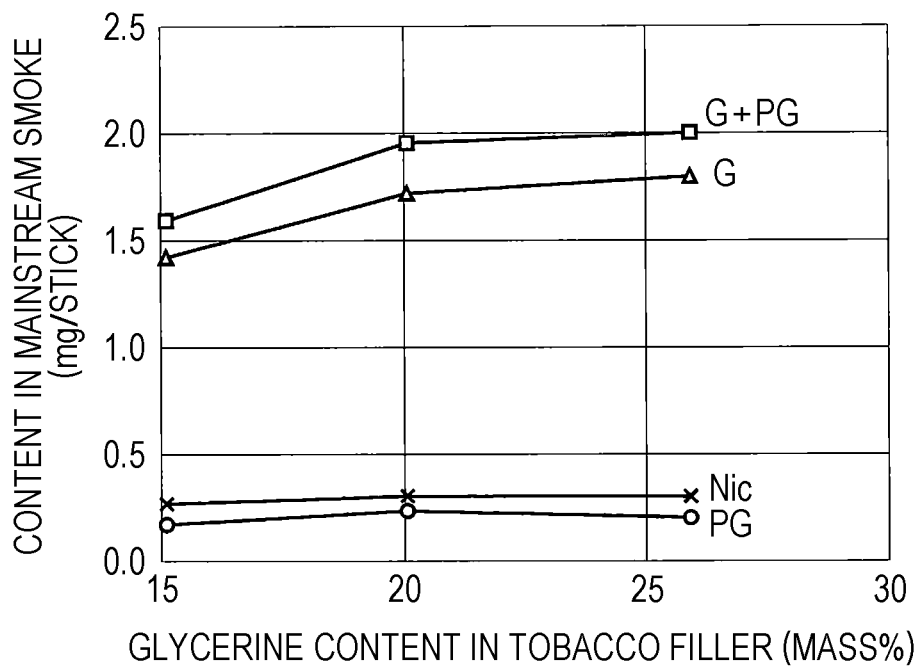

Fig. 21A

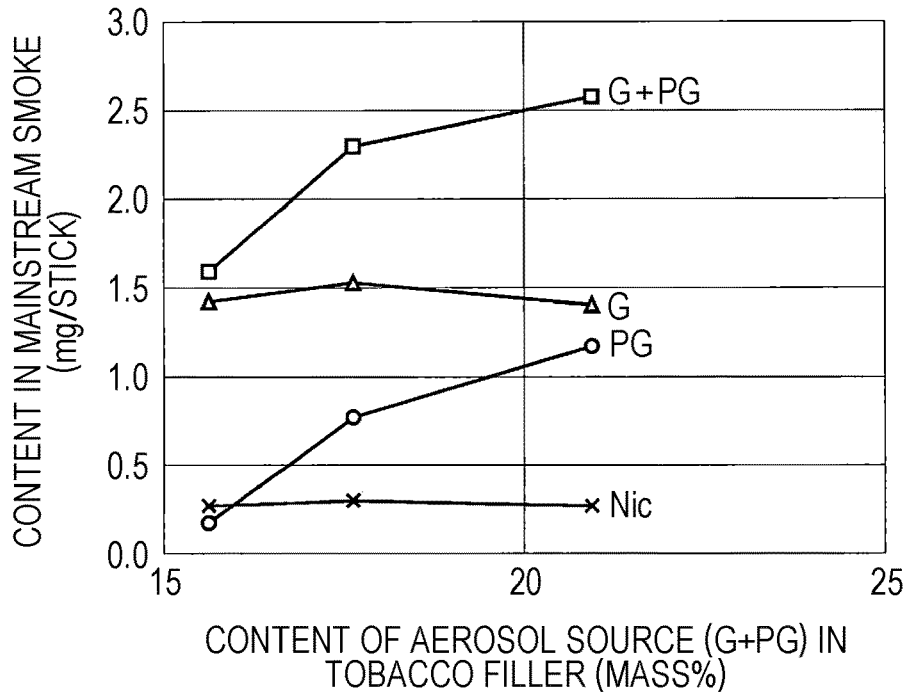
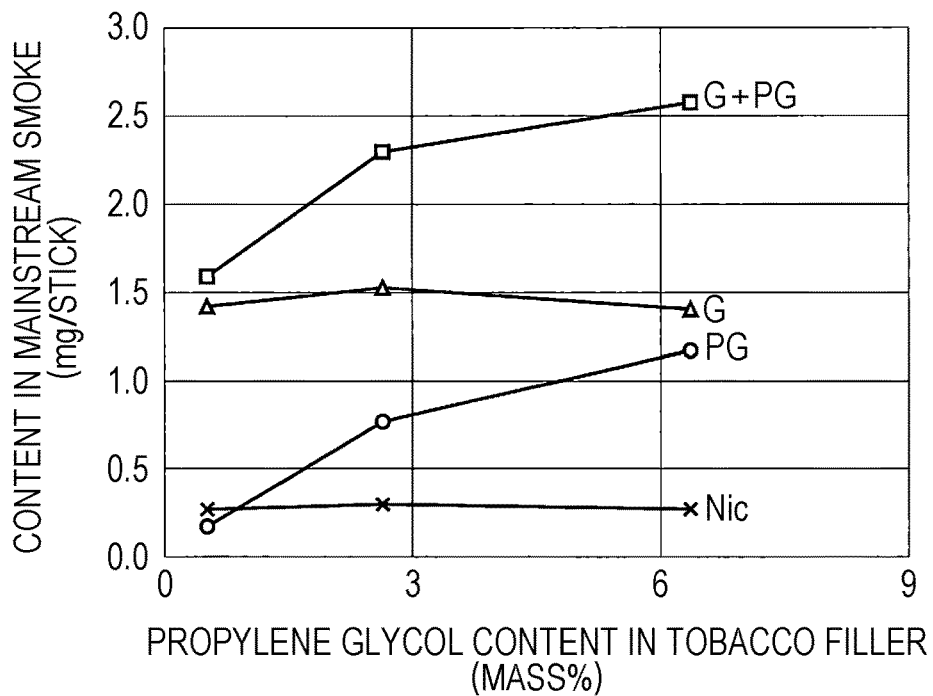

Fig. 21B



**TOBACCO SHEET FOR  
NON-COMBUSTION-HEATING-TYPE  
FLAVOR INHALER,  
NON-COMBUSTION-HEATING-TYPE  
FLAVOR INHALER, AND  
NON-COMBUSTION-HEATING-TYPE  
FLAVOR INHALATION SYSTEM**

CROSS REFERENCES TO RELATED  
APPLICATIONS

**[0001]** The present invention contains subject matter related to PCT Application No. PCT/JP2021/032156 filed on Sep. 1, 2021, PCT Application No. PCT/JP2021/032157 filed on Sep. 1, 2021, Japanese Patent Application No. 2021-170066 filed in the Japan Patent Office on Oct. 18, 2021 and PCT Application No. PCT/JP2022/032765 filed on Aug. 31, 2022, the entire contents of which are incorporated herein by reference.

TECHNICAL FIELD

**[0002]** The present invention relates to a tobacco sheet for non-combustion-heating-type flavor inhalators, a non-combustion-heating-type flavor inhalator, and a non-combustion-heating-type flavor inhalation system.

BACKGROUND ART

**[0003]** In a combustion-type flavor inhalator (i.e., cigarette), a flavor is produced by combusting a tobacco filler including leaf tobacco or a tobacco sheet. For example, PTL 1 discloses a tobacco sheet for combustion-type flavor inhalators. In PTL 1, a non-combustion-heating-type flavor inhalator that produces a flavor by heating a flavor source, such as a tobacco sheet, instead of combusting the flavor source is proposed as an alternative to the combustion-type flavor inhalators. The temperature at which a non-combustion-heating-type flavor inhalator is heated is, for example, about 400° C. or less, which is lower than the temperature at which a combustion-type flavor inhalator is combusted. Since the heating temperature of a non-combustion-heating-type flavor inhalator is low as described above, an aerosol generating agent may be added to the flavor source of a non-combustion-heating-type flavor inhalator in order to increase the amount of smoke generated. Upon being heated, the aerosol generating agent vaporizes to generate an aerosol. Since the aerosol is delivered to the user accompanied by a flavor component, such as a tobacco component, the user can appreciate the flavor at a sufficient level.

**[0004]** A non-combustion-heating-type flavor inhalator may include, for example, a tobacco-containing segment filled with a tobacco sheet or the like, a cooling segment, and a filter segment. The length of the tobacco-containing segment of the non-combustion-heating-type flavor inhalator in the axial direction is commonly smaller than that of the tobacco-containing segment of a combustion-type flavor inhalator in the axial direction due to the relationship between the tobacco-containing segment and the heater. Accordingly, the short tobacco-containing segment of a non-combustion-heating-type flavor inhalator is filled with a large amount of tobacco sheet in order to maintain a certain amount of aerosol generated upon heating. In order to charge a large amount of tobacco sheet into the short segment, a non-combustion-heating-type flavor inhalator commonly includes a tobacco sheet having low bulkiness, that is, a high

density. Note that the term “bulkiness” used herein refers to a value that indicates the volume of shreds of a tobacco sheet having a predetermined mass which have been compressed at a predetermined pressure for a predetermined amount of time. For example, PTL 2 discloses a tobacco sheet for non-combustion-heating-type flavor inhalators.

CITATION LIST

Patent Literature

- [0005]** PTL 1: Japanese Examined Patent Application Publication No. S60-45914  
**[0006]** PTL 2: Japanese Patent No. 5969923

SUMMARY OF INVENTION

Technical Problem

**[0007]** The inventors of the present invention found that, in consideration of the heating method used, the heating capacity of the heater, and generation of aerosol, the tobacco sheet charged in the tobacco-containing segment may not contribute to the generation of aerosol in a sufficient manner depending on the heating method used and the capacity of the heater used because the use of a tobacco sheet having low bulkiness (i.e., a high density) increases the total thermal capacity of the tobacco-containing segment. It is considered that one of the approaches to addressing the above issue is to reduce the total thermal capacity of the tobacco-containing segment.

**[0008]** In order to reduce the total thermal capacity of the tobacco-containing segment, the inventors of the present invention studied a method of (1) reducing the specific heat of the tobacco raw material included in the tobacco sheet, and a method of (2) using a tobacco sheet having high bulkiness (i.e., a low density). Since it is difficult to reduce the specific heat of the tobacco raw material as described in (1), it is considered effective to reduce the total thermal capacity of the tobacco-containing segment by the method (2). Therefore, the development of a high-bulkiness (i.e., low-density) tobacco sheet that can be suitably used for a non-combustion-heating-type flavor inhalator has been anticipated.

**[0009]** Accordingly, an object of the present invention is to provide a tobacco sheet for non-combustion-heating-type flavor inhalators which has high bulkiness, a non-combustion-heating-type flavor inhalator including the tobacco sheet, and a non-combustion-heating-type flavor inhalation system.

Solution to Problem

**[0010]** The present invention includes the following aspects.

Aspect 1

**[0011]** A tobacco sheet for non-combustion-heating-type flavor inhalators, the tobacco sheet including a fibrous material.

Aspect 2

**[0012]** The sheet according to aspect 1, further including a dry tobacco material and an aerosol generating agent, the

dry tobacco material having a moisture content of more than 5% by mass and 7.5% by mass or less.

#### Aspect 3

**[0013]** The sheet according to aspect 2, wherein the aerosol generating agent is a mixture of glycerine and propylene glycol.

#### Aspect 4

**[0014]** The sheet according to aspect 1, further including a dry tobacco material and an aerosol generating agent, a content of the aerosol generating agent in the sheet being less than 20% by mass, the dry tobacco material having a moisture content of 3% to 5% by mass.

#### Aspect 5

**[0015]** The dry tobacco filler according to aspect 4, wherein the aerosol generating agent is a mixture of propylene glycol and glycerine.

#### Aspect 6

**[0016]** A non-combustion-heating-type flavor inhalator including a tobacco-containing segment including the sheet according to any one of aspects 1 to 5.

#### Aspect 7

**[0017]** A non-combustion-heating-type flavor inhalation system including:

- [0018]** the non-combustion-heating-type flavor inhalator according to aspect 6; and
- [0019]** a heating apparatus that heats the tobacco-containing segment.

#### Advantageous Effects of Invention

**[0020]** According to the present invention, a tobacco sheet for non-combustion-heating-type flavor inhalators which has high bulkiness, a non-combustion-heating-type flavor inhalator including the tobacco sheet, and a non-combustion-heating-type flavor inhalation system can be provided.

#### BRIEF DESCRIPTION OF DRAWINGS

**[0021]** FIG. 1 is a cross-sectional view of an example of a non-combustion-heating-type flavor inhalator according to this embodiment.

**[0022]** FIG. 2 includes cross-sectional views of an example of a non-combustion-heating-type flavor inhalation system according to this embodiment, where FIG. 2(a) illustrates the state in which the non-combustion-heating-type flavor inhalator has not been inserted into a heating apparatus, and FIG. 2(b) illustrates the state in which the non-combustion-heating-type flavor inhalator is inserted in the heating apparatus and heated.

**[0023]** FIG. 3 is a diagram schematically illustrating the production of a dry tobacco filler.

**[0024]** FIG. 4 is a perspective view of an example of a non-combustion-heating-type flavor inhalator.

**[0025]** FIG. 5 is a diagram illustrating the internal structure of an aerosol generation apparatus.

**[0026]** FIG. 6 is a perspective view of an example of a cigarette pack, illustrating the state in which the cigarette pack is closed.

**[0027]** FIG. 7 is a perspective view of the cigarette pack illustrated in FIG. 6, illustrating the state in which the cigarette pack is opened.

**[0028]** FIG. 8 includes a graph illustrating the relationship between the amount of time during which heating is performed with a microwave oven and the moisture content in a tobacco filler and a graph illustrating the relationship between the amount of time during which heating is performed with a microwave oven and the surface temperature of the tobacco filler.

**[0029]** FIG. 9 is a graph illustrating the relationship between the amount of silica gel and the moisture content in a tobacco filler.

**[0030]** FIG. 10 includes a graph illustrating the relationship between the moisture content in a tobacco filler and the temperature of a mainstream smoke and a graph illustrating the relationship between the moisture content in the tobacco filler and a tip temperature.

**[0031]** FIG. 11 is a graph illustrating the relationship between the moisture content in a tobacco filler and the content of nicotine in the tobacco filler.

**[0032]** FIG. 12 is a graph illustrating the relationship between the moisture content in a tobacco filler and the content of glycerine in the tobacco filler.

**[0033]** FIG. 13 is a graph illustrating the relationship between the moisture content in a tobacco filler and the content of propylene glycol in the tobacco filler.

**[0034]** FIG. 14 is a graph illustrating the relationship between the amount of time during which heating is performed with a microwave oven and the moisture content in a tobacco filler and a graph illustrating the relationship between the amount of time during which heating is performed with a microwave oven and the surface temperature of the tobacco filler.

**[0035]** FIG. 15 is a graph illustrating the relationship between the amount of silica gel and the moisture content in a tobacco filler.

**[0036]** FIG. 16 includes a graph illustrating the relationship between the moisture content in a tobacco filler and the temperature of a mainstream smoke and a graph illustrating the relationship between the moisture content in the tobacco filler and a tip temperature.

**[0037]** FIG. 17 is a graph illustrating the relationship between the moisture content in a tobacco filler and the content of nicotine in a mainstream smoke.

**[0038]** FIG. 18 is a graph illustrating the relationship between the moisture content in a tobacco filler and the content of glycerine in a mainstream smoke.

**[0039]** FIG. 19 is a graph illustrating the relationship between the moisture content in a tobacco filler and the content of propylene glycol in a mainstream smoke.

**[0040]** FIG. 20A is a graph illustrating the relationship between the content of an aerosol generating agent in a tobacco filler and the content of a component in a mainstream smoke.

**[0041]** FIG. 20B is a graph illustrating the relationship between the content of glycerine in a tobacco filler and the content of a component in a mainstream smoke.

**[0042]** FIG. 21A is a graph illustrating the relationship between the content of an aerosol generating agent in a tobacco filler and the content of a component in a mainstream smoke.

[0043] FIG. 21B is a graph illustrating the relationship between the content of propylene glycol in a tobacco filler and the content of a component in a mainstream smoke.

#### DESCRIPTION OF EMBODIMENTS

[Tobacco Sheet for Non-Combustion-Heating-Type Flavor Inhalators]

[0044] A tobacco sheet for non-combustion-heating-type flavor inhalators according to this embodiment (hereinafter, also referred to as “tobacco sheet”) includes a fibrous material. Since the tobacco sheet according to this embodiment includes a fibrous material, the tobacco sheet is bulky and has a high bulkiness. Thus, the use of the tobacco sheet according to this embodiment reduces the total thermal capacity of the tobacco-containing segment and consequently allows the tobacco sheet charged in the tobacco-containing segment to contribute to the generation of aerosol in a sufficient manner. The tobacco sheet according to this embodiment preferably further includes a tobacco raw material, an aerosol generating agent, and a shaping agent. Adjusting the blending ratios of the above agents to fall within predetermined ranges further enhances the bulkiness of the tobacco sheet.

(Fibrous Material)

[0045] The fibrous material included in the tobacco sheet according to this embodiment is not limited and any fibrous material similar to fibers. Examples of the fibrous material include a fibrous pulp, a fibrous tobacco material, and fibrous synthetic cellulose. The above fibrous materials may be used alone or in combination of two or more. Among these, a fibrous pulp is preferably used as a fibrous material in consideration of fiber stiffness.

[0046] The content of the fibrous material in the tobacco sheet is preferably 5% to 50% by mass with the amount of the tobacco sheet being 100% by mass. When the above content of the fibrous material is 5% by mass or more, the certain bulkiness with which the intended properties are maintained can be achieved. When the above content of the fibrous material is 50% by mass or less, a tobacco flavor and an aerosol can be generated in sufficient amounts upon heating. The content of the fibrous material is more preferably 5% to 47% by mass, is further preferably 5% to 45% by mass, and is particularly preferably 5% to 40% by mass.

(Tobacco Raw Material)

[0047] In the case where the fibrous material is not a fibrous tobacco material, the tobacco sheet according to this embodiment may further include a tobacco raw material. The tobacco raw material may be any material that includes a tobacco component, and examples thereof include a tobacco powder and a tobacco extract. Examples of the tobacco powder include powders of leaf tobacco, midrib, and residual stems. The above materials may be used alone or in combination of two or more. The above materials may be shredded into a predetermined size to be used as a tobacco powder. As for the size of particles of the tobacco powder, the cumulative 90% particle size (D90) of the tobacco powder which is determined using a volume-basis particle size distribution measured by dry laser diffraction is preferably 200  $\mu\text{m}$  or more in order to further enhance bulkiness. Examples of the tobacco extract include a tobacco

extract produced by, for example, crushing leaf tobacco, mixing the resulting coarse particles with a solvent, such as water, stirring the resulting mixture to extract a water-soluble component from the leaf tobacco, and vacuum-drying the resulting water extract to condense the water extract.

[0048] The content of the tobacco raw material in the tobacco sheet is preferably 30% to 91% by mass with the amount of the tobacco sheet being 100% by mass. When the content of the tobacco raw material is 30% by mass or more, a tobacco flavor can be generated in a sufficient manner upon heating. When the content of the tobacco raw material is 91% by mass or less, the contents of the aerosol generating agent and the shaping agent can be increased to sufficient degrees. The content of the tobacco raw material is more preferably 50% to 90% by mass, is further preferably 55% to 85% by mass, and is particularly preferably 60% to 80% by mass.

(Shaping Agent)

[0049] In the case where the fibrous material is not a fibrous shaping agent, such as a fibrous synthetic cellulose, the tobacco sheet according to this embodiment preferably further include a shaping agent in order to maintain shape. Examples of the shaping agent include a polysaccharide, a protein, and a synthetic polymer. The above shaping agents may be used alone or in combination of two or more. Examples of the polysaccharide include a cellulose derivative and a naturally occurring polysaccharide.

[0050] Examples of the cellulose derivative include cellulose ethers, such as methyl cellulose, ethyl cellulose, hydroxyethyl cellulose, hydroxymethyl ethylcellulose, hydroxypropyl cellulose, hydroxypropyl methylcellulose, benzyl cellulose, trityl cellulose, cyanoethyl cellulose, carboxymethyl cellulose, carboxyethyl cellulose, and aminoethyl cellulose; organic acid esters, such as cellulose acetate, cellulose formate, cellulose propionate, cellulose butyrate, cellulose benzoate, cellulose phthalate, and tosyl cellulose; and mineral acid esters, such as cellulose nitrate, cellulose sulfate, cellulose phosphate, and a cellulose xanthogenic acid salt.

[0051] Examples of the naturally occurring polysaccharide include plant-derived polysaccharides, such as a guar gum, a tara gum, a locust bean gum, a tamarind seed gum, pectin, an arabic gum, a tragacanth gum, a karaya gum, a ghatti gum, arabinogalactan, a linseed gum, a cassia gum, a thyrum seed gum, an *Artemisia sphaerocephala* seed gum; algae-derived polysaccharides, such as carrageenan, agar, alginic acid, alginic acid ester of propylene glycol, furcelleran, and *Colpomenia sinuosa* extract; microorganism-derived polysaccharides, such as a xanthan gum, a gellan gum, curdlan, pullulan, agrobacterium succinoglycan, a welan gum, a macrophomopsis gum, and a rhamsan gum; crustacean-derived polysaccharides, such as chitin, chitosan, and glucosamine; and starches, such as starch, sodium starch glycolate, alpha starch, and dextrin.

[0052] Examples of the protein include grain proteins, such as a wheat gluten and a rye gluten. Examples of the synthetic polymer include polyphosphoric acid, sodium polyacrylate, and polyvinylpyrrolidone.

[0053] In the case where the tobacco sheet includes the shaping agent, the content of the shaping agent in the tobacco sheet is preferably 0.1% to 15% by mass with the amount of the tobacco sheet being 100% by mass. When the

above content of the shaping agent is 0.1% by mass or more, it becomes easy to form the mixed body of the raw materials into a sheet-like shape. When the above content of the shaping agent is 15% by mass or less, the amounts of the other materials used for achieving the properties required by the tobacco-containing segment of the non-combustion-heating-type flavor inhalator can be increased to sufficient degrees. The content of the shaping agent is more preferably 0.2% to 13% by mass, is further preferably 0.5% to 12% by mass, and is particularly preferably 1% to 10% by mass.

#### (Aerosol Generating Agent)

**[0054]** The tobacco sheet according to this embodiment preferably further includes an aerosol generating agent in order to increase the amount of smoke generated upon heating. Examples of the aerosol generating agent include glycerine, propylene glycol, and 1,3-butanediol. The above aerosol generating agents may be used alone or in combination of two or more.

**[0055]** In the case where the tobacco sheet includes an aerosol generating agent, the content of the aerosol generating agent in the tobacco sheet is preferably 5% to 50% by mass with the amount of the tobacco sheet being 100% by mass. When the above content of the aerosol generating agent is 5% by mass or more, a sufficient amount of aerosol can be generated upon heating in terms of quantity. When the above content of the aerosol generating agent is 50% by mass or less, a sufficient amount of aerosol can be generated upon heating in terms of thermal capacity. The content of the aerosol generating agent is more preferably 6% to 45% by mass, is further preferably 8% to 40% by mass, and is particularly preferably 10% to 30% by mass.

#### (Reinforcing Agent)

**[0056]** In the case where the fibrous material is not a fibrous reinforcing agent, such as a fibrous pulp, the tobacco sheet according to this embodiment may further include a reinforcing agent in order to further enhance physical properties. Examples of the reinforcing agent include pulps; and liquid substances capable of forming a film when dried, that is, having a surface coating ability, such as a pectin suspension. The above reinforcing agents may be used alone or in combination of two or more.

**[0057]** In the case where the tobacco sheet includes the reinforcing agent, the content of the reinforcing agent in the tobacco sheet is preferably 0.1% to 20% by mass with the amount of the tobacco sheet being 100% by mass. When the content of the reinforcing agent falls within the above range, the amounts of the other materials used for achieving the properties required by the tobacco-containing segment of the non-combustion-heating-type flavor inhalator can be increased to sufficient degrees. The above content of the reinforcing agent is more preferably 0.2% to 18% by mass and is further preferably 0.5% to 15% by mass.

#### (Humectant)

**[0058]** The tobacco sheet according to this embodiment may further include a humectant in order to maintain quality. Examples of the humectant include sugar alcohols, such as sorbitol, erythritol, xylitol, maltitol, lactitol, mannitol, and hydrogenated maltose starch syrup. The above humectants may be used alone or in combination of two or more.

**[0059]** In the case where the tobacco sheet includes a humectant, the content of the humectant in the tobacco sheet is preferably 1% to 15% by mass with the amount of the tobacco sheet being 100% by mass. When the above content falls within the above range, the amounts of the other materials used for achieving the properties required by the tobacco-containing segment of the non-combustion-heating-type flavor inhalator can be increased to sufficient degrees. The above content of the humectant is more preferably 2% to 12% by mass and is further preferably 3% to 10% by mass.

#### (Other Components)

**[0060]** The tobacco sheet according to this embodiment may optionally include, in addition to the fibrous material, the tobacco raw material, the shaping agent, the aerosol generating agent, the reinforcing agent, and the humectant, a flavoring material, such as a flavoring agent or a taste agent, a coloring agent, a wetting agent, a preservative, a diluent, such as an inorganic substance, and the like as needed.

#### (Bulkiness)

**[0061]** The bulkiness of the tobacco sheet according to this embodiment is preferably 190 cc/100 g or more. Setting the above bulkiness to 190 cc/100 g or more reduces the total thermal capacity of the tobacco-containing segment included in the non-combustion-heating-type flavor inhalator to a sufficient degree and allows the tobacco sheet charged in the tobacco-containing segment to further contribute to the generation of aerosol. The above bulkiness is more preferably 210 cc/100 g or more and is further preferably 230 cc/100 g or more. The upper limit for the above bulkiness is not set and may be, for example, 800 cc/100 g or less. Note that the above bulkiness is a value determined by shredding the tobacco sheet to a size of 0.8 mm×9.5 mm, storing the shreds in a conditioning room at 22° C. and 60% for 48 hours, and subsequently analyzing the shreds with “DD-60A” (product name, produced by Burghart Messtechnik GmbH). In the analysis, specifically, 15 g of shreds of the tobacco sheet are charged into a cylindrical container having an inside diameter of 60 mm and compressed at a load of 3 kg for 30 seconds, and the volumetric capacity of the shreds of the tobacco sheet is measured subsequently.

#### (Structure of Tobacco Sheet)

**[0062]** In this embodiment, the “tobacco sheet” is a member produced by forming a component constituting the tobacco sheet into a sheet-like shape. The term “sheet” used herein refers to a shape having a pair of principal surfaces parallel to each other and a side surface. The length and width of the tobacco sheet are not limited and may be adjusted in accordance with the mode in which the tobacco sheet is charged. The thickness of the tobacco sheet is not limited. In consideration of the balance between heat transfer efficiency and strength, the thickness of the tobacco sheet is preferably 100 to 1000 μm and is more preferably 150 to 600 μm.

#### (Method for Producing Tobacco Sheet)

**[0063]** The tobacco sheet according to this embodiment can be produced by a method known in the related art, such as a rolling method or a casting method. Details of the

tobacco sheets produced by the above-described method are disclosed in “Encyclopedia of Tobacco, Tobacco Academic Studies Center, 2009 Mar. 31”.

<Rolling Method>

**[0064]** Examples of the method for producing a tobacco sheet using a rolling method include a method including the following steps.

**[0065]** (1) Mixing water, a tobacco powder, an aerosol generating agent, a shaping agent, and a fibrous pulp together to prepare a mixture

**[0066]** (2) Charging the mixture into reduction rollers and rolling the mixture

**[0067]** (3) Removing the rolled article formed on the reduction rollers with a doctor blade, transferring the rolled article to a net conveyer, and drying the rolled article with a drier.

**[0068]** In the case where the tobacco sheet is produced by the above-described method, optionally, the surfaces of the reduction rollers may be heated or cooled depending on the intended purpose. In another case, the rotational speed of the reduction rollers may be adjusted. Adjusting the intervals of the reduction rollers enables the production of a tobacco sheet having an intended basis weight.

<Casting Method>

**[0069]** Examples of the method for producing a tobacco sheet using a casting method include a method including the following steps.

**[0070]** (1) Mixing water, a tobacco powder, an aerosol generating agent, a shaping agent, and a fibrous pulp together to prepare a mixture

**[0071]** (2) Spreading (i.e., casting) the mixture thinly and drying the resulting sheet to form a tobacco sheet.

**[0072]** In the case where the tobacco sheet is produced by the above-described method, optionally, the slurry prepared by mixing water, a tobacco powder, an aerosol generating agent, a shaping agent, and a fibrous pulp together may be irradiated with an ultraviolet ray or an X-ray in order to remove some components, such as nitrosamine.

[Non-Combustion-Heating-Type Flavor Inhalator]

**[0073]** A non-combustion-heating-type flavor inhalator according to this embodiment includes a tobacco-containing segment that includes the tobacco sheet according to this embodiment. Since the non-combustion-heating-type flavor inhalator according to this embodiment includes a tobacco-containing segment filled with the tobacco sheet according to this embodiment, which has high bulkiness, the total thermal capacity of the tobacco-containing segment can be reduced to a sufficient degree and the tobacco sheet charged in the tobacco-containing segment can further contribute to aerosol generation.

**[0074]** FIG. 1 illustrates an example of the non-combustion-heating-type flavor inhalator according to this embodiment. The non-combustion-heating-type flavor inhalator 1 illustrated in FIG. 1 includes a tobacco-containing segment 2 filled with the tobacco sheet according to this embodiment, a tubular cooling segment 3 having perforations 8 formed on the periphery thereof, a center-hole segment 4, and a filter segment 5. The non-combustion-heating-type flavor inhalator according to this embodiment may include segments

other than any of the tobacco-containing segment, the cooling segment, the center-hole segment, and the filter segment.

**[0075]** The length of the non-combustion-heating-type flavor inhalator according to this embodiment in the axial direction is preferably, but not limited to, 40 mm or more and 90 mm or less, is more preferably 50 mm or more and 75 mm or less, and is further preferably 50 mm or more and 60 mm or less. The perimeter of the non-combustion-heating-type flavor inhalator is preferably 16 mm or more and 25 mm or less, is more preferably 20 mm or more and 24 mm or less, and is further preferably 21 mm or more and 23 mm or less. In an aspect, for example, the tobacco-containing segment may have a length of 20 mm, the cooling segment may have a length of 20 mm, the center-hole segment may have a length of 8 mm, and the filter segment may have a length of 7 mm. The length of the filter segment may be selected so as to fall within the range of 4 mm or more and 10 mm or less. In such a case, the airflow resistance of the filter segment per segment may be selected so as to fall within the range of 15 mmH<sub>2</sub>O/seg or more and 60 mmH<sub>2</sub>O/seg or less. The lengths of the above segments may be changed appropriately in accordance with manufacturability, intended qualities, and the like. Alternatively, only the filter segment may be arranged downstream of the cooling segment without using the center-hole segment. Even in such a case, the performance of the non-combustion-heating-type flavor inhalator can be achieved.

(Tobacco-Containing Segment)

**[0076]** The tobacco-containing segment 2 includes the tobacco sheet according to this embodiment and a wrapping paper (hereinafter, also referred to as “wrapper”) in which the tobacco sheet is charged. The method for charging the tobacco sheet into the wrapping paper is not limited. For example, the tobacco sheet may be wrapped with the wrapper. Alternatively, the tobacco sheet may be charged into a tubular wrapper. In the case where the shape of the tobacco sheet has a longitudinal direction, such as a rectangular shape, the tobacco sheet may be charged into the wrapper such that the longitudinal direction of the tobacco sheet is not aligned in a specific direction inside the wrapper. In another case, the tobacco sheet may be charged into the wrapper so as to be aligned in the axial direction of the tobacco-containing segment 2 or a direction perpendicular to the above axial direction. The tobacco sheet may be incorporated into the wrapper while stacked on top of one another, wound in a spiral manner, or folded in an accordion manner.

(Cooling Segment)

**[0077]** For example, the cooling segment 3 includes a tubular member 7 as illustrated in FIG. 1. The tubular member 7 may be, for example, a paper tube prepared by forming a paperboard into a cylindrical shape.

**[0078]** The tubular member 7 and a mouthpiece lining paper 12, which is described below, have perforations 8 arranged to penetrate through the tubular member 7 and the mouthpiece lining paper 12. The presence of the perforations 8 enables the outside air to be introduced into the cooling segment 3 upon inhalation. As a result, the vaporized aerosol component generated upon heating of the tobacco-containing segment 2 is brought into contact with the outside air, which reduces the temperature of the vaporized aerosol

component. Consequently, the vaporized aerosol component liquifies and forms an aerosol. The diameter of the perforations **8** (i.e., the distance across each of the perforations **8**) is not limited and may be, for example, 0.5 mm or more and 1.5 mm or less. The number of the perforations **8** is not limited and may be one or more. For example, a plurality of the perforations **8** may be formed on the periphery of the cooling segment **3**.

**[0079]** The amount of the outside air introduced through the perforations **8** is preferably 85% by volume or less and is more preferably 80% by volume or less of the total volume of the gas inhaled by the user. When the proportion of the above outside air is 85% by volume or less, flavor degradation caused by dilution with the outside air can be limited in a sufficient manner. The above proportion is also referred to as “ventilation ratio”. The lower limit for the ventilation ratio is preferably 55% by volume or more and is more preferably 60% by volume or more in consideration of cooling performance.

**[0080]** The cooling segment may be a segment that includes a wrinkled, pleated, gathered, or folded sheet composed of an appropriate material. The cross section profile of such an element may appear as randomly oriented channels. The cooling segment may include a bundle of tubes that extend in the longitudinal direction. Such a cooling segment can be formed by, for example, wrapping a pleated, gathered, or folded sheet material with a wrapping paper.

**[0081]** The length of the cooling segment in the axial direction may be, for example, 7 mm or more and 28 mm or less and may be, for example, 18 mm. The cross-sectional shape of the cooling segment in the axial direction may be substantially circular. The diameter of the cooling segment may be, for example, 5 mm or more and 10 mm or less and may be, for example, about 7 mm.

(Center-Hole Segment)

**[0082]** The center-hole segment is constituted by a filler layer having one or a plurality of hollow parts and an inner plug wrapper (i.e., inner wrapping paper) that covers the filler layer. For example, as illustrated in FIG. 1, a center-hole segment **4** is constituted by a second filler layer **9** having a hollow part and a second inner plug wrapper **10** that covers the second filler layer **9**. The center-hole segment **4** increases the strength of the mouthpiece segment **6**. The second filler layer **9** may be, for example, a rod having an inside diameter of 1.0 mm or more and 5.0 mm or less which is filled with cellulose acetate fibers at a high density and hardened by the addition of 6% by mass or more and 20% by mass or less of a plasticizer including triacetin relative to the mass of the cellulose acetate. Since the pack density of fibers in the second filler layer **9** is high, the air and aerosol flow through only the hollow part upon inhalation and hardly flow inside the second filler layer **9**. Since the second filler layer **9** disposed inside the center-hole segment **4** is a layer filled with fibers, the user is unlikely to sense incongruity when touching the outside portion of the center-hole segment during use. The center-hole segment **4** does not necessarily include the second inner plug wrapper **10**; alternatively, thermoforming may be performed to maintain the shape of the center-hole segment **4**.

(Filter Segment)

**[0083]** The structure of the filter segment **5** is not limited. The filter segment **5** may be constituted by one or a plurality

of filler layers. The outside portion of the filler layer may be wrapped with one or a plurality of wrapping papers. The airflow resistance of the filter segment **5** per segment may be changed appropriately in accordance with, for example, the amount and type of the filler charged in the filter segment **5**. For example, in the case where the filler is a cellulose acetate fiber, the above airflow resistance can be increased by increasing the amount of the cellulose acetate fiber charged in the filter segment **5**. In the case where the filler is a cellulose acetate fiber, the pack density of the cellulose acetate fiber may be 0.13 to 0.18 g/cm<sup>3</sup>. Note that the above airflow resistance is a value measured with an airflow resistance gage (product name: “SODIMAX”, produced by SODIM).

**[0084]** The perimeter of the filter segment **5** is preferably, but not limited to, 16 to 25 mm, is more preferably 20 to 24 mm, and is further preferably 21 to 23 mm. The length of the filter segment **5** in the axial direction may be selected so as to fall within the range of 4 to 10 mm such that the airflow resistance thereof is 15 to 60 mmH<sub>2</sub>O/seg. The length of the filter segment **5** in the axial direction is preferably 5 to 9 mm and is more preferably 6 to 8 mm. The shape of the cross section of the filter segment **5** is not limited and may be, for example, circular, oval, polygonal, or the like. Optionally, a destructible capsule or flavoring agent bead that includes a flavoring agent or a flavoring agent may be added directly to the filter segment **5**.

**[0085]** As illustrated in FIG. 1, the center-hole segment **4** and the filter segment **5** can be connected to each other with an outer plug wrapper (i.e., outer wrapping paper) **11**. The outer plug wrapper **11** may be, for example, a cylindrical paper. The tobacco-containing segment **2**, the cooling segment **3**, and the center-hole segment **4** and the filter segment **5** that have been connected to each other can be connected to one another with a mouthpiece lining paper **12**. The above segments can be connected to one another by, for example, applying a paste, such as a vinyl acetate paste, onto the inside surface of the mouthpiece lining paper **12** and winding the mouthpiece lining paper **12** around the three segments. Note that, alternatively, the above segments may be connected to one another with a plurality of lining papers in a plurality of stages.

[Non-Combustion-Heating-Type Flavor Inhalation System]

**[0086]** A non-combustion-heating-type flavor inhalation system according to this embodiment includes the non-combustion-heating-type flavor inhalator according to this embodiment and a heating apparatus that heats the tobacco-containing segment of the non-combustion-heating-type flavor inhalator. The non-combustion-heating-type flavor inhalation system according to this embodiment may include a component other than the non-combustion-heating-type flavor inhalator according to this embodiment or the heating apparatus.

**[0087]** FIG. 2 illustrates an example of the non-combustion-heating-type flavor inhalation system according to this embodiment. The non-combustion-heating-type flavor inhalation system illustrated in FIG. 2 includes a non-combustion-heating-type flavor inhalator **1** according to this embodiment and a heating apparatus **13** that heats the outside portion of the tobacco-containing segment of the non-combustion-heating-type flavor inhalator **1**.

**[0088]** FIG. 2(a) illustrates the state in which the non-combustion-heating-type flavor inhalator **1** has not been

inserted into the heating apparatus 13, while FIG. 2(b) illustrates the state in which the non-combustion-heating-type flavor inhalator 1 is inserted in the heating apparatus 13 and heated. The heating apparatus 13 illustrated in FIG. 2 includes a body 14, a heater 15, a metal pipe 16, a battery unit 17, and a control unit 18. The body 14 has a tubular recess 19 formed therein. A heater 15 and a metal pipe 16 are disposed on a portion of the inside surface of the recess 19 which is to face the tobacco-containing segment of the non-combustion-heating-type flavor inhalator 1 inserted into the recess 19. The heater 15 may be an electric resistance heater. In response to a command from the control unit 18, which is responsible for temperature control, electric power is fed from the battery unit 17 and the heater 15 is heated. The heat generated by the heater 15 is transferred to the tobacco-containing segment of the non-combustion-heating-type flavor inhalator 1 through the metal pipe 16, which has a high thermal conductivity.

[0089] Although a gap is present between the outer circumference of the non-combustion-heating-type flavor inhalator 1 and the inner circumference of the metal pipe 16 in FIG. 2(b), which is a schematical diagram, a gap is desirably absent between the outer circumference of the non-combustion-heating-type flavor inhalator 1 and the inner circumference of the metal pipe 16 in reality for efficient heat transfer. Although the heating apparatus 13 heats the outside portion of the tobacco-containing segment of the non-combustion-heating-type flavor inhalator 1, the heating apparatus 13 may heat the inside portion of the tobacco-containing segment.

[0090] The temperature at which heating is performed with the heating apparatus is not limited. The above heating temperature is preferably 400° C. or less, is more preferably 150° C. or more and 400° C. or less, and is further preferably 200° C. or more and 350° C. or less. Note that the above heating temperature is the temperature of a heater included in the heating apparatus.

[0091] The inventors of the present invention further found another issue that the user senses the heat of the aerosol or the heat of the mouthpiece end of the article upon inhalation because, in the non-combustion-heating-type flavor inhalator, the moisture included in the tobacco material and the vapor generated from the aerosol generating agent upon heating do not diffuse from the front end of the article unlike smoking articles, such as cigarettes. Accordingly, a tobacco sheet with which a non-combustion-heating-type flavor inhalator that reduces the likelihood of the user sensing the heat of the aerosol or the heat of the mouthpiece end of the article upon inhalation, that is excellent in terms of quality stability of the tobacco filler, and that further enhances the user satisfaction can be produced is described below as a first aspect.

[0092] Furthermore, a tobacco sheet with which a non-combustion-heating-type flavor inhalator that reduces the likelihood of the user sensing the heat of the aerosol or the heat of the mouthpiece end of the article upon inhalation and that enhances the feel of smoking can be produced is also described below as a second aspect.

[First Aspect]

[0093] A tobacco sheet according to this aspect is formed of a fibrous material and a dry tobacco filler including a dry tobacco material and an aerosol generating agent, the dry tobacco filler having a moisture content of more than 5% by mass and 7.5% by mass or less. In the present description,

the sheet may include, but does not necessarily include, a component other than the fibrous material or the dry tobacco filler, and the aerosol generating agent may be referred to as “aerosol source”. The content of the dry tobacco filler in the sheet is preferably less than 50% by mass, is more preferably 5% to 45% by mass, and is further preferably 10% to 30% by mass. The filler is a material with which the tobacco segment is filled.

#### 1. Dry Tobacco Filler

[0094] According to an example of the aspect, a tobacco sheet formed of a fibrous material and a dry tobacco filler including a dry tobacco material and an aerosol generating agent, the dry tobacco filler having a moisture content of more than 5% by mass and 7.5% by mass or less, is provided.

[0095] The moisture content in the “dry tobacco filler” is more than 5% by mass and 7.5% by mass or less, is preferably 5.1% to 7.5% by mass, is more preferably 5.1% to 7.0% by mass, and is further preferably 5.5% to 7.0% by mass. In the present description, the “moisture content in the dry tobacco filler” is the proportion (% by mass) of the mass of moisture to the total mass of the dry tobacco filler.

[0096] The “dry tobacco filler” may be prepared by drying a “tobacco filler included in an existing non-combustion-heating-type flavor inhalator (hereinafter, such a tobacco filler is also referred to as “untreated tobacco filler”)” as illustrated in FIG. 3. An untreated tobacco filler T3a includes a tobacco material T1a and an aerosol generating agent T2 and commonly has a moisture content of 10% to 15% by mass. Note that the “moisture content in the untreated tobacco filler” is also the proportion (% by mass) of the mass of moisture to the total mass of the untreated tobacco filler. When the untreated tobacco filler T3a is dried, the moisture included in the tobacco material T1a is removed and a dry tobacco filler T3b can be prepared consequently. Therefore, in the present description, the tobacco material included in the “dry tobacco filler” is referred to as “dry tobacco material”. When the untreated tobacco filler T3a is dried, the tobacco material T1a is converted to the dry tobacco material T1b as a result of the moisture removal, while most of the aerosol generating agent T2 is not removed and remains. The aerosol generating agent T2 may be present on the surface of the tobacco material T1a or the dry tobacco material T1b or permeate the tobacco material T1a or the dry tobacco material T1b to be incorporated therein.

[0097] Specifically, the “tobacco material T1a” included in the untreated tobacco filler T3a may be a shredded tobacco ready to be added to a tobacco product or a tobacco molded body prepared by forming a raw material including the shredded tobacco into an intended shape. The “shredded tobacco ready to be added to a tobacco product” is commonly prepared through various processes, such as drying in a farm, subsequent long-term aging for one to a few years in a raw material factory, and subsequent blending and shredding in a production facility. Note that the “shredded tobacco ready to be added to a tobacco product” may be any of shreds of rib-removed leaves, shreds of midrib, shreds of regeneration tobacco (i.e., a tobacco material prepared by forming leaf dust, shred dust, midrib dust, fine powder particles, and the like produced in the processes performed in a factory into a reusable shape), and a mixture thereof.

[0098] The “tobacco material T1a” is preferably a tobacco molded body. The tobacco molded body may include, in

addition to shredded tobacco, tobacco dust particles produced in a raw material factory or production facility, such as leave dust particles and shred dust particles. The tobacco molded body may be formed in a size appropriate for non-combustion-heating-type flavor inhalators. In another case, the tobacco molded body is formed in a large size and subsequently cut to a size appropriate for non-combustion-heating-type flavor inhalators. The shape of the tobacco molded body is not limited, may be, for example, a circular cylinder or a square pole, is preferably a hexahedron, is more preferably a rectangular parallelepiped, and is further preferably a square prism.

**[0099]** The tobacco molded body is a molded body prepared by forming a raw material including shredded tobacco into a shape. Examples of the tobacco molded body include a tobacco sheet and tobacco granules. The sheet can be formed by a method known in the related art, such as a sheet making method, a casting method, or a rolling method. The “tobacco granules” are molded articles produced by forming a raw material including shredded tobacco into a granular shape. The tobacco granules can be produced by a method known in the related art, such as extruding granulation, fluidized-bed granulation, or spray drying.

**[0100]** The tobacco molded body may include at least one binder selected from the group consisting of pullulan and hydroxypropyl cellulose in order to maintain the shape of the molded body. The content of the binder may be set such that the advantageous effects of the binder can be produced and the likelihood of the tobacco flavor component being released is not reduced. The content of the binder is commonly 0.5% to 15% by mass of the total mass of the tobacco molded body. The tobacco molded body does not necessarily include a binder in the case where the shape of the tobacco molded body can be maintained without using a binder. In the case where the binder inhibits a tobacco flavor component from being released from the tobacco molded body, it is desirable that the tobacco molded body do not include a binder.

**[0101]** The tobacco molded body may include a humectant in order to adjust moisture content. The humectant also serves as an aerosol generating agent. The humectant may be a polyhydric alcohol, and examples thereof include glycerine, propylene glycol, sorbitol, xylitol, and erythritol. The above polyhydric alcohols can be used alone or in combination of two or more. In the case where the tobacco molded body includes a humectant, the content of the humectant is commonly 5% to 15% by mass of the total mass of the tobacco molded body.

**[0102]** The tobacco molded body may optionally include a flavor material. The flavor material may be either solid or liquid. Examples of the flavor material include menthol, spearmint, peppermint, cocoa, carob, coriander, licorice, orange peel and rose hip, chamomile flower, lemon verbena, and a saccharide (e.g., fructose or sucrose). The content of the flavor material is commonly 0.5% to 45% by mass of the total mass of the tobacco molded body.

**[0103]** The “aerosol generating agent” is a source (i.e., liquid) that generates a vapor (i.e., gas) when a non-combustion-heating-type flavor inhalator including a dry tobacco filler is heated. The “aerosol generating agent” is a source (i.e., liquid) that generates a dispersion medium (i.e., gas) for aerosol (i.e., mainstream smoke) and does not include fine particles (e.g., particles of a tobacco flavor component) included in aerosol. That is, a tobacco flavor

component included in the dry tobacco material migrates into a vapor generated as a result of heating of the aerosol generating agent and an aerosol (i.e., mainstream smoke) is generated consequently. In the case where the tobacco material is a tobacco molded body, as described above, the aerosol generating agent may be incorporated into the tobacco molded body when the tobacco molded body is prepared or after the tobacco molded body has been prepared.

**[0104]** Examples of the aerosol generating agent include glycerine, propylene glycol, triacetin, 1,3-butanediol, and mixtures thereof. The aerosol generating agent is preferably a mixture of glycerine and propylene glycol. In the case where a mixture of glycerine and propylene glycol is used, the mass ratio between glycerine and propylene glycol is, for example, 80:20 to 97.5:2.5. The content of the aerosol generating agent in the untreated tobacco filler is, for example, 15% to 19% by mass of the amount of the untreated tobacco filler.

**[0105]** The dry tobacco filler may include an additional component, such as the flavor material described above, as needed.

**[0106]** In the present description, the “moisture content” in the dry tobacco filler and the “moisture content” in the untreated tobacco filler can be determined using GC-TCD in the following manner.

**[0107]** First, the weight of the dry tobacco filler is measured. Subsequently, a predetermined amount of methanol (Guaranteed Reagent or higher one) is added and sealing is performed hermetically. Then, shaking is performed for 40 minutes (200 rpm). The resulting mixture is left to stand over a night. After the mixture has been again shaken for 40 minutes (200 rpm), it is left to stand. The resulting supernatant is used as a solution that is to be analyzed.

**[0108]** The above solution is subjected to GC-TCD and the moisture content is determined using a calibration curve method. GC-TCD may be performed, for example, under the following conditions:

**[0109]** GC-TCD: “Gas Chromatograph 6890” produced by Hewlett Packard

**[0110]** Column: HP Polapack Q (packed column) Constant Flow mode 20.0 mL/min

**[0111]** Injection: 1.0  $\mu$ L

**[0112]** Inlet: EPC purge packed column inlet Heater: 230° C.

**[0113]** Gas: He Total flow: 21.1 mL/min

**[0114]** Oven: 160° C. (hold 4.5 min)→(60° C./min)→220° C. (hold 4.0 min)

**[0115]** Detector: TCD detector, Reference Gas (He), flow rate: 20 mL/min

**[0116]** Make up gas (He): 3.0 mL/min

**[0117]** Signal rate: 5 Hz

## 2. Method for Producing Dry Tobacco Filler

**[0118]** As described above, the dry tobacco filler can be produced by drying the untreated tobacco filler to an intended moisture content. As described above, the untreated tobacco filler includes a tobacco material and an aerosol generating agent and commonly has a moisture content of 10% to 15% by mass.

**[0119]** Specifically, the method for producing a dry tobacco filler includes drying a tobacco filler (i.e., an untreated tobacco filler) including a tobacco material and an

aerosol generating agent to prepare a dry tobacco filler having a moisture content of more than 5% by mass and 7.5% by mass or less.

**[0120]** The above drying treatment may be performed by drying the untreated tobacco filler directly. Alternatively, after a tobacco rod has been produced by wrapping the untreated tobacco filler with a wrapping paper, the tobacco rod may be dried. In another case, after a non-combustion-heating-type flavor inhalator has been produced by connecting the above tobacco rod and the filter to each other, the non-combustion-heating-type flavor inhalator may be dried. When the untreated tobacco filler is dried, part of the moisture contained in the tobacco filler can be removed substantially without removing the aerosol generating agent because of a high boiling point of the aerosol generating agent.

**[0121]** The drying treatment can be performed using any drying method with which a dry tobacco filler having the intended moisture content can be prepared. For example, the drying treatment can be performed using microwave heating. In the case where microwave heating is used, the moisture content in the tobacco filler can be adjusted by changing the amount of time during which heating is performed (FIG. 8). Microwave heating is typically performed with a microwave oven. In the case where a 500-Watt microwave oven is used, the amount of heating time that can be applied to 5 g of an untreated tobacco filler is, for example, 30 to 40 seconds (FIG. 8).

**[0122]** Alternatively, the drying treatment can be performed by placing the untreated tobacco filler under a hermetically sealed condition together with a desiccant. For example, the drying treatment can be performed at 15° C. to 25° C. for 10 to 15 days. Examples of the desiccant that can be used include silica gel. In the case where a desiccant is used, the moisture content in the tobacco filler can be adjusted by changing the amount of the desiccant used (FIG. 9). In the case where silica gel is used as a desiccant, for example, 2 to 4 g of silica gel may be used relative to 5 g of the untreated tobacco filler (FIG. 9). In another case, the drying treatment may be performed using hot-air drying or vacuum drying.

**[0123]** The drying treatment is preferably performed such that the surface temperature of the tobacco filler is 65° C. or less. The drying treatment is more preferably performed such that the surface temperature of the tobacco filler is normal temperature (i.e., 20° C.) to 65° C. If the surface temperature of the tobacco filler is excessively high, the content of the aerosol generating agent in the tobacco filler may be reduced. If the surface temperature of the tobacco filler is excessively high, furthermore, cell membranes and cell walls of the tobacco material may become damaged. This increases the likelihood of a tobacco flavor component being released from the tobacco material and may increase a sense of discomfort felt by the user of the flavor inhalator upon inhalation to an excessive level.

**[0124]** The surface temperature of the tobacco filler is a temperature measured with a thermographic camera “FLIR-C2” produced by FLIR System Inc.

**[0125]** In the present description, the term “tobacco filler” is used when a tobacco filler that has not been dried (i.e., untreated tobacco filler), a tobacco filler that is being dried, and a tobacco filler that has been dried are collectively referred to without distinction.

**[0126]** According to another aspect, a dry tobacco filler produced by the above-described method is provided.

**[0127]** The dry tobacco filler prepared by the above-described method is mixed with the above-described fibrous material and the resulting mixture is formed into a sheet for non-combustion-heating-type flavor inhalators. The sheet can be formed by a method known in the related art, such as the following method.

**[0128]** 1) Mixing an untreated tobacco filler with a fibrous material and forming the resulting mixture into a sheet by a common method

**[0129]** 2) Forming the dry tobacco filler into a powder or the like, mixing the powder with a fibrous material, and forming the resulting mixture into a sheet

### 3. Non-Combustion-Heating-Type Flavor Inhalator

**[0130]** The sheet formed of the dry tobacco filler described above can be incorporated into a non-combustion-heating-type flavor inhalator (hereinafter, also referred to simply as “flavor inhalator”). Specifically, according to another aspect, a non-combustion-heating-type flavor inhalator that includes a tobacco rod including a sheet formed of the dry tobacco filler described above and a wrapping paper wound around the periphery of the dry tobacco filler; a filter; and a tipping member with which the tobacco rod and the filter are connected to each other can be provided. Note that the tipping member is a member capable of serving as a tipping paper, which is commonly included in cigarettes (i.e., capable of connecting the tobacco rod to the filter). In addition to paper (i.e., tipping paper), sheets composed of various high-molecular-weight compound materials can be used as a tipping member.

**[0131]** In the present description, the non-combustion-heating-type flavor inhalator and a heating device are collectively referred to as “non-combustion-heating-type flavor inhalation system” or simply as “flavor inhalation system”. Specifically, according to another aspect, a non-combustion-heating-type flavor inhalation system that includes the “non-combustion-heating-type flavor inhalator” described above and a heating device (hereinafter, also referred to as “aerosol generation apparatus”) that heats the flavor inhalator to generate an aerosol can be provided.

**[0132]** A known example of the non-combustion-heating-type flavor inhalation system is an electric heating-type inhalation system that includes a flavor inhalator and a heating device that electrically heats the flavor inhalator (e.g., see WO96/32854 and WO2010/110226). An examples of the non-combustion-heating-type flavor inhalation system is described below with reference to FIG. 4, etc. FIG. 4 is a perspective view of an example of the non-combustion-heating-type flavor inhalation system. FIG. 5 is a diagram illustrating the internal structure of the aerosol generation apparatus.

**[0133]** As illustrated in FIG. 4, a flavor inhalation system **100** includes a flavor inhalator **1** that includes a sheet formed of the above-described dry tobacco filler, which includes a dry tobacco material and an aerosol generating agent, and an aerosol generation apparatus **120** that heats the flavor inhalator **1** in order to atomize the aerosol generating agent and cause a flavor component to be released from the dry tobacco material.

**[0134]** The flavor inhalator **1** is an exchangeable cartridge and has a pillar shape extending in one direction. The flavor inhalator **1** generates an aerosol including a flavor compo-

ment when the flavor inhalator **1** is heated while inserted in the aerosol generation apparatus **120**.

[0135] The dimension of the flavor inhalator **1** in the longitudinal direction, that is, the length of the flavor inhalator **1**, is preferably 40 to 90 mm, is more preferably 50 to 75 mm, and is further preferably 50 to 60 mm. The perimeter of the flavor inhalator **1** is preferably 15 to 25 mm, is more preferably 17 to 24 mm, and is further preferably 20 to 23 mm. In the flavor inhalator **1**, the tobacco-containing segment **2** may have a length of 20 mm, the paper tube part may have a length of 20 mm, the hollow plug may have a length of 8 mm, and the filter plug may have a length of 7 mm. The lengths of the above segments may be changed appropriately in accordance with manufacturability, required qualities, and the like.

[0136] The filler includes a sheet formed of a fibrous material and the above-described dry tobacco filler, which includes a dry tobacco material and an aerosol generating agent. The sheet is preferably formed of the above-described fibrous material and “dry tobacco filler” in consideration of the advantageous effects of the invention. However, the sheet may include a component other than the above components such that the advantageous effects of the invention are not impaired.

[0137] The aerosol generating agent generates a vapor when heated to a predetermined temperature. As described above, examples of the aerosol generating agent include glycerine, propylene glycol, triacetin, 1,3-butanediol, and mixtures thereof. As described above, the content of the aerosol generating agent in the untreated tobacco filler may be, for example, 15% to 19% by mass of the amount of the untreated tobacco filler.

[0138] The content of the filler in the flavor inhalator **1** is, for example, 200 to 400 mg and is preferably 250 to 320 mg in the case where the tobacco-containing segment **2** has a perimeter of 22 mm and a length of 20 mm.

[0139] As illustrated in FIG. 5, the aerosol generation apparatus **120** has an insertion hole **130** formed therein, into which the flavor inhalator **1** can be inserted. That is, the aerosol generation apparatus **120** includes an inner cylinder member **132** that defines the insertion hole **130**. The inner cylinder member **132** may be composed of, for example, a thermally conductive material, such as aluminum or a stainless steel (SUS).

[0140] The aerosol generation apparatus **120** may include a lid **140** with which the insertion hole **130** can be covered. The lid **140** is slidably arranged so as to allow switchover between the state where the lid **140** covers the insertion hole **130** and the state where the insertion hole **130** is exposed (see FIG. 4).

[0141] The aerosol generation apparatus **120** may have an airflow path **160** formed therein and communicated with the insertion hole **130**. One of the ends of the airflow path **160** is connected to the insertion hole **130**, while the other end of the airflow path **160** is communicated with the outside of the aerosol generation apparatus **120** (i.e., the outside air) at a position other than that of the insertion hole **130**.

[0142] The aerosol generation apparatus **120** may include a lid **170** that covers the end of the airflow path **160** at which the airflow path **160** is communicated with the outside air. The lid **170** allows switchover between the state where the lid **170** covers the end of the airflow path **160** at which the airflow path **160** is communicated with the outside air and the state where the above end is exposed.

[0143] Although the lid **170** covers the above end of the airflow path **160** in the drawing, the lid **170** does not hermetically block the airflow path **160**. In other words, although the lid **170** covers the airflow path **160**, it is arranged to be spaced away from the above end of the airflow path **160** and to allow the outside air to enter the airflow path **160** through the gap formed therebetween.

[0144] With the flavor inhalator **1** being inserted in the aerosol generation apparatus **120**, the user holds the inhalation port in the mouth and performs an inhalation action. Upon the inhalation action of the user, the outside air enters the airflow path **160**. The air that enters the airflow path **160** is introduced into the oral cavity of the user through the flavor inhalator **1** inserted in the insertion hole **130**.

[0145] The aerosol generation apparatus **120** may include a temperature sensor disposed inside the airflow path **160** or on the outside surface of the wall that defines the airflow path **160**. The temperature sensor may be a thermistor thermometer, a thermocouple, or the like. When the user inhales through the inhalation port of the flavor inhalator **1**, the temperature of the inside of the airflow path **160** or the temperature of the wall that defines the airflow path **160** is reduced due to the impacts of the air that flows inside the airflow path **160** in the direction from the lid **170** toward the heater **30** described below. The temperature sensor measures the temperature drop and thereby detects the inhalation action of the user.

[0146] The aerosol generation apparatus **120** includes a battery **B**, a control unit **20**, and a heater **30**. The battery **B** stores the electric power that is to be used in the aerosol generation apparatus **120**. The battery **B** may be a chargeable and dischargeable secondary battery. The battery **B** may be, for example, a lithium ion battery.

[0147] The heater **30** may be arranged around the inner cylinder member **132**. The space that accommodates the heater **30** and the space that accommodates the battery **B** may be separated from each other with a partition **180**. In such a case, the likelihood of the air heated by the heater **30** entering the space that accommodates the battery **B** can be reduced and, consequently, an increase in the temperature of the battery **B** can be limited.

[0148] The heater **30** preferably has a hollow cylindrical shape that enables the outer circumference of the columnar flavor inhalator **1** to be heated. The heater **30** is, for example, a film heater. The film heater may include a pair of film-like substrates and a resistance heating element interposed between the substrates. The film-like substrates are preferably composed of a material having excellent heat resistance and an excellent electric insulation property and is typically composed of polyimide. The resistance heating element is preferably composed of one or more metal materials, such as copper, a nickel alloy, a chromium alloy, a stainless steel, and platinum rhodium, and may be formed of, for example, a stainless steel substrate. The connector of the resistance heating element and the lead of the connector may be plated with copper in order to connect the resistance heating element to a power source through a flexible print circuit (FPC).

[0149] It is preferable to arrange a heat-shrinkable tube on the outer periphery of the heater **30**. The heat-shrinkable tube is a tube that shrinks in the radial direction when heated and is composed of a thermoplastic elastomer or the like. As a result of shrinkage of the heat-shrinkable tube, the heater **30** is pressed against the inner cylinder member **132**. This

increases the adhesion between the heater **30** and the inner cylinder member **132** and consequently enhances the transfer of heat from the heater **30** to the flavor inhalator **1** through the inner cylinder member **132**.

**[0150]** The aerosol generation apparatus **120** may include a tubular heat insulating material arranged outside the heater **30** in the radial direction and preferably arranged outside the heat-shrinkable tube. The heat insulating material blocks the heat generated by the heater **30** and thereby may reduce the possibility of the temperature of the outside surface of the casing of the aerosol generation apparatus **120** being increased to an excessive degree. The heat insulating material may be made of an aerogel, such as a silica aerogel, a carbon aerogel, or an alumina aerogel. The aerogel used as a heat insulating material may be typically a silica aerogel, which has a high heat-insulation property and relatively low production costs. The heat insulating material may be a fiber-based heat insulating material, such as a glass wool or a rock wool, or a foam-based heat insulating material, such as a urethane foam or a phenolic foam. In another case, the heat insulating material may be a vacuum heat insulator.

**[0151]** An outer cylinder member **134** is disposed outside the heat insulating material. The heat insulating material may be interposed between the inner cylinder member **132**, which faces the flavor inhalator **1**, and the outer cylinder member **134**. The outer cylinder member **134** may be composed of, for example, a thermally conductive material, such as aluminum or a stainless steel (SUS). The heat insulating material is preferably disposed in an enclosed space.

**[0152]** The control unit **20** may include a circuit board, a central processing unit (CPU), a memory, and the like. The aerosol generation apparatus **120** may include a notifier that notifies various types of information to the user under the control by the control unit **20**. The notifier may be, for example, a light-emitting device, such as a light-emitting diode (LED), a vibrating device, or a combination thereof.

**[0153]** Upon detecting a startup request from the user, the control unit **20** starts feeding electric power from the battery **B** to the heater **30**. The startup request from the user can be made by, for example, the user pressing a button, operating a slider switch, or performing an inhalation action. The startup request from the user may be made by pressing a push button **150**. Specifically, the startup request from the user may be made by pressing the push button **150** while the lid **140** is opened. In another case, the startup request from the user may be made upon detecting the inhalation action of the user. The inhalation action of the user can be detected using, for example, the above-described temperature sensor.

#### 4. Packaged Product

**[0154]** As described above, the “dry tobacco filler” can be produced by placing an untreated tobacco filler together with a desiccant under a hermetically sealed condition (see <2. Method for Producing Dry Tobacco Filler>). In the above case, after a “dry tobacco filler” having the intended moisture content has been produced, a fibrous material is added to the dry tobacco filler and the resulting mixture may be formed into a sheet and a flavor inhalator including the sheet may be placed on the market as a commodity. In another case, before the moisture content in an untreated tobacco filler placed under a hermetically sealed condition together with a fibrous material and a desiccant reaches the intended level, the tobacco filler including the fibrous material may be

formed into a sheet and a flavor inhalator including the sheet may be placed on the market as a commodity. In the latter case, the tobacco filler becomes dried while the flavor inhalator including the sheet formed of the tobacco filler is placed on the market as a commodity and, consequently, the moisture content in the sheet reaches the intended level.

**[0155]** That is, according to another aspect, a packaged product including a package; at least one non-combustion-heating-type flavor inhalator that is accommodated in the package and that includes a sheet composed of a fibrous material and a tobacco filler including a tobacco material and an aerosol generating agent; and a desiccant incorporated in the package in an amount necessary for the moisture content in the tobacco filler reaching an equilibrium moisture content of more than 5% by mass and 7.5% by mass or less, wherein the moisture content in the tobacco filler reaches the equilibrium moisture content of more than 5% by mass and 7.5% by mass or less in the package, can be provided. The non-combustion-heating-type flavor inhalator is preferably accommodated in the package under a hermetically sealed condition.

**[0156]** The “package” may be a package that is used in the technical field as a package for tobacco products, such as cigarettes, and that has a sealing property. Examples of the package include a cigarette pack commonly used as a cigarette package, that is, specifically, a cigarette pack constituted by an outer pack including a paper box with a hinge lid and an inner pack including an inner wrap paper with which a bundle of cigarettes is wrapped;

**[0157]** a can container including a can container main body, a can lid, and a metal inner lid that covers the opening of the can container main body to cut off the internal space of the can container main body from the outside air;

**[0158]** a PTP package (press through pack) used for packaging medicines, that is, specifically, a package that accommodates the contents between a plastic portion having accommodating spaces and a tabular aluminum portion;

**[0159]** an SP package (strip package) used for packaging medicines, that is, specifically, a package that accommodates the contents between two thermal adhesive film sheets the peripheries of which are bonded to each other by heat sealing; and a plastic bag having a sealing property.

**[0160]** FIG. 6, etc. illustrate an example of the cigarette pack. FIG. 6 illustrates the state where the cigarette pack is closed. FIG. 7 illustrates the state where the cigarette pack is opened. A cigarette pack **P4** includes a box **P5** and a lid **P6**. The box **P5** includes a box main body **P5a** and an inner frame **P5b**. The box **P5** has an opening formed at the upper end. The lid **P6** is connected to the rear edge of the open end of the box **P5** with an automatic hinge **P7** being interposed therebetween. The lid **P6** is capable of moving rotationally around the automatic hinge **P7** and enables the open end of the box **P5** to be opened and closed. As illustrated in FIG. 7, the inner frame **P5b** is partially inserted into the box main body **P5a** and protruded at the opening of the box main body **P5a** to form the open end of the box **P5**. The lid **P6** is arranged to cover the opening end of the box **P5** (i.e., the protruded portion of the inner frame **P5b**) and enables the open end of the box **P5** to be closed. The opening of the lid **P6** and the opening of the box main body **P5a** conform to each other. The cigarette pack commonly further includes an

inner pack (not illustrated in the drawing) disposed inside the box P5 and formed of an inner wrap paper with which a bundle of cigarettes is wrapped. The cigarette pack commonly further includes a film packing material (not illustrated in the drawing) that is disposed outside the box P5 and includes a tear tape.

**[0161]** The “non-combustion-heating-type flavor inhalator” that is to be accommodated in the package is a flavor inhalator that includes the “untreated tobacco filler T3a” illustrated in FIG. 3. The “non-combustion-heating-type flavor inhalator” that is to be accommodated in the package may be the one commercially available as a tobacco stick for non-combustion-heating-type flavor inhalation systems or a flavor inhalator produced using a tobacco filler (e.g., having a moisture content of 10% to 15% by mass) prepared for existing non-combustion-heating-type flavor inhalation systems.

**[0162]** The number of the non-combustion-heating-type flavor inhalators that are to be accommodated in the package is at least one and, for example, 40 or less. In the case where the package is a cigarette pack, the number of the non-combustion-heating-type flavor inhalators that are to be accommodated in the package is commonly 10 to 20 and, for example, 20.

**[0163]** The “desiccant” may be a desiccant commonly used as a desiccant for foods or medicines and is, for example, a silica gel. The desiccant is incorporated into the package in an amount necessary for the moisture content in the tobacco filler reaching an equilibrium moisture content of more than 5% by mass and 7.5% by mass or less. The moisture content in the tobacco filler can be adjusted by changing the amount of desiccant. In the case where the desiccant is a silica gel, for preparing a dry tobacco filler having an equilibrium moisture content of more than 5% by mass and 7.5% by mass or less using an untreated tobacco filler having a moisture content of about 14% by mass, for example, 2 to 4 g of silica gel may be used relative to 5 g of the tobacco filler.

**[0164]** In the above packaged product, the moisture content in the sheet formed of the fibrous material and the tobacco filler varies with time. Specifically, immediately after the non-combustion-heating-type flavor inhalator is charged into the package, the moisture content in the sheet is substantially the same as that in the sheet formed of the fibrous material and the tobacco filler that has not been dried; for example, the moisture content in the tobacco filler included in the sheet is 10% to 15% by mass. Subsequently, with a lapse of time since the non-combustion-heating-type flavor inhalator is charged into the package, the sheet becomes gradually dried due to the action of the desiccant and the moisture content in the sheet is reduced accordingly. Finally, the moisture content in the tobacco filler included in the sheet reaches an equilibrium moisture content of more than 5% by mass and 7.5% by mass or less, preferably 5.1% to 7.5% by mass, and more preferably 5.5% to 7.0% by mass.

**[0165]** Although the tobacco filler included in the above package product changes with time, a “tobacco filler that has not been dried”, a “tobacco filler that is being dried”, and a “tobacco filler that has been dried” are collectively referred to as “tobacco filler”.

## 5. Advantageous Effects

**[0166]** When the moisture content in the tobacco filler is reduced to 7.5% by mass or less in accordance with the present invention, in a non-combustion-heating-type flavor inhalator including a sheet formed of the tobacco filler, the temperature of the mainstream smoke and the surface temperature of the tipping paper can be reduced. This reduces the likelihood of the user sensing the heat of the aerosol and the heat of the mouthpiece end of the article upon inhalation.

**[0167]** Furthermore, when the lower limit for the moisture content in the tobacco filler is set to more than 5% by mass, that is, for example, 5.1% by mass or more, in accordance with the present invention, the contents of the aerosol generating agent and the tobacco flavor source (e.g., nicotine) in the tobacco filler can be maintained without loss even after the drying step. In the present description, the property of maintaining the aerosol generating agent and the tobacco flavor source in a consistent manner even after drying without the contents of the aerosol generating agent and the tobacco flavor source (e.g., nicotine) being reduced while the tobacco filler is dried is referred to as “quality stability of the tobacco filler”. The “quality stability of the tobacco filler” is one of the important properties of the flavor inhalator because this property is closely related to transferring a tobacco flavor source to a vapor generated as a result of heating of the aerosol generating agent and delivering it to the user.

**[0168]** As described above, when a sheet formed of a tobacco filler the moisture content of which has been reduced to more than 5% by mass and 7.5% by mass or less and preferably 5.1% to 7.5% by mass is used as a filler, a non-combustion-heating-type flavor inhalator that reduces the likelihood of the user sensing the heat of an aerosol and the heat of the mouthpiece end of the article upon inhalation and that is excellent in terms of the quality stability of the tobacco filler can be provided.

### [Second Aspect]

**[0169]** A tobacco sheet according to this aspect is formed of a fibrous material and a dry tobacco filler that includes a dry tobacco material and an aerosol generating agent the content of which is less than 20% by mass, the dry tobacco filler having a moisture content of 3% to 5% by mass. The content of the dry tobacco filler in the sheet is as described in First Aspect.

#### 1. Dry Tobacco Filler

**[0170]** According to an aspect, a sheet formed of a fibrous material and a dry tobacco filler that includes a dry tobacco material and an aerosol generating agent the content of which is less than 20% by mass, the dry tobacco filler having a moisture content of 3% to 5% by mass, is provided. The sheet may be included in the non-combustion-heating-type flavor inhalator. The moisture content in the “dry tobacco filler” is 3.0% to 5.0% by mass, is preferably 3.5% to 5.0% by mass, and is more preferably 4.0% to 5.0% by mass. In the present description, the “moisture content in the dry tobacco filler” is the proportion (% by mass) of the mass of moisture to the total mass of the dry tobacco filler. Details of the dry tobacco filler are the same as those described in First Aspect, except moisture content.

**[0171]** Examples of the aerosol generating agent include glycerine, propylene glycol, triacetin, 1,3-butanediol, and

mixtures thereof. The aerosol generating agent is preferably a mixture of glycerine and propylene glycol. In the case where a mixture of glycerine and propylene glycol is used, the mass ratio between glycerine and propylene glycol is, for example, 80:20 to 97.5:2.5.

**[0172]** The content of the aerosol generating agent is less than 20% by mass of the total mass of the dry tobacco filler. The content of the aerosol generating agent in the dry tobacco filler is less than 20% by mass, is preferably 19% by mass or less, and is more preferably 15% to 19% by mass of the total mass of the dry tobacco filler.

**[0173]** In the case where the aerosol generating agent is a mixture of glycerine and propylene glycol, the content of the propylene glycol is preferably 3% by mass or less of the total mass of the dry tobacco filler. The content of the propylene glycol in the dry tobacco filler is preferably 3% by mass or less and is more preferably 1% to 3% by mass.

**[0174]** In the present description, the “content of the aerosol generating agent” in the dry tobacco filler can be determined in the following manner: the dry tobacco filler is added to a predetermined amount of ethanol (10 to 100 mL, which is adjusted appropriately in accordance with the amount of dry tobacco filler) in order to perform extraction, and the content of the aerosol generating agent (e.g., glycerine and propylene glycol) can be measured using GC-MS.

## 2. Method for Producing Dry Tobacco Filler

**[0175]** The method for producing a dry tobacco filler in this aspect is the same as that described in First Aspect. Note that, in this aspect, the drying treatment is preferably performed in the following manner.

**[0176]** Specifically, the method for producing a dry tobacco filler includes drying a tobacco filler including a tobacco material and an aerosol generating agent such that the surface temperature of the tobacco filler is 90° C. or less to prepare a dry tobacco filler having a moisture content of 3% to 5% by mass.

**[0177]** The above drying treatment may be performed by drying the untreated tobacco filler directly. Alternatively, after a tobacco rod has been produced by wrapping the untreated tobacco filler with a wrapping paper, the tobacco rod may be dried. In another case, after a non-combustion-heating-type flavor inhalator has been produced by connecting the above tobacco rod and the filter to each other, the non-combustion-heating-type flavor inhalator may be dried. When the untreated tobacco filler is dried, part of the moisture contained in the tobacco filler can be removed substantially without removing the aerosol generating agent because of a high boiling point of the aerosol generating agent.

**[0178]** The drying treatment can be performed using any drying method with which a dry tobacco filler having the intended moisture content can be prepared. For example, the drying treatment may be performed at room temperature and a humidity of 30% or less. The room temperature is typically a temperature of 5° C. to 35° C. The drying treatment is preferably performed at 5° C. to 35° C. and is more preferably performed at 15° C. to 25° C. The drying treatment is preferably performed at a humidity of 10% to 30% and is more preferably performed at a humidity of 15% to 25%.

**[0179]** Alternatively, the drying treatment can be performed using microwave heating. In the case where microwave heating is used, the moisture content in the tobacco

filler can be adjusted by changing the amount of time during which heating is performed (FIG. 14). Microwave heating is typically performed with a microwave oven. In the case where a 500-Watt microwave oven is used, the amount of heating time that can be applied to 5.0 g of an untreated tobacco filler is, for example, 40 to 60 seconds (FIG. 14).

**[0180]** In another case, the drying treatment may be performed by placing the untreated tobacco filler in the presence of a desiccant. Specifically, the drying treatment can be performed by placing the untreated tobacco filler under a hermetically sealed condition together with a desiccant. For example, the drying treatment can be performed at 15° C. to 25° C. for 10 to 15 days. Examples of the desiccant that can be used include silica gel. In the case where a desiccant is used, the moisture content in the tobacco filler can be adjusted by changing the amount of the desiccant used (FIG. 15). In the case where silica gel is used as a desiccant, for example, 4 to 10 g of silica gel may be used relative to 5.0 g of the untreated tobacco filler (FIG. 15). In another case, the drying treatment may be performed using hot-air drying or vacuum drying.

**[0181]** The drying treatment may be performed such that the surface temperature of the tobacco filler is 90° C. or less. The drying treatment is preferably performed such that the surface temperature of the tobacco filler is normal temperature (i.e., 20° C.) to 90° C. The drying treatment is more preferably performed such that the surface temperature of the tobacco filler is 65° C. or less. The drying treatment is further preferably performed such that the surface temperature of the tobacco filler is normal temperature (i.e., 20° C.) to 65° C. If the surface temperature of the tobacco filler is excessively high, the content of the aerosol generating agent in the tobacco filler may be reduced. If the surface temperature of the tobacco filler is excessively high, furthermore, cell membranes and cell walls of the tobacco material may become damaged. This increases the likelihood of a tobacco flavor component being released from the tobacco material and may increase an irritation felt by the user of the flavor inhalator upon inhalation to an excessive level.

**[0182]** The surface temperature of the tobacco filler is a temperature measured with a thermographic camera “FLIR-C2” produced by FLIR System Inc.

**[0183]** A dry tobacco filler prepared in the above-described manner is mixed with the above-described fibrous material, and the resulting mixture can be formed into a sheet that is to be included in the non-combustion-heating-type flavor inhalator. The method for forming the sheet is the same as that described in First Aspect.

## 3. Non-Combustion-Heating-Type Flavor Inhalator

**[0184]** The non-combustion-heating-type flavor inhalator and non-combustion-heating-type flavor inhalation system according to this aspect are the same as those described in First Aspect.

## 4. Packaged Product

**[0185]** The packaged product according to this aspect is the same as that described in First Aspect, except that the moisture content in the tobacco filler is adjusted to reach an equilibrium moisture content of 3% to 5% by mass in the package.

**[0186]** In this aspect, the “desiccant” may be a desiccant commonly used as a desiccant for foods or medicines and is,

for example, a silica gel. The desiccant is incorporated into the package in an amount necessary for the moisture content in the tobacco filler reaching an equilibrium moisture content of 3% to 5% by mass. The moisture content in the tobacco filler can be adjusted by changing the amount of desiccant. In the case where the desiccant is a silica gel, for preparing a dry tobacco filler having an equilibrium moisture content of 3 to 5% by mass using an untreated tobacco filler having a moisture content of about 14% by mass, for example, 4 to 10 g of silica gel may be used relative to 5.0 g of the tobacco filler.

[0187] In the above packaged product, the moisture content in the sheet formed of the fibrous material and the tobacco filler varies with time. Specifically, immediately after the non-combustion-heating-type flavor inhalator is charged into the package, the moisture content in the sheet is substantially the same as that in the sheet formed of the fibrous material and the tobacco filler that has not been dried; for example, the moisture content in the tobacco filler included in the sheet is 10% to 15% by mass. Subsequently, with a lapse of time since the non-combustion-heating-type flavor inhalator is charged into the package, the sheet becomes gradually dried due to the action of the desiccant and the moisture content in the sheet is reduced accordingly. Finally, the moisture content in the tobacco filler included in the sheet reaches an equilibrium moisture content of 3.0% to 5.0% by mass, preferably 3.5% to 5.0% by mass, and more preferably 4.0% to 5.0% by mass.

#### 5. Advantageous Effects

[0188] When the moisture content in the tobacco filler is reduced to 3% to 5% by mass in accordance with the present invention, in a non-combustion-heating-type flavor inhalator including a sheet formed of the tobacco filler, the temperature of the mainstream smoke and the surface temperature of the tipping paper can be reduced. This reduces the likelihood of the user sensing the heat of the aerosol and the heat of the mouthpiece end of the article upon inhalation.

[0189] Furthermore, when the moisture content in the tobacco filler is reduced to 3% to 5% by mass in accordance with the present invention, the amount of the tobacco flavor source (e.g., nicotine) included in the tobacco mainstream smoke and the amount of aerosol (i.e., the amount of smoke) can be increased. This enhances the feel of smoking.

[0190] In addition, when the content of the aerosol generating agent in the tobacco filler is set to less than 20% by mass in accordance with the present invention, the following advantageous effects are produced. While the vaporization of the aerosol included in the tobacco filler involves the loss of heat due to vaporization, when the content of the aerosol generating agent in the tobacco filler falls within the above range, the loss of heat due to the vaporization of the aerosol generating agent can be reduced. This limits a reduction in the efficiency with which the tobacco filler is heated. Consequently, in the case where the content of the aerosol generating agent in the tobacco filler falls within the above range, the component (e.g., glycerine or nicotine) included in the tobacco filler is likely to serve as a dispersion medium for aerosol (i.e., mainstream smoke) or likely to migrate to a dispersion medium for aerosol and the feel of smoking may be enhanced accordingly, compared with the case where the above content exceeds the above range.

[0191] As described above, when a sheet formed of a tobacco filler the moisture content of which has been

reduced to 3% to 5% by mass and the content of the aerosol generating agent in which is less than 20% by mass is used as a filler, a non-combustion-heating-type flavor inhalator that reduces the likelihood of the user sensing the heat of an aerosol and the heat of the mouthpiece end of the article upon inhalation and that is improved in terms of the feel of smoking can be provided.

#### EXAMPLES

[0192] Specific examples of the above-described embodiments are described below. The present invention is not limited to Examples below.

##### Example 1

[0193] Tobacco lamina (i.e., leaf tobacco) was dry-pulverized with Hosokawa Micron ACM to form a tobacco powder. The cumulative 90% particle size (D90) of the tobacco powder, which was determined using a volume-basis particle size distribution measured with "Mastersizer" (product name, produced by Malvern Panalytical, a division of Spectris) by dry laser diffraction, was 200  $\mu\text{m}$ .

[0194] A tobacco sheet was prepared by a rolling method using the above tobacco powder as a tobacco raw material. Specifically, 77 parts by mass of the tobacco raw material, 12 parts by mass of glycerine used as an aerosol generating agent, 1 part by mass of carboxymethyl cellulose used as a shaping agent, and 10 parts by mass of a fibrous pulp (dry fibrillated article of a pulp produced by Canfor Corporation) used as a fibrous material, were mixed with one another, and the resulting mixture was kneaded with an extrusion molding machine. The kneaded material was formed into a sheet-like shape with two pairs of metal rollers. The sheet was dried with a convection oven at 80° C. to form a tobacco sheet. The tobacco sheet was shredded to a size of 0.8 mm $\times$ 9.5 mm with a shredder.

[0195] The bulkiness of the shredded tobacco sheet was determined. Specifically, the shredded tobacco sheet was stored in a conditioning room at 22° C. and 60% for 48 hours, and the bulkiness of the tobacco sheet was measured with "DD-60A" (product name, produced by Burghart Messtechnik GmbH). In the analysis, specifically, 15 g of the shredded tobacco sheet was charged into a cylindrical container having an inside diameter of 60 mm and compressed at a load of 3 kg for 30 seconds, and the volumetric capacity of the tobacco sheet was measured subsequently. Table 1 lists the results. In Table 1, bulkiness is expressed in terms of the rate (%) of increase in bulkiness with respect to a reference value, which is the bulkiness determined in Comparative Example 1 below.

##### Comparative Example 1

[0196] A tobacco powder was prepared as in Example 1. A tobacco sheet was prepared by a rolling method using the above tobacco powder as a tobacco raw material. Specifically, 87 parts by mass of the tobacco raw material, 12 parts by mass of glycerine used as an aerosol generating agent, and 1 part by mass of carboxymethyl cellulose used as a shaping agent were mixed with one another, and the resulting mixture was kneaded with an extrusion molding machine. The kneaded material was formed into a sheet-like shape with two pairs of metal rollers. The sheet was dried with a convection oven at 80° C. to form a tobacco sheet. The tobacco sheet was shredded to a size of 0.8 mm $\times$ 9.5 mm

with a shredder. The bulkiness of the shredded tobacco sheet was determined as in Example 1. Table 1 lists the results.

TABLE 1

	Increase in bulkiness (%)
Example 1	33
Comparative Example 1	—

[0197] As described in Table 1, the tobacco sheet prepared in Example 1, which is the tobacco sheet according to the above-described embodiment, was improved in terms of bulkiness compared with the tobacco sheet prepared in Comparative Example 1, which did not include the fibrous material. In Example 1, where the tobacco sheet was prepared by a rolling method, bulkiness was enhanced even in the case where a tobacco sheet was prepared using a casting method.

[0198] The first aspect is described below with reference to Reference Example A.

#### [Reference Example A1] Moisture Content in Tobacco Filler

##### 1-1. Preparation of Flavor Inhalator

[0199] A tobacco stick for Ploom S produced by Japan Tobacco Inc. (product name: “MEVIUS REGULAR for Ploom S”) was subjected to any one of (A) microwave drying and (B) silica gel drying in order to reduce the moisture content in the tobacco filler included in the tobacco stick. The tobacco stick for Ploom S had the structure illustrated in FIG. 1.

[0200] The tobacco stick that had not been subjected to the drying treatment included 0.25 g of a tobacco filler (i.e., a mixture of a tobacco molded body and an aerosol generating agent) per stick. The tobacco filler had a moisture content of 13.69% by mass. The content of the aerosol generating agent in the tobacco filler was 15.60% by mass of the amount of the tobacco filler. The aerosol generating agent was a mixture of glycerine and propylene glycol. The mass ratio between glycerine and propylene glycol was 93.48:6.52.

[0201] As a control, a tobacco stick for Ploom S produced by Japan Tobacco Inc. (product name: “MEVIUS REGULAR for Ploom S”) was conditioned in a conditioning room at 22° C. and 60% for about 48 to 72 hours.

##### (A) Microwave Drying

[0202] A commercial microwave oven (“DR-D219W5 (2014)”) produced by Twinbird Corporation, 50 Hz) was used at 500 W, and 20 tobacco sticks (tobacco filler: 5.0 g in total) were heated in the microwave oven for a predetermined amount of time. The amount of heating time was 20, 40, 60, 80, or 100 seconds. After heating, 20 tobacco sticks were charged into a polypropylene (PP) zipper bag together and hermetically packed with an aluminum pouch bag. Hereby, a flavor inhalator was prepared. Immediately after the preparation of the flavor inhalator, the moisture content in the tobacco filler was measured.

##### (B) Silica Gel Drying

[0203] The silica gel used was a commercial silica gel for food drying (“HD1g (Blue)”) produced by Toyotakako Co.,

Ltd.). Into a polypropylene (PP) zipper bag, 20 tobacco sticks (tobacco filler: 5.0 g in total) and a predetermined amount of a silica gel were charged together, and they were hermetically packed with an aluminum pouch bag and left to stand for three weeks. The drying treatment was performed at room temperature (20° C.). The amount of the silica gel was 2, 4, 6, 8, or 10 g. Hereby, a flavor inhalator was prepared. Immediately after the preparation of the flavor inhalator, the moisture content in the tobacco filler was measured.

##### 1-2. Analysis of Moisture Content in Dry Tobacco Filler

[0204] A tobacco filler was taken from each of the flavor inhalator prepared above and the flavor inhalator used as a control, and the moisture contents in the tobacco fillers (% by mass) were measured using GCTCD in the above-described manner.

##### 1-3. Results

[0205] FIG. 8 illustrates the relationship between the amount of time during which heating was performed with the microwave oven and the moisture content in the tobacco filler and the relationship between the amount of time during which heating was performed with the microwave oven and the surface temperature of the tobacco filler. FIG. 9 illustrates the relationship between the amount of silica gel and the moisture content in the tobacco filler.

[0206] The results illustrated in FIG. 8 show the following facts. When the amount of time during which heating was performed with the microwave oven was increased, the moisture content in the tobacco filler was reduced. When the amount of time during which heating was performed with the microwave oven was increased, the surface temperature of the tobacco filler was increased. When 20 tobacco sticks (tobacco filler: 5.0 g in total) were heated with a 500-watt microwave oven for 30 to 40 seconds, a dry tobacco filler having a moisture content of more than 5% by mass and 7.5% by mass or less could be prepared.

[0207] The results illustrated in FIG. 9 show the following facts. When the amount of the silica gel used was increased, the moisture content in the tobacco filler was reduced. When 2 to 4 g of silica gel was used relative to 20 tobacco sticks (tobacco filler: 5.0 g in total), a dry tobacco filler having a moisture content of more than 5% by mass and 7.5% by mass or less could be prepared.

[0208] The above results confirm that a dry tobacco filler having the intended moisture content can be prepared by adjusting the amount of heating time and the amount of the desiccant used and thereby changing the degree to which drying is performed.

#### [Reference Example A2] Mainstream Smoke Temperatures and Tip Temperature

##### 2-1. Analysis of Mainstream Smoke Temperatures and Tip Temperature

[0209] The flavor inhalator prepared in Reference Example A1 and the flavor inhalator used as a control were heated using a heating device for Ploom S (produced by Japan Tobacco Inc.). The heating device had the structure illustrated in FIG. 5. After heating, the flavor inhalators were inhaled using an automatic inhalator.

**[0210]** After inhalation, the temperature of the mainstream smoke and the surface temperature of the mouthpiece end of the flavor inhalator (hereinafter, this surface temperature is referred to as “tip temperature”) were analyzed.

(Mainstream Smoke Temperature)

**[0211]** A thermocouple (product name: produced by TOA Electric Inc., model No. TI-SP-K) was disposed at a position 7 mm away from the mouthpiece end of the flavor inhalator toward the downstream, and the temperature of the mainstream smoke was measured at intervals of 0.1 seconds. The maximum value measured during the measurement period was determined as “mainstream smoke temperature”.

(Tip Temperature)

**[0212]** A thermocouple (produced by TOA Electric Inc., model No. TI-SP-K) was disposed on the surface of the tipping paper at a position 5 mm away from the mouthpiece end of the flavor inhalator toward the upstream, and the temperature of the mainstream smoke was measured at intervals of 0.1 seconds. The maximum value measured during the measurement period was determined as “tip temperature”.

## 2-2. Results

**[0213]** FIG. 10 illustrates the relationship between the moisture content in the tobacco filler and the temperature of the mainstream smoke and the relationship between the moisture content in the tobacco filler and the tip temperature.

**[0214]** The results illustrated in FIG. 10 show the following facts. Regardless of whether microwave drying or silica gel drying was performed, when the moisture content in the tobacco filler was reduced, the temperature of the mainstream smoke could be reduced accordingly. Moreover, regardless of whether microwave drying or silica gel drying was performed, when the moisture content in the tobacco filler was reduced, the tip temperature could be reduced accordingly.

**[0215]** The above results confirm that, when a tobacco filler having a low moisture content is included in a flavor inhalator, the user is unlikely to sense the heat of the aerosol or the heat of the mouthpiece end of the article upon inhalation. It is also confirmed that, for reducing the mainstream smoke temperature and the tip temperature to sufficient degrees, the moisture content in the tobacco filler is preferably 7.5% by mass or less and is more preferably 7.0% by mass or less.

[Reference Example A3] Contents of Nicotine, Glycerine, and Propylene Glycol in Tobacco Filler

### 3-1. Analysis of Contents of Nicotine, Glycerine, and Propylene Glycol in Tobacco Filler

**[0216]** The contents of nicotine, glycerine, and propylene glycol in the tobacco filler included in each of the flavor inhalator prepared in Reference Example A1 and the flavor inhalator used as a control were measured.

**[0217]** The tobacco filler was taken from each of the above flavor inhalators, and the contents of nicotine, glycerine, and propylene glycol in the tobacco filler were determined in the following manner. Specifically, the tobacco filler was subjected to extraction with a predetermined amount of ethanol (10 to 100 mL, which was adjusted appropriately in accor-

dance with the amount of the tobacco filler), and the contents of the above components were measured using GC-MS.

## 3-2. Results

**[0218]** FIG. 11 illustrates the relationship between the moisture content in the tobacco filler and the content of nicotine in the tobacco filler. FIG. 12 illustrates the relationship between the moisture content in the tobacco filler and the content of glycerine in the tobacco filler. FIG. 13 illustrates the relationship between the moisture content in the tobacco filler and the content of propylene glycol in the tobacco filler.

**[0219]** The results illustrated in the above drawings show the following facts. Regardless of whether microwave drying or silica gel drying was performed, the content of nicotine in the tobacco filler did not change when the moisture content in the tobacco filler was reduced. Similarly, regardless of whether microwave drying or silica gel drying was performed, the content of glycerine in the tobacco filler did not change when the moisture content in the tobacco filler was reduced.

**[0220]** On the other hand, in the case where microwave drying was performed, the content of propylene glycol in the tobacco filler was sharply reduced when the moisture content in the tobacco filler was 5% by mass or less. In the case where silica gel drying was performed, the content of propylene glycol in the tobacco filler was gradually reduced with the reduction in the moisture content in the tobacco filler. This confirms that, for drying the tobacco filler while maintaining the content of propylene glycol (i.e., aerosol generating agent) in the tobacco filler, the moisture content in the tobacco filler is preferably more than 5% by mass and is more preferably 5.1% by mass or more.

**[0221]** Moreover, the results illustrated in FIG. 8 show that, in the case where microwave drying is performed, the surface temperature of the tobacco filler is increased to about 65° C. when the moisture content in the tobacco filler is reduced to about 5% by mass. Accordingly, it is confirmed that, for drying the tobacco filler while maintaining the content of propylene glycol (i.e., aerosol generating agent) in the tobacco filler, the tobacco filler is preferably dried such that the surface temperature of the tobacco filler is 65° C. or less.

**[0222]** The second aspect is described below with reference to Reference Example B.

[Reference Example B1] Moisture Content in Tobacco Filler

### 1-1. Preparation of Flavor Inhalator

**[0223]** A tobacco stick for Ploom S produced by Japan Tobacco Inc. (product name: “MEVIUS REGULAR for Ploom S”) was subjected to any one of (A) microwave drying and (B) silica gel drying in order to reduce the moisture content in the tobacco filler included in the tobacco stick. The tobacco stick for Ploom S had the structure illustrated in FIG. 1.

**[0224]** The tobacco stick that had not been subjected to the drying treatment included 0.25 g of a tobacco filler (i.e., a mixture of a tobacco molded body and an aerosol generating agent) per stick. The tobacco filler had a moisture content of 13.69% by mass. The content of the aerosol generating agent in the tobacco filler was 15.60% by mass of the amount of

the tobacco filler. The aerosol generating agent was a mixture of glycerine and propylene glycol. The mass ratio between glycerine and propylene glycol was 93.48:6.52.

[0225] As a control, a tobacco stick for Ploom S produced by Japan Tobacco Inc. (product name: “MEVIUS REGULAR for Ploom S”) was conditioned in a conditioning room at 22° C. and 60% for about 48 to 72 hours.

#### (A) Microwave Drying

[0226] A commercial microwave oven (“DR-D219W5 (2014)”) produced by Twinbird Corporation, 50 Hz) was used at 500 W, and 20 tobacco sticks (tobacco filler: 5.0 g in total) were heated in the microwave oven for a predetermined amount of time. The amount of heating time was 20, 40, 60, 80, or 100 seconds. After heating, 20 tobacco sticks were charged into a polypropylene (PP) zipper bag together and hermetically packed with an aluminum pouch bag. Hereby, a flavor inhalator was prepared. Immediately after the preparation of the flavor inhalator, the moisture content in the tobacco filler was measured.

#### (B) Silica Gel Drying

[0227] The silica gel used was a commercial silica gel for food drying (“HD1g (Blue)”) produced by Toyotakako Co., Ltd.). Into a polypropylene (PP) zipper bag, 20 tobacco sticks (tobacco filler: 5.0 g in total) and a predetermined amount of a silica gel were charged together, and they were hermetically packed with an aluminum pouch bag and left to stand for three weeks. The drying treatment was performed at room temperature (20° C.). The amount of the silica gel was 2, 4, 6, 8, or 10 g. Hereby, a flavor inhalator was prepared. Immediately after the preparation of the flavor inhalator, the moisture content in the tobacco filler was measured.

#### 1-2. Analysis of Moisture Content in Dry Tobacco Filler and Content of Aerosol Generating Agent

[0228] A tobacco filler was taken from each of the flavor inhalator prepared above and the flavor inhalator used as a control, and the moisture contents in the tobacco fillers (% by mass) were measured using GCTCD in the above-described manner. Furthermore, the content of the aerosol generating agent in the tobacco filler was determined using GC-MS in the above-described manner.

#### 1-3. Results

[0229] FIG. 14 illustrates the relationship between the amount of time during which heating was performed with the microwave oven and the moisture content in the tobacco filler and the relationship between the amount of time during which heating was performed with the microwave oven and the surface temperature of the tobacco filler. FIG. 15 illustrates the relationship between the amount of silica gel and the moisture content in the tobacco filler.

[0230] The results illustrated in FIG. 14 show the following facts. When the amount of time during which heating was performed with the microwave oven was increased, the moisture content in the tobacco filler was reduced. When the amount of time during which heating was performed with the microwave oven was increased, the surface temperature of the tobacco filler was increased. When 20 tobacco sticks (tobacco filler: 5.0 g in total) were heated with a 500-watt

microwave oven for 40 to 60 seconds, a dry tobacco filler having a moisture content of 3% to 5% by mass could be prepared.

[0231] The results illustrated in FIG. 15 show the following facts. When the amount of the silica gel used was increased, the moisture content in the tobacco filler was reduced. When 4 to 10 g of silica gel was used relative to 20 tobacco sticks (tobacco filler: 5.0 g in total), a dry tobacco filler having a moisture content of 3% to 5% by mass could be prepared.

[0232] The above results confirm that a dry tobacco filler having an intended moisture content can be prepared by adjusting the amount of heating time and the amount of the desiccant used and thereby changing the degree to which drying is performed.

[0233] The content of the aerosol generating agent in the tobacco filler was as follows.

- [0234] Control: 15.60% by mass
- [0235] Microwave drying, 20 seconds: 15.55% by mass
- [0236] Microwave drying, 40 seconds: 16.72% by mass
- [0237] Microwave drying, 60 seconds: 16.25% by mass
- [0238] Microwave drying, 80 seconds: 15.29% by mass
- [0239] Microwave drying, 100 seconds: 14.74% by mass
- [0240] Silica gel drying, 2 g: 15.11% by mass
- [0241] Silica gel drying, 4 g: 15.38% by mass
- [0242] Silica gel drying, 6 g: 15.12% by mass
- [0243] Silica gel drying, 8 g: 15.43% by mass
- [0244] Silica gel drying, 10 g: 15.59% by mass

#### [Reference Example B2] Mainstream Smoke Temperature and Tip Temperature

#### 2-1. Analysis of Mainstream Smoke Temperature and Tip Temperature

[0245] The flavor inhalator prepared in Reference Example B1 and the flavor inhalator used as a control were heated using a heating device for Ploom S (produced by Japan Tobacco Inc.). The heating device had the structure illustrated in FIG. 5. After heating, the flavor inhalators were inhaled using an automatic inhalator.

[0246] After inhalation, the temperature of the mainstream smoke and the surface temperature of the mouthpiece end of the flavor inhalator (hereinafter, this surface temperature is referred to as “tip temperature”) were analyzed.

#### (Mainstream Smoke Temperature)

[0247] A thermocouple (product name: produced by TOA Electric Inc., model No. TI-SP-K) was disposed at a position 7 mm away from the mouthpiece end of the flavor inhalator toward the downstream, and the temperature of the mainstream smoke was measured at intervals of 0.1 seconds. The maximum value measured during the measurement period was determined as “mainstream smoke temperature”.

#### (Tip Temperature)

[0248] A thermocouple (product name: produced by TOA Electric Inc., model No. TI-SP-K) was disposed on the surface of the tipping paper at a position 5 mm away from the mouthpiece end of the flavor inhalator toward the upstream, and the temperature of the mainstream smoke was

measured at intervals of 0.1 seconds. The maximum value measured during the measurement period was determined as “tip temperature”.

## 2-2. Results

**[0249]** FIG. 16 illustrates the relationship between the moisture content in the tobacco filler and the temperature of the mainstream smoke and the relationship between the moisture content in the tobacco filler and the tip temperature.

**[0250]** The results illustrated in FIG. 16 show the following facts. Regardless of whether microwave drying or silica gel drying was performed, when the moisture content in the tobacco filler was reduced, the temperature of the mainstream smoke could be reduced accordingly. Moreover, regardless of whether microwave drying or silica gel drying was performed, when the moisture content in the tobacco filler was reduced, the tip temperature could be reduced accordingly.

**[0251]** The above results confirm that, when a tobacco filler having a low moisture content is included in a flavor inhalator, the user is unlikely to sense the heat of the aerosol or the heat of the mouthpiece end of the article upon inhalation.

### [Reference Example B3] Contents of Nicotine, Glycerine, and Propylene Glycol in Mainstream Smoke

## 3-1. Analysis of Contents of Nicotine, Glycerine, and Propylene Glycol in Mainstream Smoke

**[0252]** The contents of nicotine, glycerine, and propylene glycol in the mainstream smoke generated from each of the flavor inhalator prepared in Reference Example B1 and the flavor inhalator used as a control were measured as described below. Specifically, the mainstream smoke was collected and subjected to extraction with a predetermined amount of ethanol (10 to 100 mL, which was adjusted appropriately in accordance with the amount of the mainstream smoke), and the contents of the above components were measured using GC-MS.

## 3-2. Results

**[0253]** FIG. 17 illustrates the relationship between the moisture content in the tobacco filler and the content of nicotine in the mainstream smoke. FIG. 18 illustrates the relationship between the moisture content in the tobacco filler and the content of glycerine in the mainstream smoke. FIG. 19 illustrates the relationship between the moisture content in the tobacco filler and the content of propylene glycol in the mainstream smoke. Note that, in the above drawings, the contents of the nicotine, glycerine, and propylene glycol in the mainstream smoke at the first puff are shown.

**[0254]** The results illustrated in the above drawings show the following facts.

**[0255]** In the case where microwave drying was performed, when the moisture content in the tobacco filler was 5% by mass or less, the content of nicotine in the mainstream smoke was sharply increased. Moreover, when the moisture content in the tobacco filler was below 3% by mass, the increase in the content of nicotine in the mainstream smoke was accelerated. Similarly, in the case where microwave drying was performed, when the moisture content in the

tobacco filler was 5% by mass or less, the content of glycerine in the mainstream smoke was also sharply increased and, when the moisture content in the tobacco filler was below 3% by mass, the increase in the glycerine content was accelerated. Similarly, in the case where microwave drying was performed, when the moisture content in the tobacco filler was 5% by mass or less, the content of propylene glycol in the mainstream smoke was also sharply increased and, when the moisture content in the tobacco filler was below 3% by mass, the increase in the propylene glycol content was accelerated.

**[0256]** It is considered that the above phenomenon occurred because the cell membranes and cell walls of the tobacco material were damaged as a result of quick drying performed with the microwave oven and the likelihood of nicotine, glycerine, and propylene glycol included in the tobacco material migrating into the mainstream smoke was increased consequently. Since the above phenomenon significantly occurred particularly at the initial puff, it is considered that the above phenomenon affects the first impression of the smoke taste. The sudden release of a tobacco flavor component may adversely affect the smoke taste (e.g., a harsh taste or stimulation). Therefore, in the case where microwave drying is performed, for limiting the negative impacts on the smoke taste, the moisture content in the tobacco filler is preferably 3% to 5% by mass and is more preferably 4% to 5% by mass.

**[0257]** On the other hand, in the case where silica gel drying was performed, when the moisture content in the tobacco filler was reduced to 5% by mass or less, the contents of nicotine, glycerine, and propylene glycol in the mainstream smoke could be mildly increased. In other words, in the case where silica gel drying was performed, when the moisture content in the tobacco filler was reduced to 5% by mass or less, the increases in the contents of nicotine, glycerine, and propylene glycol in the mainstream smoke were mild compared with microwave drying.

**[0258]** The reasons for which the above results were obtained in the case where silica gel drying was performed are considered as follows. Specifically, it is considered that, although the cell membranes and cell walls of the tobacco material were not damaged by silica gel drying, the amount of water vapor was generated upon heating was reduced as a result of the reduction in the moisture content in the tobacco filler. This presumably increased the temperature of the tobacco filler and resulted in the mild increases in the contents of nicotine, glycerine, and propylene glycol in the mainstream smoke. Thus, since silica gel drying enables the contents of nicotine, glycerine, and propylene glycol in the mainstream smoke to be mildly increased, silica gel drying is unlikely to adversely affect the smoke taste (e.g., a harsh taste or stimulation) compared with microwave drying.

**[0259]** Moreover, the results illustrated in FIG. 14 show that, in the case where microwave drying is performed, the surface temperature of the tobacco filler is increased to about 90° C. when the moisture content in the tobacco filler is reduced to about 3% by mass. Accordingly, for drying the tobacco filler while limiting the negative impacts on the smoke taste (e.g., a harsh taste or stimulation), the tobacco filler is preferably dried such that the surface temperature of the tobacco filler is 90° C. or less.

**[0260]** The above results confirm that, when the moisture content in the tobacco filler is reduced to 3% to 5% by mass, the content of the tobacco flavor source in the tobacco

mainstream smoke and the amount of aerosol (i.e., smoke) can be increased and the feel of smoking can be improved.

[Reference Example B4] Content of Aerosol  
Generating Agent in Tobacco Filler

[0261] In Reference Example B4, the content of the aerosol generating agent (i.e., mixture of glycerine and propylene glycol) in the tobacco filler was changed. In Test 1, while the content of propylene glycol in the tobacco filler was fixed at about 0.5% by mass, the content of glycerine in the tobacco filler was changed. In Test 2, while the content of glycerine in the tobacco filler was fixed at about 15% by mass, the content of propylene glycol in the tobacco filler was changed.

4-1. Preparation of Dry Tobacco Filler and Preparation of  
Flavor Inhalator

[0262] A flavor inhalator was prepared in accordance with the method described in Reference Example B1, and a tobacco filler (i.e., dry tobacco filler) was taken from the flavor inhalator. The moisture content in the dry tobacco filler was 13.69% by mass.

4-2. Analysis of Content of Aerosol Generating Agent in Dry  
Tobacco Filler

[0263] A tobacco filler was taken from the flavor inhalator prepared in 4-1, and the content of the aerosol generating agent (i.e., glycerine and propylene glycol) in the tobacco filler was determined using GC-MS in the above-described manner.

4-3. Analysis of Contents of Nicotine, Glycerine, and  
Propylene Glycol in Mainstream Smoke

[0264] The contents of nicotine, glycerine, and propylene glycol in the mainstream smoke generated from the flavor inhalator prepared in 4-1 were determined using GC-MS in the above-described manner.

4-4. Results

[0265] FIGS. 20A and 20B illustrate the results of Test 1. FIG. 20A illustrates the relationship between the content of the aerosol generating agent in the tobacco filler and the content of each component in the mainstream smoke. FIG. 20B illustrates the relationship between the content of glycerine in the tobacco filler and the content of each component in the mainstream smoke.

[0266] FIGS. 21A and 21B illustrate the results of Test 2. FIG. 21A illustrates the relationship between the content of the aerosol generating agent in the tobacco filler and the content of each component in the mainstream smoke. FIG. 21B illustrates the relationship between the content of propylene glycol in the tobacco filler and the content of each component in the mainstream smoke.

[0267] In the above drawings, "G" represents glycerine, "PG" represents propylene glycol, "G+PG" represents a mixture of glycerine and propylene glycol, and "Nic" represents nicotine.

[0268] The results illustrated in FIGS. 20A and 20B show the following facts. Although the content of the aerosol generating agent (G+PG) in the mainstream smoke was increased with the increase in the content of the aerosol generating agent (G+PG) in the tobacco filler, the rate of

increase in the content of the aerosol generating agent (G+PG) in the mainstream smoke was gradually reduced. Specifically, when the content of the aerosol generating agent (G+PG) in the tobacco filler was 20% by mass or more, the content of the aerosol generating agent (G+PG) in the mainstream smoke was hardly increased with the increase in the content of the aerosol generating agent (G+PG) in the tobacco filler. When the content of the aerosol generating agent (G+PG) in the tobacco filler was 20% by mass or more, the content of glycerine in the mainstream smoke was also hardly increased and the content of propylene glycol in the mainstream smoke was slightly reduced with the increase in the content of the aerosol generating agent (G+PG) in the tobacco filler. When the content of the aerosol generating agent (G+PG) in the tobacco filler was 20% by mass or more, the content of nicotine in the mainstream smoke was not increased at all with the increase in the content of the aerosol generating agent (G+PG) in the tobacco filler.

[0269] The results illustrated in FIGS. 21A and 21B show the following facts. Although the content of the aerosol generating agent (G+PG) in the mainstream smoke was increased with the increase in the content of the aerosol generating agent (G+PG) in the tobacco filler, the rate of increase in the content of the aerosol generating agent (G+PG) in the mainstream smoke was gradually reduced. Specifically, when the content of propylene glycol in the tobacco filler exceeded 3% by mass, the content of the aerosol generating agent (G+PG) in the mainstream smoke was hardly increased with the increase in the content of propylene glycol in the tobacco filler. When the content of propylene glycol in the tobacco filler exceeded 3% by mass, the content of propylene glycol in the mainstream smoke was also hardly increased and the content of glycerine in the mainstream smoke was reduced with the increase in the content of propylene glycol in the tobacco filler. When the content of propylene glycol in the tobacco filler exceeded 3% by mass, the content of nicotine in the mainstream smoke was slightly reduced with the increase in the content of propylene glycol in the tobacco filler.

[0270] When the aerosol generating agent is heated, it is vaporized to form a vapor, a tobacco flavor component, such as nicotine, migrates into the vapor, and an aerosol (i.e., mainstream smoke) is generated consequently. Since heat is lost due to the vaporization of the aerosol generating agent, the amount of heat lost by vaporization is increased with the increase in the content of the aerosol generating agent in the tobacco filler. This reduces the efficiency with which the tobacco filler is heated. It is considered that, for the above reasons, the rate of migration of the high-boiling point components (i.e., glycerine and nicotine) to the aerosol was reduced with the increase in the content of the aerosol generating agent in the tobacco filler.

[0271] On the basis of the above-described results, it is considered that the content of the aerosol generating agent in the tobacco filler is preferably less than 20% by mass, is more preferably 19% by mass or less, and is further preferably 15% to 19% by mass. On the basis of the above-described results, it is also considered that, in the case where the aerosol generating agent is a mixture of glycerine and propylene glycol, the content of propylene glycol in the tobacco filler is preferably 3% by mass or less and is more preferably 1% to 3% by mass.

[0272] Aspects are described below.

## Aspect 1

**[0273]** A tobacco sheet for non-combustion-heating-type flavor inhalators, the tobacco sheet including a fibrous material.

## Aspect 2

**[0274]** The sheet according to aspect 1, further including a dry tobacco material and an aerosol generating agent, the dry tobacco material having a moisture content of more than 5% by mass and 7.5% by mass or less.

## Aspect 3

**[0275]** The sheet according to aspect 2, wherein the aerosol generating agent is a mixture of glycerine and propylene glycol.

## Aspect 4

**[0276]** The sheet according to aspect 1, further including a dry tobacco material and an aerosol generating agent, a content of the aerosol generating agent in the sheet being less than 20% by mass, the dry tobacco material having a moisture content of 3% to 5% by mass.

## Aspect 5

**[0277]** The dry tobacco filler according to aspect 4, wherein the aerosol generating agent is a mixture of propylene glycol and glycerine.

## Aspect 6

**[0278]** A non-combustion-heating-type flavor inhalator including a tobacco-containing segment including the sheet according to any one of aspects 1 to 5.

## Aspect 7

**[0279]** A non-combustion-heating-type flavor inhalation system including:

**[0280]** the non-combustion-heating-type flavor inhalator according to aspect 6; and

**[0281]** a heating apparatus that heats the tobacco-containing segment.

**[0282]** [1] A tobacco sheet for non-combustion-heating-type flavor inhalators, the tobacco sheet including a fibrous material.

**[0283]** [2] The tobacco sheet for non-combustion-heating-type flavor inhalators according to [1], wherein the content of the fibrous material in the tobacco sheet is 5% to 50% by mass with the amount of the tobacco sheet being 100% by mass.

**[0284]** [3] The tobacco sheet for non-combustion-heating-type flavor inhalators according to [1] or [2], wherein the fibrous material is at least one selected from the group consisting of a fibrous pulp, a fibrous tobacco material, and fibrous synthetic cellulose.

**[0285]** [4] The tobacco sheet for non-combustion-heating-type flavor inhalators according to [3], wherein the fibrous material is a fibrous pulp.

**[0286]** [5] The tobacco sheet for non-combustion-heating-type flavor inhalators according to [4], wherein the tobacco sheet further includes a tobacco raw material.

**[0287]** [6] The tobacco sheet for non-combustion-heating-type flavor inhalators according to [5], wherein the tobacco

raw material is at least one tobacco powder selected from the group consisting of powders of leaf tobacco, midrib, and residual stems.

**[0288]** [7] The tobacco sheet for non-combustion-heating-type flavor inhalators according to [5] or [6], wherein the content of the tobacco raw material is 30% to 91% by mass with the amount of the tobacco sheet being 100% by mass.

**[0289]** [8] The tobacco sheet for non-combustion-heating-type flavor inhalators according to any one of [4] to [7], wherein the tobacco sheet further includes a shaping agent.

**[0290]** [9] The tobacco sheet for non-combustion-heating-type flavor inhalators according to [8], wherein the shaping agent is at least one selected from the group consisting of a polysaccharide, a protein, and a synthetic polymer.

**[0291]** [10] The tobacco sheet for non-combustion-heating-type flavor inhalators according to [8] or [9], wherein the content of the shaping agent in the tobacco sheet is 0.1% to 15% by mass with the amount of the tobacco sheet being 100% by mass.

**[0292]** [11] The tobacco sheet for non-combustion-heating-type flavor inhalators according to any one of [1] to [10], wherein the tobacco sheet further includes an aerosol generating agent.

**[0293]** [12] The tobacco sheet for non-combustion-heating-type flavor inhalators according to [11], wherein the aerosol generating agent is at least one selected from the group consisting of glycerine, propylene glycol, and 1,3-butanediol.

**[0294]** [13] The tobacco sheet for non-combustion-heating-type flavor inhalators according to [11] or [12], wherein the content of the aerosol generating agent in the tobacco sheet is 5% to 50% by mass with the amount of the tobacco sheet being 100% by mass.

**[0295]** [14] A non-combustion-heating-type flavor inhalator including a tobacco-containing segment including the tobacco sheet for non-combustion-heating-type flavor inhalators according to any one of [1] to [13].

**[0296]** [15] A non-combustion-heating-type flavor inhalation system including:

**[0297]** the non-combustion-heating-type flavor inhalator according to [14]; and

**[0298]** a heating apparatus that heats the tobacco-containing segment.

**[0299]** Preferable embodiments are described in summary below.

**[0300]** [A1] A dry tobacco filler including a dry tobacco material and an aerosol generating agent, the dry tobacco filler having a moisture content of more than 5% by mass and 7.5% by mass or less.

**[0301]** [A2] The dry tobacco filler according to [A1], wherein the moisture content is 5.1% to 7.5% by mass, is preferably 5.1% to 7.0% by mass, and is more preferably 5.5% to 7.0% by mass.

**[0302]** [A3] The dry tobacco filler according to [A1] or [A2], wherein the dry tobacco material is a tobacco molded body.

**[0303]** [A4] The dry tobacco filler according to any one of [A1] to [A3], wherein the aerosol generating agent is a mixture of glycerine and propylene glycol.

**[0304]** [B1] A non-combustion-heating-type flavor inhalator including a tobacco rod, the tobacco rod including a dry tobacco filler including a dry tobacco material and an aerosol generating agent, the dry tobacco filler having a moisture content of more than 5% by mass and 7.5% by

mass or less, and a wrapping paper wrapped around the dry tobacco filler; a filter; and a tipping member with which the tobacco rod and the filter are connected to each other.

**[0305]** [B2] The non-combustion-heating-type flavor inhalator according to [B1], wherein the moisture content is 5.1% to 7.5% by mass, is preferably 5.1% to 7.0% by mass, and is more preferably 5.5% to 7.0% by mass.

**[0306]** [B3] The non-combustion-heating-type flavor inhalator according to [B1] or [B2], wherein the dry tobacco material is a tobacco molded body.

**[0307]** [B4] The non-combustion-heating-type flavor inhalator according to any one of [B1] to [B3], wherein the aerosol generating agent is a mixture of glycerine and propylene glycol.

**[0308]** [C1] A non-combustion-heating-type flavor inhalation system including the non-combustion-heating-type flavor inhalator according to any one of [B1] to [B4] and an aerosol generation apparatus.

**[0309]** [D1] A packaged product including a package; at least one non-combustion-heating-type flavor inhalator that is accommodated in the package and that includes a tobacco filler including a tobacco material and an aerosol generating agent; and a desiccant incorporated in the package in an amount necessary for the moisture content in the tobacco filler reaching an equilibrium moisture content of more than 5% by mass and 7.5% by mass or less,

**[0310]** wherein the moisture content in the tobacco filler reaches an equilibrium moisture content of more than 5% by mass and 7.5% by mass or less while the tobacco filler is inside the package.

**[0311]** [D2] The packaged product according to [D1], wherein the equilibrium moisture content is 5.1% to 7.5% by mass, is preferably 5.1% to 7.0% by mass, and is more preferably 5.5% to 7.0% by mass.

**[0312]** [D3] The packaged product according to [D1] or [D2], wherein the tobacco material is a tobacco molded body.

**[0313]** [D4] The packaged product according to any one of [D1] to [D3], wherein the aerosol generating agent is a mixture of glycerine and propylene glycol.

**[0314]** [E1] A method for producing a dry tobacco filler, the method including:

**[0315]** drying a tobacco filler including a tobacco material and an aerosol generating agent to prepare a dry tobacco filler having a moisture content of more than 5% by mass and 7.5% by mass or less.

**[0316]** [E2] The method according to [E1], wherein the drying is performed by microwave heating.

**[0317]** [E3] The method according to [E1] or [E2], wherein the drying is performed such that the surface temperature of the tobacco filler is 65° C. or less.

**[0318]** [E4] The method according to any one of [E1] to [E3], wherein the drying is performed by placing the tobacco filler in the presence of a desiccant.

**[0319]** [E5] The method according to any one of [E1] to [E4], wherein the moisture content is 5.1% to 7.5% by mass, is preferably 5.1% to 7.0% by mass, and is more preferably 5.5% to 7.0% by mass.

**[0320]** [E6] The method according to any one of [E1] to [E5], wherein the tobacco material is a tobacco molded body.

**[0321]** [E7] The method according to any one of [E1] to [E6], wherein the aerosol generating agent is a mixture of glycerine and propylene glycol.

**[0322]** [F1] A dry tobacco filler produced by the method according to any one of [E1] to [E7].

**[0323]** Preferable embodiments are described in summary below.

**[0324]** [a1] A dry tobacco filler including a dry tobacco material and an aerosol generating agent, the content of the aerosol generating agent being less than 20% by mass, the dry tobacco filler having a moisture content of 3% to 5% by mass.

**[0325]** [a2] The dry tobacco filler according to [a1], wherein the moisture content is 3.5% to 5% by mass and is preferably 4% to 5% by mass.

**[0326]** [a3] The dry tobacco filler according to [a1] or [a2], wherein the content of the aerosol generating agent is 19% by mass or less and is preferably 15% to 19% by mass.

**[0327]** [a4] The dry tobacco filler according to any one of [a1] to [a3], wherein the dry tobacco material is a tobacco molded body.

**[0328]** [a5] The dry tobacco filler according to any one of [a1] to [a4], wherein the aerosol generating agent is a mixture of propylene glycol and glycerol.

**[0329]** [a6] The dry tobacco filler according to [a5], wherein the content of the propylene glycol is 3% by mass or less and is preferably 1% to 3% by mass.

**[0330]** [b1] A non-combustion-heating-type flavor inhalator including:

**[0331]** a tobacco rod including a dry tobacco filler including a dry tobacco material and an aerosol generating agent, the content of the aerosol generating agent being less than 20% by mass, the dry tobacco filler having a moisture content of 3% to 5% by mass, and a wrapping paper wrapped around the dry tobacco filler;

**[0332]** a filter; and

**[0333]** a tipping member with which the tobacco rod and the filter are connected to each other.

**[0334]** [b2] The non-combustion-heating-type flavor inhalator according to [b1], wherein the moisture content is 3.5% to 5% by mass and is preferably 4% to 5% by mass.

**[0335]** [b3] The non-combustion-heating-type flavor inhalator according to [b1] or [b2], wherein the content of the aerosol generating agent is 19% by mass or less and is preferably 15% to 19% by mass.

**[0336]** [b4] The non-combustion-heating-type flavor inhalator according to any one of [b1] to [b3], wherein the dry tobacco material is a tobacco molded body.

**[0337]** [b5] The non-combustion-heating-type flavor inhalator according to any one of [b1] to [b4], wherein the aerosol generating agent is a mixture of propylene glycol and glycerol.

**[0338]** [b6] The non-combustion-heating-type flavor inhalator according to [b5], wherein the content of the propylene glycol is 3% by mass or less and is preferably 1% to 3% by mass.

**[0339]** [c1] A non-combustion-heating-type flavor inhalation system including the non-combustion-heating-type flavor inhalator according to any one of [b1] to [b6] and an aerosol generation apparatus.

**[0340]** [d1] A packaged product including:

**[0341]** a package;

**[0342]** at least one non-combustion-heating-type flavor inhalator that is accommodated in the package and that includes a tobacco filler including a tobacco material and an aerosol generating agent; and

[0343] a desiccant incorporated in the package in an amount necessary for the moisture content in the tobacco filler reaching an equilibrium moisture content of 3% to 5% by mass,

[0344] wherein the moisture content in the tobacco filler reaches an equilibrium moisture content of 3% to 5% by mass while the tobacco filler is inside the package.

[0345] [d2] The packaged product according to [d1], wherein the equilibrium moisture content is 3.5% to 5% by mass and is preferably 4% to 5% by mass.

[0346] [d3] The packaged product according to [d1] or [d2], wherein the content of the aerosol generating agent is less than 20% by mass, is preferably 19% by mass or less, and is more preferably 15% to 19% by mass.

[0347] [d4] The packaged product according to any one of [d1] to [d3], wherein the tobacco material is a tobacco molded body.

[0348] [d5] The packaged product according to any one of [d1] to [d4], wherein the aerosol generating agent is a mixture of propylene glycol and glycerol.

[0349] [d6] The packaged product according to [d5], wherein the content of the propylene glycol is 3% by mass or less and is preferably 1% to 3% by mass.

[0350] [e1] A method for producing a dry tobacco filler, the method including drying a tobacco filler including a tobacco material and an aerosol generating agent such that the surface temperature of the tobacco filler is 90° C. or less to prepare a dry tobacco filler having a moisture content of 3% to 5% by mass.

[0351] [e2] The method according to [e1], wherein the drying is performed such that the surface temperature of the tobacco filler is 65° C. or less.

[0352] [e3] The method according to [e1] or [e2], wherein the drying is performed at room temperature and a humidity of 30% or less.

[0353] [e4] The method according to any one of [e1] to [e3], wherein the drying is performed at 5° C. to 35° C., preferably at 15° C. to 25° C., at a humidity of 10% to 30%, and preferably at a humidity of 15% to 25%.

[0354] [e5] The method according to any one of [e1] to [e4], wherein the drying is performed by placing the tobacco filler in the presence of a desiccant.

[0355] [e6] The method according to any one of [e1] to [e5], wherein the moisture content is 3.5% to 5% by mass and is preferably 4% to 5% by mass.

[0356] [e7] The method according to any one of [e1] to [e6], wherein the content of the aerosol generating agent in the dry tobacco filler is less than 20% by mass, is preferably 19% by mass or less, and is more preferably 15% to 19% by mass.

[0357] [e8] The method according to any one of [e1] to [e7], wherein the tobacco material is a tobacco molded body.

[0358] [e9] The method according to any one of [e1] to [e8], wherein the aerosol generating agent is a mixture of propylene glycol and glycerol.

[0359] [e10] The method according to [e9], wherein the content of the propylene glycol in the dry tobacco filler is 3% by mass or less and is preferably 1% to 3% by mass.

[0360] [f1] A dry tobacco filler produced by the method according to any one of [e1] to [e10].

#### REFERENCE SIGNS LIST

- [0361] 1 non-combustion-heating-type flavor inhalator
  - [0362] 2 tobacco-containing segment
  - [0363] 3 cooling segment
  - [0364] 4 center-hole segment
  - [0365] 5 filter segment
  - [0366] 6 mouthpiece segment
  - [0367] 7 tubular member
  - [0368] 8 perforations
  - [0369] 9 second filler layer
  - [0370] 10 second inner plug wrapper
  - [0371] 11 outer plug wrapper
  - [0372] 12 mouthpiece lining paper
  - [0373] 13 heating apparatus
  - [0374] 14 body
  - [0375] 15 heater
  - [0376] 16 metal pipe
  - [0377] 17 battery unit
  - [0378] 18 control unit
  - [0379] 19 recess
  - [0380] T1a tobacco material
  - [0381] T1b dry tobacco material
  - [0382] T2 aerosol generating agent
  - [0383] T3a untreated tobacco filler
  - [0384] T3b dry tobacco filler
1. A tobacco sheet for non-combustion-heating-type flavor inhalators, the tobacco sheet comprising:
    - a fibrous material;
    - a dry tobacco material;
    - and an aerosol generating agent,
 wherein the dry tobacco material has a moisture content of more than 5% by mass and 7.5% by mass or less.
  2. (canceled)
  3. The sheet according to claim 1, wherein the aerosol generating agent is a mixture of glycerine and propylene glycol.
  4. The sheet according to claim 1, wherein a content of the aerosol generating agent in the sheet is less than 20% by mass.
  5. The dry tobacco sheet according to claim 4, wherein the aerosol generating agent is a mixture of propylene glycol and glycerine.
  6. A non-combustion-heating-type flavor inhalator comprising a tobacco-containing segment including the sheet according to claim 1.
  7. A non-combustion-heating-type flavor inhalation system comprising:
    - the non-combustion-heating-type flavor inhalator according to claim 6; and
    - a heating apparatus that heats the tobacco-containing segment.
  8. (canceled)
  9. A non-combustion-heating-type flavor inhalator comprising a tobacco-containing segment including the sheet according to claim 3.
  10. A non-combustion-heating-type flavor inhalator comprising a tobacco-containing segment including the sheet according to claim 4.
  11. A non-combustion-heating-type flavor inhalator comprising a tobacco-containing segment including the sheet according to claim 5.

\* \* \* \* \*