

No. 794,706.

PATENTED JULY 18, 1905.

W. T. FINE.
WIND WHEEL.

APPLICATION FILED MAY 2, 1905.

2 SHEETS—SHEET 1.

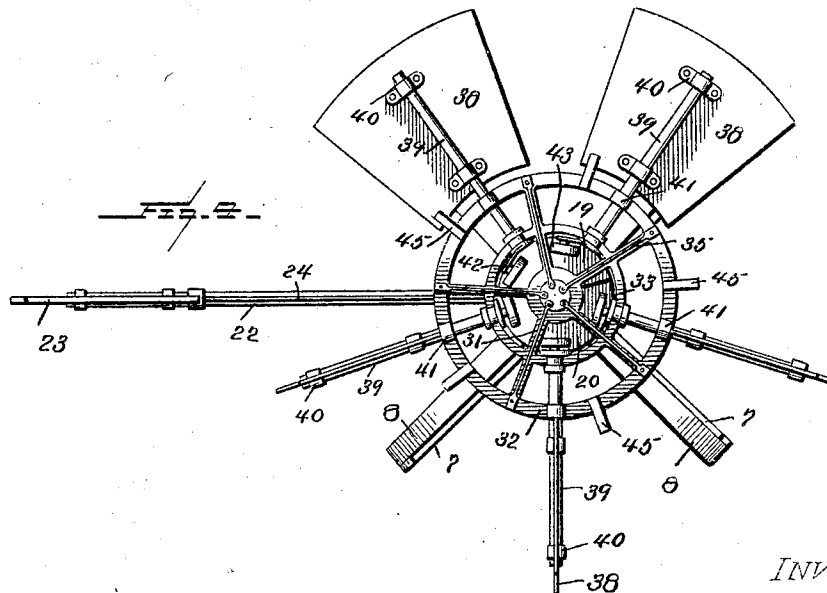
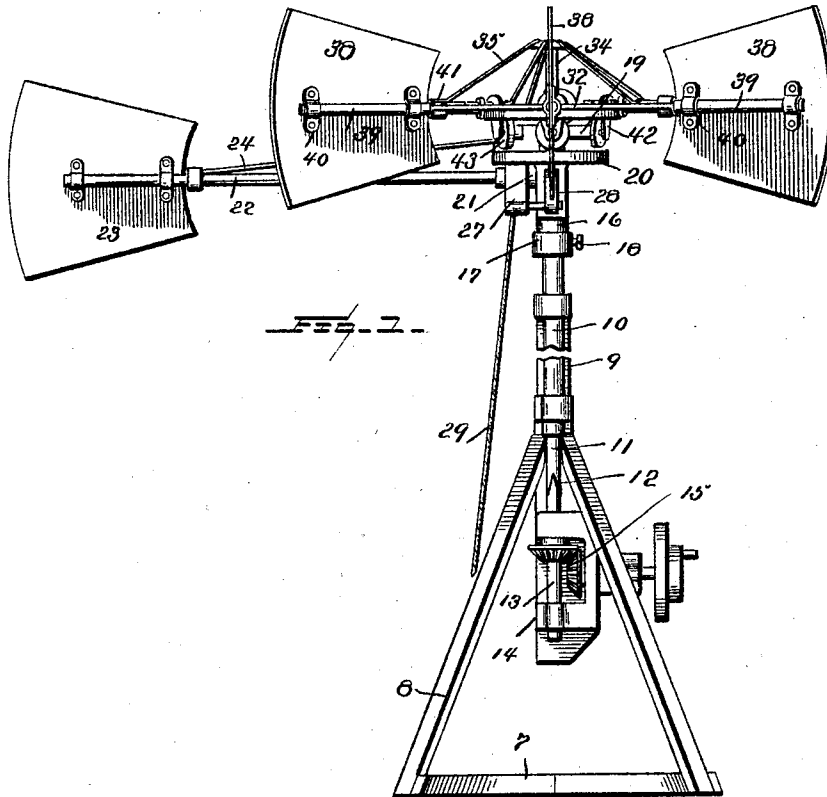

WITNESSES

H. F. Boyle
Ma Schmidt

INVENTOR

Wm. T. Fine

BY *Milo B. Stevens and Co.*
Attorney &

No. 794,706.

PATENTED JULY 18, 1905.

W. T. FINE.
WIND WHEEL.

APPLICATION FILED MAY 2, 1905.

2 SHEETS—SHEET 2.

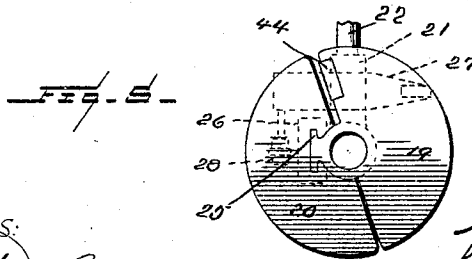
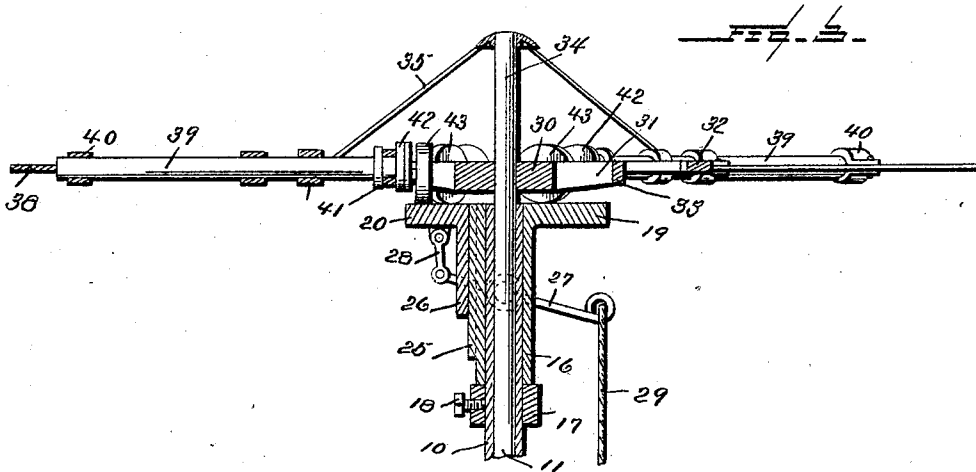
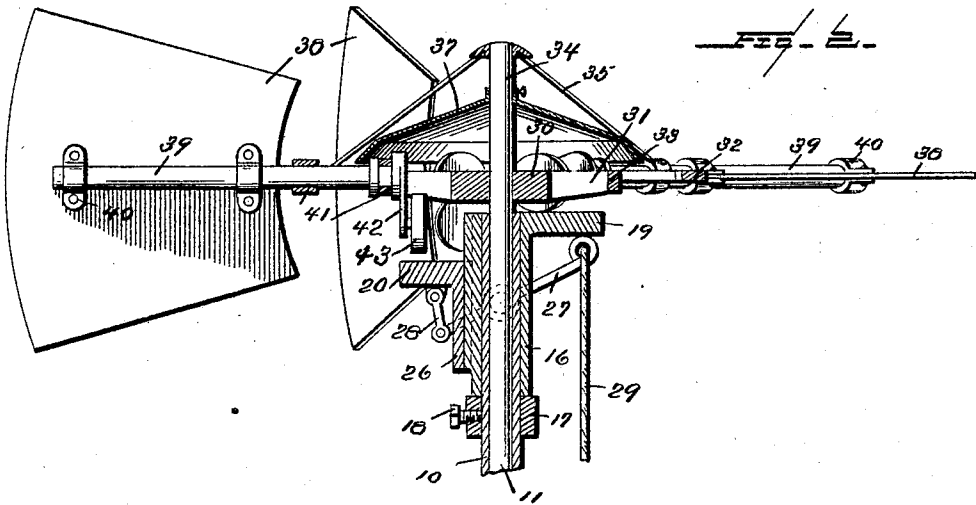

WITNESSES:

M. F. Kyle
Maschmiedt

INVENTOR

Wm. T. Fine

BY *Milo C. Stevens and Co*
Attorney S

UNITED STATES PATENT OFFICE.

WILLIAM T. FINE, OF HOPKINS, MISSOURI, ASSIGNOR OF ONE-THIRD TO
JOHN M. FINE, OF HOPKINS, MISSOURI.

WIND-WHEEL.

SPECIFICATION forming part of Letters Patent No. 794,706, dated July 18, 1905.

Application filed May 2, 1905. Serial No 258,444.

To all whom it may concern:

Be it known that I, WILLIAM T. FINE, a citizen of the United States, residing at Hopkins, in the county of Nodaway and State of Missouri, have invented new and useful Improvements in Wind-Wheels, of which the following is a specification.

My invention relates to wind-wheels, and more particularly that type having horizontally-disposed feathering-blades.

The object of the invention is to provide improved means for throwing the wheel into and out of gear.

A further object is to provide novel means for controlling and regulating the position of the blades according to the force or velocity of the wind.

With these and other objects in view, as will appear more fully hereinafter, the invention consists in certain novel features of construction to be described and claimed.

In the accompanying drawings, Figure 1 is a side elevation of the invention. Fig. 2 is a vertical sectional view. Fig. 3 is a front elevation, partly in section, showing the wheel thrown out of gear. Fig. 4 is a top plan view. Fig. 5 is a plan view of the turn-table.

Referring specifically to the drawings, the tower on which the wheel is mounted comprises sills 7, inclined corner-posts 8 rising therefrom and supporting a vertical post 9. To the latter is secured by straps or other suitable fastening means a vertical tubular standard 10, on which the turn-table is mounted. The main shaft 11 extends through the standard 10 and is coupled at its lower end, as at 12, to a short shaft 13, mounted in bearings 14 on the lower end of the post 9. A suitable gearing 15 is provided for converting and transmitting the motion of the main shaft 11.

The turn-table comprises a tubular casting 16, fitting loosely and rotatably on the standard 10, its lower end being supported on a collar 17, which is adjustably secured to the standard by a set-screw 18. At the top of the casting 16 is a fixed platform 19

and a vertically-movable platform 20 for a purpose to be hereinafter described. Below the platforms is an outwardly-extending socket-piece 21, in which the stem 22 of the vane 23 is secured. The vane is braced by a rod 24. The casting 16 has on one side vertical guides 25, on which the platform 20 slides. The latter has a depending sleeve 26 fitting on the guides and serving to hold the platform from tilting sidewise. The means for elevating and lowering the platform comprises a lever 27, pivoted on the socket-piece 21. One end of the lever is connected to the platform by a link 28, and to the opposite end of the lever an operating rope or cable 29 is fastened. A pull on the rope elevates the platform, and when the rope is released the platform drops down by gravity. The end of the lever 27 to which the operating-rope is attached engages the under side of the platform 19 when the platform 20 is down, and thus holds the latter from dropping off the guides.

The wheel is fast on the main shaft 11 and comprises a hub 30, spokes 31, and two rims 32 and 33, respectively, the first or outer one being made quite thin, so as to offer the least resistance to the wind. Between the rims the spokes are also reduced in thickness for the same reason. The main shaft extends above the wheel a short distance, as at 34, to afford fastening means for radial braces 35, which extend to the outer rim 32, and also a shield 37 for protecting the parts from rain, snow, &c. For the sake of clearness this shield is shown only in Fig. 2 of the drawings.

The blades 38 are fastened to tubular shafts or stems 39 by straps 40, the blades being slotted to receive the shafts. The shafts are mounted in bearings 41 on the rims 32 and 33, and at their inner ends they are fitted with cranks 42, carrying friction-rollers 43. The cranks and collars on the shafts 39 on the opposite side of the rim 33 prevent longitudinal movement of the shafts. The shafts are so located with respect to the spokes that when the blades are in vertical

position the rollers 43 are in contact with said spokes, which thus serve as stops to hold the blades in this position.

The object of the platforms 19 and 20 is to properly present the blades to receive the full force of the wind during their travel in the direction thereof and to feather or present the blades edgewise during their travel against the wind. This is accomplished by lowering the platform 20. The platform 19 is so arranged that when the rollers 43 travel thereon the blades will be presented edgewise to the wind. When the end of the platform is reached, the wheels drop down by gravity, which rocks the shafts and causes the blades to assume a vertical position, and thereby present their faces to the wind. When the rollers again mount the platform 19, the cranks 42 again rock the stems 39 to feather the blades. To throw the wheel out of gear, the platform 20 is elevated to extend flush with the platform 19. In this position the blades will be held edgewise to the wind during the entire revolution of the wheel, whereby it will be rendered inoperative. The extent of the movement of the blades from a horizontal to a vertical position depends on the drop of the rollers, and this can be readily regulated by adjustment of the platform 20. Thus when the latter is lowered so that the rollers clear it altogether the blades are permitted to assume a perfectly vertical position. If it is desired that the blades be presented at an angle to the wind, the platform 20 is elevated proportionately. The platforms are so arranged that the drop takes place at the proper time, and as the position of both platforms with respect to the direction of the wind is directly controlled by the vane they will always be swung into proper position.

During ordinary wind the speed of the wheel is such that the rollers will have sufficient time to drop to their full extent after leaving the platform 19, so that the blades will come to a vertical position to receive the entire force of the wind. When the velocity of the wind increases and the wheel commences to run faster, the rollers by reason of

their speed do not have sufficient time to drop down entirely, but remount the platform before they can do so. The blades are thus presented at an angle to the wind and the speed of the wheel decreases. The wheel is thus self-governing and runs steady and smooth.

At the end of the platform 19 where the rollers mount it a rubber or other suitable buffer 44 will be located. Buffers 45 are also placed on the rim 32 to take up the shock of the blades when they swing to a horizontal position.

Having thus described my invention, what is claimed as new, and desired to be secured by Letters Patent, is—

1. In a wind-wheel, the combination with a support; of a turn-table mounted thereon, and carrying a vane; a fixed, and a vertically-movable platform on the turn-table; a horizontally-disposed wheel; rock-shafts mounted on the wheel, and carrying blades at their outer ends; cranks formed on the inner ends of the shafts, and fitted with rollers cooperating with the platforms to feather the blades; and stops engaged by the rollers when off the fixed platform for limiting the swing of the cranks.

2. In a wind-wheel, the combination with a support; of a turn-table mounted thereon, and having an outwardly-extending stem; a vane secured to said stem; a fixed, and a vertically-movable platform on the turn-table; a lever pivoted on the aforesaid stem, and connected with the movable platform; means for operating the lever to raise and lower said platform; a horizontally-disposed wheel; rock-shafts mounted on the wheel, and carrying blades; and means carried by the shafts, and cooperating with the platforms to feather the blades.

In testimony whereof I have signed my name to this specification in the presence of two subscribing witnesses.

WILLIAM T. FINE.

Witnesses:

PERRY L. CHAMBERS,
JESSE A. SISK.