

(12) INTERNATIONAL APPLICATION PUBLISHED UNDER THE PATENT COOPERATION TREATY (PCT)

(19) World Intellectual Property Organization  
International Bureau



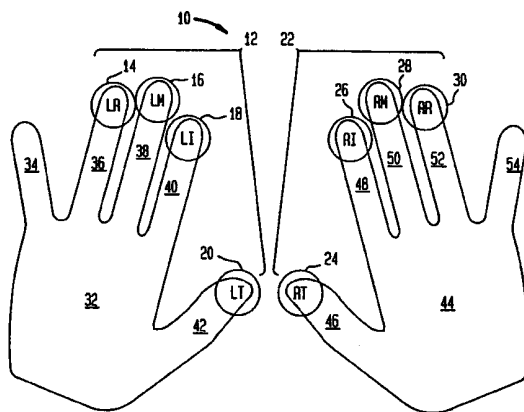
(43) International Publication Date  
31 May 2001 (31.05.2001)

PCT

(10) International Publication Number  
WO 01/39375 A1

- (51) International Patent Classification<sup>7</sup>: H03K 17/94, B41J 5/06, 5/08
- (21) International Application Number: PCT/US99/27998
- (22) International Filing Date:  
29 November 1999 (29.11.1999)
- (25) Filing Language: English
- (26) Publication Language: English
- (71) Applicant and  
(72) Inventor: BURRELL, James, W., IV [US/US]; 2342 Kline Court, Union, NJ 07083-1892 (US).
- (74) Agent: SUTTON, Ezra; Plaza 9, 900 Route 9, Woodbridge, NJ 07095 (US).
- (81) Designated States (*national*): AL, AM, AT, AU, AZ, BA, BB, BG, BR, BY, CA, CH, CN, CU, CZ, DE, DK, EE, ES, FI, GB, GD, GE, GH, GM, HR, HU, ID, IL, IN, IS, JP, KE, KG, KP, KR, KZ, LC, LK, LR, LS, LT, LU, LV, MD, MG, MK, MN, MW, MX, NO, NZ, PL, PT, RO, RU, SD, SE, SG, SI, SK, SL, TJ, TM, TR, TT, UA, UG, UZ, VN, YU, ZW.
- (84) Designated States (*regional*): European patent (AT, BE, CH, CY, DE, DK, ES, FI, FR, GB, GR, IE, IT, LU, MC, NL, PT, SE).
- Published:  
— With international search report.
- For two-letter codes and other abbreviations, refer to the "Guidance Notes on Codes and Abbreviations" appearing at the beginning of each regular issue of the PCT Gazette.*

(54) Title: BRAILLE ARRANGEMENT AND DATA ENTRY SYSTEM AND METHOD FOR 8-KEY



WO 01/39375 A1

(57) Abstract: An improved eight bit binary code used as a system and method for multi-lingual communication on eight sensors, on an alternative eight dot braille arrangement, or as a data entry system and method for chordic eight sensor binary keyboards (10). Vowels are produced on a first set (12) of four binary sensors (14, 16, 18, 20) combined with an unused second set (22) of four binary sensors (24, 26, 28, 30). Consonants are produced on a second set (22) of four binary sensors (24-30) combined with the consonant's preceding binary vowel chord produced on the first set (12) of four binary sensors (14-20). The inner right thumb sensor (24) produces a space when used independently, or a shift function when used simultaneously with a vowel or consonant chord. Punctuation is produced on a second set (22) of four binary sensors (24-30) combined with an unused first set (12) of four binary sensors (14-20). Numbers are produced on a first set (12) of four binary sensors (14-20) combined with a second set (22) of four activated binary sensors (24-30). Functions are produced on a first set (12) of four binary sensors (14-20) combined with three activated binary sensors of a second set (22) of four binary sensors (24-30). The eight bit binary code can produce Latin based alphabets, math symbols, containment chords, cursor movement chords, monetary and other symbols, operating functions, graphics and other punctuation. The eight bit binary code can also be used as a form of finger braille for the deaf-blind to communicate.

## BACKGROUND OF THE INVENTION

### BRAILLE ARRANGEMENT AND DATA ENTRY SYSTEM AND METHOD FOR 8-KEY

Inventor: James W. Burrell IV

This application is a re-filed application Ser. No. 07/829,987, filed 02/03/92 which was abandoned after being rejected. Two corrections were made in the code part of the re-filed application and amended to better help those skilled in the art to understand and use the invention.

1. Field of the Invention

This invention relates to an eight bit binary computer data code used as an eight dot braille arrangement and a system and method for entering or producing a space, letters, numbers, data, symbols, control, etc. on an eight key or sensor binary chordic keyboard manipulated by four digits of a first group by a preferred left hand and by four digits of a second group by a preferred right hand respectively.

2. Description of Related Art

There are a number of well-known, prior art keyboards and systems used for inputting alphanumeric data into typewriters, braille writers, word processors, computers, laptops, PDAs and the like. Unfortunately, most modern systems are inherently slow, difficult to learn, not organized in a logical fashion and/or cumbersome for the general population, including the handicapped and sight disabled.

The best known system is the QWERTY keyboard layout which derives its name from the first six letters of the top row of the alphabet keys or sensors. The QWERTY system has been around for many years and was originally implemented in order to slow down typists so that manual typewriter keys would not jam. A good explanation of the history of the QWERTY keyboard is set forth in an article entitled "TYPING WITH A TWO-HAND CHORD KEYBOARD: WILL THE QWERTY BECOME OBSOLETE?" by Daniel Gopher and David Rajj, IEEE Transactions on Systems, Man, and Cybernetics, Volume 18, No. 4, July-August 1988, pages 601-609.

In response to the relatively slow and cumbersome QWERTY system, some new word processors and computers have moved to a Dvorak layout, although very few. One of the characteristics of the Dvorak keyboard is that the vowels a, o, e, u and i form the first five keys of

the second alphabetic row of the keyboard. The United States Department of the Navy tested the Dvorak design and found up to a twenty percent increase in typing speeds. While improved efficiencies are possible and proven with the Dvorak keyboard, it does have some drawbacks, the major one of which is that the keys are not laid out in an ergonomic fashion to follow the natural positions of the hands. Moreover, because there are more keys than the operator has digits, it is necessary for the operator to move his or her hands frequently and fingers up/down or left/right to find and depress the appropriate key or keys. This tends to reduce the overall speed of the typist.

In order to increase speed, the chordic keyboard was invented. There are a number of chordic keyboards on the market, some of which have sets of linear rows, some have curved rows, some have vertical rows or some have horizontal rows. The common denominator is that it has fewer keys than the common QWERTY keyboard or the Dvorak keyboard, and that chords are employed, i.e. combinations of keys or sensors, to enter or produce specific letters, numbers, symbols or functions. A good example of a modern one handed chordic keyboard for use by either hand is the BAT, U.S. Pat. No. 5,642,108 to Gopher et al., sold by Infogrip, Inc., 812 North Boulevard, Baton Rouge, LA 70802. The BAT keyboard comprises two sets of keys, seven for the left hand and seven for the right. Various combinations of keys, from either hand, form binary chords which enter letters, numbers, punctuation, etc., into a computer for processing. Other keyboards are available for attachment to personal computers and the like in order to provide additional functions or to increase the speed of data entry.

The patent literature describes a number of efforts to improve the speed and efficiency of data entry on keyboards. For example, U.S. Patent 4,680,572 to Meguire, et al. entitled CHORD ENTRY KEYING OF DATA FIELDS describes a keyboard arrangement, which in one embodiment, has eleven keys arranged in two sets of five, for either hand, and a common enter key located between the two hands. The system permits the entry of data in a chord-like fashion provided that the common function key is depressed during a predetermined time frame prior to or after the depression of the last data key. Efforts to arrange keyboard keys in a vertical fashion is also described in certain prior art literature. U.S. Patent 3,428,747 to Alferieff entitled MAN TO MACHINE COMMUNICATION KEYBOARD DEVICE discloses a keyboard arrangement in which the four digits and thumb of the right and left hands, respectively, are positioned adjacent to two sets of keyboards, each having five keys, that are vertical and substantially adjacent to each other. The keyboard system permits the entry of data into a computer, radio system, interface or

the like.

Other keyboard apparatuses and systems of possible relevance include the following U.S.

Patents:

329,675; 477,062; 506,718; 578,785; 753,318; 1,293,023; 1,409,386; 1,487,115;  
1,733,605; 1,771,953; 1,932,914; 1,936,089; 1,998,063; 2,012,924; 2,028,516; 2,031,017;  
2,040,248; 2,150,364; 2,187,592; 2,189,023; 2,190,752; 2,192,594; 2,200,807; 2,282,102;  
2,312,138; 2,390,414; 2,428,605; 2,520,142; 2,532,228; 2,581,665; 2,616,198; 2,634,052;  
2,641,769; 2,718,633; 2,823,468; 2,850,812; 2,972,140; 3,021,611; 3,022,878; 3,102,254;  
3,166,856; 3,184,554; 3,197,889; 3,225,883; 3,234,664; 3,241,115; 3,277,587; 3,369,643;  
3,375,497; 3,381,276; 3,428,747; 3,466,647; 3,507,376; 3,526,892; 3,582,554; 3,633,724;  
3,675,513; 3,772,597; 3,781,802; 3,798,599; 3,818,448; 3,831,147; 3,831,296; 3,833,765;  
3,879,722; 3,929,216; 3,945,482; 3,967,273; 3,970,185; 3,980,823; 3,982,236; 4,042,777;  
4,067,431; 4,074,444; 4,132,976; 4,159,471; 4,185,282; 4,333,097; 4,350,055; 4,360,892;  
4,467,321; 4,494,109; 4,516,939; 4,655,621; 4,680,572; 4,791,408; 4,804,279; 5,087,910;  
5,217,311; 5,281,966; 5,361,083; 5,459,458; 5,486,058; 5,459,458; 5,515,305; 5,642,108,  
and an IBM Technical Disclosure Bulletin Vol. 18 No. 12 dated May 1976 entitled; DIGITAL  
X" TYPEWRITER KEYBOARD which discloses two sets of five ergonomically arranged keys  
for each hand, where each key is operated by one of the ten digits on the left and right hands. The  
two thumb keys each produce a space. The eight finger keys use a three position switch (down,  
away and toward) or a five position switch as home row keys. Downward activation produces  
home row data, away activation produces top alphabetic row data and toward activation produces  
bottom row data found on the QWERTY keyboard.

While the foregoing all appear to represent improvements in the art of keyboard systems,  
they nevertheless tend to be difficult to learn and difficult to use, especially by individuals who are  
sight or hearing impaired. Of all the patents and technologies researched, none use or claim an  
eight bit binary computer code as a data entry means. The most relevant technology to this patent  
application is the eight bit EBCDIC computer code (Extended Binary Coded Decimal Interchange  
Code), the eight bit ASCII and extended ASCII computer code (American Standard Code for  
Information Interchange) and the eight dot computer braille code, which is top dot configured for  
tactile reading.

SUMMARY OF THE INVENTION

Briefly described, the invention comprises an eight bit binary code for use as an alternative eight dot braille arrangement and an alphanumeric data entry system and method for chordic eight key or sensor binary keyboards which permits the entry of vowels with a first group of four binary keys or sensors activated by four digits of the first group or preferred left hand, and the entry of consonants with a second group of four binary keys or sensors activated by four digits of the second group or preferred right hand in simultaneous combination with the consonant's preceding binary vowel chord formed or produced on said first group of four binary keys or sensors activated by the four digits of the first group or preferred left hand. The input keyboard comprises eight binary keys or sensors arranged in two sets of four binary keys or sensors each. The first set of four binary keys or sensors is adapted for convenient depression or activation by the preferred thumb, index, middle and ring digits on the four digits of a first group or preferred left hand. Similarly, the second set of four binary keys or sensors is arranged for convenient depression or activation by four digits of a second group by the preferred thumb, index, middle and ring digits on the four digits of a second group or preferred right hand. The two sets of four binary keys or sensors are preferably arranged where each binary key or sensor is located directly beneath the finger tip, of the activating digit, of an ergonomically positioned hand, preferably in two mirror imaged pairs of adjacent crescents or ergonomically correct mirror imaged pairs to best accommodate the natural ergonomically relaxed hand position of the digits on the hands of a data entry keyboard operator. Alternatively, the two sets may be arranged in two vertical rows substantially parallel to each other so that the keyboard can mimic the layout of an 8-dot braille cell character.

The vowels a, e, i, and o are formed or produced by a binary key or sensor of a first set of four binary keys or sensors activated by a first group of four digits of the first preferred left hand from right to left by depressing or activating independently the preferred thumb digit for the "a", the index digit for the "e", the middle digit for the "i" or ring digit for the "o", respectively, of the first group of four digits of the first preferred left hand group against the corresponding binary key or sensor of the first set of four binary keys or sensors. The vowel u is formed or produced by simultaneously depressing or activating the two inside binary keys or sensors of a first set of four binary keys or sensors by the two inside digits, the preferred index and middle of the first group of four digits of the first preferred left hand group. The vowel y is formed or produced by simultaneously depressing or activating the two outside binary keys or sensors of a first set of four

binary keys or sensors by the two outside digits, the preferred ring and thumb digits of the first group of four digits of the first preferred left hand group. Consonants are formed or produced by simultaneously forming or producing a binary vowel chord with the first set of four binary keys or sensors by a first group of four digits of the first preferred left hand group and simultaneously depressing or activating the appropriate binary keys or sensors of a second set of four binary keys or sensors with the second group of four digits, the preferred thumb, index, middle or ring digit or digits of the second preferred right hand group. Because the vowels a, e, i, o, u and y are relatively evenly distributed throughout the alphabet, it makes logical sense to form the consonants b, c and d with the depression or activation of a binary key or sensor by the preferred thumb digit of the first preferred left hand group (the vowel a) in simultaneous combination with the depression or activation of a binary key or sensor of a second set of four binary keys or sensors by the index digit for the consonant b, middle digit for the consonant c and ring digit for the consonant d, respectively, of the second group of four digits of the second preferred right hand group.

The system enters or produces the number mode by the simultaneous depression or activation of a second set of four binary keys or sensors by a second group of four digits, the preferred thumb, index, middle and ring digits of the second preferred right hand group in simultaneous combination with the entry or production of the desired specific binary number chord with the four digits on the first group of four digits of the preferred left hand group. The first preferred left hand group digits enter or produce the specific chosen binary number chords between 0 and 9 in a reverse binary abacus chordic fashion with the preferred ring digit binary key or sensor of the first preferred left hand group forming or producing the binary number 1, the preferred middle digit binary key or sensor forming or producing the binary number 2, the preferred index digit binary key or sensor forming or producing the binary number 4, the preferred thumb digit binary key or sensor forming or producing the binary number 8, then using binary combinations of the first set of four binary keys or sensors to produce the desired number. The numbers 10, 11, 12, 13 and 14 are used to produce the common math functions, where the binary number 10 chord produces or represents the addition function, the binary number 11 chord produces or represents the multiplication function, the binary number 12 chord produces or represents the subtraction function, the binary number 13 chord produces or represents the division function and the binary number 14 chord produces or represents the equals function. Functions, up to 15, are obtained or represented by the simultaneous depression or activation of a second set of four binary keys or

sensors by three digits of a second group of four digits, the index, middle and ring digits of the second preferred right hand group and the choice of between 1 and 15 binary function mode chords using the previously explained binary abacus number chords with the four digits of the first group of four digits of the first preferred left hand group depressing or activating four binary keys or sensors of the first set of four binary keys or sensors. It is possible to choose a variety of the data entry choices including containment groups, movement chords, operating chords (e.g., reset, space, break, print, etc.), Latin based foreign language vowels, consonants and punctuation, punctuation marks, monetary symbols, symbols and graphics chords, etc.

The eight bit binary code can also be used as a finger braille type of communication by the deaf and blind, where the transmitter transmits the mirror imaged binary data chord from the left hand onto the right hand and the mirror imaged binary data chord from the right hand onto the mirror imaged left hand, so the receiver receives the binary data in its preferred embodiment. This physiological aspect of this method is that the transmitter already knows what they are going to transmit, so they simply switch the four digit binary chords on either hand so that the receiver has the chance to easily process the binary data into words and other types of communication. If an individual is missing a thumb digit, the system can be implemented by using the index, middle, ring and little (pinkie) digit of the left and right hands.

The system is logically developed and implemented so that it is easy to learn and quick to use, especially for those who are handicapped or sight impaired.

These and other features of the present invention will be more fully understood by reference to the following drawings.

#### BRIEF DESCRIPTION OF THE DRAWINGS

FIG. 1A. illustrates a keyboard layout of the preferred embodiment of the present invention in which the preferred thumb, index, middle and ring digits of the first preferred left hand group manipulate an ergonomically positioned first set of four binary keys or sensors and the preferred thumb, index, middle and ring digits of the second preferred right hand group manipulate an ergonomically positioned second set of four binary keys or sensors.

FIG. 1B. is a table illustrating the correspondence between the preferred ring, middle, index and thumb digits of the first preferred left hand group and the second preferred right hand group to eight bit binary numbers in binary octal number notation.

FIG. 1C illustrates in an alternative manner the correspondence between the finger-number

presentation and the digits of the first preferred left and second preferred right hand group, respectively, which correspond to the table illustrated in FIG. 1B.

FIG. 1D. is a table illustrating an alternative 8-dot braille arrangement for the two sets of four digit binary keys or sensors each.

FIG. 1E. illustrates the physical layout of the alternative 8-dot braille system described in the table of FIG. 1D above.

FIG. 1F. illustrates an integrated keyboard layout according to the preferred embodiment of the present invention with the hand positions illustrated in phantom.

FIG. 2A. is a table illustrating how all the vowels are represented on the first preferred left hand group.

FIG. 2B. is a table illustrating how consonants are formed or produced by grouping them with vowels selected by binary chords on a first set of four data entry binary keys or sensors depressed or activated by the first preferred left hand group with a second set of four data entry binary keys or sensors depressed or activated by the second preferred right hand group.

FIG. 2C. is a table illustrating the binary chord fingering for the first preferred left hand group and second preferred right hand group in order to enter or produce the lower case alphabet letters a through z.

FIG. 2D. is a table illustrating the manner in which the capital letters A through Z and certain punctuation symbols are entered or produced.

FIG. 2E. is a table illustrating the manner in which binary number chords are entered or produced.

FIG. 2F. is a table illustrating the manner in which common binary math function chords are entered or produced.

FIG. 2G. is a table illustrating the manner in which binary function key chords are entered or produced.

FIG. 2H. is a table illustrating the manner in which binary containment chord groups are entered or produced.

FIG. 2I. is a table illustrating the manner in which binary movement chords are entered or produced.

FIG. 2J. is a table illustrating the manner in which system operating chords are entered or produced.

FIG. 2K. is a table illustrating the manner in which certain foreign language vowels and



consonants are entered or produced.

FIG. 2L. is a table illustrating the manner in which certain monetary symbols, symbols and graphics binary chords are entered or produced.

FIG. 2M. is a table illustrating how various binary chord groups relate to a corresponding ASCII and extended ASCII 8-bit binary code equivalent.

FIG. 3A. illustrates graphically how the four digits of the first preferred left hand group enter or produce the lower case letter i.

FIG. 3B. illustrates graphically how a binary vowel chord entered or produced by a digit on the first preferred left hand group in simultaneous combination with a data entry binary key or sensor selected by a finger on the second preferred right hand group enters or produces the lower case letter r.

FIG. 3C. illustrates the manner in which depression or activation of the four binary keys or sensors by the digits on the first preferred left hand group and second preferred right hand group select the upper case letter R.

FIG. 3D. illustrates how the digits of the first preferred left hand group select the lower case letter i according to the alternative 8-dot braille system described in FIGS. 1D and 1E.

FIG. 3E. illustrates how a binary vowel chord selected by a digit on the first preferred left hand group in simultaneous combination with a data entry binary key or sensor entered or produced by a finger of the second preferred right hand group enters or produces the lower case letter r according to the alternative 8-dot braille system described in FIGS. 1D and 1E.

FIG. 3F. illustrates the manner in which depression or activation of the four binary keys or sensors by the four digits on the first preferred left and second preferred right hand groups enters or produces the upper case letter R according to the alternative 8-dot braille system described in FIGS. 1D and 1E.

FIG. 4A. illustrates the manner in which the number 0 is entered or produced.

FIG. 4B. illustrates the manner in which the number 9 is entered or produced.

FIG. 4C. illustrates the manner in which the number 23 is entered or produced.

FIG. 5 illustrates how the function mode F12 is entered or produced.

FIG. 6 illustrates the 8-bit binary code represented in an 8-dot braille arrangement with a tactile separator positioned between dots 6 & 7 and dots 2 & 3 for tactile braille reading.

FIG. 7 illustrates a manner in which two individuals, facing each other, can communicate using the eight bit binary code as a finger braille type of communication by the deaf and blind.

where the transmitter transmits the mirror imaged binary data chord from the left hand onto the right hand and the mirror imaged binary data chord from the right hand onto the mirror imaged left hand, so the receiver receives the binary data in its preferred embodiment.

FIG. 8A illustrates a table showing the code which is received by the receiver.

FIG. 8B illustrates a table showing the mirror image code which is transmitted by the sender.

FIG. 9 illustrates a table of the prior art eight bit binary ASCII code.

FIG. 10 illustrates a table of the prior art eight bit binary extended ASCII code.

FIG. 11 illustrates a prior art top vertical view of the most ergonomically designed 8-key chord keyboard found in U.S. Design Patent 381,017, issued Jul. 15, 1997..

FIG. 12 illustrates a prior art front elevation view of the most ergonomically designed 8-key chord keyboard.

FIG. 13 illustrates a prior art right side view of the most ergonomically designed 8-key chord keyboard.

FIG. 14 illustrates a prior art back elevation of the most ergonomically designed 8-key chord keyboard.

FIG. 15 illustrates a prior art bottom view of the most ergonomically designed 8-key chord keyboard with a non-slip bottom..

FIG. 16 illustrates a frontal view of a standing human in an ergonomically relaxed position, where the shoulders, arms, hands and digits (fingers) are in their naturally relaxed positions.

FIG. 17 illustrates the ergonomically relaxed standing body position of FIG. 16, where the arms are bent at the elbows, forming a 90 degree angle, and the forearms are parallel to the ground; where the hands and digits (fingers) remain in the same ergonomically relaxed position of FIG. 17.

FIG. 18 illustrates a perspective view of FIG. 17, while in the seated position.

FIG. 19 illustrates a perspective view of FIG. 18, with the most ergonomically designed 8-key chord keyboard of prior art FIGS. 11 through 15 positioned on the seated lap and directly under the ergonomically positioned hands and digits (fingers).

FIG. 20 illustrates a close up perspective view of FIG. 19

FIG. 21A. illustrates the eight dot braille cell arrangement with individual dot numbering.

FIG. 21B. illustrates a prior art 8-key braille typewriter.

FIG. 22 illustrates a top view of the ergonomically positioned body of FIG. 18, where the

thumb, index, middle and ring digits, of the left and right hands, are activating the four left keys and four right keys on the standard prior art twelve button telephone keypad.

FIG. 23 illustrates a prior art split space bar standard 101-key QWERTY keyboard arrangement operated by the chordic combinations of the thumb, index, middle and ring digits of the left and right hand.

#### DETAILED DESCRIPTION OF THE PREFERRED EMBODIMENT

During the course of this description, like numbers will be used to identify like elements according to the different figures and tables which illustrate the invention.

The layout of the preferred embodiment of the invention 10 is generally illustrated in FIG. 1A. The keyboard system 10 includes eight binary keys or sensors divided up into two sets of four binary keys or sensors each. A first set 12 includes the following four binary keys or sensors 14, 16, 18 and 20 which are preferably adapted to be depressed or activated, respectively, by the ring digit 36, middle digit 38, index digit 40, and thumb digit 42 of the first preferred left hand group 32 of the operator. The little digit 34 of the first preferred left hand group is not used according to the preferred embodiment 10. Similarly, a second set 22 includes the following four binary keys or sensors 24, 26, 28 and 30 which are preferably adapted to be depressed or activated, respectively, by the thumb digit 46, index digit 48, middle digit 50, and ring digit 52 of the second preferred right hand group 44 of the operator. The little digit 54 of the second preferred right hand group is not used, according to the preferred embodiment 10.

FIG. 1B. is a table which illustrates the binary octal number notation represented by the eight binary keys or sensors and FIG. 1C. is another table illustrating the same information in a different format. A useful mnemonic technique is to remember the preferred digit representation is by the phonetic word "TIMR" ("TIMER") which stands for the thumb ("T"), index ("I"), middle ("M"), and ring ("R") digits. For ease of discussion as shown in FIG. 1A., the left ring digit 36 is referred to by the designation LR ("Left-Ring"). Similarly, the following digits have the following representations: left middle digit 38 (LM) ; left index digit 40 (LI) ; left thumb 42 (LT) ; right thumb 46 (RT) ; right index digit 48 (RI) ; right middle digit 50 (RM) and right ring digit 52 (RR).

FIG. 1D is a table illustrating an alternative 8-dot braille arrangement for the two sets in two substantially parallel rows of four binary keys or sensors each. FIG. 1E illustrates the physical layout of the alternative 8-dot braille system described in FIG. 1D above. According to the alternative 8-dot braille system 60, the two sets of four binary keys or sensors each, 61 for the

first preferred left set and 62 for the second preferred right set, are arranged in two substantially parallel vertical rows. The first set 61 incorporates a row of four binary keys or sensors 64, 66, 68 and 70 which are adapted for use by a first preferred left hand group by using the preferred left thumb digit 42 (LT) ; left index digit 40 (LI) ; left middle digit 38 (LM) and left ring digit 36 (LR), respectively. Similarly, the second set 62, incorporates a row of four binary keys or sensors 72, 74, 76 and 78 which are adapted, respectively, for use by a second preferred right hand group by using the preferred right thumb digit 46 (RT) ; right index digit 48 (RI) ; right middle digit 50 (RM), and right ring digit 52 (RR). When used as a form of binary braille finger spelling for the deaf and blind, two individuals face each other, and place their hands in the following touching arrangement: transmitters left hand to receivers right hand and transmitters right hand to receivers left hand, thumb to thumb, digit to digit, etc. When transmitting data, the transmitter transmits binary hand chords from the preferred left hand group to the right hand group and from the preferred right hand group to the left hand group. For example, when transmitting the lower case letter b chord (0001 0100), the transmitter transmits the mirror image binary chord upper case vowel E (0010 1000). The receiver will then receive the lower case letter b. The technique for producing vowel and consonant binary chords is explained in further detail below.

The binary keys or sensors 14-20 and 24-30 may be formed or produced in two separate sets 12 and 22 as shown according to the preferred embodiment of the invention in FIG. 1A. Alternatively, the binary keys or sensors 14-20 and 24-30 can be integrated into a single keyboard 100 as shown in FIG. 1F. Hand groups 32 and 44 are illustrated in phantom to show their natural ergonomic position above the integrated keyboard 100.

All binary vowel chords are created or produced with the first set of four binary keys or sensors by the first preferred left hand group 32 according to the table illustrated in FIG. 2A. The vowels a, e, i and o are entered or produced by independently depressing or activating, respectively, the four binary keys or sensors 20, 18, 16 or 14 of the first set 12 by the preferred thumb digit 42 (LT), the index digit 40 (LI), the middle digit 38 (LM), or the ring digit 36 (LR) on the first preferred left hand group, respectively. The vowel u is formed or produced by simultaneously depressing or activating the two inner binary keys or sensors by the middle digit 38 (LM) and the index digit 40 (LI). These are the two inside digits of the first preferred left hand group 32 and is logically suggestive of the vowel u used in sign language for the deaf. The occasional vowel y is formed or produced by simultaneously depressing or activating the two outside digits 36 (LR) and 42 (LT). These are the two outside digits of the first preferred left hand

group 32 and is logically suggestive of the vowel y used in sign language for the deaf.

All consonants are represented or produced by a second set of four binary keys or sensors by depression or activation with the second preferred right hand group binary chords in simultaneous combination with binary vowel chords formed or produced on the first set of four binary keys or sensors by the first preferred left hand group. The vowel/consonant groupings are illustrated in the table in FIG. 2B. The keyboard system 10 takes advantage of the fact that the vowels a, e, i, o, u and y are somewhat evenly distributed throughout the alphabet separated by either three or five consonants in each case. There are five consonants following the vowels i and o. In the vowel i binary consonant chord grouping, the consonants l, m and n are the consonants more frequently used, and in the vowel o binary consonant chord grouping, the consonants r, s and t are the consonants more frequently used. Therefore, the consonants j, k and p, q are given an extra binary bit each for their second preferred right hand group binary consonant chords. FIG. 2C. is a table summarizing the manner in which lower case English language alphabet letters a through z are formed or produced; either by use of the first set of four binary keys or sensors depressed or activated by the first preferred left hand group exclusively (in the case of forming or producing vowels), or through the use of the first set of four binary keys or sensors depressed or activated by the first preferred left hand group in simultaneous combination with the second set of four binary keys or sensors depressed or activated by the second preferred right hand group (in order to form or to produce consonants).

Capital letters are formed or produced according to the table illustrated in FIG. 2D. Independent activation of the first preferred right thumb binary key or sensor 46 (RT) produces a space. The first preferred right thumb binary key or sensor 24 becomes the shift key when entering or producing vowels or consonants, in order to form or produce upper case capital letters. Also, as shown in the table in FIG. 2D, punctuation marks (.,?! ) are entered or produced with only the second set of four binary keys or sensors depressed or activated by the second preferred right hand group. The logic behind using the second preferred right hand group 44 only is that most punctuation occurs at the far right end of a group of words or a sentence.

FIG. 2E. is a table illustrating the manner in which binary number chords are formed or produced. In order to enter or produce a number, the operator substantially simultaneously depresses or activates all four binary keys or sensors 24, 26, 28 and 30 of a second set of four binary keys or sensors depressed or activated with the preferred digits 46, 48, 50 and 52 of the second preferred right hand group 44 and selects the desired binary number chord for entry with

the first set of four binary keys or sensors depressed or activated by the first preferred left hand group. An unused feature of the keyboard system 10 according to the preferred embodiment is that the individual numbers are entered or produced in reverse binary notation starting with the first preferred ring digit 36 (LR) of the first preferred left hand group 32 and ending with the eighth preferred ring digit 52 (RR). If no binary keys or sensors of the left set 12 are depressed or activated, then the number "0" is entered or produced. Depression or activation of the far left first binary key or sensor 14 by the left ring digit 36 (LR) enters produces the number 1, assuming, of course, that all of the binary keys or sensors 24, 26, 28 and 30 of the second preferred right set of four binary keys or sensors 22 are substantially simultaneously depressed or activated. In this fashion it is possible to enter or produce the individual numbers 0 through 9 by the simultaneous binary chordic depression or activation of all of the four binary keys or sensors of the second set 22 along with the appropriate depression or activation of one or more binary keys or sensors of the first set 12 in a reverse binary fashion to produce the desired binary number. The reason that a reverse binary fashion is chosen is that it is more common to read Latin based alphanumeric data from left to right in the same fashion that letters in words are read in the English language. This keeps the data entry system and method consistent in its format and is an easier way for people to learn to enter information into the system 10.

Common binary math function chords are illustrated in the table of FIG. 2F. The reverse binary equivalents of the numbers 10 through 14 are used, respectively, by the number 10 binary chord to represent or produce the addition (+) symbol or function, the number 11 binary chord to represent or produce the multiplication (x) symbol or function, the number 12 binary chord to represent or produce the subtraction (-) symbol or function, the number 13 binary chord to represent or produce the division (/) symbol or function and the number 14 binary chord to represent or produce the equals (=) symbol or function.

In order to expand the utility of the system, it is important to be able to choose from other function modes. Multifunction binary chord choices are entered or produced according to the table illustrated in FIG. 2G. The multifunction binary chord mode choice is initiated or produced by the substantially simultaneous depression or activation of a second set of four binary keys or sensors depressed or activated by the preferred index digit 48 (RI), middle digit 50 (RM) and ring digit 52 (RR) of the second preferred right hand group 44, in simultaneous combination with the appropriate reverse binary choice of chords on a second set of four binary keys or sensors depressed or activated by the four digits of the first preferred left hand group 32. Up to 15 function

mode choices are possible (F1-F15) given the fact that there are four binary keys or sensors and 15 different distinct binary chordic combinations possible, given the particular binary chordic choice. Note that the functions F1-F15 correspond one for one with the reverse binary number chosen while in the number mode by the four digits of the first preferred left hand group 32.

Additional instructions can be entered or produced by the keyboard system 10 according to the preferred embodiment which are consistent with instructions that also can be entered or produced with the QWERTY keyboard, Dvorak keyboard, or other types of Latin based alphabet foreign language keyboard such as the Spanish, French, German, Italian, Swedish/Finnish, Canadian bilingual along with many other types of Latin based alphabet keyboards known to those of ordinary skill in the art. For example, the table in FIG. 2H illustrates certain binary containment chord groups that have mirror image binary chords. Containment groups are instructions like brackets [ ], parentheses ( ), etc. It is also useful to provide the common movement instructions such as moving a cursor up or down, tab, home, page up or down, etc. These binary movement chords are formed or produced according to the table illustrated in FIG. 2I.

Standard operating and control instructions are generated according to the table illustrated in FIG. 2J. Those operating instructions include, but are not limited to: reset, space, backspace, GO TO, break, tab, start and end of text, print, print, inquiry, substitution, figure shift, alternate, carriage return, scroll, shift, etc.

It is also possible to use the keyboard system 10 to form or produce vowels, consonants and punctuation in foreign Latin based languages. The table in FIG. 2K illustrates the manner in which common characters in foreign languages are formed or produced according to the preferred keyboard system 10 of the present invention.

Finally, specialty symbols such as monetary symbols ( Pound, Franc, Rupee, etc. ); special symbols ( Pi, &, @, etc. ); or graphic instruction binary chords (shaded, lightened, underlined, etc.) can be formed or produced according to the instructions illustrated in the table in FIG. 2L.

Because there are a total of eight binary keys or sensors, it is possible to form a total of 256 binary combinations ( $2*2*2*2*2*2*2*2 = 256$ ). Those combinations are summarized in the table illustrated in FIG. 2M. If activation of the shifting binary keys or sensors chord is employed, it offers the possibility of a secondary set of 255 unassigned eight bit binary chord groups which can be used for a multiplicity of modes, such as different size fonts, bold, italics, underline, highlight, etc., a feature which substantially expands the capability of the system 10.

In order to more fully understand the invention, FIGS. 3A-3C illustrate the manner in which certain specific letters are formed or produced. The lower case letter i is illustrated graphically in FIG. 3A. The first preferred left hand group 32 and the second preferred right hand group 44 positions, respectively, are shown in outline above the eight binary keys or sensors. The letter i, because it is a vowel, is simply formed or produced by the depression or activation of the second digit, the preferred middle digit 38 (LM) corresponding to the binary key or sensor 16 of the first set of four binary keys or sensors 12 which is shown by the blackened dot in FIG. 3A. This would, of course, correspond to the depression or activation of binary key or sensor 68 in the 8-dot braille alternative embodiment 60 illustrated in FIGS. 1D and 1E.

FIG. 3B illustrates the manner in which the lower case consonant binary chord r is formed or produced. This is, of course, formed or produced according to the table illustrated in FIG. 2C which shows that the first digit, the preferred ring digit 36 (LR) of the first preferred left hand group 32 depresses or activates binary key or sensor 14 (which otherwise would form the vowel o) in simultaneous combination with the index digit 48 (RI) of the second preferred right hand group 44 which depresses or activates binary key or sensor 26 of the second group of four binary keys or sensors 22.

The capital letter R is formed or produced as shown in the illustration of FIG. 3C and according to the instructions in the table of FIG. 2D. Again, the first digit, the preferred left ring digit 36 (LR) of the first preferred left hand group 32 depresses or activates binary key or sensor 14 (which would otherwise, by itself, produces the letter o) in simultaneous combination with the depression or activation of the thumb binary key or sensor 24 by the fifth digit, the preferred thumb digit 46 (RT) of the second right hand group 44 and the index digit binary key or sensor 26 by the sixth digit, the preferred index digit 48 (RI) of the second preferred right hand group 44.

The letters i, r and R can also be easily formed or produced on the alternative 8-dot braille system according to the table illustrated in FIG. 1D. and on the binary key or sensor arrangement in FIG. 1E. As shown in FIG. 3D, the letter i is formed or produced using the alternative 8-dot braille system illustrated in FIG. 1D by depressing or activating binary key or sensor 68 with the second digit, the preferred left middle finger 38 (LM). Similarly, the letter r is formed or produced by depressing or activating binary keys or sensors 70 and 74 with the first digit, the preferred left ring finger 36 (LR) and the sixth digit, the preferred right index finger 48 (RI). Lastly, the capital letter R is formed or produced by depressing or activating binary keys or sensors 70, 72 and 74 with the first digit, the preferred left ring finger 36 (LR) in simultaneous combination with the fifth



digit, the preferred right thumb digit 46 (RT) and the sixth digit, the preferred right index finger 48 (RI), respectively.

FIGS. 4A-4C illustrate, respectively, the manner in which the numbers 0, 9 and 23 are entered or produced. The number 0 is entered or produced, as shown in FIG. 4A, merely by the simultaneous depression or activation of all of the binary keys or sensors 24, 26, 28 and 30 of the second set 22 or by the preferred four digits 46, 48, 50 and 52 of the second preferred right hand group 44 along with none of the binary keys or sensors of the first set of four binary keys or sensors 12 or by the first preferred left hand group 32.

The number 9 is entered or produced by depressing or activating all the four binary keys or sensors 24, 26, 28 and 30 of the second set 22 by the preferred four digits 46, 48, 50 and 52 of the second preferred right hand group 44 along with depressing or activating the binary keys or sensors 14 and 20 of the first set of four binary keys or sensors 12 with the digits 36 (LR) and 42 (LT) of the first preferred left hand group 32 according to the instructions in the table of FIG. 2E.

As shown in FIG. 4C, the number 23 is formed or produced by entering or producing the number 2 and the number 3 in sequence. The number 2 is entered or produced by depressing or activating all of the four binary keys or sensors of the second set 22 along with the depression or activation of the binary key or sensor 16 by the preferred middle digit 38 (LM) of the first preferred left hand group 32. The operator then removes all digits from both sets of four binary keys or sensors 12 and 22 and then depresses or activates all binary keys or sensors of the second set 22 with the four digits of the second preferred right hand group 44 while depressing or activating binary keys or sensors 14 and 16 with the preferred ring digit 36 (LR) and middle digit 38 (LM) of the first preferred left hand group 32 to form the number 3. This will enter or produce the number 23 into the keyboard system 10.

The function F12 is entered or produced according to FIG. 5 and the instructions found in the table illustrated in FIG. 2G. Initially, the operator depresses or activates the binary keys or sensors 26, 28 and 30 with the index 48 (RI), middle 50 (RM) and ring 52 (RR) digits of the second preferred right hand group 44. Substantially simultaneously, the operator depresses or activates binary keys or sensors 18 and 20 of the first set of four binary keys or sensors 12 with the index 40 (LI) and thumb 42 (LT) digits of the first preferred left hand group 32. This is, of course, the reverse binary notation for the number 12.

The system 10 can use a variety of different keyboards, including some that are already on the market. For example, the one handed BAT chord keyboard, U. S. Patent # 5,642,108

described in the related art section of this specification can be employed simply by disabling the little digit keys used by fingers 34 and 54, and tying together the three thumb keys used by the left thumb 42 so they work as one binary key, and the same for the three thumb keys used by the right thumb 46. Other known keyboards can also be employed for the same purpose as long as information is forwarded to a word processor or computer according to the table summarized on FIG. 2M. The most convenient way to employ the improved keyboard system 10 is to provide an interface or software which translates the octal eight digit binary code into a standard computer code such as ASCII and extended ASCII or EBCDIC which a conventional computer will recognize. This can be done external to the computer through a hardwired interface or internal to the computer through an electronic interpreter or a software program according to the translation instructions in the table in FIG. 2M and according to techniques that are very well known to those of ordinary skill in the art.

In summary, the improved keyboard using an eight bit binary code data entry system 10 according to the preferred and alternative embodiment of the invention is relatively easy to learn and very easy to use, especially by handicapped and sight impaired individuals. The vowels, consonants and numbers are formed or produced in a unique and logical way that makes them easy to learn and remember and also quick to implement. Other features and functions of the invention achieve the same result.

While the invention has been described with reference to the preferred embodiment thereof, it will be appreciated by those of ordinary skill in the art that various modifications can be made to the system and method of the invention without departing from the spirit and scope of the invention as a whole.

A portion of this patent document contains material which is subject to copyright protection. The copyright owner has no objection to the facsimile reproduction by anyone of the patent document or the patent disclosure, as it appears in the Patent and Trademark Office patent files or records, but otherwise reserves all copyrights whatsoever.

CLAIM:

1. An eight bit binary code used as a data entry system for a binary eight key or sensor chordic keyboard consisting of:

a first set of four binary sensors for use by four digits of a first hand group; and, means for producing a vowel whenever at least one of said four binary sensors of said first set of four binary sensors is activated by a digit of said first hand group, combined with an unused second set of four binary key sensors for a second hand group.

2. The eight bit binary code used as a data entry system of claim 1 further comprising:

a said second set of four binary sensors for use by four digits of a second hand group, wherein activation of at least one of said binary sensors of said second set of four binary sensors by a digit of said second hand group in simultaneous combination with the desired consonant's preceding vowel representation produced on at least one of said four binary sensors of said first set of four binary sensors produces a consonant.

3. The eight bit binary code used as a data entry system of claim 1, wherein said first set of four binary sensors is located for use by four digits, the thumb, index, middle and ring digits of the said first hand group.

4. The eight bit binary code used as a data entry system of claim 2, wherein said second set of four binary sensors is located for use by four digits, the thumb, index, middle and ring digits of the said second hand group.

5. The eight bit binary code used as a data entry system of claim 3, wherein numbers are assigned binary abacus numeric values and are produced from left to right starting with the left most binary digit, the said ring digit of the said first hand group, as the lowest positive binary integer and progressing towards the said thumb digit of the said first hand group producing numbers in a reverse binary code fashion.

6. The eight bit binary code used as a data entry system of claim 5 wherein said data entry system is shifted to a numeric mode when the said four digits, the thumb, index, middle and ring digits of the said second hand group, activate all of the four binary sensors of said second set of four binary sensors, and wherein numbers are produced in accordance with claim 5, in a reverse binary fashion with the said ring, middle, index and thumb digits of the said first hand group activating or depressing said first set of four binary sensors.

7. The eight bit binary code used as a data entry system of claim 5 wherein said system is shifted to a numeric multifunction mode by the substantially simultaneous activation of the three highest binary valued binary sensors of said second set of four binary sensors by the said index, middle and ring digits of the said second hand group and wherein multifunction mode binary numbers are produced in a said reverse binary fashion with the said ring, middle, index and thumb digits of the said first hand group in accordance with claim 5.

8. The eight bit binary code used as a data entry system of claim 1 wherein the vowel u is produced by the substantially simultaneous activation of the two inner binary sensors of the said first set of four binary sensors by the said two inner middle and index digits of the said first hand group of four digits.

9. The eight bit binary code used as a data entry system of claim 1 wherein the vowel y is produced by the substantially simultaneous activation of the two outer binary sensors of the said first set of four binary sensors by the said outer ring and thumb digits of the said first hand group of four digits.

10. The eight bit binary code used as a data entry system of claim 2 wherein said eight sensor chordic binary keyboard comprises a said first set of four binary sensors and a said second set of four binary sensors arranged in two rows in a substantially parallel and mirror imaged vertical fashion simulating an 8-dot braille cell arrangement.

11. A method of producing eight bit binary data into an apparatus consisting of a first set of four binary sensors for use by a first hand group and a second set of four binary sensors for use by a second hand group, said method comprising the step of:

producing a vowel by activating at least one of the binary sensors of said first set of four sensors with at least one digit from said first hand group.

12. The method of claim 11 further comprising the step of:

producing a consonant by activating at least one of the said binary sensors of said second set of four binary sensors with at least one digit of said second hand group in simultaneous combination with the activation of at least one of the said binary sensors of said first set of four binary sensors that produces the consonant's preceding vowel entry with said first hand group.

13. The method of claim 11 wherein said first set of four binary sensors comprises four binary sensors for activation by the thumb, index, middle and ring digits of said first hand group and said first hand group comprises the left hand group.

14. The method of claim 12 wherein said second set of four binary sensors comprises four binary sensors for activation by the thumb, index, middle and ring digits of said second hand group and said second hand group comprises the right hand group.

15. The method of claim 14 further comprising the step of:

shifting into a numeric mode by activating all said four binary sensors of said second set of four binary sensors with the said thumb, index, middle and ring digits of the said second hand group.

16. The method of claim 15 wherein numbers are produced in said numeric mode on said first set of four binary sensors, from left to right, starting with the lowest and left most ring digit of the said first hand group as the lowest possible positive binary integer and progressing towards the right, producing binary numbers in a reverse binary fashion.

17. The method of claim 14 further comprising the step of:

shifting into a multifunction mode by activating the three highest possible binary value binary sensors of said second set of four binary sensors by the three highest possible positive binary integer digits, the index, middle and ring digits of the said second hand group, and then producing the binary numeric code for the specific numeric function desired by activating at least one binary sensor of said first set of four binary sensors with at least one digit of said first hand group.

18. The method of claim 11 further comprising the step of:

producing the vowel u by activating the two inner binary sensors of said first set of four binary sensors with the said middle and index digits of the said first hand group.

19. The method of claim 11 further comprising the step of:

producing the vowel y by activating the two outer binary sensors of said first set of four binary sensors with the said ring and thumb digits of the said first hand group.

20. The method of claim 12 wherein said first and second set of four binary sensors

comprises an 8-dot braille cell arrangement in which said first set of four binary sensors and said second set of four binary sensors are arranged in two substantially vertical rows, where the lowest possible positive binary integer is located on the bottom of the first left set of the 8-dot braille cell, and where the highest possible positive binary integer is located on the bottom of the second right set of the 8-dot braille cell.

21. The system of claim 1 wherein said first set of four binary sensors produces

vowels, when used in simultaneous combination with an unused second set of four binary sensors, produces a logical four left bit combined with a four right bit readable eight bit binary code arrangement operating system.

22. The system of claim 2 wherein said first set of four binary sensors produces

vowels, and said second set of four binary sensors produces consonants, when used in simultaneous combination with the consonants preceding vowel representation produced on said first set of four binary sensors, producing a logical four left bit combined with a four right bit readable eight bit binary code arrangement operating system.

1/37

FIG. 1A

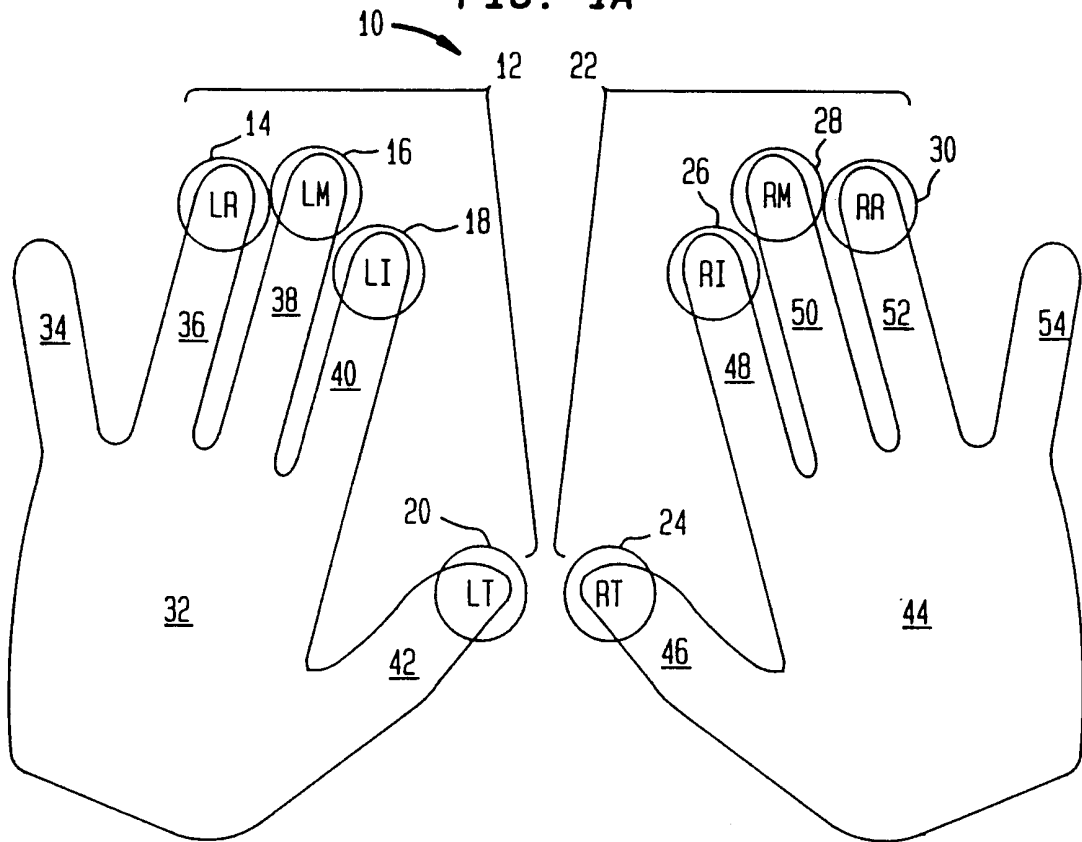
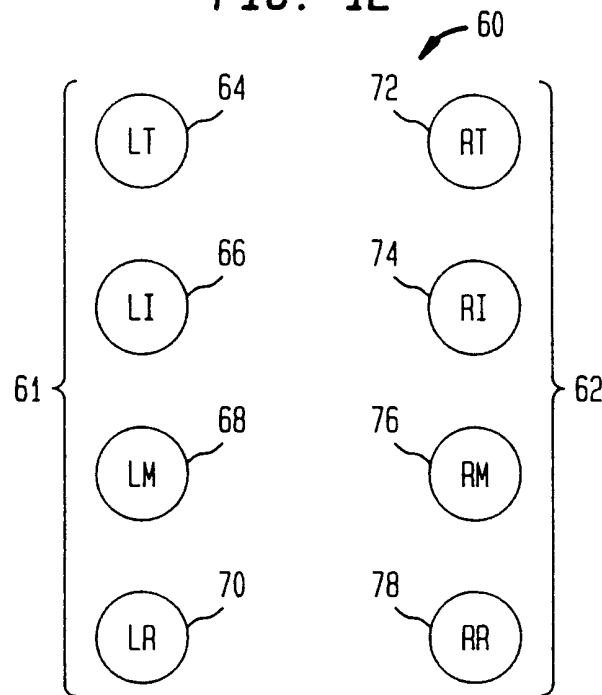


FIG. 1E



2/37

FIG. 1B

INPUT DIGIT TABLE

<u>HAND</u>	<u>DIGIT</u>	<u>ABBREVIATION</u>	<u>OCTAL #</u>
LEFT	Ring Finger	LR	1
	Middle Finger	LM	2
	Index Finger	LI	4
	Thumb	LT	8
RIGHT	Thumb	RT	16
	Index Finger	RI	32
	Middle Finger	RM	64
	Ring Finger	RR	128

FIG. 1C

FINGER-OCTAL NUMBER TABLE

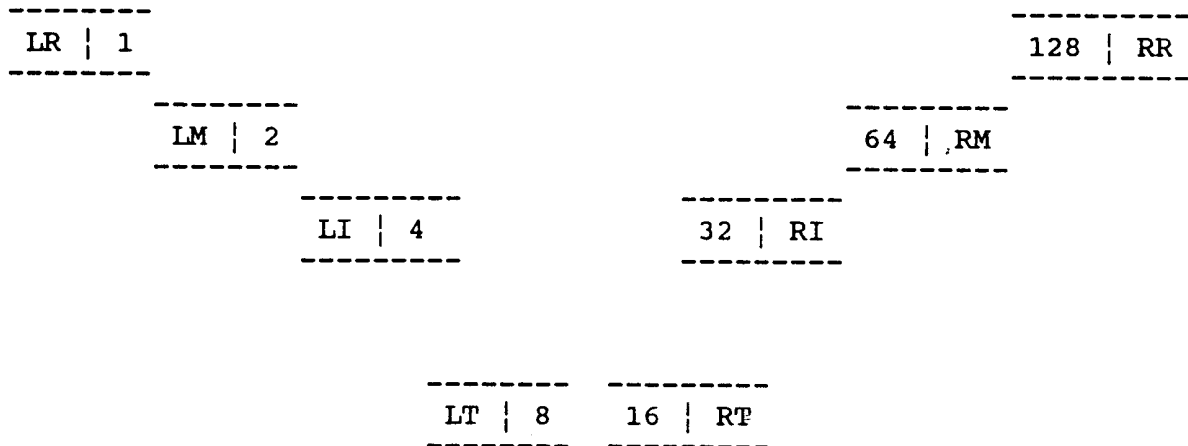


FIG. 1D

8-DOT BRAILLE ORGANIZATION

(8)	LT	.	.	RT	(16)
(4)	LI	.	.	RI	(32)
(2)	LM	.	.	RM	(64)
(1)	LR	.	.	RR	(128)



3/37

FIG. 1F

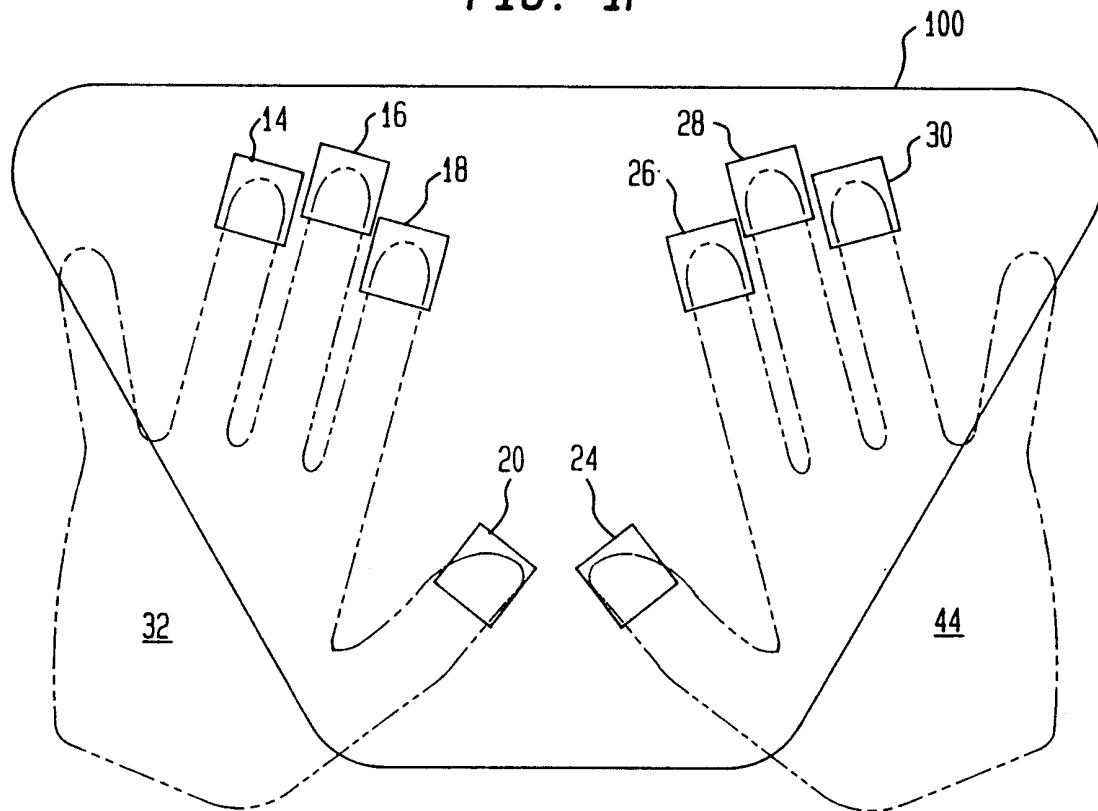
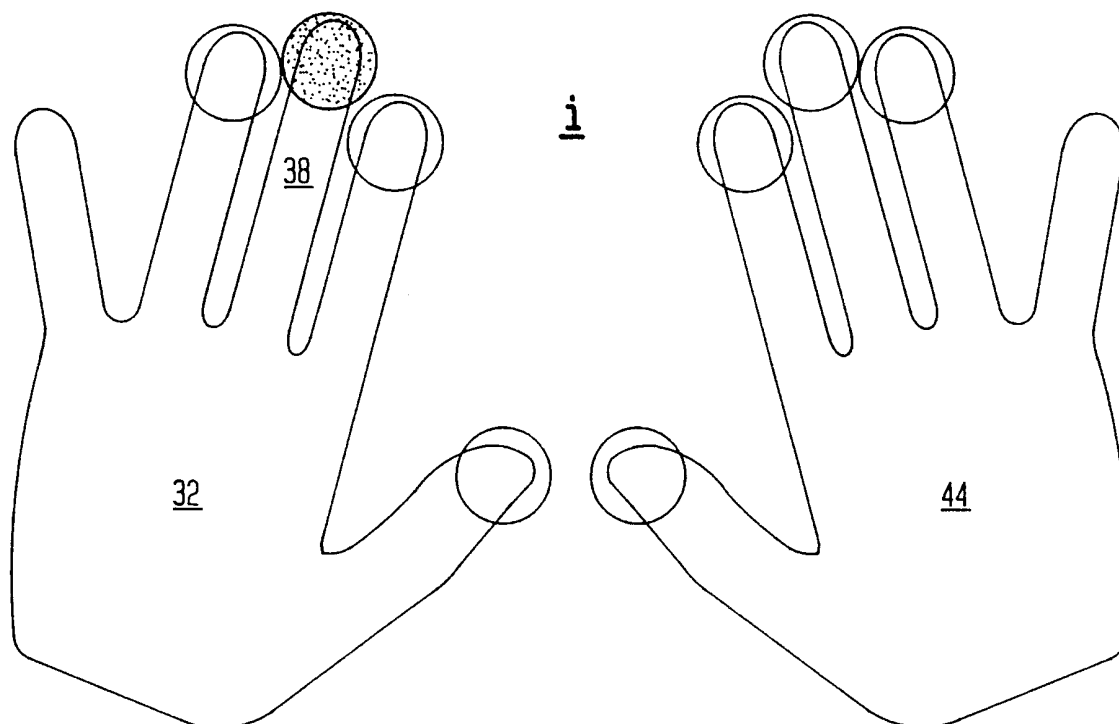


FIG. 3A



4/37

FIG. 2A

ALPHABET CHORDS

<u>VOWEL</u>	<u>REVERSE</u>	<u>BINARY #</u>	<u>OCTAL #</u>	<u>BINARY #</u>	<u>KEYBOARD ENTRY</u>
a	0001	0000	8	16	LT
e	0010	0000	4	32	LI
i	0100	0000	2	64	LM
o	1000	0000	1	128	LR
u	0110	0000	6	96	LMI
y	1001	0000	9	144	LRT

FIG. 2B

VOWEL CONSONANT GROUPINGS

a	e	i	o	u	y
b	f	j	p	v	
c	g	k	q	w	z
d	h	l	r	x	
		m	s		
		n	t		

FIG. 2C

LOWER CASE LETTER TABLE

<u>LETTER</u>	<u>REVERSE</u>	<u>BINARY #</u>	<u>OCTAL #</u>	<u>BINARY #</u>	<u>KEYBOARD ENTRY</u>
a	0001	0000	8	16	LT
b	0001	0100	40	20	LT RI
c	0001	0010	72	18	LT RM
d	0001	0001	136	17	LT RR
e	0010	0000	4	32	LI
f	0010	0100	36	36	LI RI
g	0010	0010	68	34	LI RM
h	0010	0001	132	33	LI RR
i	0100	0000	2	64	LM
j	0100	0110	98	70	LM RIM
k	0100	0011	194	67	LM RMR
l	0100	0100	34	68	LM RI
m	0100	0010	66	66	LM RM
n	0100	0001	130	65	LM RR
o	1000	0000	1	128	LR
p	1000	0110	97	134	LR RIM
q	1000	0011	193	131	LR RMR
r	1000	0100	33	132	LR RI
s	1000	0010	65	130	LR RM
t	1000	0001	129	129	LR RR
u	0110	0000	6	96	LMI
v	0110	0100	38	100	LMI RI
w	0110	0010	70	98	LMI RM
x	0110	0001	134	97	LMI RR
y	1001	0000	9	144	LRT
z	1001	0100	41	148	LRT RI

5/37

FIG. 2D

UPPER CASE LETTER TABLE

<u>LETTER</u>	<u>REVERSE</u>	<u>BINARY #</u>	<u>OCTAL #</u>	<u>BINARY #</u>	<u>KEYBOARD ENTRY</u>	
Sp	0000	1000	16	8		RT
A	0001	1000	24	24	LT	RT
B	0001	1100	56	28	LT	RTI
C	0001	1010	88	26	LT	RTM
D	0001	1001	152	25	LT	RTR
E	0010	1000	20	40	LI	RT
F	0010	1100	52	44	LI	RTI
G	0010	1010	84	42	LI	RTM
H	0010	1001	148	41	LI	RTR
I	0100	1000	18	72	LM	RT
J	0100	1110	114	78	LM	RTIM
K	0100	1011	210	75	LM	RTMR
L	0100	1100	50	76	LM	RTI
M	0100	1010	82	74	LM	RTM
N	0100	1001	146	73	LM	RTR
O	1000	1000	17	136	LR	RT
P	1000	1110	113	142	LR	RTIM
Q	1000	1011	209	139	LR	RTMR
R	1000	1100	49	140	LR	RTI
S	1000	1010	81	138	LR	RTM
T	1000	1001	145	137	LR	RTR
U	0110	1000	22	104	LMI	RT
V	0110	1100	54	108	LMI	RTI
W	0110	1010	86	106	LMI	RTM
X	0110	1001	150	105	LMI	RTR
Y	1001	1000	25	152	LRT	RT
Z	1001	1100	57	156	LRT	RTI

PUNCTUATION

.	0000	0100	32	4		RI
,	0000	0001	128	1		RR
?	0000	1110	112	14		RTIM
!	0000	0010	64	2		RM
:	0000	0110	96	6		RIM
;	0000	0101	160	5		RIR
'	0000	1001	144	9		RTR
"	0000	1101	176	13		RTIR

FIG. 2E

NUMBER CHORD TABLE

<u>NUMBER</u>	<u>REVERSE</u>	<u>BINARY #</u>	<u>OCTAL #</u>	<u>BINARY #</u>	<u>KEYBOARD ENTRY</u>	
0	0000	1111	240	15		RTIMR
1	1000	1111	241	143	LR	RTIMR
2	0100	1111	242	79	LM	RTIMR
3	1100	1111	243	207	LRM	RTIMR
4	0010	1111	244	47	LI	RTIMR
5	1010	1111	245	175	LRI	RTIMR
6	0110	1111	246	111	LMI	RTIMR
7	1110	1111	247	239	LRMI	RTIMR
8	0001	1111	248	31	LT	RTIMR
9	1001	1111	249	159	LRT	RTIMR

6/37

FIG. 2F

COMMON MATH FUNCTION CHORD TABLE

<u>MATH FUNCTION</u>	<u>REVERSE BINARY #</u>	<u>OCTAL #</u>	<u>BINARY #</u>	<u>KEYBOARD ENTRY</u>
+ 10	0101 1111	250	95	LMT RTIMR
x 11	1101 1111	251	223	LRMT RTIMR
- 12	0011 1111	252	63	LIT RTIMR
: 13	1011 1111	253	191	LRIT RTIMR
= 14	0111 1111	254	127	LMIT RTIMR

FIG. 2G

FUNCTION CHORD TABLE

<u>FUNCTION #</u>	<u>REVERSE BINARY #</u>	<u>OCTAL #</u>	<u>BINARY #</u>	<u>KEYBOARD ENTRY</u>
F1	1000 0111	225	135	LR RIMR
F2	0100 0111	226	71	LM RIMR
F3	1100 0111	227	199	LRM RIMR
F4	0010 0111	228	39	LI RIMR
F5	1010 0111	229	167	LRI RIMR
F6	0110 0111	230	103	LMI RIMR
F7	1110 0111	231	231	LRMI RIMR
F8	0001 0111	232	23	LT RIMR
F9	1001 0111	233	151	LRT RIMR
F10	0101 0111	234	87	LMT RIMR
F11	1101 0111	235	215	LRMT RIMR
F12	0011 0111	236	55	LIT RIMR
F13	1011 0111	237	183	LRIT RIMR
F14	0111 0111	238	119	LMIT RIMR
F15	1111 0111	239	247	LRMIT RIMR

FIG. 2H

CONTAINMENT CHORD TABLE

<u>CONTAINMENT CHORD</u>	<u>REVERSE BINARY #</u>	<u>OCTAL #</u>	<u>BINARY #</u>	<u>KEYBOARD ENTRY</u>
(	0101 0000	10	80	LMT
)	0000 1010	80	10	RTM
[	1101 0000	11	208	LRMT
]	0000 1011	208	11	RTMR
{	1011 0001	141	177	LRIT RR
}	1000 1101	177	141	LR RTIR
<	0010 0101	164	37	LI RIR
>	1010 0100	37	164	LRI RI
«	0111 1100	62	124	LMIT RTI
»	0011 1110	124	62	LIT RTIM

7/37

FIG. 2I

<u>MOVEMENT CHORDS</u>					
<u>MOVEMENT CHORD</u>	<u>REVERSE</u>	<u>BINARY #</u>	<u>OCTAL #</u>	<u>BINARY #</u>	<u>KEYBOARD ENTRY</u>
Home	1111	0110	111	246	LRMIT RIM
Cursor Up	1111	1000	31	248	LRMIT RT
Cursor Down	1111	0001	143	241	LRMIT RR
Cursor Left	1111	1100	63	252	LRMIT RTI
Cursor Rt	1111	0011	207	243	LRMIT RMR
Cursor	0011	0011	204	51	LIT RMR
Tab Right	0000	0011	192	3	RMR
Page Up	0111	1000	30	120	LMIT RT
Page Down	0111	0001	142	113	LMIT RR

OPERATING CHORDS

FIG. 2J-1

<u>OPERATING INSTRUCTION</u>	<u>REVERSE</u>	<u>BINARY #</u>	<u>OCTAL #</u>	<u>BINARY #</u>	<u>KEYBOARD ENTRY</u>
Backspace	1110	0000	7	224	LRMI
(NO) Neg. Acknowledge	1011	0000	13	176	LRIT
(YES) Acknowledge	0111	0000	14	112	LMIT
Delete	1111	0000	15	240	LRMIT
Space	0000	1000	16	8	RT
Escape	1100	1000	19	200	LRM RT
Data link escape	1101	1000	27	216	LRMT RT
(U)nit Separator	1011	1000	29	184	LRIT RT
Reset	1101	0100	43	212	LRMT RI
GOTO	1011	0100	45	180	LRIT RI
MOVE	0111	0100	46	116	LMIT RI
Control	1111	0100	47	244	LRMIT RI
Break	0000	1100	48	12	RTI
Form Feed	0011	1100	60	60	LIT RTI
(R)ecord Separator	1011	1100	61	188	LRIT RTI
Horizontal Tab	0111	0010	78	114	LMIT RM
Vertical Tab	1111	0010	79	242	LRMIT RM
(S)tart of Heading	1010	1010	85	170	LRI RTM
(S)tart of Text	1110	1010	87	234	LRMI RTM
End of Text	1001	1010	89	154	LRT RTM
End of Transmit	0101	1010	90	90	LMT RTM
End trans. block	1101	1010	91	218	LRMT RTM

8/37

FIG. 2J-2

End of Medium	0011	1010	92	58	LIT	RTM
(G)roup Separator	1011	1010	93	186	LRIT	RTM
End	0111	1010	94	122	LMIT	RTM
Cancel	1111	1010	95	250	LRMIT	RTM
Print Line	1010	0110	101	166	LRI	RIM
Copy	0110	0110	102	102	LMI	RIM
Print	0101	0110	106	86	LMT	RIM
Print Screen	0011	0110	108	54	LIT	RIM
HOME	1111	0110	111	246	LRMIT	RIM
Inquiry	0010	1110	116	46	LI	RTIM
Line Feed	0111	1110	126	126	LMIT	RTIM
HELP	1111	1110	127	254	LRMIT	RTIM
SUBstitution	1111	1001	159	249	LRMIT	RTR
Synchronous Idle	1010	0101	165	165	LRI	RIR
Shift Out	1111	0101	175	245	LRMIT	RIR
Figures						
Shift	1100	1101	179	205	LRM	RTIR
Scroll Lock	1011	1101	189	189	LRIT	RTIR
Shift In	1111	1101	191	253	LRMIT	RTIR
Alternate Carriage	1111	1011	223	251	LRMIT	RTMR
Return	0000	0111	224	7		RIMR
Insert	1111	1111	255	255	LRMIT	RTIMR

9/37

FIG. 2K

FOREIGN VOWELS/CONSONANTS

FOREIGN TERM	REVERSE	BINARY #	OCTAL #	BINARY #	KEYBOARD ENTRY
æ	0011	0000	12	48	LIT
Æ	0011	1000	28	56	LIT RT
ñ	0100	0101	162	69	LM RIR
Ñ	0100	1101	178	77	LM RTIR
oe	1010	0000	5	116	LRI
OE	1010	1000	21	168	LRI RT
ç	0001	0011	200	19	LT RMR
Ç	0001	1011	216	27	LT RTMR
^	0010	1011	212	43	LI RTMR
â	1110	1011	215	235	LRMI RTMR
ê	1101	1011	219	219	LRMT RTMR
î	1011	1011	221	187	LRIT RTMR
ô	0111	1011	222	123	LMIT RTMR
û	1001	1011	217	155	LRT RTMR
`	0010	0011	196	35	LI RMR
à	1110	0011	199	227	LRMI RMR
è	1101	0011	203	211	LRMT RMR
ì	1011	0011	205	179	LRIT RMR
ò	0111	0011	206	115	LMIT RMR
ù	1001	0011	201	147	LRT RMR
´	0010	0110	100	38	LI RIM
á	1110	0110	103	230	LRMI RIM
é	1101	0110	107	214	LRMT RIM
É	1101	1110	123	222	LRMT RTIM
í	1011	0110	109	182	LRIT RIM
ó	0111	0110	110	118	LMIT RIM
ú	1001	0110	105	150	LRT RIM
¨	0011	0101	172	53	LIT RIR
ä	1110	0101	167	229	LRMI RIR
Ä	1110	1101	183	237	LRMI RTIR
ë	1101	0101	171	213	LRMT RIR
ï	1011	0101	173	181	LRIT RIR
ö	0111	0101	174	117	LMIT RIR
Ö	0111	1101	190	125	LMIT RTIR
ü	1001	0101	169	149	LRT RIR
Ü	1001	1101	185	157	LRT RTIR
ÿ	0110	0101	166	101	LMI RIR
ß	0101	0101	170	85	LMT RIR

10/37

FIG. 2L-1

MONETARY CHORDS

<u>SYMBOL</u>	<u>REVERSE</u>	<u>BINARY #</u>	<u>OCTAL #</u>	<u>BINARY #</u>	<u>KEYBOARD ENTRY</u>
*	1100	0000	3	192	LRM
¥ (Y)en	1100	1000	19	200	LRM RT
f (f)ranc	1100	0100	35	196	LRM RI
₹ (R)upee	1100	1100	51	204	LRM RTI
¢ (c)ent	1100	0010	67	194	LRM RM
\$ (S)	1100	1010	83	202	LRM RTM
₹	1100	0110	99	198	LRM RIM
£ (P)ound	1100	1110	115	206	LRM RTIM
(E)scape	1100	1001	147	201	LRM RTR
Fig. Shift	1100	1101	179	205	LRM RTIR
#	1100	0011	195	195	LRM RMR

SYMBOL CHORDS

& (N)	1110	1001	151	233	LRMI RTR
π Pi	1001	1001	153	153	LRT RTR
² Squared	0101	1001	154	89	LMT RTR
· Multiply	1101	1001	155	217	LRMT RTR
° Degree	0011	1001	156	57	LIT RTR
■ Square	1011	1001	157	185	LRIT RTR
· Spot	0111	1001	158	121	LMIT RTR
©	0001	1101	184	29	LT RTIR
à	0001	0110	104	22	LT RIM
À	0001	1110	120	30	LT RTIM
§ Section	0101	0100	42	84	LMT RI
μ Micro	0110	0011	198	99	LMI RMR

GRAPHIC CHORDS

(c)hord 1					
┌	1001	0010	73	146	LRT RM
(c)hord 2					
└	0101	0010	74	82	LMT RM
(c)hord 3					
└┐	1101	0010	75	210	LRMT RM
(c)hord 4					
└┐	0011	0010	76	50	LIT RM
(c)hord 5					
—	1011	0010	77	178	LRIT RM
Vert. line	1110	0010	71	226	LRMI RM
Light (B)ox	░	1010	1100	53	LRI RTI
Dark (B)ox	▒	1110	1100	55	LRMI RTI
Shaded (B)ox	▓	1101	1100	59	LRMT RTI
Black (B)ox	■	1110	1110	119	LRMI RTIM
Top ½ Black	▀	0101	1000	26	LMT RT
Bottom ½ Black	▁	1010	0001	133	LRI RR
Left ½ Black	▂	0011	1101	188	LIT RTIR
Right ½ Black	▃	1100	1011	211	LRM RTMI



11/37

FIG. 2L-2

Underline	1110	1000	23	232	LRMI	RT
\	1110	0100	39	228	LRMI	RI
	1110	0010	71	226	LRMI	RM
/	1110	0001	135	225	LRMI	RR

12/37

FIG. 2M-1

0 (NULL) CHORD GROUP (0)

<u>OCTAL #</u>	<u>BINARY #</u>	<u>REVERSE BINARY #</u>	<u>ASCII EQUIVALENT</u>
0	0	0000 0000	Null (0)
1	128	1000 0000	o (111)
2	64	0100 0000	i (105)
3	192	1100 0000	* (42)
4	32	0010 0000	e (101)
5	160	1010 0000	oe
6	96	0110 0000	u (117)
7	224	1110 0000	Backspace (8)
8	16	0001 0000	a (97)
9	144	1001 0000	y (121)
10	80	0101 0000	( (40)
11	208	1101 0000	[ (91)
12	48	0011 0000	æ (145)
13	176	1011 0000	(NO) Neg.
14	112	0111 0000	Acknowledge (21) (YES)
15	240	1111 0000	Acknowledge (6) Delete
<u>1ST CHORD GROUP (16)</u>			
16	8	0000 1000	Space (32)
17	136	1000 1000	O (79)
18	72	0100 1000	I (73)
19	200	1100 1000	¥ Yen (157)
20	40	0010 1000	E (69)
21	168	1010 1000	OE
22	104	0110 1000	U (85)
23	232	1110 1000	Underline (95)
24	24	0001 1000	A (65)
25	152	1001 1000	Y (89)
26	88	0101 1000	■ (223)
27	216	1101 1000	Data link escape (16)
28	56	0011 1000	Æ (146)
29	184	1011 1000	Unit Separator (31)
30	120	0111 1000	Page Up
31	248	1111 1000	Cursor Up
<u>2ND CHORD GROUP (32)</u>			
32	4	0000 0100	. (46)
33	132	1000 0100	r (114)
34	68	0100 0100	l (108)
35	196	1100 0100	f (159)
36	36	0010 0100	f (102)
37	164	1010 0100	> (62)
38	100	0110 0100	v (118)
39	228	1110 0100	\ (92)
40	20	0001 0100	b (98)
41	148	1001 0100	z (122)
42	84	0101 0100	§ Section Symbol
43	212	1101 0100	Reset
44	52	0011 0100	Audible (b)ell (7)
45	180	1011 0100	GOTO
46	116	0111 0100	MOVE
47	244	1111 0100	Control

13/37

FIG. 2M-2

3RD CHORD GROUP (48)

48	12	0000	1100	Break
49	140	1000	1100	R (82)
50	76	0100	1100	L (76)
51	204	1100	1100	R (158)
52	44	0010	1100	F (70)
53	172	1010	1100	⋮ (176)
54	108	0110	1100	V (86)
55	236	1110	1100	⋮ (178)
56	28	0001	1100	B (66)
57	156	1001	1100	Z (90)
58	92	0101	1100	± (241)
59	220	1101	1100	⋮ (177)
60	60	0011	1100	Form Feed (12)
61	188	1011	1100	Record Separator (30)
62	124	0111	1100	“ (174)
63	252	1111	1100	Cursor Left

4TH CHORD GROUP (64)

64	2	0000	0010	! (33)
65	130	1000	0010	s (115)
66	66	0100	0010	m (109)
67	194	1100	0010	¢ (155)
68	34	0010	0010	g (103)
69	162	1010	0010	i (173)
70	98	0110	0010	w (119)
71	226	1110	0010	(179)
72	18	0001	0010	c (99)
73	146	1001	0010	r (218)
74	82	0101	0010	] (191)
75	210	1101	0010	] (192)
76	50	0011	0010	↓ (217)
77	178	1011	0010	- (196)
78	114	0111	0010	Horizontal Tab (9)
79	242	1111	0010	Vertical Tab (11)

5TH CHORD GROUP (80)

80	10	0000	1010	) (41)
81	138	1000	1010	S (83)
82	74	0100	1010	M (77)
83	202	1100	1010	\$ (36)
84	42	0010	1010	G (71)
85	170	1010	1010	Start of Heading (1)
86	106	0110	1010	W (87)
87	234	1110	1010	Start of Text (2)
88	26	0001	1010	C (67)
89	154	1001	1010	End of Text (3)
90	90	0101	1010	End of Transmit (4)
91	218	1101	1010	End trans. block (23)
92	58	0011	1010	End of Medium (25)
93	186	1011	1010	Group Separator (29)
94	122	0111	1010	End
95	250	1111	1010	Cancel (24)

14/37

FIG. 2M-3

6TH CHORD GROUP (96)

96	6	0000	0110	:	(58)
97	134	1000	0110	P	(112)
98	70	0100	0110	j	(106)
99	198	1100	0110	%	(37)
100	38	0010	0110	,	
101	166	1010	0110	Print Line	
				(Braille)	
102	102	0110	0110	Copy	
103	230	1110	0110	á	(160)
104	22	0001	0110	á	(134)
105	150	1001	0110	ú	(163)
106	86	0101	0110	Print	
107	214	1101	0110	é	(130)
108	54	0011	0110	Print Screen	
109	182	1011	0110	i	(161)
110	118	0111	0110	ó	(162)
111	246	1111	0110	HOME	

7TH CHORD GROUP (112)

112	14	0000	1110	?	(63)
113	142	1000	1110	P	(80)
114	78	0100	1110	J	(74)
115	206	1100	1110	f	(156)
116	46	0010	1110	Enquiry	(5)
117	174	1010	1110	¿	(168)
118	110	0110	1110	void 1	
119	238	1110	1110	■	(219)
120	30	0001	1110	À	(143)
121	158	1001	1110	void 2	
122	94	0101	1110	void 3	
123	222	1101	1110	È	(144)
124	62	0011	1110	»	(175)
125	190	1011	1110	≡	(240)
126	126	0111	1110	Line Feed	(10)
127	254	1111	1110	HELP	

8TH CHORD GROUP (128)

128	1	0000	0001	,	(44)
129	129	1000	0001	t	(116)
130	65	0100	0001	n	(110)
131	193	1100	0001	void 4	
132	33	0010	0001	h	(104)
133	161	1010	0001	■	(220)
134	97	0110	0001	x	(120)
135	225	1110	0001	/	(47)
136	17	0001	0001	d	(100)
137	145	1001	0001	Device	
				Control 1	(17)
138	81	0101	0001	Device	
				Control 2	(18)
139	209	1101	0001	Device	
				Control 3	(19)
140	49	0011	0001	Device	
				Control 4	(20)
141	177	1011	0001	(	(123)
142	113	0111	0001	Page Down	
143	241	1111	0001	Cursor Down	

15/37

## FIG. 2M-4

9TH CHORD GROUP (144)

144	9	0000	1001	' (39)
145	137	1000	1001	T (84)
146	73	0100	1001	N (78)
147	201	1100	1001	Escape (27)
148	41	0010	1001	H (72)
149	169	1010	1001	void 5
150	105	0110	1001	X (88)
151	233	1110	1001	& (38)
152	25	0001	1001	D (68)
153	153	1001	1001	$\pi$ Pi (227)
154	89	0101	1001	' Squared (253)
155	217	1101	1001	· Multiply (250)
156	57	0011	1001	· degree (248)
157	185	1011	1001	■ Square (254)
158	121	0111	1001	· Spot (249)
159	249	1111	1001	SUBStitution (26)

10TH CHORD GROUP (160)

160	5	0000	0101	; (59)
161	133	1000	0101	◻ (167)
162	69	0100	0101	$\bar{n}$ (164)
163	197	1100	0101	$\leq$ (243)
164	37	0010	0101	< (60)
165	165	1010	0101	Synchronous Idle (22)
166	101	0110	0101	ÿ (152)
167	229	1110	0101	ä (132)
168	21	0001	0101	◻ (166)
169	149	1001	0101	ü (129)
170	85	0101	0101	ß (ss) German (225)
171	213	1101	0101	è (137)
172	53	0011	0101	..
173	181	1011	0101	ï (139)
174	117	0111	0101	ö (148)
175	245	1111	0101	Shift Out (14)

11TH CHORD GROUP (176)

176	13	0000	1101	" (34)
177	141	1000	1101	} (125)
178	77	0100	1101	N (165)
179	205	1100	1101	Figures Shift (28)
180	45	0010	1101	~ (126)
181	173	1010	1101	void 6
182	109	0110	1101	≈ (247)
183	237	1110	1101	Ä (142)
184	29	0001	1101	@ (64)
185	157	1001	1101	Û (154)
186	93	0101	1101	void 7
187	221	1101	1101	void 8
188	61	0011	1101	█ (221)
189	189	1011	1101	Scroll Lock
190	125	0111	1101	Ö (153)
191	253	1111	1101	Shift In (15)

16/37

## FIG. 2M-5

12TH CHORD GROUP (192)

192	3	0000	0011	Cursor Right (Tab)
193	131	1000	0011	q (113)
194	67	0100	0011	k (107)
195	195	1100	0011	# (35)
196	35	0010	0011	` (96)
197	163	1010	0011	≥ (242)
198	99	0110	0011	μ Micro (230)
199	227	1110	0011	à (133)
200	19	0001	0011	ç (135)
201	147	1001	0011	û (151)
202	83	0101	0011	void 9
203	211	1101	0011	è (138)
204	51	0011	0011	Cursor
205	179	1011	0011	ì (141)
206	115	0111	0011	ò (149)
207	243	1111	0011	Cursor Right

13TH CHORD GROUP (208)

208	11	0000	1011	] (93)
209	139	1000	1011	Q (81)
210	75	0100	1011	K (75)
211	203	1100	1011	█ (222)
212	43	0010	1011	^ (94)
213	171	1010	1011	void 10
214	107	0110	1011	void 11
215	235	1110	1011	â (131)
216	27	0001	1011	Ç (128)
217	155	1001	1011	û (150)
218	91	0101	1011	¼ (171)
219	219	1101	1011	ê (136)
220	59	0011	1011	¼ (172)
221	187	1011	1011	î (140)
222	123	0111	1011	ô (147)
223	251	1111	1011	Alternate

14TH CHORD GROUP (224)

224	7	0000	0111	(Enter) Carriage Return (13)
225	135	1000	0111	F1
226	71	0100	0111	F2
227	199	1100	0111	F3
228	39	0010	0111	F4
229	167	1010	0111	F5
230	103	0110	0111	F6
231	231	1110	0111	F7
232	23	0001	0111	F8
233	151	1001	0111	F9
234	87	0101	0111	F10
235	215	1101	0111	F11
236	55	0011	0111	F12
237	183	1011	0111	F13
238	119	0111	0111	F14
239	247	1111	0111	F15

FIG. 2M-6

15TH CHORD GROUP (240)

240	15	0000	1111	0	(48)
241	143	1000	1111	1	(49)
242	79	0100	1111	2	(50)
243	207	1100	1111	3	(51)
244	47	0010	1111	4	(52)
245	175	1010	1111	5	(53)
246	111	0110	1111	6	(54)
247	239	1110	1111	7	(55)
248	31	0001	1111	8	(56)
249	159	1001	1111	9	(57)
250	95	0101	1111	+	(43)
251	223	1101	1111	x	(Multiply)
252	63	0011	1111	-	(45)
253	191	1011	1111	+	(246) Division Symbol
254	127	0111	1111	=	(61)
255	255	1111	1111		Insert

FIG. 3B

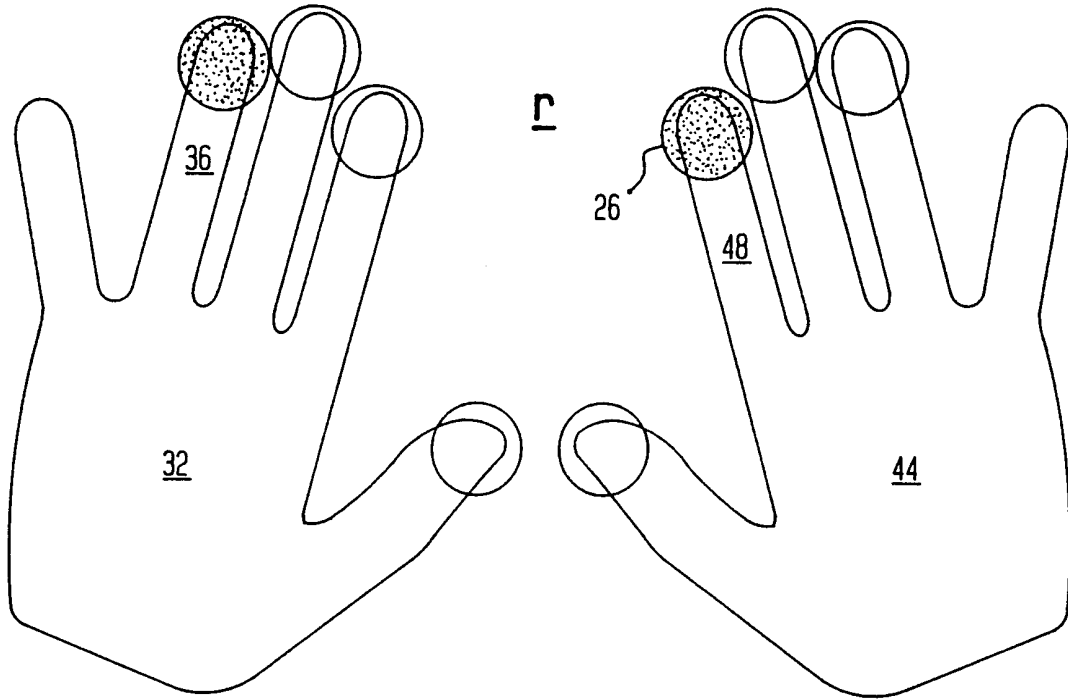


FIG. 3C

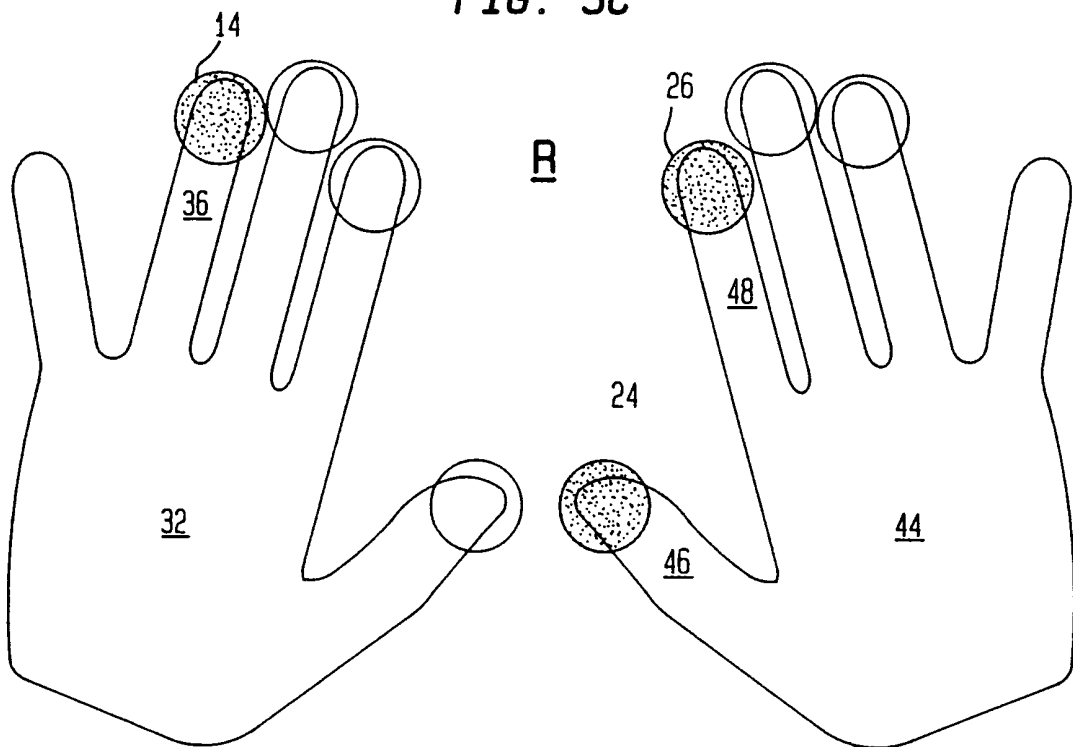




FIG. 3D

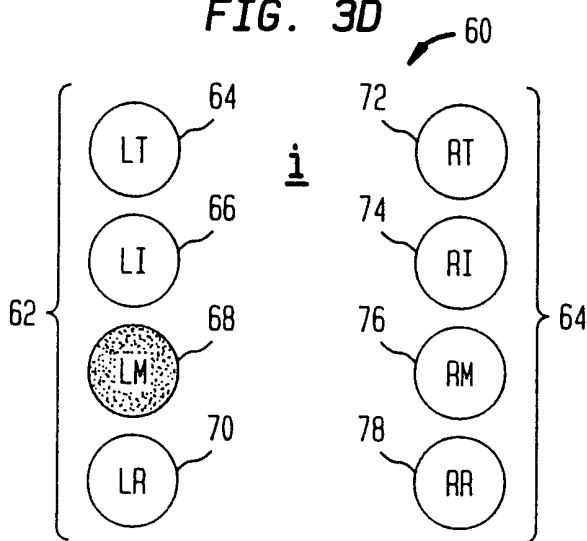


FIG. 3E

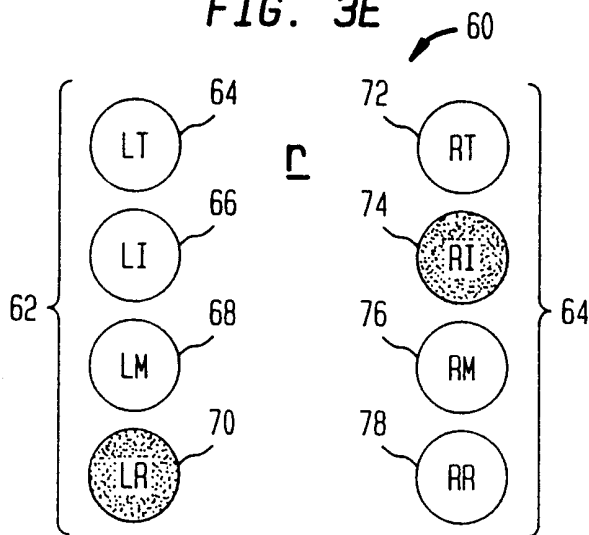


FIG. 3F

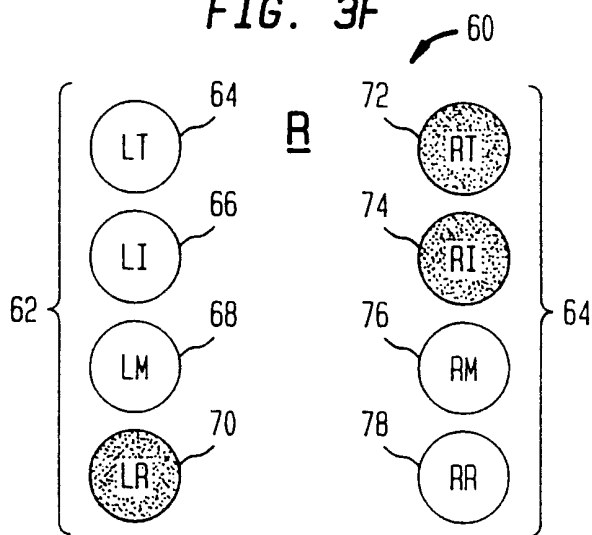


FIG. 4A

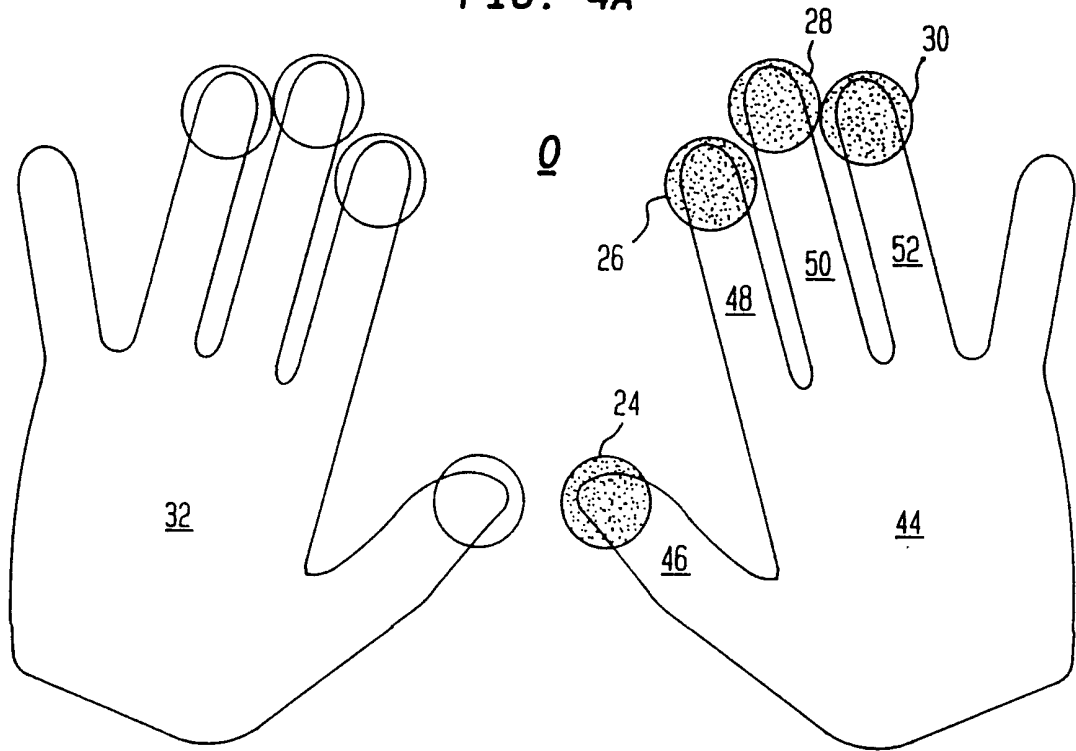
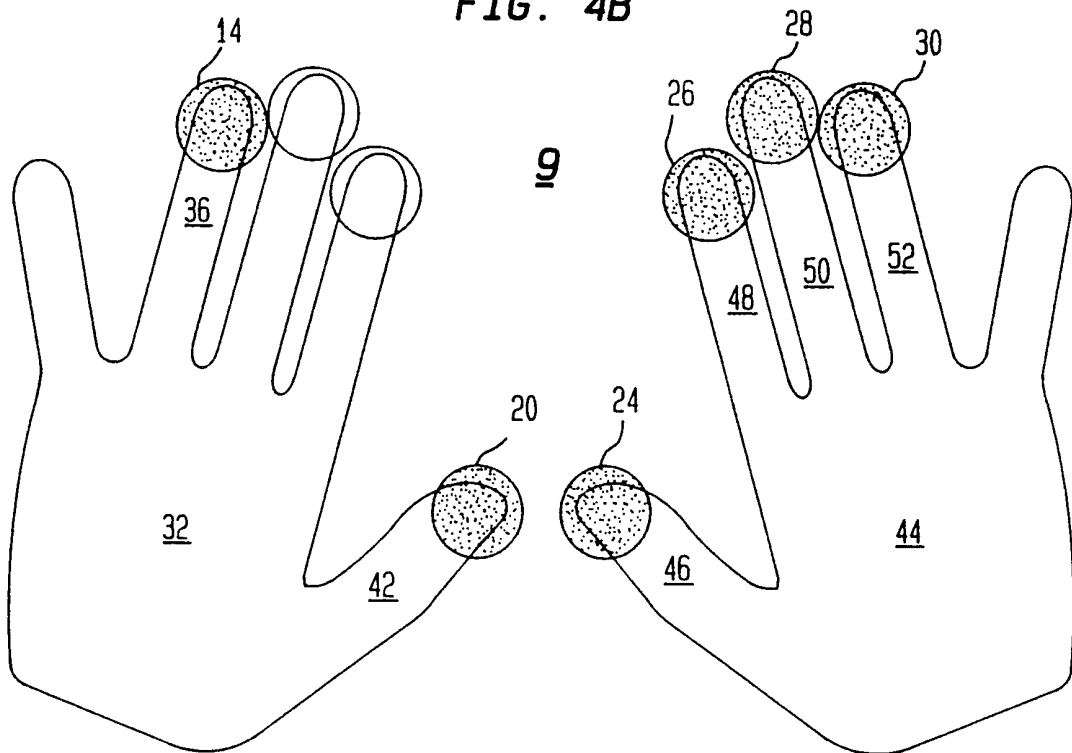


FIG. 4B



21/37

FIG. 4C

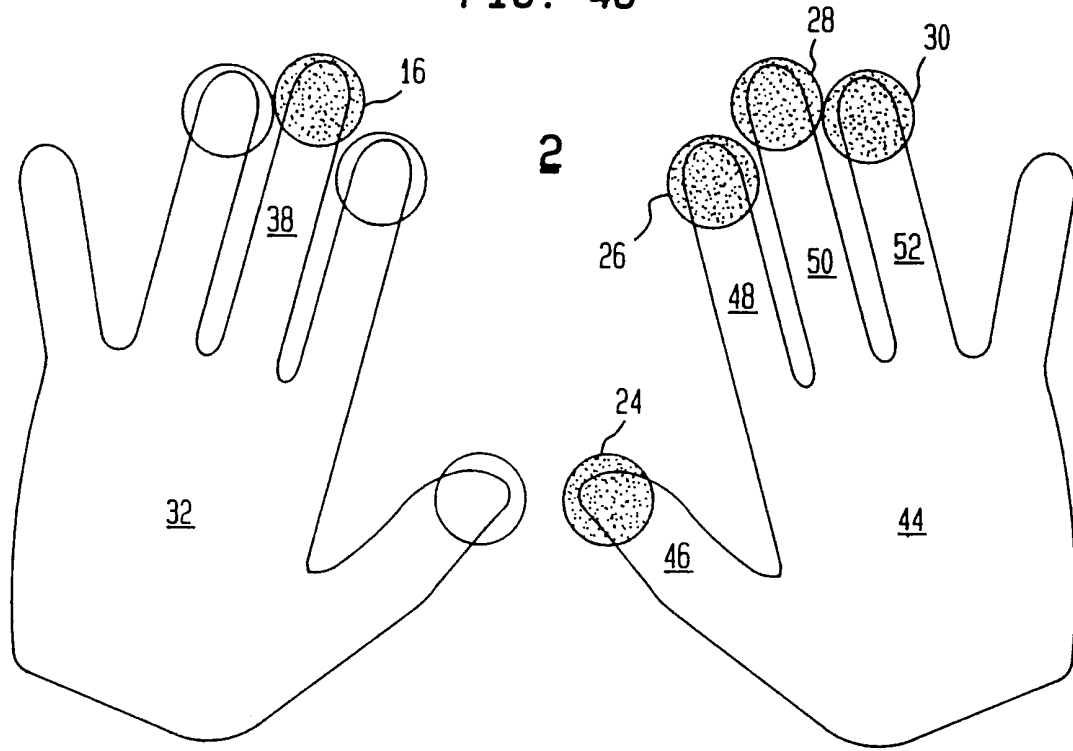
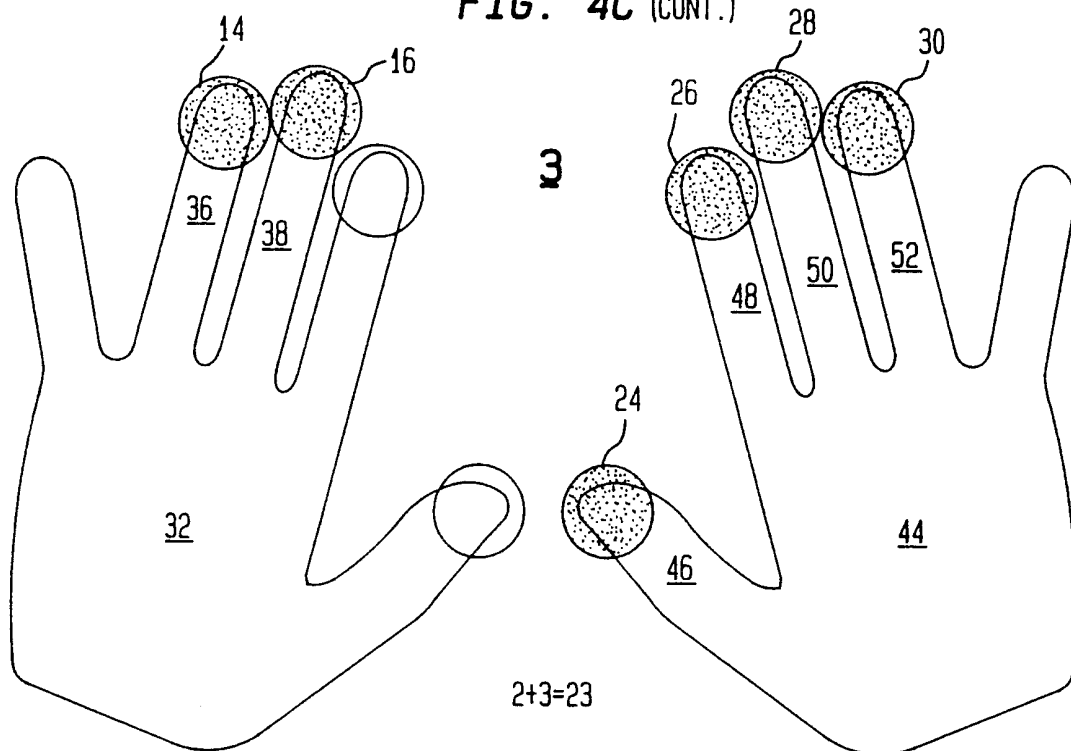
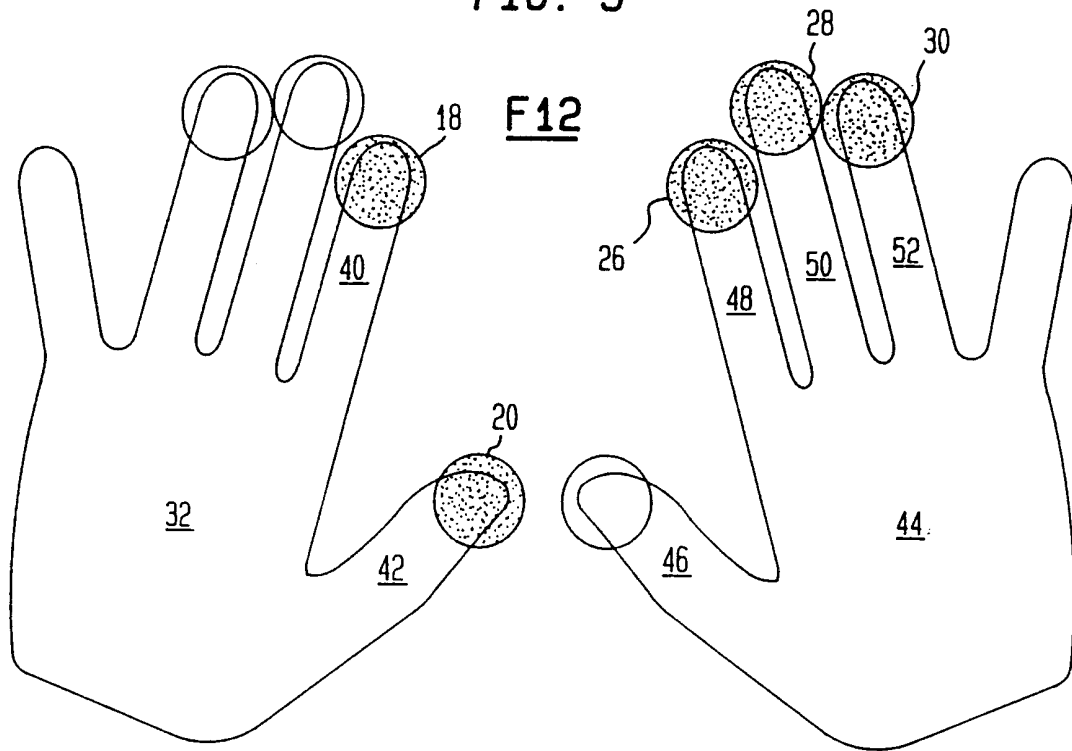


FIG. 4C (CONT.)



2+3=23

FIG. 5



23/37

FIG. 6

a e i o u y    A E I O U Y

a b c d    A B C D

e f g h    E F G H

i j k l m n    I J K L M N

o p q r s t    O P Q R S T

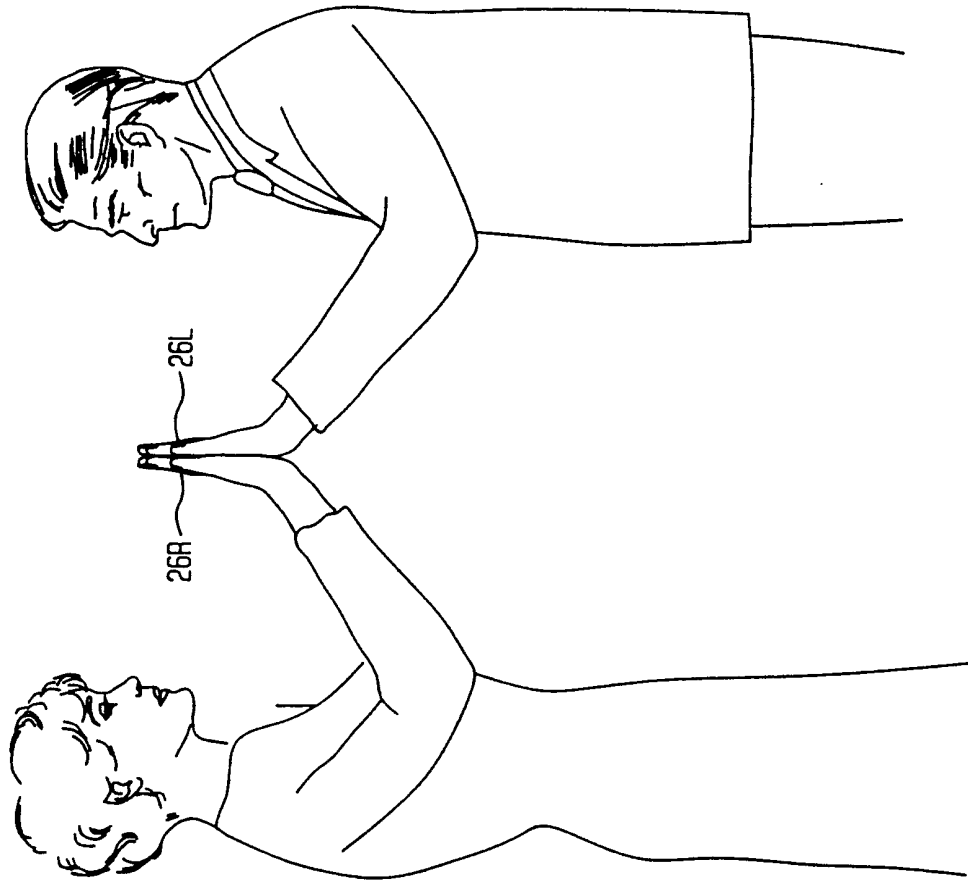
u v w x    U V W X

y z    Y Z    ( ) [ ] " " { } < >

. , ! ? ; : ' "

# 0 1 2 3 4 5 6 7 8 9 + \* - / =

**FIG. 7**  
(PRIOR ART)



25/37

**FIG. 8A**  
(PRIOR ART)

Sp	---	T	BkSp	RMI	Enter	---	IMR
a	---	T	A	---	Tab	---	MR
b	---	I	B	---	BkTb	RM	---
c	---	M	C	---	Ctrl	RMIT	I
d	---	R	D	---	Alt	RMIT	TR
e	---		E	---	ShftIn	RMIT	TI
f	---	I	F	---	ShftOut	RMIT	IR
g	---	M	G	---	Del	RMIT	---
h	---	R	H	---	Esc	RM	T
i	---		I	---	Insert	RMIT	TMR
j	---	IM	J	---	PgUp	MIT	T
k	---	MR	K	---	PgDn	MIT	R
l	---	I	L	---	.	---	I
m	---	M	M	---	,	---	R
n	---	R	N	---	!	---	M
o	R	---	O	R	---	?	TMR
p	R	IM	P	R	---	:	IM
q	R	MR	Q	R	---	;	IR
r	R	I	R	R	---	"	TI
s	R	M	S	R	---	'	TR
t	R	R	T	R	---	`	MR
u	MI	---	U	MI	---	(	MT
v	MI	I	V	MI	---	)	TM
w	MI	M	W	MI	---	[	RMT
x	MI	R	X	MI	---	]	TR
y	R	T	Y	R	T	{	RT
z	R	I	Z	R	T	}	TR
0	---	TMR				<	IR
1	R	TMR	F1	R	---	>	RI
2	M	TMR	F2	M	---		RMI
3	RM	TMR	F3	RM	---	\	RMI
4	I	TMR	F4	I	---		RMI
5	R	I	F5	R	I	/	RMI
6	MI	TMR	F6	MI	---	*	RM
7	RMI	TMR	F7	RMI	---	@	TR
8	T	TMR	F8	T	---	#	RM
9	R	T	F9	R	T	\$	RM
+	M	T	F10	M	T	^	IR
x	RM	T	F11	RM	T	&	RMI
-	IT	TMR	F12	IT	---		
/	R	IT	F13	R	IT		
=	MIT	TMR	F14	MIT	---		
			F15	RMIT	---		
Up	RMIT	T	Lt	RMIT	TI	Home	RMIT
Dn	RMIT	---	Rt	RMIT	---	End	RMIT

**FIG. 8B**

(PRIOR ART)

Sp	---	T		BkSp	---	---	IMR	Enter	RMI	---	---
a	---	T	---	A	---	T	---	Tab	RM	---	---
b	---	I	---	B	---	IT	---	BkTb	---	---	MR
c	---	M	---	C	---	M	T	Ctrl	---	---	TIMR
d	---	R	---	D	---	R	T	Alt	---	---	TIMR
e	---	I	---	E	---	T	---	ShftIn	---	---	TIMR
f	---	I	---	F	---	IT	---	ShftOut	---	---	TIMR
g	---	M	---	G	---	M	T	Del	---	---	TIMR
h	---	R	---	H	---	R	---	Esc	---	---	MR
i	---	---	M	I	---	T	---	Insert	---	---	TIMR
j	---	MI	---	J	---	MIT	---	PgUp	---	---	TIM
k	---	RM	---	K	---	RM	T	PgDn	---	---	TIM
l	---	I	---	L	---	IT	---	.	---	---	I
m	---	M	---	M	---	M	T	,	---	---	R
n	---	R	---	N	---	R	---	!	---	---	M
o	---	---	R	O	---	---	T	?	---	---	MIT
p	---	MI	---	P	---	MIT	---	:	---	---	MI
q	---	RM	---	Q	---	RM	T	;	---	---	R
r	---	I	---	R	---	IT	---	"	---	---	R
s	---	M	---	S	---	M	T	'	---	---	R
t	---	R	---	T	---	R	---	(	---	---	T
u	---	---	IM	U	---	---	T	)	---	---	M
v	---	I	---	V	---	IT	---	{	---	---	T
w	---	M	---	W	---	M	T	}	---	---	MR
x	---	R	---	X	---	R	---	[	---	---	R
y	---	---	T	Y	---	---	T	]	---	---	RM
z	---	I	---	Z	---	IT	---	{	---	---	T
0	---	RMIT	---					}	---	---	IT
1	---	RMIT	---	F1	---	RMI	---	<	---	---	R
2	---	RMIT	---	F2	---	RMI	---	>	---	---	I
3	---	RMIT	---	F3	---	RMI	---		---	---	I
4	---	RMIT	---	F4	---	RMI	---		---	---	R
5	---	RMIT	---	F5	---	RMI	---		---	---	IMR
6	---	RMIT	---	F6	---	RMI	---		---	---	IMR
7	---	RMIT	---	F7	---	RMI	---		---	---	IMR
8	---	RMIT	---	F8	---	RMI	---		---	---	IMR
9	---	RMIT	---	F9	---	RMI	---		---	---	MR
+	---	RMIT	---	F10	---	RMI	---		---	---	MR
x	---	RMIT	---	F11	---	RMI	---		---	---	MR
-	---	RMIT	---	F12	---	RMI	---		---	---	MR
/	---	RMIT	---	F13	---	RMI	---		---	---	MR
=	---	RMIT	---	F14	---	RMI	---		---	---	MR
				F15	---	RMI	---		---	---	MR
Up	---	T	---	Lt	---	IT	---	Home	---	---	TIMR
Dn	---	R	---	Rt	---	RM	---	End	---	---	TIMR



27/37

**FIG. 9**  
(PRIOR ART)

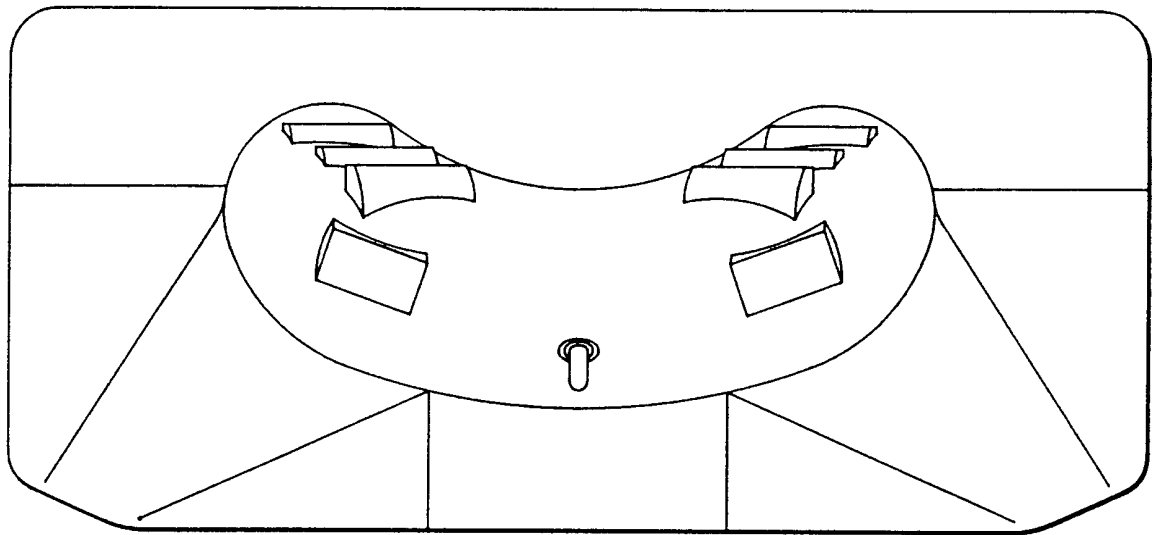
<i>Dec</i>	<i>Hex</i>	<i>Cbar</i>	<i>Dec</i>	<i>Hex</i>	<i>Cbar</i>	<i>Dec</i>	<i>Hex</i>	<i>Cbar</i>
0	00	NUL	44	2C	.	88	58	X
1	01	SOH	45	2D	-	89	59	Y
2	02	STX	46	2E	.	90	5A	Z
3	03	ETX	47	2F	/	91	5B	[
4	04	EOT	48	30	0	92	5C	\
5	05	ENQ	49	31	1	93	5D	]
6	06	ACK	50	32	2	94	5E	^
7	07	BEL	51	33	3	95	5F	~
8	08	BS	52	34	4	96	60	`
9	09	HT	53	35	5	97	61	a
10	0A	LF	54	36	6	98	62	b
11	0B	VT	55	37	7	99	63	c
12	0C	FF	56	38	8	100	64	d
13	0D	CR	57	39	9	101	65	e
14	0E	SO	58	3A	:	102	66	f
15	0F	SI	59	3B	;	103	67	g
16	10	DLE	60	3C	<	104	68	h
17	11	DC1	61	3D	=	105	69	i
18	12	DC2	62	3E	>	106	6A	j
19	13	DC3	63	3F	?	107	6B	k
20	14	DC4	64	40	@	108	6C	l
21	15	NAK	65	41	A	109	6D	m
22	16	SYN	66	42	B	110	6E	n
23	17	ETB	67	43	C	111	6F	o
24	18	CAN	68	44	D	112	70	p
25	19	EM	69	45	E	113	71	q
26	1A	SUB	70	46	F	114	72	r
27	1B	ESC	71	47	G	115	73	s
28	1C	FS	72	48	H	116	74	t
29	1D	GS	73	49	I	117	75	u
30	1E	RS	74	4A	J	118	76	v
31	1F	US	75	4B	K	119	77	w
32	20	<space>	76	4C	L	120	78	x
33	21	!	77	4D	M	121	79	y
34	22	"	78	4E	N	122	7A	z
35	23	#	79	4F	O	123	7B	{
36	24	\$	80	50	P	124	7C	
37	25	%	81	51	Q	125	7D	}
38	26	&	82	52	R	126	7E	~
39	27	'	83	53	S	127	7F	DEL
40	28	(	84	54	T			
41	29	)	85	55	U			
42	2A	*	86	56	V			
43	2B	+	87	57	W			

28/37

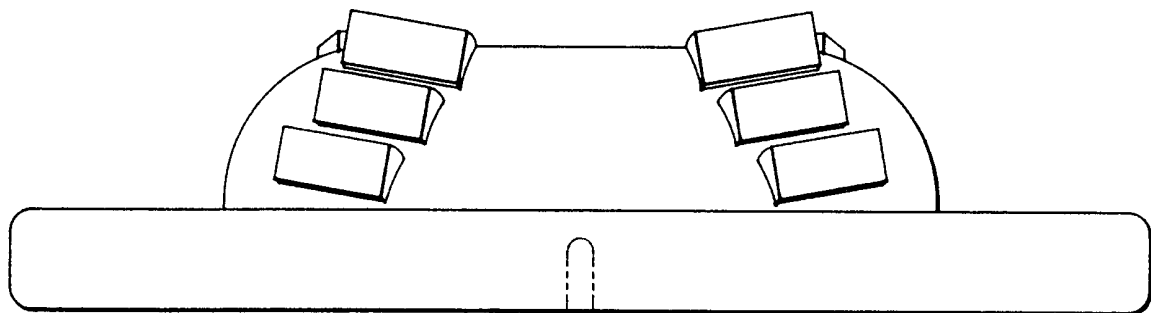
**FIG. 10**  
(PRIOR ART)

<i>Dec</i>	<i>Hex</i>	<i>Char</i>	<i>Dec</i>	<i>Hex</i>	<i>Char</i>	<i>Dec</i>	<i>Hex</i>	<i>Char</i>
128	80	Ç	171	AB	†	214	D6	¶
129	81	ù	172	AC	‡	215	D7	‡
130	82	é	173	AD	i	216	D8	+
131	83	à	174	AE	«	217	D9	∟
132	84	â	175	AF	»	218	DA	∟
133	85	à	176	B0	■	219	DB	■
134	86	á	177	B1	■	220	DC	■
135	87	ç	178	B2	■	221	DD	■
136	88	è	179	B3		222	DE	■
137	89	é	180	B4		223	DF	■
138	8A	è	181	B5		224	E0	α
139	8B	ï	182	B6		225	E1	β
140	8C	î	183	B7		226	E2	Γ
141	8D	ì	184	B8		227	E3	π
142	8E	Ä	185	B9		228	E4	Σ
143	8F	Á	186	BA		229	E5	σ
144	90	É	187	BB		230	E6	μ
145	91	æ	188	BC		231	E7	τ
146	92	Æ	189	BD		232	E8	φ
147	93	ò	190	BE		233	E9	θ
148	94	ó	191	BF		234	EA	Ω
149	95	ò	192	C0		235	EB	δ
150	96	ù	193	C1		236	EC	ε
151	97	ù	194	C2		237	ED	φ
152	98	ý	195	C3		238	EE	ε
153	99	Ö	196	C4		239	EF	∩
154	9A	Ü	197	C5		240	F0	■
155	9B	ø	198	C6		241	F1	±
156	9C	£	199	C7		242	F2	Σ
157	9D	¥	200	C8		243	F3	∞
158	9E	₽	201	C9		244	F4	∫
159	9F	f	202	CA		245	F5	∫
160	A0	á	203	CB		246	F6	+
161	A1	í	204	CC		247	F7	≈
162	A2	ó	205	CD		248	F8	°
163	A3	ú	206	CE		249	F9	°
164	A4	ñ	207	CF		250	FA	√
165	A5	Ñ	208	D0		251	FB	√
166	A6	•	209	D1		252	FC	•
167	A7	•	210	D2		253	FD	•
168	A8	∟	211	D3		254	FE	•
169	A9	∟	212	D4		255	FF	•
170	AA	∟	213	D5				

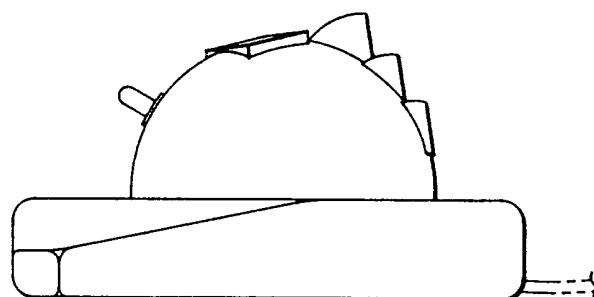
**FIG. 11**  
(PRIOR ART)



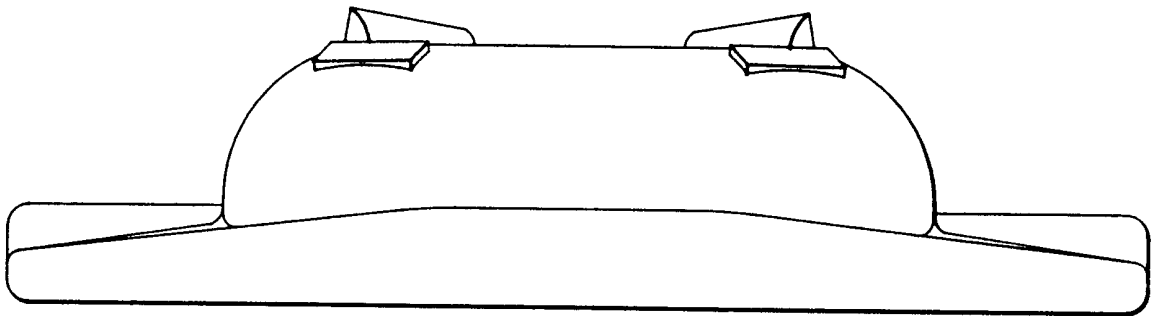
**FIG. 12**  
(PRIOR ART)



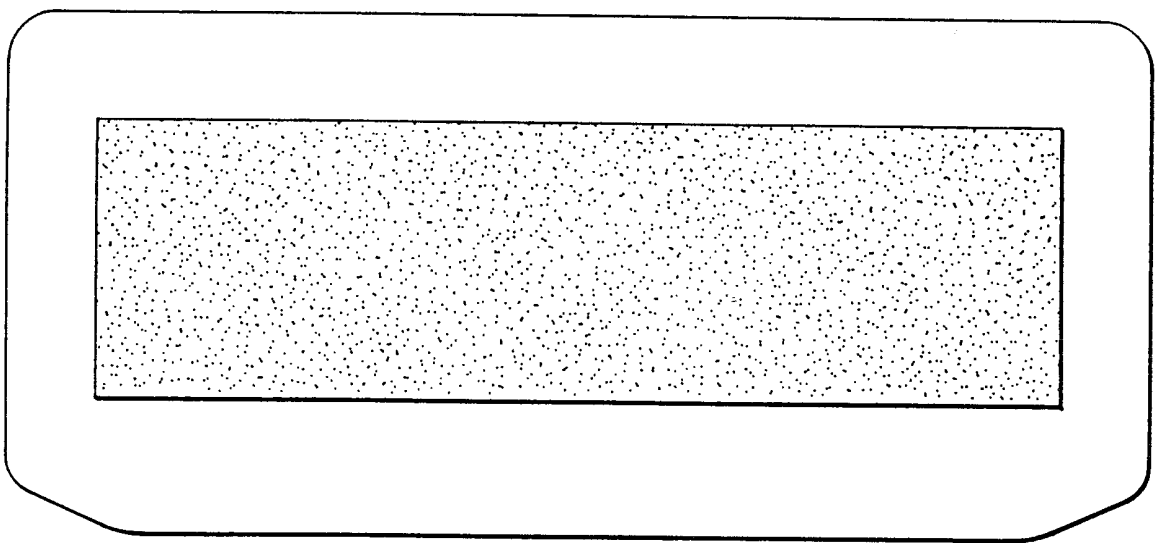
**FIG. 13**  
(PRIOR ART)



**FIG. 14**  
(PRIOR ART)

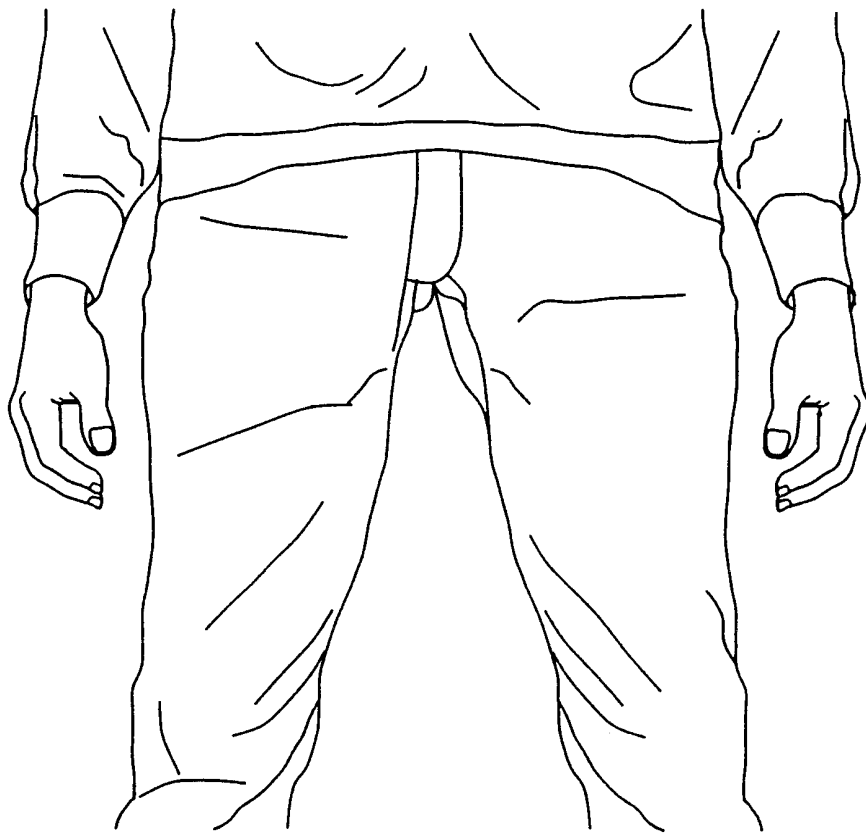


**FIG. 15**  
(PRIOR ART)



31/37

**FIG. 16**  
(PRIOR ART)



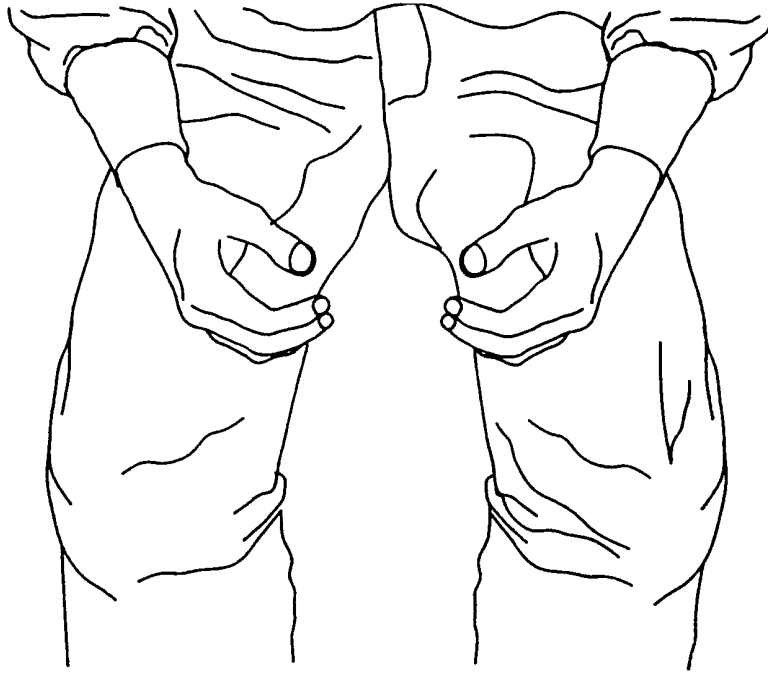
32/37

**FIG. 17**  
(PRIOR ART)

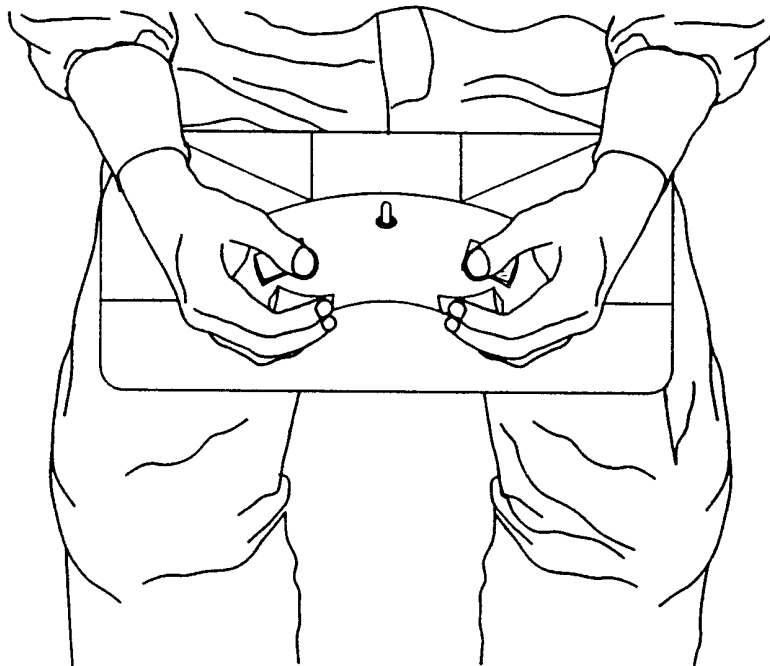


33/37

**FIG. 18**  
(PRIOR ART)



**FIG. 19**  
(PRIOR ART)



34/37

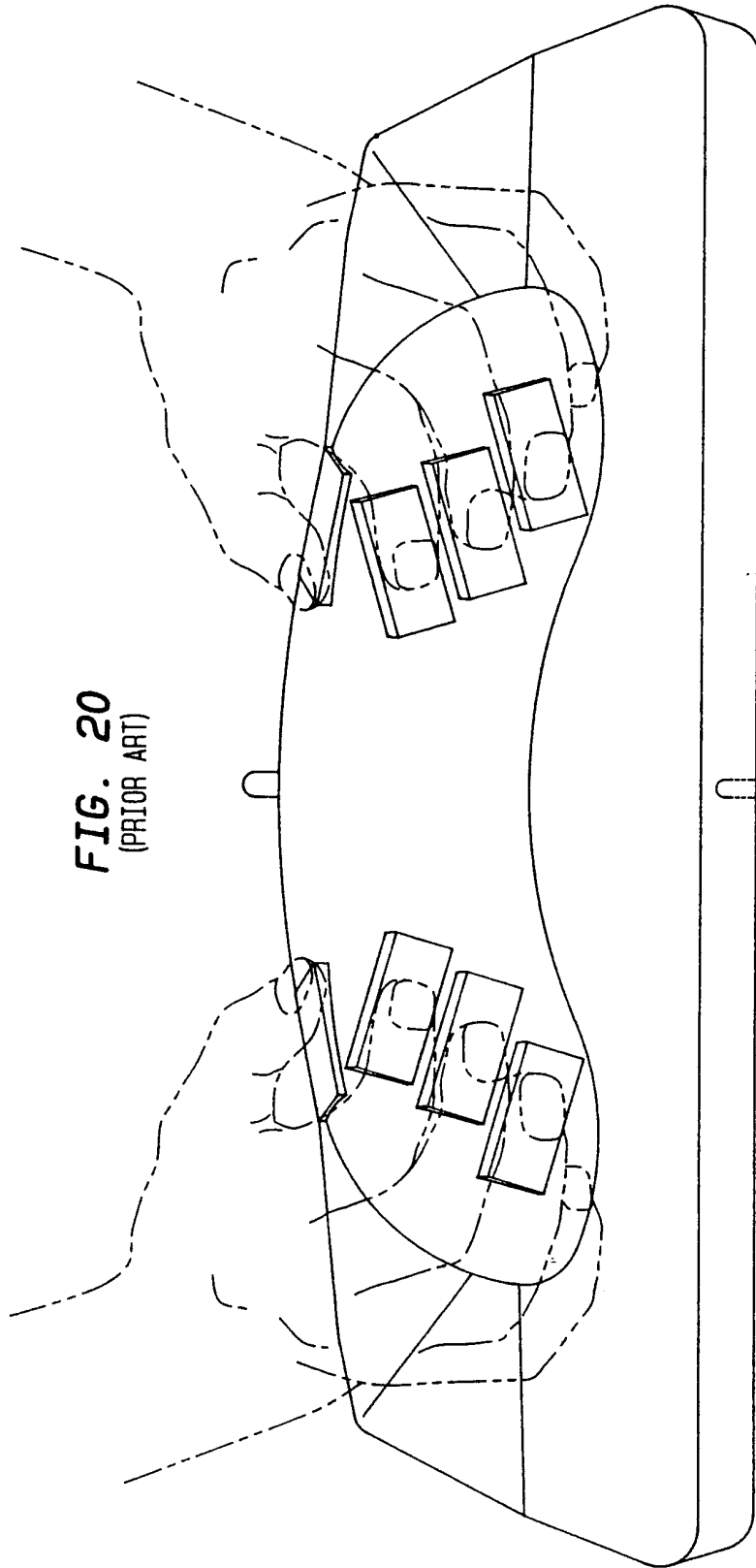
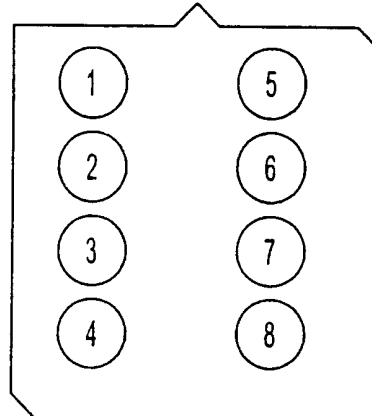


FIG. 20  
(PRIOR ART)

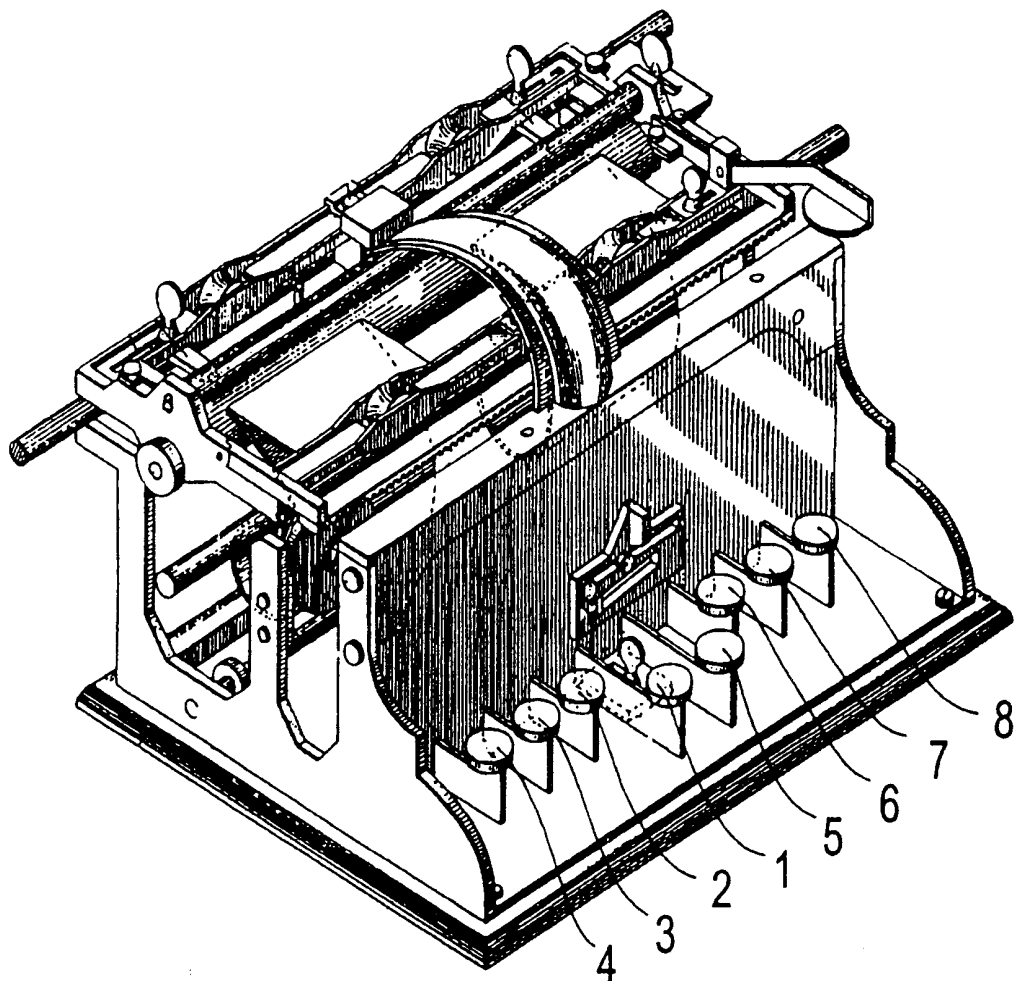


35/37

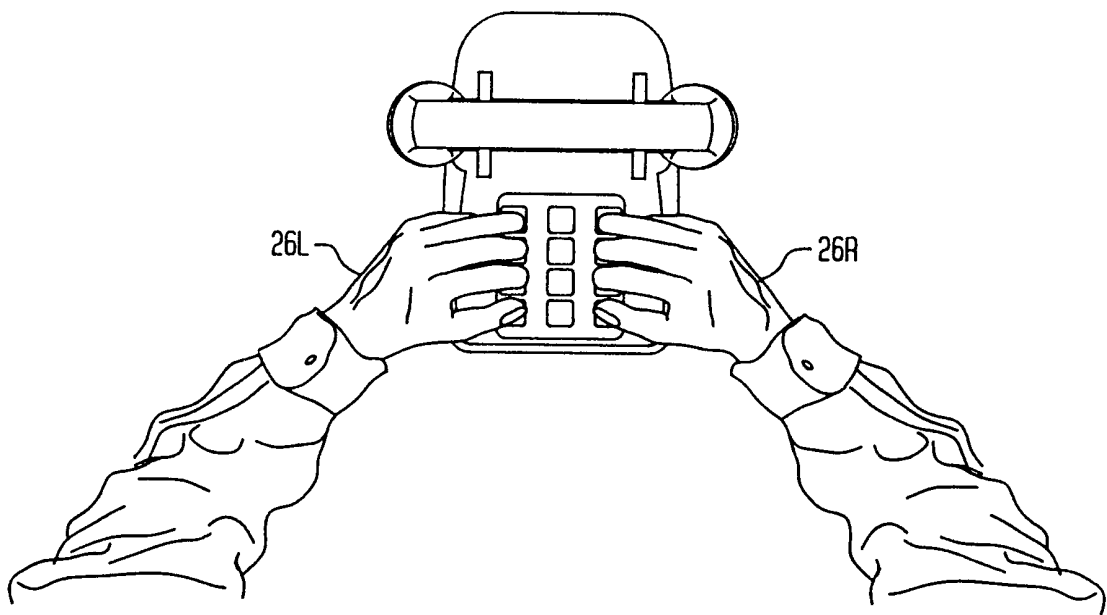
**FIG. 21A**  
(PRIOR ART)



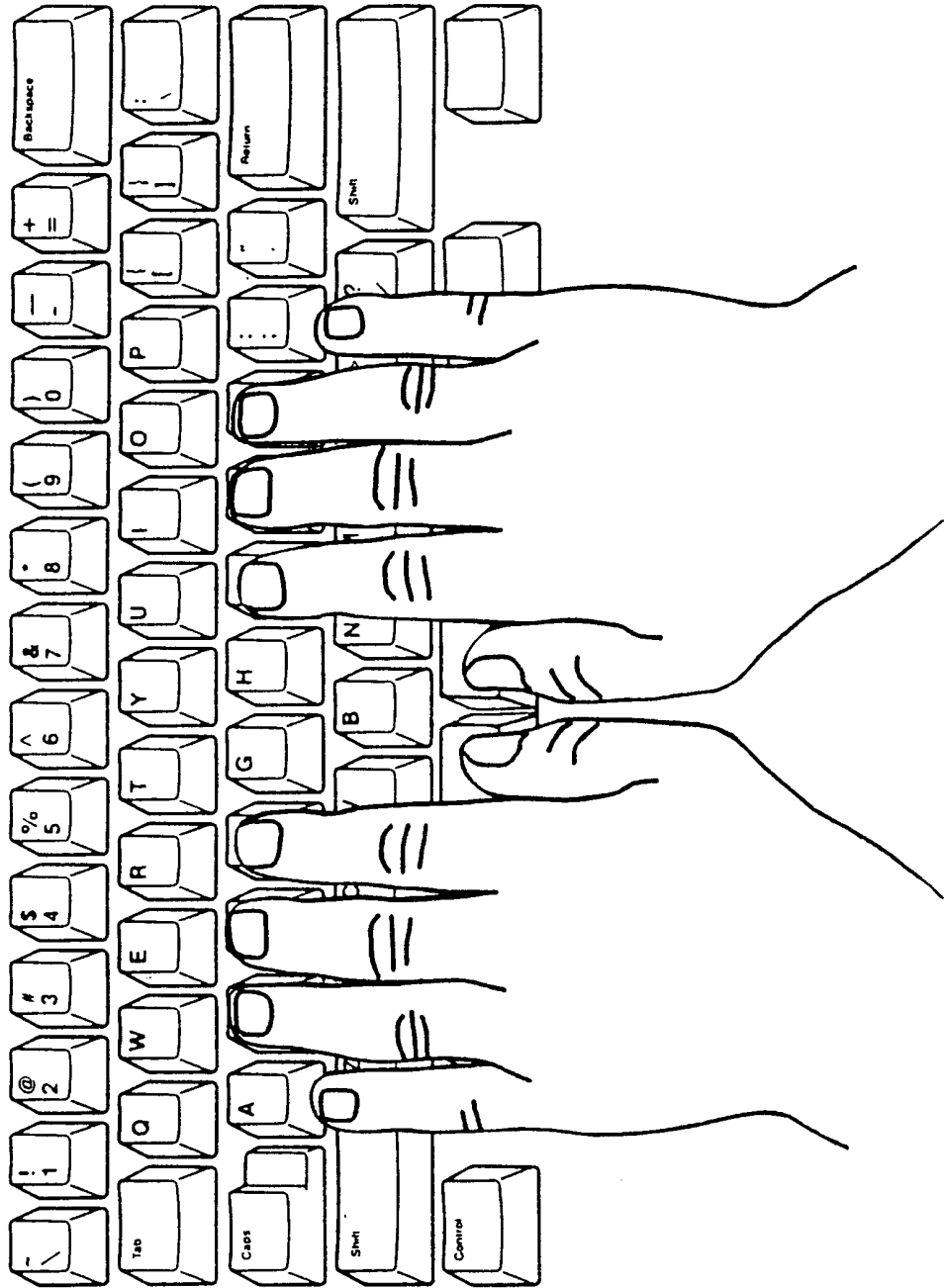
**FIG. 21B**  
(PRIOR ART)



**FIG. 22**  
(PRIOR ART)



**FIG. 23**  
(PRIOR ART)



INTERNATIONAL SEARCH REPORT

International application No.  
PCT/US99/27998

**A. CLASSIFICATION OF SUBJECT MATTER**  
 IPC ( ) : H03K 17/94; B41J 5/06, 5/08  
 US CL : 341/20, 21, 22; 400/100, 485  
 According to International Patent Classification (IPC) or to both national classification and IPC

**B. FIELDS SEARCHED**  
 Minimum documentation searched (classification system followed by classification symbols)  
 U.S. : 341/20, 21, 22; 400/100, 485

Documentation searched other than minimum documentation to the extent that such documents are included in the fields searched  
 NONE

Electronic data base consulted during the international search (name of data base and, where practicable, search terms used)  
 EAST  
 CHORDIC KEYBOARD, BRAILLE

**C. DOCUMENTS CONSIDERED TO BE RELEVANT**

Category*	Citation of document, with indication, where appropriate, of the relevant passages	Relevant to claim N
X	US 4,655,621 A (HOLDEN) 07 April 1987, see entire patent.	1-4,11-14, 21,22
Y		5-10, 15-20
Y	BACON, R.E. Easy-to-Learn Programable Keyboard IBM tech.dis. bull. OCTOBER, 1981. Vol 24. No. 5. page 2465	5-10, 15-20

Further documents are listed in the continuation of Box C.  See patent family annex.

* Special categories of cited documents:	*T* later document published after the international filing date or priority date and not in conflict with the application but cited to understand the principle or theory underlying the invention
*A* document defining the general state of the art which is not considered to be of particular relevance	*X* document of particular relevance; the claimed invention cannot be considered novel or cannot be considered to involve an inventive step when the document is taken alone
*E* earlier document published on or after the international filing date	*Y* document of particular relevance; the claimed invention cannot be considered to involve an inventive step when the document is considered with one or more other such documents, such combination being obvious to a person skilled in the art
*L* document which may throw doubts on priority claim(s) or which is cited to establish the publication date of another citation or other special reason (as specified)	*&* document member of the same patent family
*O* document referring to an oral disclosure, use, exhibition or other means	
*P* document published prior to the international filing date but later than the priority date claimed	

Date of the actual completion of the international search 28 MARCH 2000	Date of mailing of the international search report <b>26 APR 2000</b>
--	--

Name and mailing address of the ISA/US Commissioner of Patents and Trademarks Box PCT Washington, D.C. 20231 Facsimile No. (703)305-3230	Authorized officer Timothy Edwards <i>For Bulgaria Zogler</i> Telephone No. (703) 305-4896
--	--