



- (51) International Patent Classification:
A61B 1/05 (2006.01) A61B 1/06 (2006.01)
A61B 1/005 (2006.01)
- (21) International Application Number:
PCT/IL2013/050840
- (22) International Filing Date:
17 October 2013 (17.10.2013)
- (25) Filing Language: English
- (26) Publication Language: English
- (30) Priority Data:
13/655,120 18 October 2012 (18.10.2012) US
- (71) Applicant: ENDOCHOICE INNOVATION CENTER LTD. [IL/IL]; 2 Hatochen Street, North Industrial Park, 30889 Caesarea (IL).
- (72) Inventor: LEVY, Avi; 37 Asher Barash Street, 3088900 Herzliya (IL).

- (74) Agents: WEBB & CO. et al.; P.O. Box 2189, 76121 Rehovot (IL).
- (81) Designated States (unless otherwise indicated, for every kind of national protection available): AE, AG, AL, AM, AO, AT, AU, AZ, BA, BB, BG, BH, BN, BR, BW, BY, BZ, CA, CH, CL, CN, CO, CR, CU, CZ, DE, DK, DM, DO, DZ, EC, EE, EG, ES, FI, GB, GD, GE, GH, GM, GT, HN, HR, HU, ID, IL, IN, IR, IS, JP, KE, KG, KN, KP, KR, KZ, LA, LC, LK, LR, LS, LT, LU, LY, MA, MD, ME, MG, MK, MN, MW, MX, MY, MZ, NA, NG, NI, NO, NZ, OM, PA, PE, PG, PH, PL, PT, QA, RO, RS, RU, RW, SA, SC, SD, SE, SG, SK, SL, SM, ST, SV, SY, TH, TJ, TM, TN, TR, TT, TZ, UA, UG, US, UZ, VC, VN, ZA, ZM, ZW.
- (84) Designated States (unless otherwise indicated, for every kind of regional protection available): ARIPO (BW, GH, GM, KE, LR, LS, MW, MZ, NA, RW, SD, SL, SZ, TZ, UG, ZM, ZW), Eurasian (AM, AZ, BY, KG, KZ, RU, TJ, TM), European (AL, AT, BE, BG, CH, CY, CZ, DE, DK,

[Continued on next page]

(54) Title: MULTI-CAMERA ENDOSCOPE

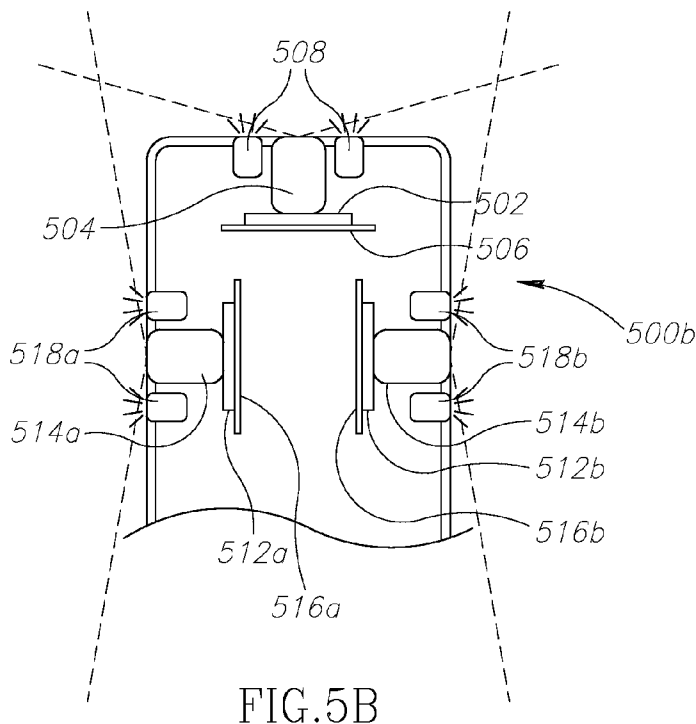

FIG. 5B

[Continued on next page]





EE, ES, FI, FR, GB, GR, HR, HU, IE, IS, IT, LT, LU, **Published:**

LV, MC, MK, MT, NL, NO, PL, PT, RO, RS, SE, SI, SK,

SM, TR), OAPI (BF, BJ, CF, CG, CI, CM, GA, GN, GQ,

GW, KM, ML, MR, NE, SN, TD, TG).

— with international search report (Art. 21(3))

Declarations under Rule 4.17:

— of inventorship (Rule 4.17(iv))

(57) Abstract: There is provided herein a tip section of a multi-camera endoscope, the tip section comprising a front-pointing camera and a discrete front illuminator associated therewith two or more side-pointing cameras positioned at or in proximity to a distal end of said tip section, wherein each of said two or more side-pointing cameras having a discrete side illuminator associated therewith, and a working channel configured for insertion of a surgical tool.

MULTI-CAMERA ENDOSCOPE**FIELD**

Embodiments of the disclosure relate to a multi-camera endoscope.

BACKGROUND

5 Endoscopes have attained great acceptance within the medical community, since they provide a means for performing procedures with minimal patient trauma, while enabling the physician to view the internal anatomy of the patient. Over the years, numerous endoscopes have been developed and categorized according to specific applications, such as cystoscopy, colonoscopy, laparoscopy, upper GI endoscopy and others. Endoscopes may be inserted into
10 the body's natural orifices or through an incision in the skin.

An endoscope is usually an elongated tubular shaft, rigid or flexible, having a video camera or a fiber optic lens assembly at its distal end. The shaft is connected to a handle, which sometimes includes an ocular for direct viewing. Viewing is also usually possible via an external screen. Various surgical tools may be inserted through a working channel in the
15 endoscope for performing different surgical procedures.

The foregoing examples of the related art and limitations related therewith are intended to be illustrative and not exclusive. Other limitations of the related art will become apparent to those of skill in the art upon a reading of the specification and a study of the figures.

SUMMARY

20 The following embodiments and aspects thereof are described and illustrated in conjunction with systems, tools and methods which are meant to be exemplary and illustrative, not limiting in scope.

There is provided, according to some embodiments, a tip section of a multi-camera endoscope, the tip section comprising a front-pointing camera and a discrete front illuminator
25 associated therewith, two or more side-pointing cameras positioned at or in proximity to a distal end of the tip section, wherein each of the two or more side-pointing cameras having a

discrete side illuminator associated therewith; and a working channel configured for insertion of a surgical tool.

There is further provided, according to some embodiments, a multi-camera endoscope comprising an elongated shaft terminating with a tip section turnable by way of a bending section, wherein the tip section comprises a front-pointing camera and a discrete front illuminator associated therewith, two or more side-pointing cameras positioned at or in proximity to a distal end of the tip section, wherein each of the two or more side-pointing cameras having a discrete side illuminator associated therewith, and a working channel configured for insertion of a surgical tool.

The tip section may further include a pathway fluid injector for inflating and/or cleaning a body cavity into which the endoscope is inserted.

The tip section may further include a fluid injector configured for cleaning the front-pointing camera and/or the discrete front illuminator. The tip section may further include two or more side fluid injectors configured for cleaning the two or more side-pointing cameras and/or the discrete side illuminators.

The tip section may include two side-pointing cameras. The tip section may further include two side-pointing cameras pointing at directions essentially opposing to one another.

The tip section may further include three or more (for example, three, four, five, six or more) side-pointing cameras positioned essentially at equal distances from each other along the perimeter of the tip section.

According to some embodiments, the discrete front illuminator may include a light-emitting diode (LED). According to some embodiments, each of the discrete side illuminators may include a light-emitting diode (LED). According to some embodiments, each of the discrete front and side illuminators may include a light-emitting diode (LED).

25

There is provided, according to some embodiments, a tip section of a multi-camera endoscope, the tip section comprising: two or more side-pointing cameras positioned at or in proximity to a distal end of the tip section, wherein the field of view provided by the two or

more side-pointing cameras covers a front and side views; one or more discrete illuminator; a working channel configured for insertion of a surgical tool; and a pathway fluid injector for inflating and/or cleaning a body cavity into which the endoscope is inserted.

5 There is provided, according to some embodiments, a tip section of a multi-camera endoscope, the tip section comprising: three side-pointing cameras positioned at or in proximity to a distal end of the tip section, wherein the field of view provided by the three side-pointing cameras covers a front and side views; one or more discrete illuminator; a working channel configured for insertion of a surgical tool; and a pathway fluid injector for inflating and/or cleaning a body cavity into which the endoscope is inserted.

10 There is provided, according to some embodiments, a tip section of a multi-camera endoscope, the tip section comprising: three side-pointing cameras positioned at or in proximity to a distal end of the tip section, wherein the field of view provided by the three side-pointing cameras covers a front and side views; three discrete illuminators (such as LEDs), each associated with each one of the three side-pointing cameras; and a working
15 channel configured for insertion of a surgical tool.

There is provided, according to some embodiments, a tip section of a multi-camera endoscope, the tip section comprising: three side-pointing cameras positioned at or in proximity to a distal end of the tip section, wherein the field of view provided by the three side-pointing cameras covers a front and side views; one front discrete illuminator (such as a
20 LED), and a working channel configured for insertion of a surgical tool.

The tip section may further include a pathway fluid injector for inflating and/or cleaning a body cavity into which the endoscope is inserted.

25 There is provided, according to some embodiments, a multi-camera endoscope comprising: an elongated shaft terminating with a tip section turnable by way of a bending section, wherein the tip section comprises: two or more side-pointing cameras positioned at or in proximity to a distal end of the tip section, wherein the field of view provided by the two or more side-pointing cameras covers a front and side views; one or more discrete illuminator; a working channel configured for insertion of a surgical tool; and a pathway fluid injector for inflating and/or cleaning a body cavity into which the endoscope is inserted.

There is provided, according to some embodiments, a multi-camera endoscope comprising: an elongated shaft terminating with a tip section turnable by way of a bending section, wherein the tip section comprises: three side-pointing cameras positioned at or in proximity to a distal end of the tip section, wherein the field of view provided by the three side-pointing cameras covers a front and side views; three discrete illuminators (such as LEDs), each associated with each one of the three side-pointing cameras, and a working channel configured for insertion of a surgical tool.

There is provided, according to some embodiments, a multi-camera endoscope comprising: an elongated shaft terminating with a tip section turnable by way of a bending section, wherein the tip section comprises: three side-pointing cameras positioned at or in proximity to a distal end of the tip section, wherein the field of view provided by the three side-pointing cameras covers a front and side views; one front discrete illuminator (such as a LED), and a working channel configured for insertion of a surgical tool.

The multi-camera endoscope may further include a pathway fluid injector for inflating and/or cleaning a body cavity into which the endoscope is inserted.

There is provided, according to some embodiments, a tip section of a multi-camera endoscope, the tip section comprising: two or more side-pointing cameras positioned at or in proximity to a distal end of the tip section, wherein each of the two or more side-pointing cameras having a discrete illuminator associated therewith, wherein the field of view provided by the two or more side-pointing cameras covers a front and side views; a working channel configured for insertion of a surgical tool; and a pathway fluid injector for inflating and/or cleaning a body cavity into which the endoscope is inserted.

There is provided, according to some embodiments, a multi-camera endoscope comprising: an elongated shaft terminating with a tip section turnable by way of a bending section, wherein the tip section comprises: two or more side-pointing cameras positioned at or in proximity to a distal end of the tip section, wherein each of the two or more side-pointing cameras having a discrete illuminator associated therewith, wherein the field of view provided by the two or more side-pointing cameras covers a front and side views; a working channel configured for insertion of a surgical tool; and a pathway fluid injector for inflating and/or cleaning a body cavity into which the endoscope is inserted.

The tip section may further include two or more side fluid injectors configured for cleaning the two or more side-pointing cameras and/or the discrete side illuminators. The two or more side-pointing cameras may point at directions essentially opposing to one another. The tip section may include three or more side-pointing cameras. According to some
5 embodiments, the three or more side-pointing cameras may be positioned essentially at equal distances from each other along the perimeter of the tip section.

There is provided, according to some embodiments, a tip section of a multi-camera endoscope, the tip section comprising: a front-pointing camera and a discrete front illuminator associated therewith; a front fluid injector configured for cleaning at least one of
10 the front-pointing camera and the discrete front illuminator; a side-pointing camera; a working channel configured for insertion of a surgical tool; and a pathway fluid injector for inflating and/or cleaning a body cavity into which the endoscope is inserted.

There is provided, according to some embodiments, a multi-camera endoscope comprising: an elongated shaft terminating with a tip section turnable by way of a bending
15 section, wherein the tip section comprises: two or more side-pointing cameras positioned at or in proximity to a distal end of the tip section, wherein each of the two or more side-pointing cameras having a discrete illuminator associated therewith, wherein the field of view provided by the two or more side-pointing cameras covers a front and side views; a working
20 channel configured for insertion of a surgical tool; and a pathway fluid injector for inflating and/or cleaning a body cavity into which the endoscope is inserted. The tip section may further include a discrete side illuminator associated with side-pointing camera. The tip section may further include a side fluid injector configured for cleaning the side-pointing camera and/or the discrete side illuminator.

There is provided, according to an embodiment, a multi-camera endoscope comprising:
25 an elongated shaft terminating with a tip section turnable by way of a bending section, wherein the tip section comprises: a front-pointing camera and a discrete front illuminator associated therewith; a front fluid injector configured for cleaning at least one of the front-pointing camera and the discrete front illuminator; a side-pointing camera and a discrete side
30 illuminator associated therewith; a side fluid injector configured for cleaning at least one of the side-pointing camera and the discrete side illuminator; a working channel configured for

insertion of a surgical tool; and a pathway fluid injector for inflating and/or cleaning a body cavity into which the endoscope is inserted.

There is further provided, according to an embodiment, a multi-camera endoscopy system comprising: an endoscope comprising a handle and an elongated shaft terminating with a tip section turnable by way of a bending section, wherein the tip section comprises: a front-pointing camera and a discrete front illuminator associated therewith, a front fluid injector configured for cleaning at least one of the front-pointing camera and the discrete front illuminator, a side-pointing camera and a discrete side illuminator associated therewith, a side fluid injector configured for cleaning at least one of the side-pointing camera and the discrete side illuminator, a working channel configured for insertion of a surgical tool, and a pathway fluid injector for inflating and/or cleaning a body cavity into which the endoscope is inserted; a controller connected to the handle of the endoscope by way of a utility cable; and a display connected to the controller and configured to display video streams received from the front and side-pointing cameras.

In some embodiments, the front-pointing camera and the side-pointing camera are pointing at directions essentially perpendicular to one another.

In some embodiments, the front-pointing camera and the side-pointing camera are pointing approximately 100 to 145 degrees relative to one another.

In some embodiments, a center of the side-pointing camera is positioned approximately 7 to 11 millimeters from a distal end of the tip section.

In some embodiments, each of the discrete front and side illuminators comprises a light-emitting diode (LED).

In some embodiments, at least one of the discrete front and side illuminators is configured to emit white light.

In some embodiments, at least one of the discrete front and side illuminators is configured to emit ultraviolet light.

In some embodiments, at least one of the discrete front and side illuminators is configured to emit infrared light.

In some embodiments, at least one of the discrete front and side illuminators is configured to emit near-infrared light.

In some embodiments, the discrete front and side illuminators are configured to emit light in different wavelengths.

- 5 In some embodiments, the tip section further comprises an additional discrete front illuminator configured to emit light having a different wavelength than the discrete front illuminator.

In some embodiments, the additional discrete front illuminator and the discrete front illuminator are configured to simultaneously emit light, each at a different wavelength.

- 10 In some embodiments, the tip section further comprises an additional discrete side illuminator configured to emit light having a different wavelength than the discrete side illuminator.

In some embodiments, the additional discrete side illuminator and the discrete side illuminator are configured to simultaneously emit light, each at a different wavelength.

- 15 In some embodiments, each of the front-pointing camera and the side-pointing camera comprises a Charge Coupled Device (CCD) or a Complementary Metal Oxide Semiconductor (CMOS) image sensor.

In some embodiments, the front and side fluid injectors are connected to a same fluid supply channel.

- 20 In some embodiments, the pathway fluid injector is connected to the fluid supply channel, together with the front and side fluid injectors.

In some embodiments, at least one of the front and side-pointing cameras comprises a lens assembly providing a field of view of 90 degrees or more.

- 25 In some embodiments, at least one of the front and side-pointing cameras comprises a lens assembly providing a field of view of 120 degrees or more.

In some embodiments, at least one of the front and side-pointing cameras comprises a lens assembly providing a field of view of 150 degrees or more.

In some embodiments, the front-pointing camera comprises a lens assembly providing a focal length of approximately 3-100 millimeters.

5 In some embodiments, the side-pointing camera comprises a lens assembly providing a focal length of approximately 2-33 millimeters.

In some embodiments, the tip section further comprises an opposite side-pointing camera pointing at a direction essentially opposite to the side-pointing camera.

10 In some embodiments, the tip section further comprises a perpendicular side-pointing camera pointing at a direction essentially perpendicular to the side-pointing camera.

In some embodiments, the endoscope is a colonoscope.

15 In some embodiments, fields of view of the front-pointing camera and side-pointing camera are at least partially overlapping, such that an object of interest viewed via the side-pointing camera remains in the field of view of the side-pointing camera while the tip section is being turned towards the object, and at least until the object becomes visible through the front-pointing camera.

20 In some embodiments, the utility cable comprises: a fluid channel for providing a fluid to at least one of the injectors; a data cable for receiving video signals from the front and side-pointing cameras; and a power cable for providing electrical power to the front and side-pointing cameras and to the discrete front and side illuminators.

In some embodiments, the controller is configured to process and combine video signals received from the front and side-pointing cameras into a single panoramic video view.

25 In addition to the exemplary aspects and embodiments described above, further aspects and embodiments will become apparent by reference to the figures and by study of the following detailed description.

BRIEF DESCRIPTION OF THE FIGURES

Exemplary embodiments are illustrated in referenced figures. Dimensions of components and features shown in the figures are generally chosen for convenience and clarity of presentation and are not necessarily shown to scale. It is intended that the
5 embodiments and figures disclosed herein are to be considered illustrative rather than restrictive. The figures are listed below:

Fig. 1 shows a cross sectional view of a prior art endoscope;

Fig. 2 shows a cross section of a multi-camera endoscope, according to some
embodiments;

10 Fig. 3 shows a perspective view of a multi-camera endoscope, according to some
embodiments;

Fig. 4 shows a cross-sectional view of a bending section of a multi-camera endoscope,
according to some embodiments;

15 Figs. 5 A-B show a cross-sectional views of tip sections of multi-camera endoscopes,
according to some embodiments;

Fig. 6 shows a semi-pictorial view of a multi-camera endoscopy system, according to
some embodiments;

Figs. 7A-D show perspective views of multiple tip section configurations, according to
some embodiments;

20 Fig. 8 shows a perspective view of a multi-camera endoscope, according to some
embodiments; and

Fig. 9 shows a perspective view of a multi-camera endoscope, according to some
embodiments.

DETAILED DESCRIPTION

25 An aspect of some embodiments relates to an endoscope having a tip section equipped
with two or more cameras. According to one embodiment, one of the cameras is positioned at

a distal end of the tip section and points forward, and the remaining camera(s) is positioned further back in the tip section, and points sideways.

According to another embodiment, one of the cameras is positioned at a distal (front) end surface of the tip section and points forward, and the remaining camera(s) is positioned
5 further back in the tip section, and points sideways.

According to another embodiment, two or more cameras (for example, three, four or more) are positioned in proximity to or at the distal end of the tip section and point sideways such that the field of view provided by the cameras covers a front and side views. Even though in such configuration, according to some embodiments, no camera is positioned at the
10 distal (front) end surface of the tip section (or in other words, no camera is pointing directly forward), still the field of view of the side cameras allows view of the front direction of the tip and accordingly of the endoscope.

This configuration, advantageously, may allow for a higher rate of detection, compared to conventional configurations, of pathological objects that exist in the body cavity in which
15 the endoscope operates.

The cameras and optionally other elements that exist in the tip section (such as a light source, a working channel, a fluid injector and/or the like) are uniquely scaled, configured and packaged so that they fit within the minimalistic space available inside the tip section, while still providing valuable results.

Reference is now made to Fig. 1, which shows a cross sectional view of a prior art
20 endoscope, in this example a colonoscope 100, used within a colon 120 of a patient. The human colon includes a series of annular muscles which appear in this figure as folds 122 protruding from an inner surface 124 of the colon.

Endoscope 100 includes a front-pointing camera 104 positioned at a distal end 102 of
25 the colonoscope. Camera 104 typically has a wide field of view 106. When endoscope 100 is used within a body cavity such as colon 120, the operator advances the endoscope 100 while viewing images (commonly a video feed) transmitted by camera 104. When a polyp, such as polyp 110 or 112 is discovered on a wall of colon 120, the operator may insert a surgical tool

(not shown) through a working channel 105 to remove, treat and/or extract a sample of the polyp or its entirety for biopsy.

However, in some cases, a polyp, such as polyp 114 may be located on an inner side of a fold 126, such that it is hidden from the field of view 106 of camera 104. This phenomena
5 greatly contributes to the common statistics, according to which as many as 12-24% of polyps are missed during colonoscopy. Missing polyps, or a “false negative” diagnosis, may result in late discovery of cancer.

Reference is now made to Fig. 2, which shows a cross section of a multi-camera
10 endoscope 200, according to an embodiment. Endoscope 200 may include an elongated shaft 203 (not fully shown) terminating with a tip section 202 which is turnable by way of a bending section 204. Advantageously, tip section may include a front-pointing camera 206 as well as a side-pointing camera 210. While front-pointing camera 206 may be able to detect, based on its field of view 208, polyps such as polyps 218 and 220, side-pointing camera 210 may be further able to detect polyps which are normally hidden from the front-pointing
15 camera, such as polyp 216. By rotating endoscope 200 around its longitude, side-pointing camera 210 may detect polyps circumferentially, 360 degrees around the endoscope. This may enable the detection of polyps such as a polyp 222, which is, similar to polyp 216, located on an inner side of a fold. In other configurations (not shown), two or more side-pointing cameras may exist in the tip section, each having a different (or an overlapping, to
20 some degree) field of view.

Advantageously, the fields of view of front-pointing camera 206 and side-pointing camera 210 are at least partially overlapping, such that an object of interest (such as a polyp or another pathology) viewed via the side-pointing camera remains in the field of view of this camera while the tip section is being turned towards the object, and at least until the object
25 becomes visible through the front-pointing camera. This may be beneficial when a polyp is discovered by side-pointing camera 210, and the operator desires to perform a surgical operation on that polyp using a surgical tool inserted through a working channel (not shown in the figure) which has an opening in a distal end surface of tip section 202, next to front-pointing camera 206. For performing the surgical operation, tip section 202 may need to be
30 turned towards the polyp. It may greatly assist the operator if the fields of view of front-pointing camera 206 and side-pointing camera 210 have some overlap, so that the polyp

remains in sight throughout the turning of the tip section and the operator does not get disoriented.

Reference is now made to Fig. 3, which shows a perspective view of a multi-camera endoscope 300 in more detail, according to an embodiment. Endoscope 300 may include an elongated shaft (not shown), a bending section (partially shown) 302 and a tip section 304 which terminates the endoscope.

Bending section 302 may include a plurality of links, such as links 302a-c, which enable the turning of tip section 304 in different directions. In a different configuration (not shown), a bending section may be constructed differently, as long as it enables the turning of the tip section in different directions. Bending section 302 may be covered with an elastic sheath (not shown), which may also extend to cover the elongated shaft.

Tip section 304 may include therein a front-pointing camera 304 which may capture images through a hole in a distal end surface 306 of the tip section. A discrete front illuminator 308, which is optionally a light-emitting diode (LED), may be associated with front-pointing camera 304 and used for illuminating its field of view through another hole in distal end surface 306. The LED may be a white light LED, an infrared light LED, a near infrared light LED or an ultraviolet light LED. The term “discrete”, in regard to front illuminator 308, may refer to an illumination source which generates light internally – in contrast to a non-discrete illuminator which may be, for example, a fiber optic merely transmitting light generated remotely. In a different configuration (not shown), two or more discrete front illuminators may be present in the tip section, such as for supplying overall stronger illumination and/or for increasing the angular coverage of the illumination. These two or more discrete front illuminators may be located next to one another so that they share a same protective window on the distal end surface of the tip section.

A front fluid injector 310 may be used for cleaning at least one of front-pointing camera 304 and discrete front illuminator 308. Front fluid injector 310 may be slightly elevated from distal end surface 306, to enable it to inject fluid, from its side 310a, onto front-pointing camera 304 and discrete front illuminator 308. Front fluid injector 310 may be configured to inject fluids such as water, air and/or the like.

Distal end surface 306 may further include a hole defining a working channel 312. Working channel 312 may be a hollow tube configured for insertion of a surgical tool to operate on various tissues. For example, miniature forceps may be inserted through working channel 312 in order to remove a polyp or sample of which for biopsy.

5 A pathway fluid injector 314, defined by another hole in distal end surface 306, may be used for inflating and/or cleaning the body cavity into which endoscope 300 is inserted. Inflation may be performed by flowing air or another gas through pathway fluid injector 314, and may be beneficial for cases in which the body cavity, such as the colon, is shriveled or otherwise does not allow for efficient inspection. Cleaning may be achieved, for example, by
10 injecting a liquid, such as water or saline, on an unclean area of the body cavity. Furthermore, pathway fluid injector 314 (or a different tube, not shown) may be used for applying suction, in order to evacuate various liquids and/or solids which exist in the body cavity and interfere with the inspection.

Tip section 304 may further include therein a side-pointing camera 316 which may
15 capture images through a hole in a cylindrical surface 305 of the tip section. A discrete side illuminator 322, which is optionally similar to discrete front illuminator 308, may be associated with front-pointing camera 304 and used for illuminating its field of view through another hole in cylindrical surface 305. In a different configuration (not shown), two or more discrete side illuminators may be present in the tip section, such as for supplying overall
20 stronger illumination and/or for increasing the angular coverage of the illumination. These two or more discrete side illuminators may be located next to one another so that they share a same protective window on the cylindrical surface of the tip section.

A side fluid injector 320 may be used for cleaning at least one of side-pointing camera 304 and discrete side illuminator 322. In order to prevent tissue damage when cylindrical
25 surface 305 of tip section 304 contacts a side wall of the body cavity, side fluid injector 320 and side-pointing camera 316 may be located in a depression 318 in the cylindrical surface. This way, side fluid injector 320 may be elevated from depression 318 but still not significantly protrude from the level of cylindrical surface 305. The elevation of side fluid injector 320 may enable it to inject fluid, from its side 320a, onto side-pointing camera 316.
30 In an alternative configuration (not shown), one or more discrete side illuminators may also be included in the depression, so that fluid injected from the side fluid injector may reach

them. In yet another configuration (not shown), a side-pointing camera, one or more side illuminators and a side fluid injector may not be located in a depression, but rather be on essentially the same level as the cylindrical surface of the tip section.

Reference is now made to Fig. 4, which shows a cross-sectional view of a bending section 400 of a multi-camera endoscope, such as multi-camera endoscope 300 of Fig. 3. A plurality of steering cable eyes, such as four eyes 408, are positioned on the internal walls of bending section 400. Through these eyes 408, steering cables are threaded, to enable the maneuvering of bending section 400. Bending section 400 may also include a working channel 402, through which surgical tools may be inserted, a fluid channel 406, through which fluids and/or liquids may be infused, and an electrical channel 404, through which a plurality of electrical cables may be threaded, for transmitting video signals from the cameras and for supplying power to the cameras and the discrete illuminators.

For simplicity of presentation, Fig. 4 only shows a single working channel 402, although in a different configuration (not shown), more than one working channel may exist, to enable the insertion of multiple surgical tools simultaneously. Similarly, only one fluid channel 406 is shown, although in a different configuration (not shown) more than one fluid channel may be used, such as for separately feeding at least one of a front fluid injector, a side fluid injector and/or a pathway fluid injector, as well as for separately providing suction through the pathway fluid injector. Additionally, Fig. 4 shows only a single electrical channel 404, but in other configurations (not shown), one or more of the electrical cables threaded through the elongated shaft and/or the bending section may be separated into a plurality of tubes, for example in order to distance cables causing magnetic induction from cables which may be influenced by this phenomena.

Reference is now made to Fig. 5A, which shows a cross-sectional view of a tip section 500a of a multi-camera endoscope, according to an embodiment. Tip section 500a may include a front-pointing image sensor 502, such as Charge Coupled Device (CCD) or a Complementary Metal Oxide Semiconductor (CMOS) image sensor. Front-pointing image sensor 502 may be mounted on an integrated circuit board 506, which may be rigid or flexible. Integrated circuit board 506 may supply front-pointing image sensor 502 with the necessary electrical power, and may derive still images and/or video feeds captured by the image sensor. Integrated circuit board 506 may be connected to a set of electrical cables (not

shown) which may be threaded through an electrical channel running through the elongated shaft of the endoscope. Front-pointing image sensor 502 may have a lens assembly 504 mounted on top of it and providing the necessary optics for receiving images. Lens assembly 504 may include a plurality of lenses, static or movable, which may provide a field of view of at least 90 degrees and up to essentially 180 degrees. Lens assembly 504 may provide a focal length of about 3 to 100 millimeters. Front-pointing image sensor 502 and lens assembly 504, with or without integrated circuit board 506, may be jointly referred to as a “front pointing camera”.

One or more discrete front illuminators 508 may be placed next to lens assembly 504, for illuminating its field of view. Optionally, discrete front illuminators 508 may be attached to the same integrated circuit board 506 on which front-pointing image sensor 502 is mounted (this configuration is not shown).

Tip section 500a may include a side-pointing image sensor 512, such as Charge Coupled Device (CCD) or a Complementary Metal Oxide Semiconductor (CMOS) image sensor. Front-pointing image sensor 512 may be mounted on an integrated circuit board 516, which may be rigid or flexible. Integrated circuit board 516 may supply side-pointing image sensor 512 with the necessary electrical power, and may derive still images and/or video feeds captured by the image sensor. Integrated circuit board 516 may be connected to a set of electrical cables (not shown) which may be threaded through an electrical channel running through the elongated shaft of the endoscope.

Side-pointing image sensor 512 may have a lens assembly 514 mounted on top of it and providing the necessary optics for receiving images. Lens assembly 514 may include a plurality of lenses, static or movable, which may provide a field of view of at least 90 degrees and up to essentially 180 degrees. Lens assembly 514 may provide a focal length of about 2 to 33 millimeters. Side-pointing image sensor 512 and lens assembly 514, with or without integrated circuit board 516, may be jointly referred to as a “side pointing camera”.

One or more discrete side illuminators 518 may be placed next to lens assembly 514, for illuminating its field of view. Optionally, discrete side illuminators 518 may be attached to the same integrated circuit board 516 on which side-pointing image sensor 512 is mounted (this configuration is not shown).

In another configuration (not shown), integrated circuit boards 506 and 516 may be a single integrated circuit board on which both front and side-pointing image sensors 502 and 512 are mounted. For this purpose, the integrated circuit board may be essentially L-shaped.

5 Front and side-pointing image sensors 502 and 512 may be similar or identical in terms of, for example, field of view, resolution, light sensitivity, pixel size, focal length, focal distance and/or the like.

10 Optionally, side-pointing image sensor 512 and lens assembly 514 are advantageously positioned relatively close to the distal end surface of tip section 500a. For example, a center of the side-pointing camera (which is the center axis of side-pointing image sensor 512 and lens assembly 514) is positioned approximately 7 to 11 millimeters from the distal end of the tip section. This is enabled by an advantageous miniaturizing of the front and side-pointing cameras, which allows for enough internal space in the tip section for angular positioning of the cameras without colliding.

15 Reference is now made to Fig. 5B, which shows a cross-sectional view of a tip section 500b of a multi-camera endoscope, according to another embodiment of the invention. Tip section 500b, similar to tip section 500a of Fig. 5A, may include a front-pointing image sensor 502, such as Charge Coupled Device (CCD) or a Complementary Metal Oxide Semiconductor (CMOS) image sensor. Front-pointing image sensor 502 may be mounted on an integrated circuit board 506, which may be rigid or flexible. Integrated circuit board 506 may supply front-pointing image sensor 502 with the necessary electrical power, and may derive still images and/or video feeds captured by the image sensor. Integrated circuit board 506 may be connected to a set of electrical cables (not shown) which may be threaded through an electrical channel running through the elongated shaft of the endoscope. Front-pointing image sensor 502 may have a lens assembly 504 mounted on top of it and providing the necessary optics for receiving images. Lens assembly 504 may include a plurality of lenses, static or movable, which may provide a field of view of at least 90 degrees and up to essentially 180 degrees. Lens assembly 504 may provide a focal length of about 3 to 100 millimeters. Front-pointing image sensor 502 and lens assembly 504, with or without integrated circuit board 506, may be jointly referred to as a "front pointing camera". One or more discrete front illuminators 508 may be placed next to lens assembly 504, for illuminating its field of view. Optionally, discrete front illuminators 508 may be attached to

20
25
30

the same integrated circuit board 506 on which front-pointing image sensor 502 is mounted (this configuration is not shown).

Tip section 500b may include, in addition to side-pointing image sensor 512a, another side-pointing image sensor 512b. Side-pointing image sensors 512a and 512b may include
5 Charge Coupled Device (CCD) or a Complementary Metal Oxide Semiconductor (CMOS) image sensor. Side-pointing image sensors 512a and 512b may be mounted on integrated circuit boards 516a and 516b, respectively, which may be rigid or flexible. Integrated circuit boards 516a and 516b may supply side-pointing image sensors 512a and 512b with the necessary electrical power, and may derive still images and/or video feeds captured by the
10 image sensor. Integrated circuit boards 516a and 516b may be connected to a set of electrical cables (not shown) which may be threaded through an electrical channel running through the elongated shaft of the endoscope.

Side-pointing image sensors 512a and 512b may have lens assemblies 514a and 514b, respectively, mounted on top of them and providing the necessary optics for receiving
15 images. Lens assemblies 514a and 514b may include a plurality of lenses, static or movable, which may provide a field of view of at least 90 degrees and up to essentially 180 degrees. Lens assemblies 514a and 514b may provide a focal length of about 2 to 33 millimeters. Side-pointing image sensors 512a and 512b and lens assemblies 514a and 514b, with or without integrated circuit boards 516a and 516b, respectively, may be jointly referred to as a
20 “side pointing cameras”.

Discrete side illuminators 518a and 518b may be placed next to lens assemblies 514a and 514b, respectively, for illuminating its field of view. Optionally, discrete side illuminators 518a and 518b may be attached to the same integrated circuit boards 516a and 516b on which side-pointing image sensors 512a and 512 b are mounted (this configuration is
25 not shown).

In another configuration (not shown), integrated circuit boards 506, 516a and 516b may be a single integrated circuit board on which front and side-pointing image sensors 502, 512a and 512b are mounted.

Front and side-pointing image sensors 502, 512a and 512b may be similar, identical or distinct in terms of, for example, field of view, resolution, light sensitivity, pixel size, focal length, focal distance and/or the like.

Optionally, side-pointing image sensors 512a and 512b and lens assemblies 514a and 514b are advantageously positioned relatively close to the distal end surface of tip section 500b. For example, a center of the side-pointing cameras (which is the center axis of side-pointing image sensors 512a and 512b and lens assemblies 514a and 514b) is positioned approximately 7 to 11 millimeters from the distal end of the tip section. This is enabled by an advantageous miniaturizing of the front and side-pointing cameras, which allows for enough internal space in the tip section for angular positioning of the cameras without colliding.

According to some embodiments, the front and side-pointing cameras are all positioned on the same (imaginary) plain which "divides" tip section 500b into two equal parts along its length. According to some embodiments, each of the side-pointing cameras is perpendicular to the front pointing camera.

Reference is now made to Fig. 6, which shows a semi-pictorial view multi-camera endoscopy system 600. System 600 may include a multi-camera endoscope 602, such as the endoscope of Figs. 2, 3, 4 and/or 5. Multi-camera endoscope 602 may include a handle 604, from which an elongated shaft 606 emerges. Elongated shaft 606 terminates with a tip section 608 which is turnable by way of a bending section 610. Handle 604 may be used for maneuvering elongated shaft 606 within a body cavity; the handle may include one or more knobs and/or switches 605 which control bending section 610 as well as functions such as fluid injection and suction. Handle 604 may further include a working channel opening 612 through which surgical tools may be inserted.

A utility cable 614 may connect between handle 604 and a controller 616. Utility cable 614 may include therein one or more fluid channels and one or more electrical channels. The electrical channel(s) may include at least one data cable for receiving video signals from the front and side-pointing cameras, as well as at least one power cable for providing electrical power to the cameras and to the discrete illuminators.

Controller 616 may govern power transmission to the endoscope's 602 tip section 608, such as for the tip section's cameras and illuminators. Controller 616 may further control one

or more fluid, liquid and/or suction pump which supply corresponding functionalities to endoscope 602. One or more input devices, such as a keyboard 618, may be connected to controller 616 for the purpose of human interaction with the controller. In another configuration (not shown), an input device, such as a keyboard, may be integrated with the controller in a same casing.

A display 620 may be connected to controller 616, and configured to display images and/or video streams received from the cameras of multi-camera endoscope 602. Display 620 may further be operative to display a user interface for allowing a human operator to set various features of system 600.

Optionally, the video streams received from the different cameras of multi-camera endoscope 602 may be displayed separately on display 620, either side-by-side or interchangeably (namely, the operator may switch between views from the different cameras manually). Alternatively, these video streams may be processed by controller 616 to combine them into a single, panoramic video frame, based on an overlap between fields of view of the cameras.

In another configuration (not shown), two or more displays may be connected to controller 616, each for displaying a video stream from a different camera of the multi-camera endoscope.

Reference is now made to Figs. 7A-D, in which multiple configurations 700, 720, 740 and 760 of a tip section are shown.

In configuration 700, a front-pointing camera 702 and a side-pointing camera 704 are essentially perpendicular to one another, and have, correspondingly, perpendicular fields of view.

In configuration 720, a front-pointing camera 722 is essentially perpendicular to a first side-pointing camera 724 and a second side-pointing camera 726. First and second side-pointing cameras 724-726 are pointing perpendicularly to one another, and are positioned essentially 90 degrees apart in the cylindrical surface of the tip section. In another configuration (not shown), a first and a second side-pointing cameras may be positioned more than 90 degrees apart in the cylindrical surface of the tip section, such as 120-150 degrees

apart or 150-180 degrees apart. For example, the first and second side-pointing cameras may be positioned in 180 degrees apart, in opposite sides of the cylindrical surface of the tip section, so that they point in opposite directions. In yet further configurations (not shown), three or more side-pointing cameras may be positioned in the cylindrical surface of the tip section, for example, three cameras having 120 degrees in between them.

In configuration 740, a side-pointing camera 744 is pointing slightly backwards, so that it forms an angle larger than 90 degrees relative to a front-pointing camera 742. As an example, an angle of 120 degrees is shown. In another configuration (not shown), the angle is 100-145 degrees.

In configuration 760, two opposing side cameras, 764 and 766, are shown, which are pointing slightly backwards, so that they each form an angle larger than 90 degrees relative to a front-pointing camera 762. As an example, an angle of 120 degrees is shown. In another configuration (not shown), the angle is 100-145 degrees.

Similarly, in other configurations (not shown), three or more side-pointing cameras may be positioned in the cylindrical surface of the tip section, each pointing slightly backwards and having an certain angle in between; in the case of three cameras, they may have an angle of 120 degrees in between them.

Reference is now made to Fig. 8, which shows a perspective view of a multi-camera endoscope, according to some embodiments. Endoscope 800 includes an elongated shaft 802 which typically includes a bending section (not shown) and a tip section 804 which terminates the endoscope. Tip section 804 includes three side-pointing cameras 816a, 816b (not shown) and 816c (not shown). Discrete side illuminators (for example LEDs), not shown, may be associated with the side-pointing cameras 816a-c for illuminating their respective fields of view 817a-c. Tip section 804 includes further includes a working channel 812 which may be a hollow opening configured for insertion of a surgical tool to operate on various tissues. For example, miniature forceps may be inserted through working channel 812 in order to remove a polyp or sample of which for biopsy.

Tip 804 may further include other elements/components, (for example, as described herein according to various embodiments) such as fluid injector(s) for cleaning the cameras

and/or there illuminators and pathway fluid injector(s) for inflating and/or cleaning the body cavity into which endoscope 800 is inserted.

Reference is now made to Fig. 9, which shows a perspective view of a multi-camera endoscope, according to some embodiments. Endoscope 900 is similar to endoscope 800 how
5 ever does not include a working channel. Elongated shaft 902, tip section 904, side-pointing cameras 916a, 916b (not shown) and 916c (not shown), and their respective fields of view 917a-c may be similar to elongated shaft 802, tip section 804, side-pointing cameras 816a, 816b (not shown) and 816c (not shown), and their respective fields of view 817a-c of endoscope 800.

10 While a number of exemplary aspects and embodiments have been discussed above, those of skill in the art will recognize certain modifications, permutations, additions and sub-combinations thereof. It is therefore intended that the following appended claims and claims hereafter introduced be interpreted to include all such modifications, permutations, additions and sub-combinations as are within their true spirit and scope.

15 In the description and claims of the application, each of the words “comprise” “include” and “have”, and forms thereof, are not necessarily limited to members in a list with which the words may be associated.

CLAIMS

What is claimed is:

1. A tip section of a multi-camera endoscope, the tip section comprising:
 - a front-pointing camera and a discrete front illuminator associated therewith;
 - 5 two or more side-pointing cameras positioned at or in proximity to a distal end of said tip section, wherein each of said two or more side-pointing cameras having a discrete side illuminator associated therewith; and
 - a working channel configured for insertion of a surgical tool.
2. The tip section according to claim 1, further comprising a pathway fluid injector for
10 inflating and/or cleaning a body cavity into which the endoscope is inserted.
3. The tip section according to claim 1, further comprising a fluid injector configured for cleaning said front-pointing camera and/or said discrete front illuminator.
4. The tip section according to claim 1, further comprising two or more side fluid injectors configured for cleaning said two or more side-pointing cameras and/or said discrete
15 side illuminators.
5. The tip section according to claim 1, comprising two side-pointing cameras.
6. The tip section according to claim 1, comprising two side-pointing cameras pointing at directions essentially opposing to one another.
7. The tip section according to claim 1, comprising three or more side-pointing cameras
20 positioned essentially at equal distances from each other along the perimeter of said tip section.
8. The tip section according to claim 1, wherein said discrete front illuminator comprises a light-emitting diode (LED).
9. The tip section according to claim 1, wherein each of said discrete side illuminators
25 comprises a light-emitting diode (LED).

10. The tip section according to claim 1, wherein each of said discrete front and side illuminators comprises a light-emitting diode (LED).
11. The tip section according to claim 1, wherein said endoscope is a colonoscope.
12. A multi-camera endoscope comprising:
- 5 an elongated shaft terminating with a tip section turnable by way of a bending section, wherein said tip section comprises:
- a front-pointing camera and a discrete front illuminator associated therewith;
- two or more side-pointing cameras positioned at or in proximity to a distal end of said tip section, wherein each of said two or more side-pointing cameras having a discrete side illuminator associated therewith; and
- 10 a working channel configured for insertion of a surgical tool.
13. The endoscope according to claim 12, wherein said tip section further comprises a pathway fluid injector for inflating and/or cleaning a body cavity into which the endoscope is
- 15 inserted.
14. The endoscope according to claim 12, wherein said tip section further comprises a fluid injector configured for cleaning said front-pointing camera and/or said discrete front illuminator.
15. The endoscope according to claim 12, wherein said tip section further comprises two
- 20 or more side fluid injectors configured for cleaning said two or more side-pointing cameras and/or said discrete side illuminators.
16. The endoscope according to claim 12, wherein said tip section comprises two side-pointing cameras.
17. The endoscope according to claim 12, wherein said tip section comprises two side-
- 25 pointing cameras pointing at directions essentially opposing to one another.

18. The endoscope according to claim 12, wherein said tip section comprises three or more side-pointing cameras positioned essentially at equal distances from each other along the perimeter of said tip section.
19. The endoscope according to claim 12, wherein said discrete front illuminator
5 comprises a light-emitting diode (LED).
20. The endoscope according to claim 12, wherein each of said discrete side illuminators comprises a light-emitting diode (LED).
21. The endoscope according to claim 12, wherein each of said discrete front and side illuminators comprises a light-emitting diode (LED).
- 10 22. The endoscope according to claim 12, wherein said endoscope is a colonoscope.

1/8

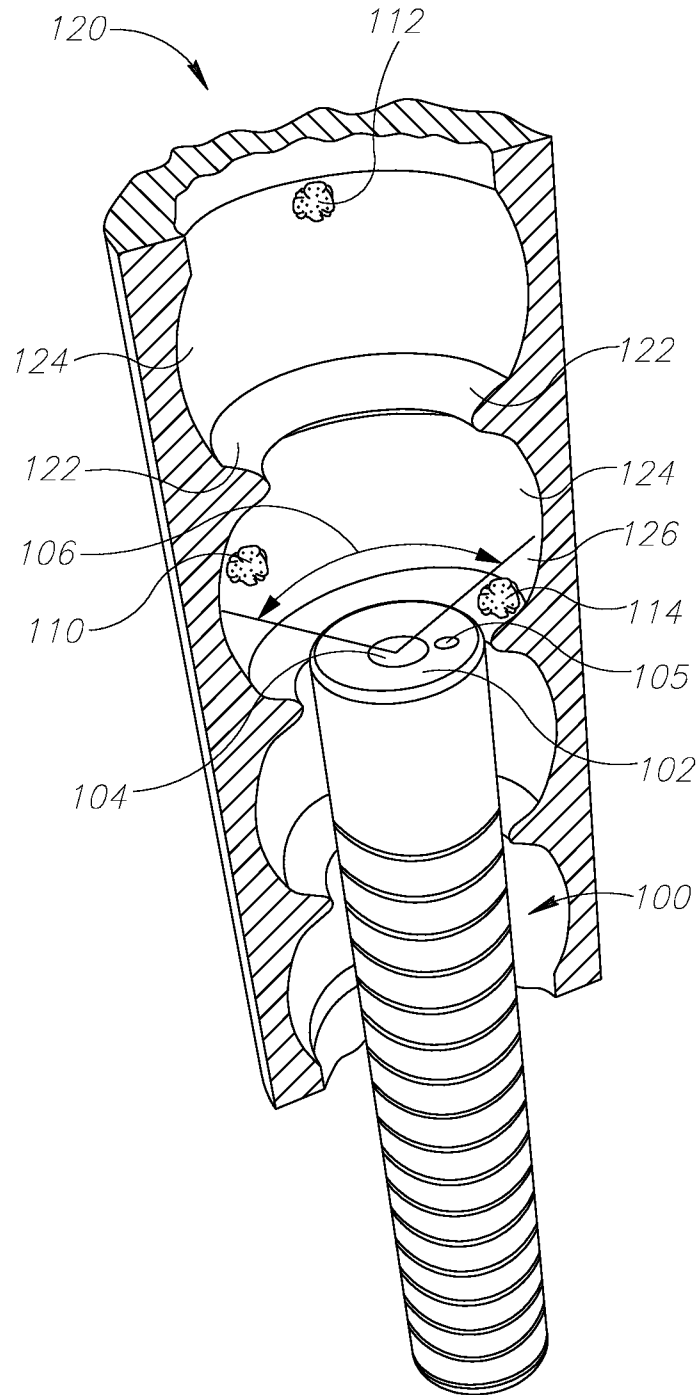

FIG. 1

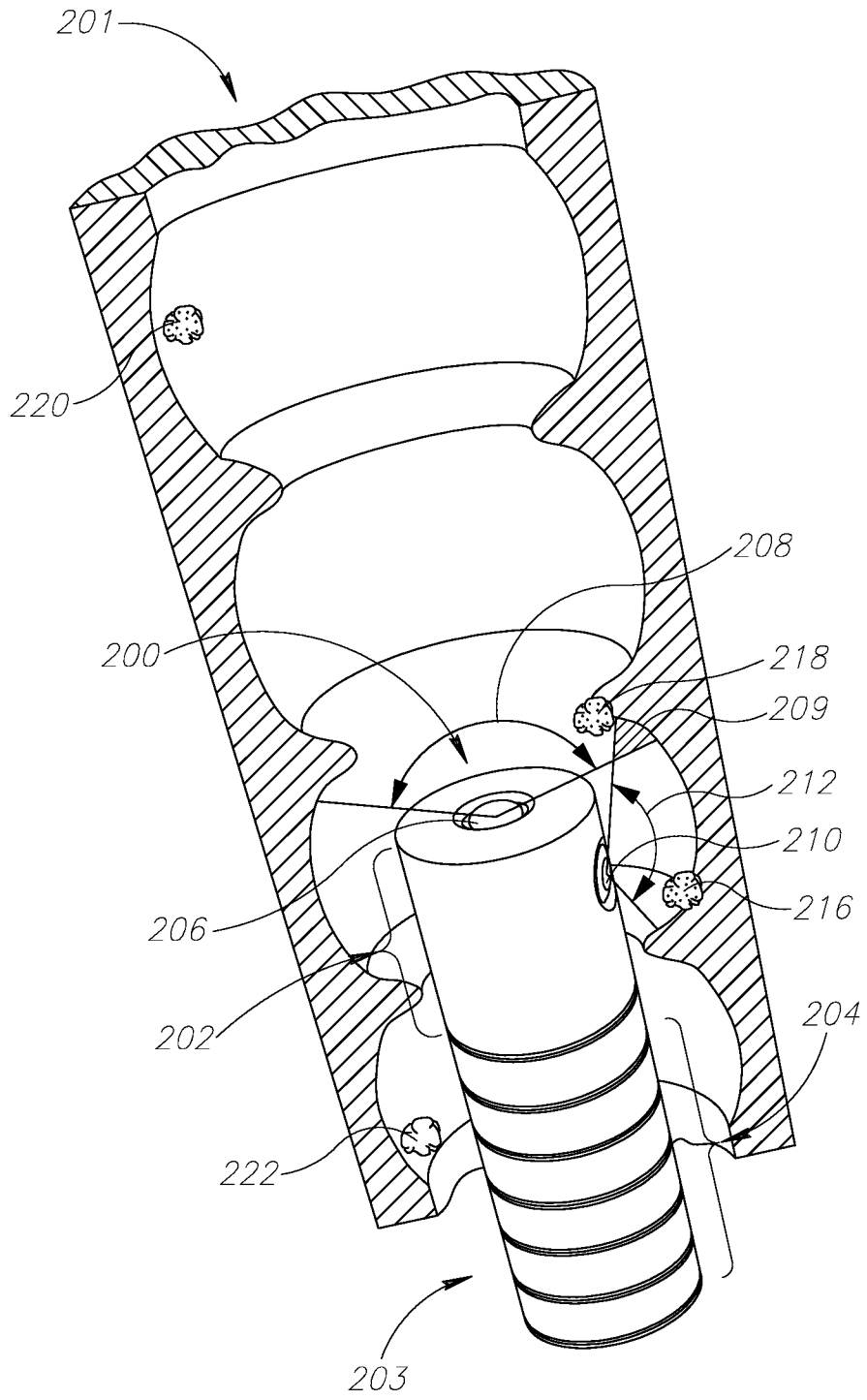

FIG. 2

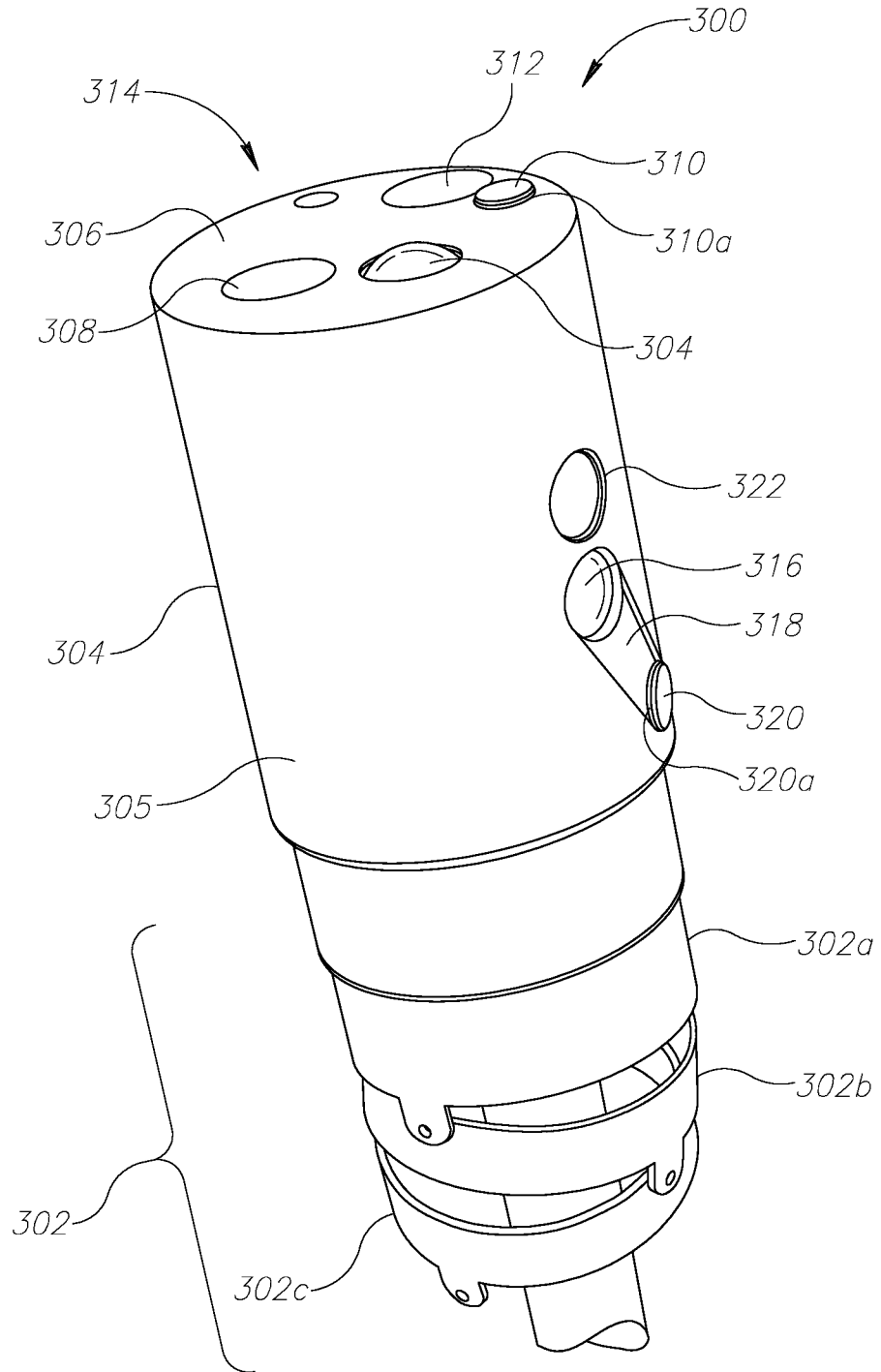

FIG.3

4/8

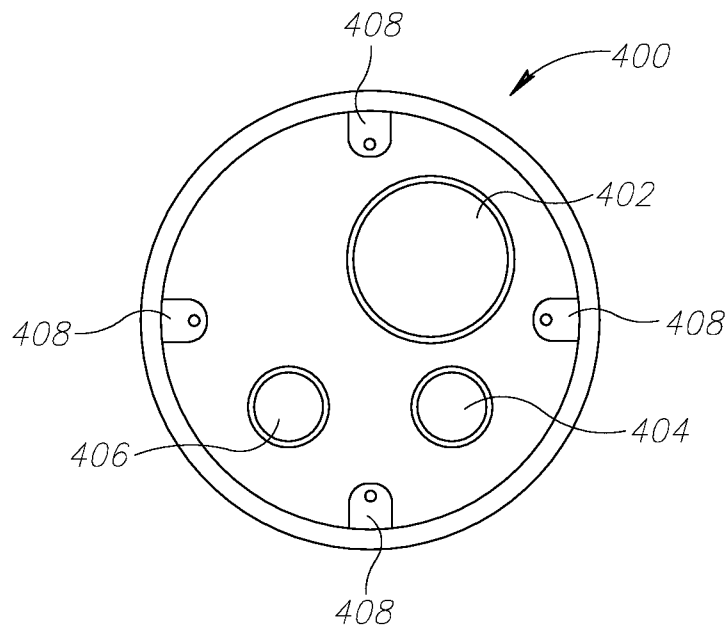

FIG. 4

5/8

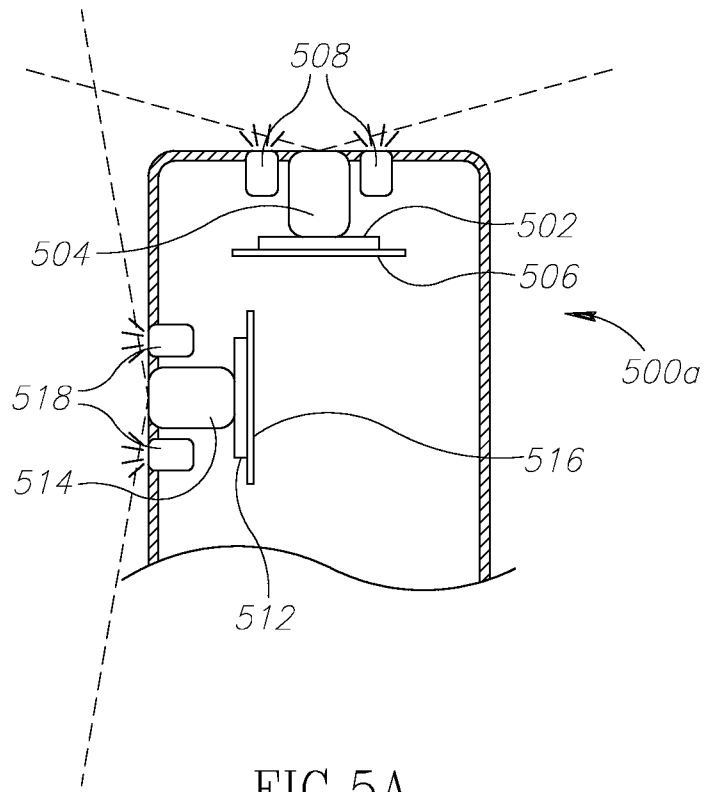

FIG. 5A

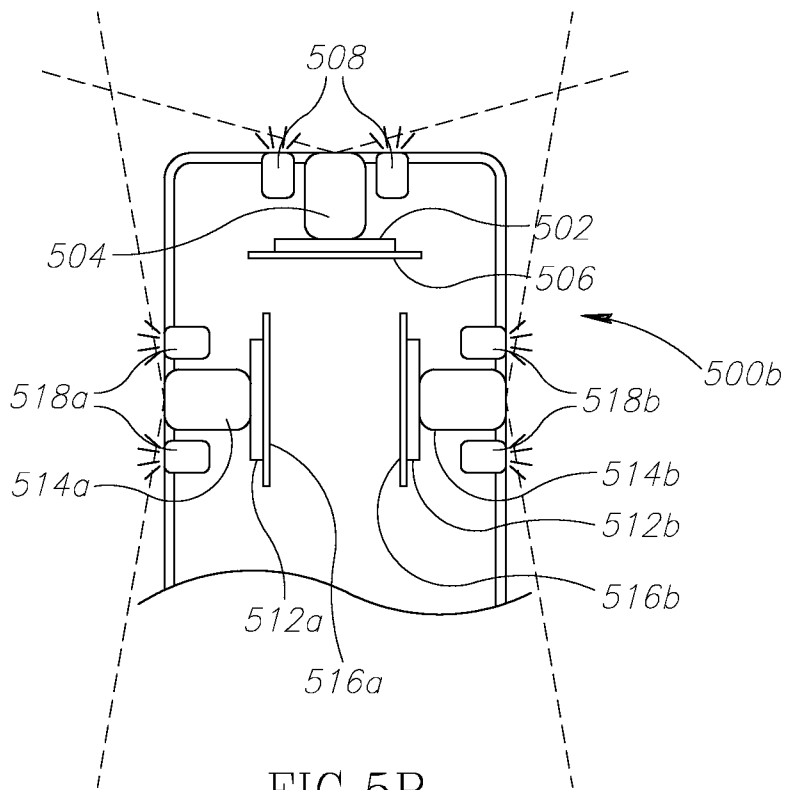

FIG. 5B

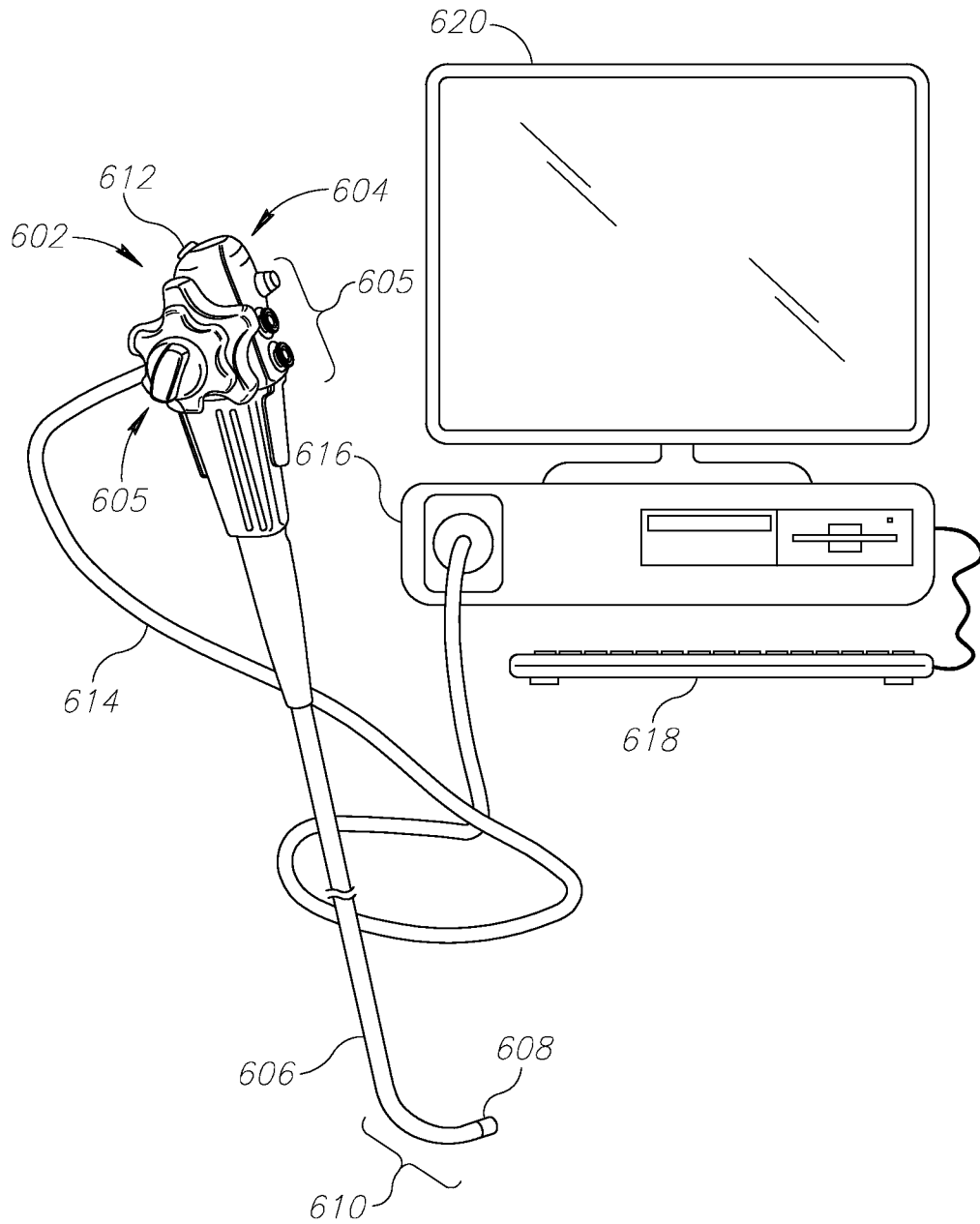

FIG. 6

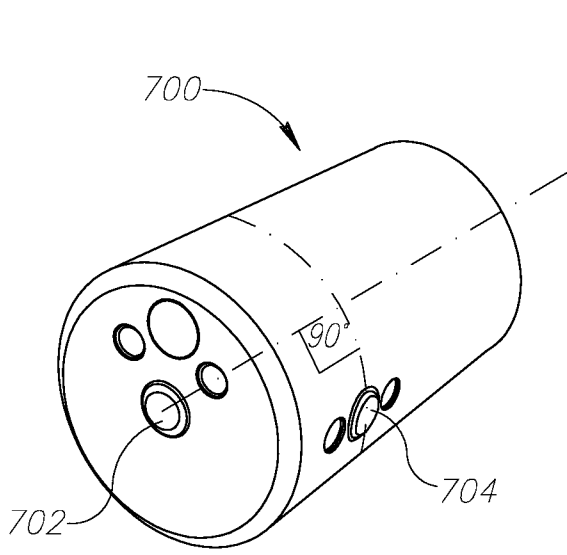

FIG. 7A

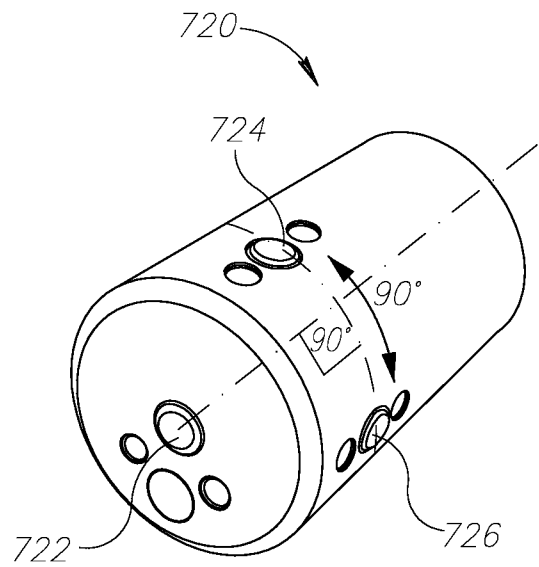

FIG. 7B

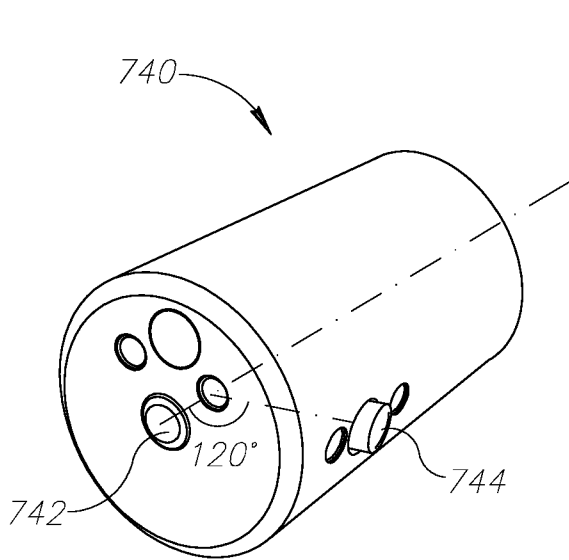

FIG. 7C

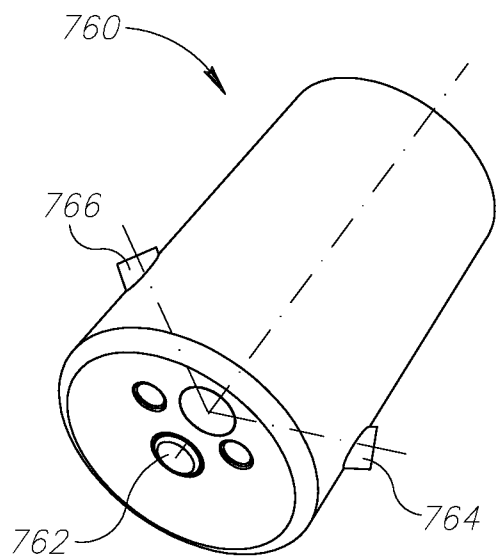

FIG. 7D

8/8

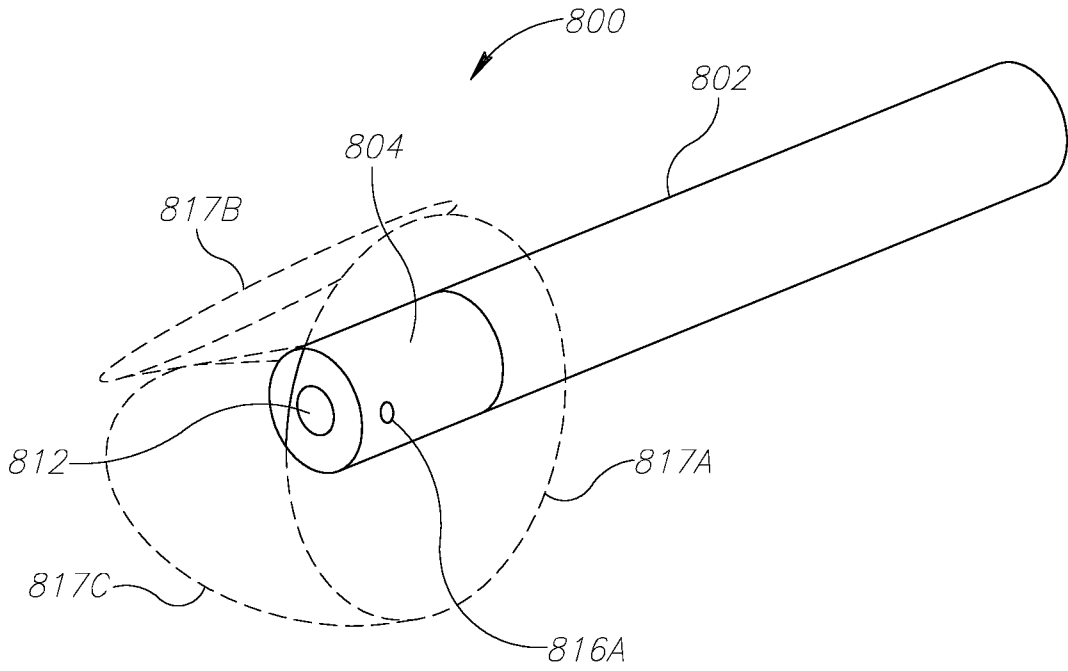

FIG. 8

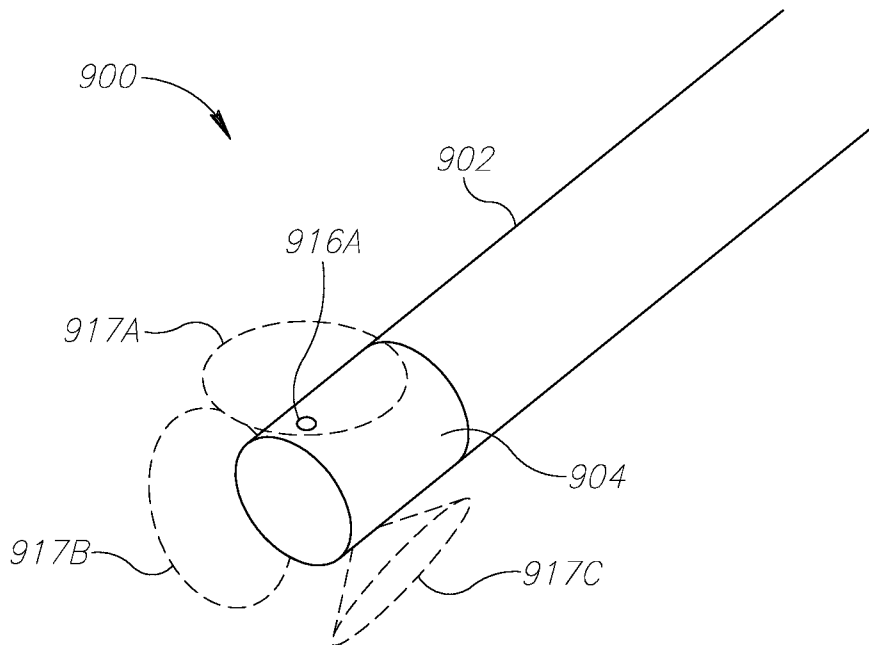

FIG. 9

INTERNATIONAL SEARCH REPORT

International application No.

PCT/IL2013/050840

A. CLASSIFICATION OF SUBJECT MATTER IPC (2013.01) A61B 1/05, A61B 1/005, A61B 1/06		
According to International Patent Classification (IPC) or to both national classification and IPC		
B. FIELDS SEARCHED		
Minimum documentation searched (classification system followed by classification symbols) IPC (2013.01) A61B		
Documentation searched other than minimum documentation to the extent that such documents are included in the fields searched		
Electronic data base consulted during the international search (name of data base and, where practicable, search terms used) Databases consulted: Esp@cenet, Google Patents, FamPat database Search terms used: multi, cameras, endoscope, peer medical, side, views, sideways		
C. DOCUMENTS CONSIDERED TO BE RELEVANT		
Category*	Citation of document, with indication, where appropriate, of the relevant passages	Relevant to claim No.
X	US 2011263938 A1 LEVY AVI 27 Oct 2011 (2011/10/27) the whole document	1-22
X	US 2012232340 A1 PEER MEDICAL LTD 13 Sep 2012 (2012/09/13) the whole document	1-22
X	US 2012229615 A1 PEER MEDICAL LTD 13 Sep 2012 (2012/09/13) the whole document	1-22
<input type="checkbox"/> Further documents are listed in the continuation of Box C. <input checked="" type="checkbox"/> See patent family annex.		
* Special categories of cited documents: "A" document defining the general state of the art which is not considered to be of particular relevance "E" earlier application or patent but published on or after the international filing date "L" document which may throw doubts on priority claim(s) or which is cited to establish the publication date of another citation or other special reason (as specified) "O" document referring to an oral disclosure, use, exhibition or other means "P" document published prior to the international filing date but later than the priority date claimed "T" later document published after the international filing date or priority date and not in conflict with the application but cited to understand the principle or theory underlying the invention "X" document of particular relevance; the claimed invention cannot be considered novel or cannot be considered to involve an inventive step when the document is taken alone "Y" document of particular relevance; the claimed invention cannot be considered to involve an inventive step when the document is combined with one or more other such documents, such combination being obvious to a person skilled in the art "&" document member of the same patent family		
Date of the actual completion of the international search 04 Feb 2014	Date of mailing of the international search report 04 Feb 2014	
Name and mailing address of the ISA: Israel Patent Office Technology Park, Bldg.5, Malcha, Jerusalem, 9695101, Israel Facsimile No. 972-2-5651616	Authorized officer LEVI Moria Telephone No. 972-5651753	

INTERNATIONAL SEARCH REPORT
Information on patent family members

International application No. PCT/IL2013/050840
--

Patent document cited search report	Publication date	Patent family member(s)	Publication Date
US 2011263938 A1	27 Oct 2011	CA 2765559 A1	23 Dec 2010
		EP 2442706 A1	25 Apr 2012
		EP 2442706 A4	19 Dec 2012
		IL 217042 D0	01 Mar 2012
		US 2011263938 A1	27 Oct 2011
		US 2012053407 A1	01 Mar 2012
		US 2012065468 A1	15 Mar 2012
		US 2013109916 A1	02 May 2013
		WO 2010146587 A1	23 Dec 2010
		WO 2013014673 A1	31 Jan 2013
		WO 2013024476 A1	21 Feb 2013
<hr/>			
US 2012232340 A1	13 Sep 2012	US 2012232340 A1	13 Sep 2012
<hr/>			
US 2012229615 A1	13 Sep 2012	US 2012229615 A1	13 Sep 2012
<hr/>			