

FIG. 1

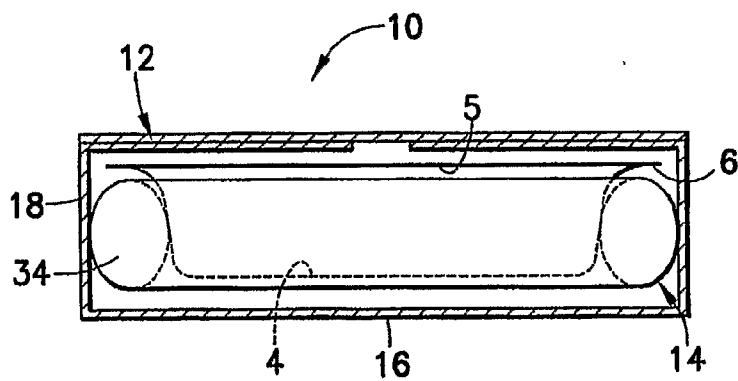
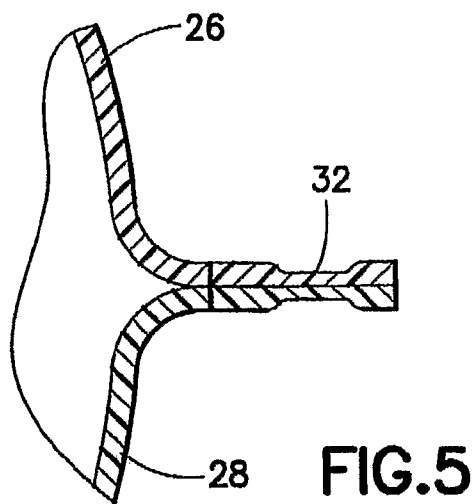
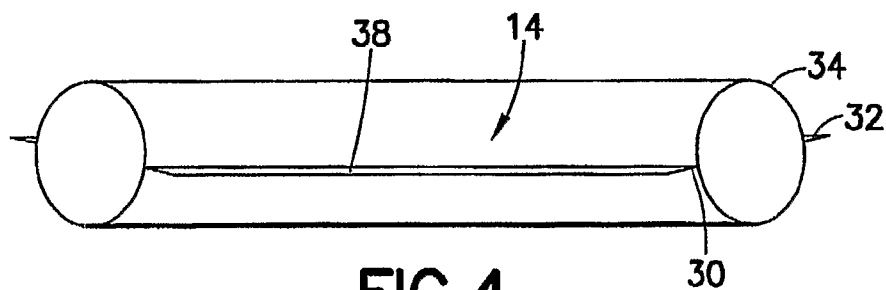
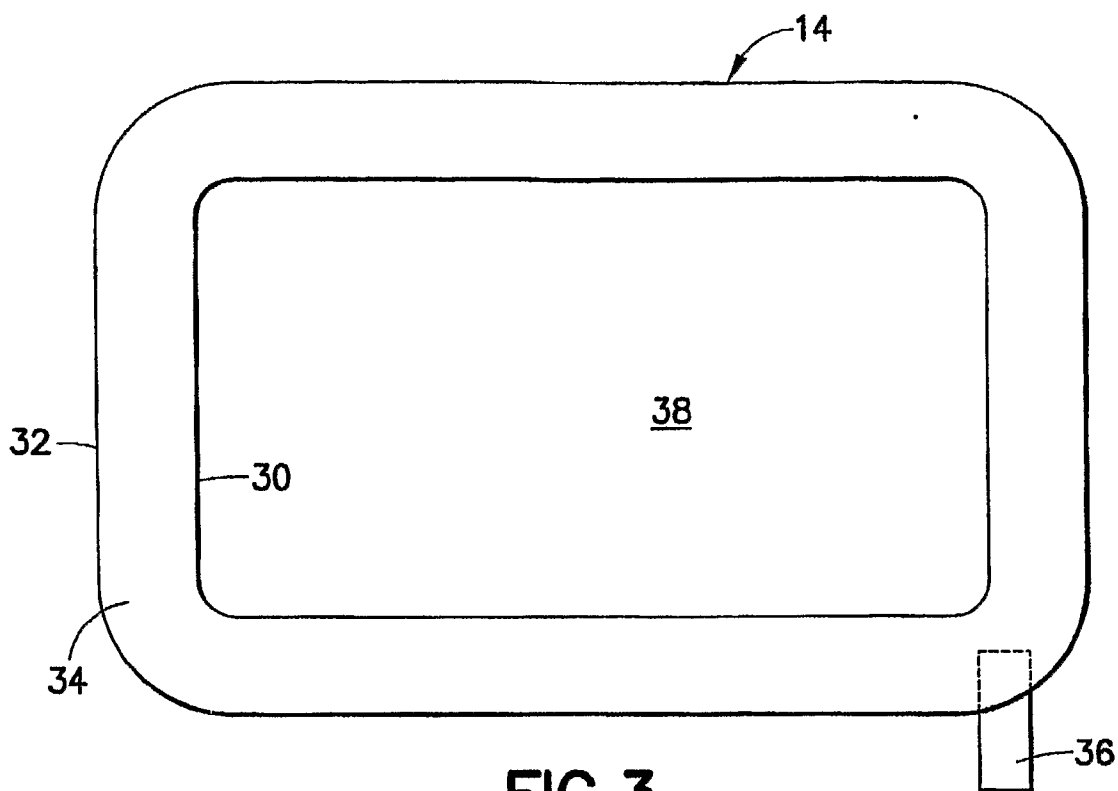

FIG. 2



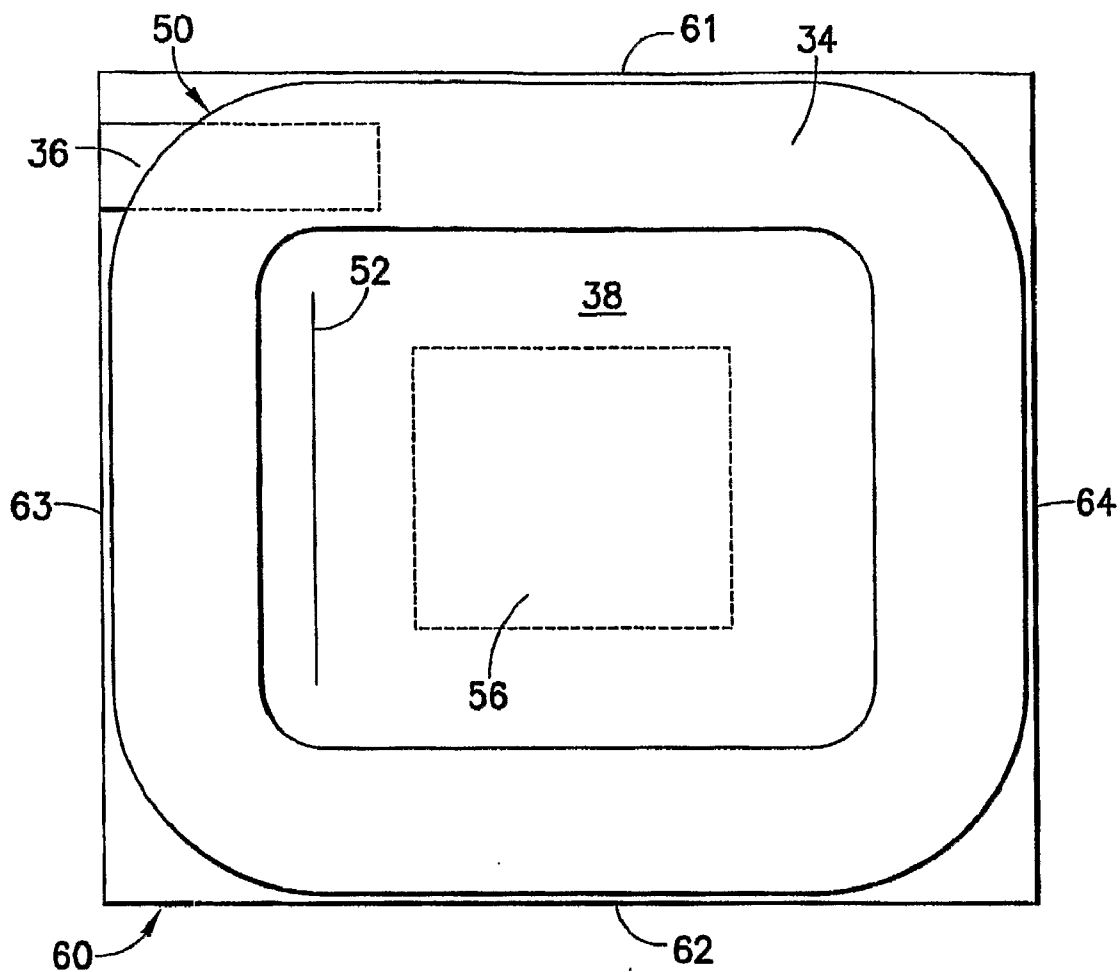

FIG. 6

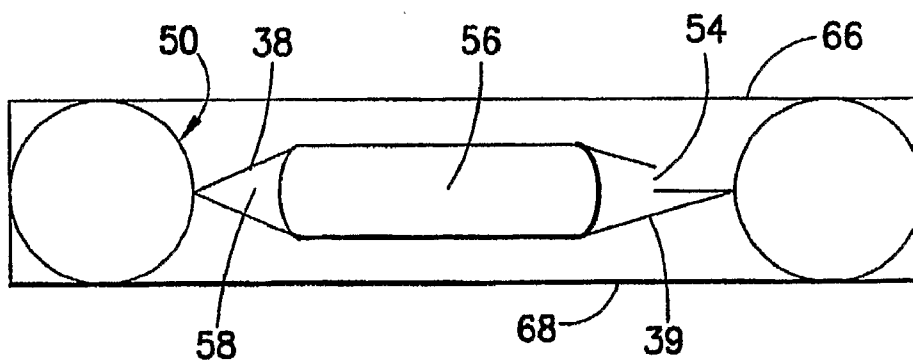

FIG. 7

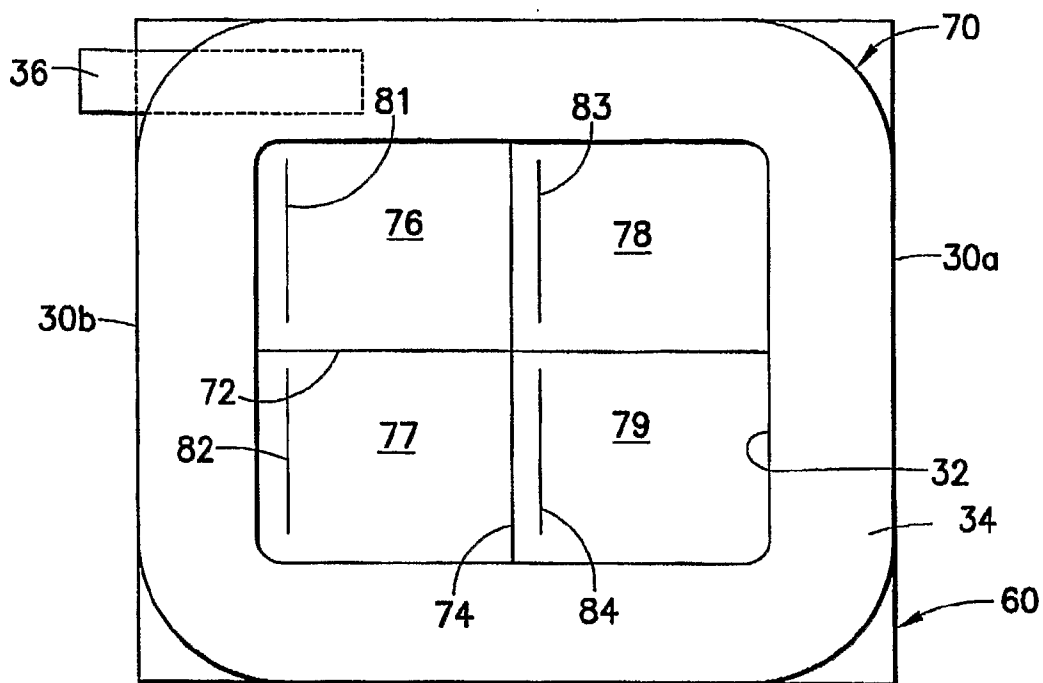

FIG. 8

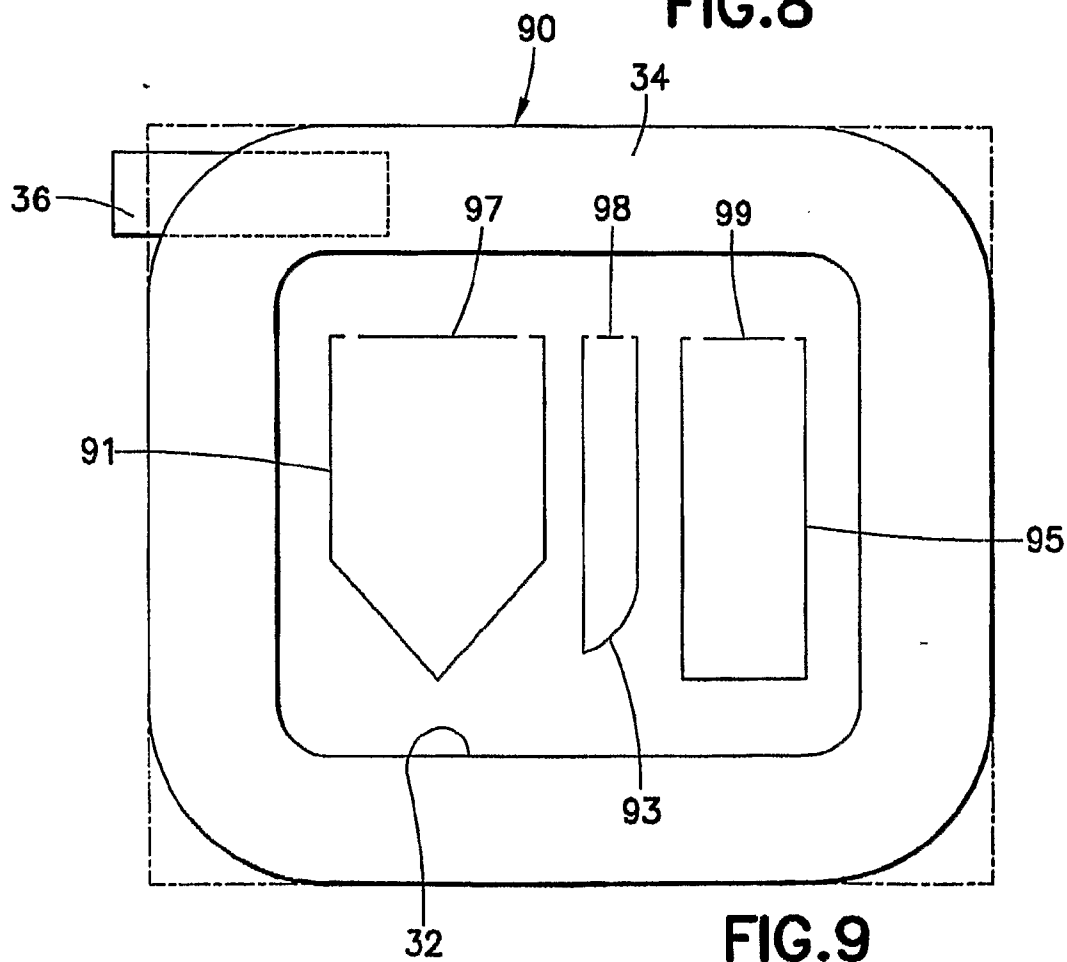

FIG. 9

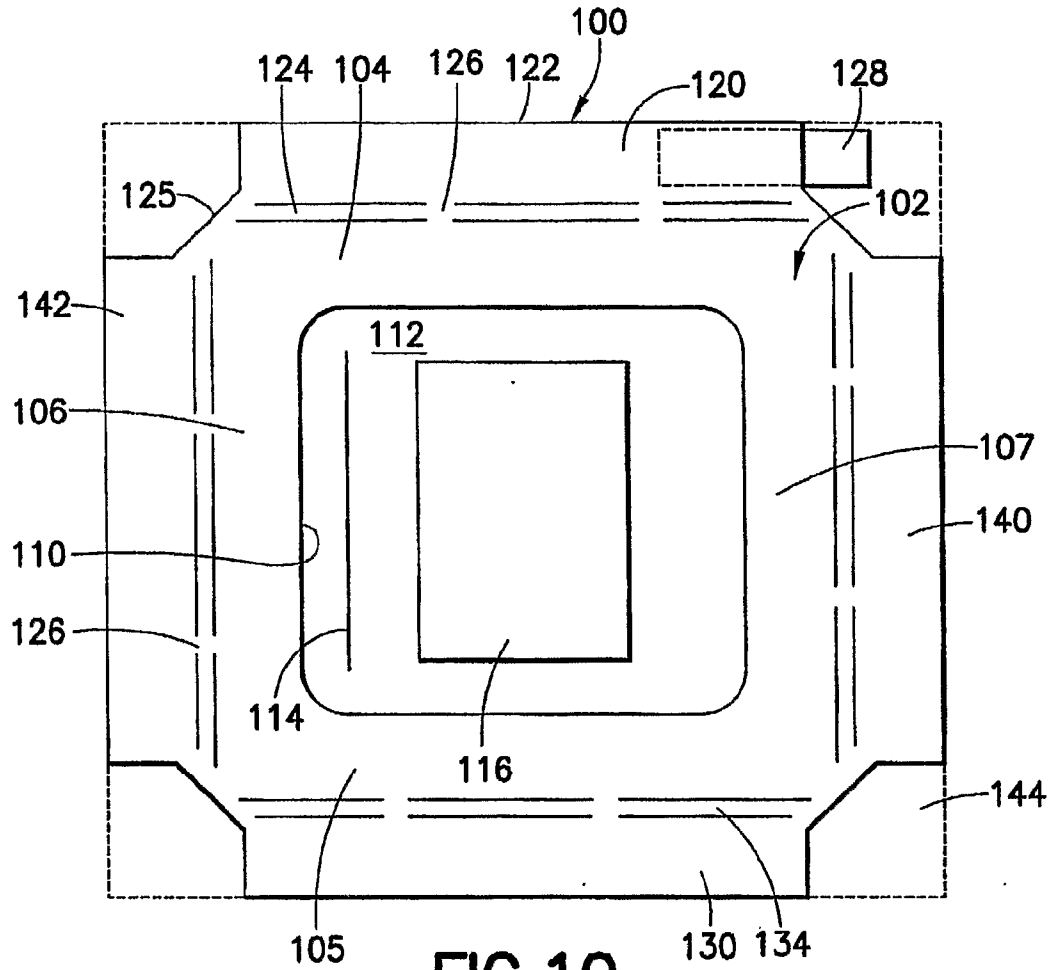

FIG. 10

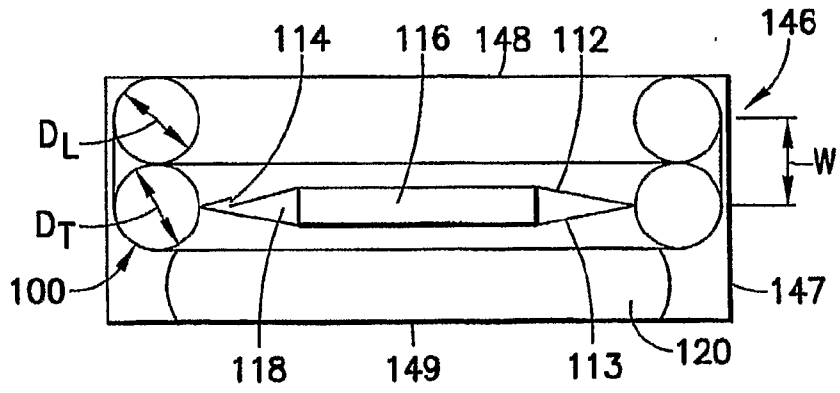

FIG. 11

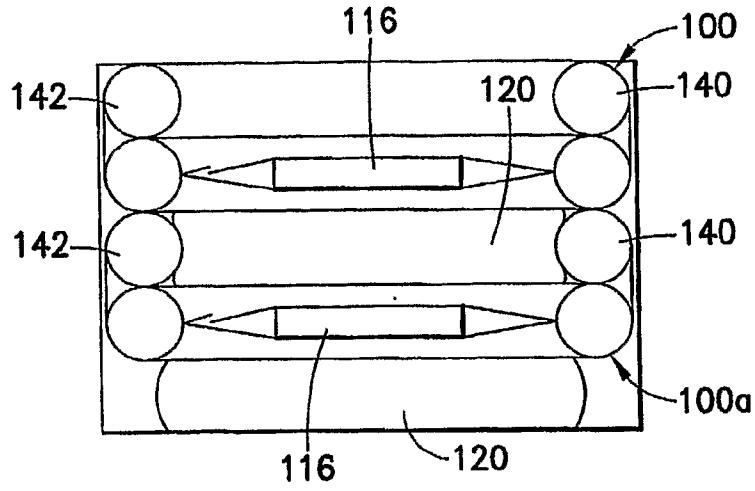

FIG. 12

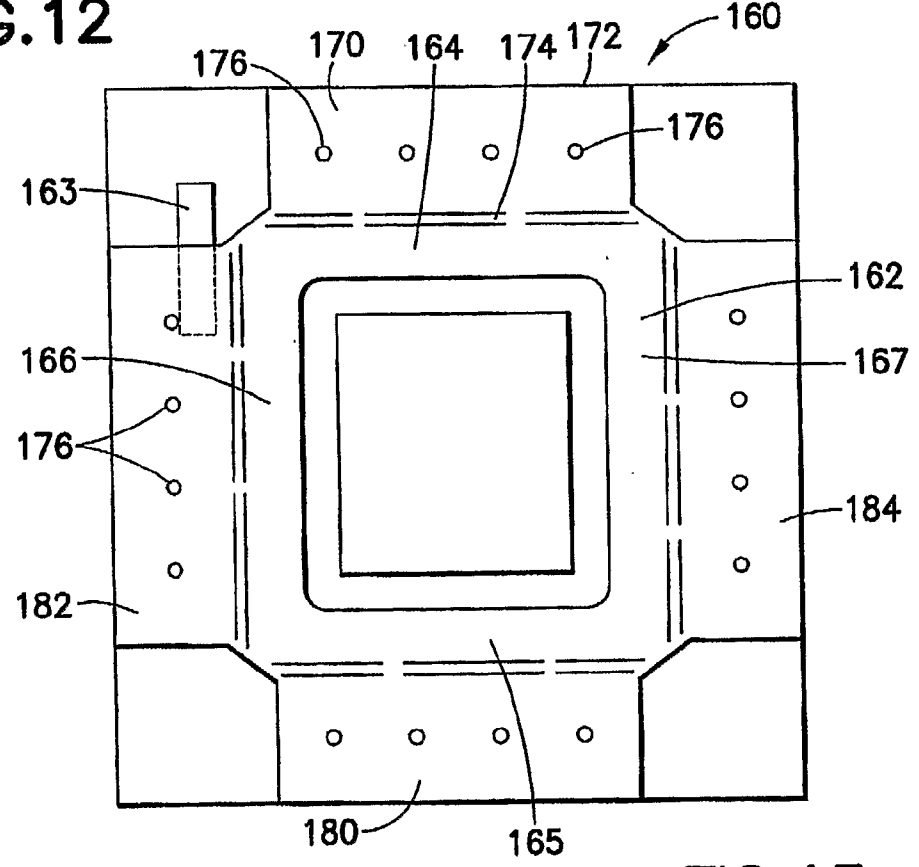

FIG. 13

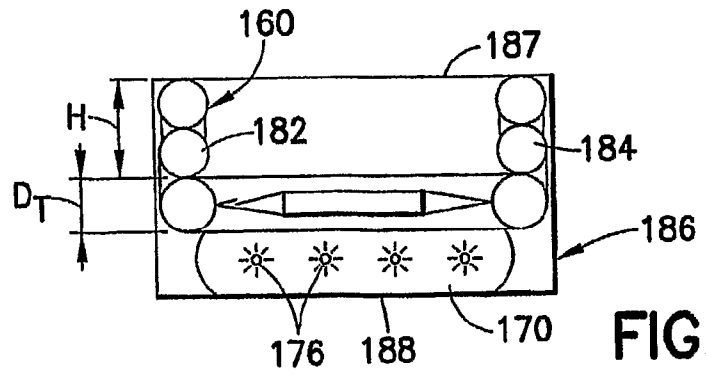
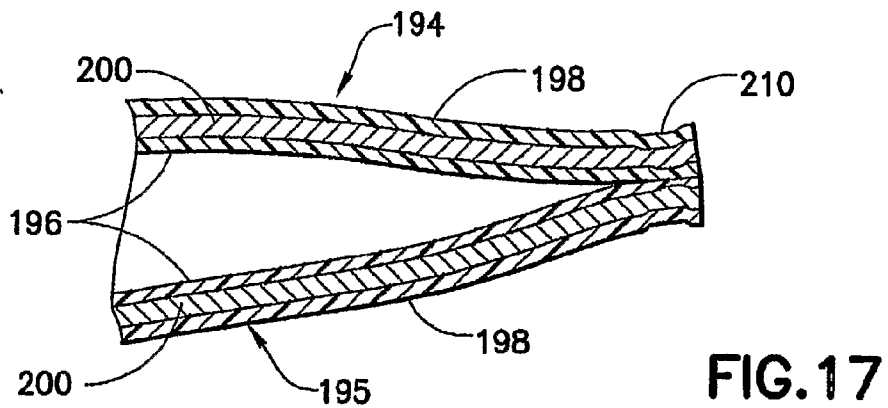
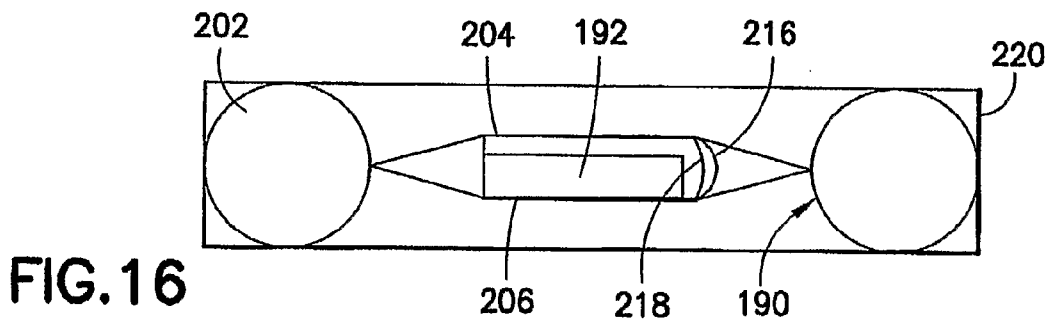
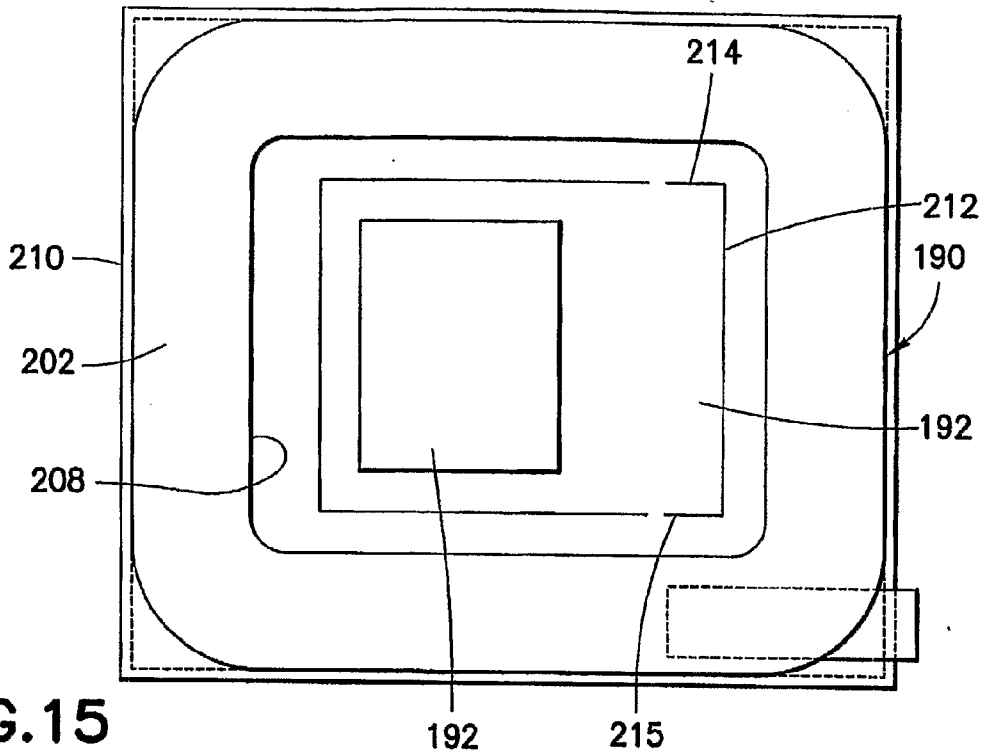

FIG. 14



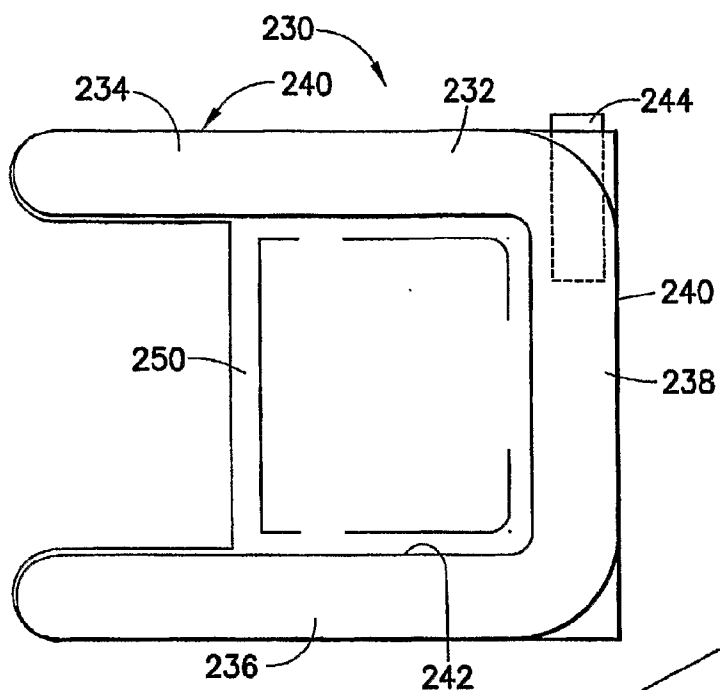

FIG. 18

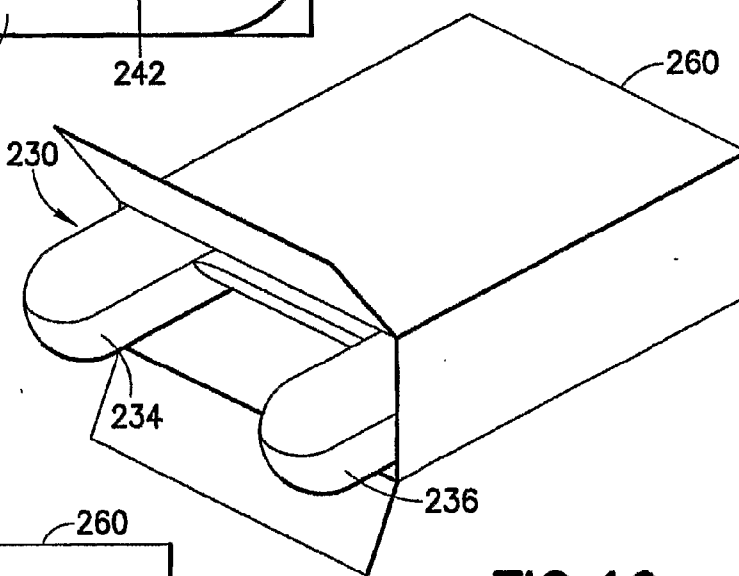

FIG. 19

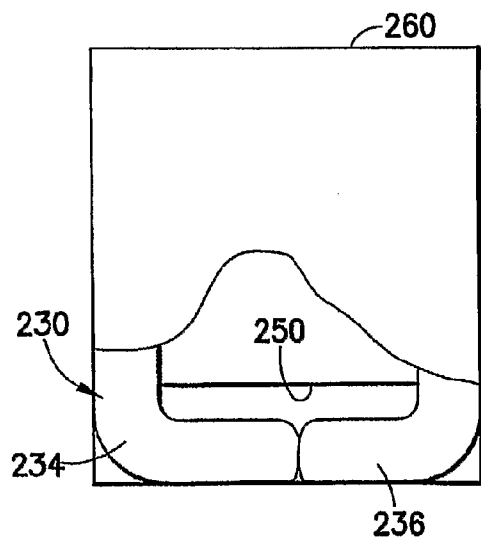

FIG. 20

PACKAGING SYSTEM WITH INFLATABLE CUSHION

PRIOR APPLICATION

[0001] This application claims priority to U.S. Provisional Application Ser. No. 60/541,596 filed Feb. 4, 2004.

FIELD OF INVENTION

[0002] The invention herein relates to a packaging system including an inflatable cushion that protects and stabilizes a product within a carton.

BACKGROUND OF INVENTION

[0003] Products are generally packaged in boxes for shipment, in order that the product may be protected and kept clean. In many instances, the product is not inherently fragile, but must be stabilized and cushioned within the carton, because movement within the carton could damage the product or permit the product to damage the integrity of the carton. In other instances, the product is fragile and must be protected from impact, deformation or other damaging forces.

[0004] In some instances, the product is stabilized and secured within a box by one or more preformed foam inserts. The foam insert(s) fill the space between the product and the inside walls of the carton, being shaped to conform to the product and maintain space between the product and the walls of the carton. There are many drawbacks to foam insert packaging systems. First, the foam inserts themselves are relatively expensive to fabricate. Second, the use of foam inserts has many additional costs that are primarily due to the bulk of the inserts. These include the space and consequent high shipping costs of delivering the foam inserts to the user, the amount of storage space required by the foam inserts at the user's facility, and the bulk of the foam inserts when disposed of. In fact, the foam inserts are sufficiently bulky that many users can only keep a few days' supply of foam inserts on their premises, wherein there is a risk of running out of inserts upon any disruption in the delivery process. Also, the foam inserts are not ecologically friendly, in that they are generally not made of recycled materials and are themselves difficult to collect for recycling.

[0005] An alternative system for surrounding and stabilizing products within shipping cartons is the use of cardboard spacers. The spacers are generally custom-designed for the product and carton, and often require folding and carefully positioning in order to accept the product and place the product within the shipping carton. The cardboard spacing systems are also relatively expensive and bulky, in addition to being somewhat difficult and labor-intensive to use.

[0006] Air cushioning systems have also been provided. These systems generally utilize a pillow of one or a plurality of inflated air compartments positioned above, below and beside a fragile product, i.e. air cushioning is provided on all sides of the product. When the product is not fragile, air filled bags have been used to fill voids in a box containing the product, so that the product is stabilized in the box.

[0007] All of these systems have certain drawbacks, and improvements on them would be welcome to those who package and ship products.

SUMMARY OF THE INVENTION

[0008] It is a principal object of the invention herein to provide improved packaging of products for shipment.

[0009] It is an additional object of the invention herein to provide an efficient alternative to foam inserts and/or cardboard spacers for protecting and stabilizing products in cartons.

[0010] It is also an object of the invention herein to reduce the shipping space, storage space and disposal space of protection systems utilized in shipping products in cartons.

[0011] It is a further object of the invention to provide improved air cushion packaging devices.

[0012] It is also an object of the invention to provide improved air cushion packaging devices that are adaptable to a wide range of products.

[0013] In carrying out the aspects of the invention herein, an air cushion for protecting products during shipment has a product placement area formed of two facing product support panels, which are portions of two substantially air impervious heat sealable thermoplastic sheets. An inflatable tube substantially surrounds the product placement area and is formed by tube walls that are respectively integral with the product support panels, namely, additional portions of the thermoplastic sheets that form the product support panels. An inside seam of the inflatable tube joins the thermoplastic sheets and the product support panels extend from the inside seam. An outside seam joins the two thermoplastic sheets opposed from the inside seam, thereby forming the inflatable tube. The outside seam may only have two segments if the two thermoplastic sheets are in the form of tube stock. An inflation valve is secured between the two thermoplastic sheets for admitting air to the inflatable tube and sealing air therein.

[0014] In other aspects of the invention, one of the product support panels has a slit creating an opening, whereby a product may be inserted in a product placement area between the two product support panels. Multiple slits may also be provided to accommodate a particular product.

[0015] The produce placement area may be rectangular and may be surrounded by the inflatable tube. The inflatable tube may be U-shaped, to expose an open end of the product support panels, and the distal ends of the U-shaped inflatable tube may fold across the open end of the product support panels to substantially surround the product placement area.

[0016] According to further aspects of the invention, the product support panels may be joined by a seam or seams to define a product placement area for a product of a particular shape. Also, the product support panels may be joined by seams to provide multiple product placement areas in the product support panels. Each such product placement area is provided with at least one opening in one of the product support panels.

[0017] In further aspects of the invention, two and preferably four additional stacking-height extension legs are provided adjacent to and extending from the inflation tube, the stacking-height extension legs being formed of further portions of the two thermoplastic sheets. The stacking-height extension legs are separated from the inflation tube by heat-fused seams, which are discontinuous to provide air

communication for inflating the stacking-height extension legs with the inflation tube. The stacking-height extension legs are foldable for deployment generally perpendicular to the product support panels, and are thereby adapted for positioning adjacent the walls of the carton in which the air cushion and a product supported thereby is inserted. Stacking-height extension legs having an inflated height greater than the diameter of the inflatable tube may be tufted by heat-fused spots, to maintain a width not substantially greater than the inflatable tube and thereby coordinate with the inflatable tube in fitting into a carton. The stacking-height extension legs are preferably provided in two diametrically opposed pairs, and one pair may be folded upwardly and one pair may be folded downwardly for nesting multiple air cushions with stacking-height extension legs in a carton.

[0018] According to a further aspect of the invention, an air cushion may be formed of thermoplastic sheets including a metallic layer for electro-magnetically shielding products supported therein. The product support panels are configured to fully surround and shield the product.

[0019] In also carrying out additional aspects of the invention herein, a shipping system is provided for a product having a general shape consisting of a top, bottom, peripheral side wall. The shipping system includes a rectangular carton sized and shaped to receive the product with clearance between the peripheral wall of the product and the walls of the carton. The shipping system also includes an air cushion including an inflatable tube substantially surrounding the peripheral wall of the product placed in a product placement area on product support panels substantially surrounded by the inflatable tube and sized and shaped for receiving one of the top and bottom of the product, and an inflation valve for admitting inflation air for inflating the tube to substantially surround the peripheral wall of the product with the product suspended and substantially surrounded by the inflatable tube. The tube is dimensioned so that upon inflation thereof, it surrounds the peripheral wall of the product and stabilizes the position of the product within the shipping carton.

[0020] The product may have a flange extending from the peripheral wall as an extension of the top of the product, and the air cushion is dimensioned to receive the flange on the inflatable tube.

[0021] Also according to aspects of the invention, the air cushion is fabricated of two sheets of polymer heat sealable air impervious material. The surface of the polymer sheet material contacting the product may have a higher coefficient of friction than the surface of the sheet contacting walls of the shipping carton. This permits the air cushion and product to be easily inserted into the shipping carton and enhances the ability of the air cushion to stabilize the air product within the shipping carton.

[0022] The foregoing and other objects and features of the invention herein will, in part, be apparent to those skilled in the art and will in part appear in the description of the preferred embodiments and the claims, taken together with the drawings.

BRIEF DESCRIPTION OF DRAWINGS

[0023] FIG. 1 is a perspective view of a product and an air cushion packaging system for the product according to the invention herein;

[0024] FIG. 2 is a sectional view of the product and air cushion packaging system of FIG. 1, taken in section through a closed shipping carton;

[0025] FIG. 3 is a top plan view of an air cushion according to the invention herein, used in the air cushion packaging system of FIG. 1, shown uninflated;

[0026] FIG. 4 is a sectional view of the air cushion of FIG. 3, shown inflated;

[0027] FIG. 5 is an enlarged segmental view of the air cushion of FIG. 3;

[0028] FIG. 6 is a top view of another air cushion according to the invention herein, used in packaging a product;

[0029] FIG. 7 is a sectional view, taken along the lines 7-7 of FIG. 6, of the air cushion of FIG. 6 used in packaging a product;

[0030] FIG. 8 is a top view of another air cushion according to the invention herein for use in an air cushion packaging system;

[0031] FIG. 9 is a top view of another air cushion according to the invention herein for use in an air cushion packaging system;

[0032] FIG. 10 is a top view of another air cushion for use in an air cushion packaging system according to the invention herein, with a product supported thereby;

[0033] FIG. 11 is a side, sectional view of the air cushion of FIG. 10, shown folded and positioned in a carton;

[0034] FIG. 12 is a side view of a plurality of the air cushion shown in FIG. 10, shown stacked in a carton;

[0035] FIG. 13 is a top view of another air cushion for use in an air cushion packaging system according to the invention herein;

[0036] FIG. 14 is a side, sectional view of the air cushion of FIG. 10 with a product supported thereby, shown folded and positioned in a carton;

[0037] FIG. 15 is a top view of another air cushion according to the invention herein for use in an air cushion packaging system;

[0038] FIG. 16 is a sectional view, taken along the lines 7-7 of FIG. 6, of the air cushion and packaging system of FIG. 6;

[0039] FIG. 17 is an enlarged, fragmentary, sectional view of the air cushion of FIG. 15.

[0040] FIG. 18 is a top view of another air cushion for use in an air cushion packaging system according to the invention herein;

[0041] FIG. 19 is a perspective view, of the air cushion of FIG. 8 shown inserted in a carton; and

[0042] FIG. 20 is a top view of the air cushion of FIG. 18 enclosed in the carton of FIG. 19.

[0043] The same reference numerals refer to the same elements throughout the various figures.

DETAILED DESCRIPTION OF PREFERRED EMBODIMENTS

[0044] With reference to FIGS. 1-5, a product 1 and a packaging system 10 for the product 1 according to the

invention herein are illustrated. The product 1 is an imaging film cassette having a tray 2 with a peripheral side wall 3, a bottom 4 and a top 5. The tray has a peripheral flange 6 extending outwardly from the side wall 3, and the top 5 is secured to the peripheral flange. The tray 2 is generally rectangular, wherein the peripheral side wall 3 is formed in four panels that are joined at rounded corners, such as corner 7.

[0045] The packaging system 10 includes a carton 12 and an air cushion 14. The carton 12 is fabricated of corrugated carton stock and has a bottom 16, peripheral side walls 18 and end walls 20, and cover flaps 22 and 24, which fold flat and are taped or glued to assemble the carton 12 in a rectangular closed configuration. As shown in FIG. 1, the carton 12 may be provided as a flattened sheet with scored fold lines and the product is placed on the bottom panel prior to folding the carton into the closed configuration shown in FIG. 2.

[0046] Prior to the invention herein, the product 1 was held in position by a foam carton insert consisting of a foam periphery, and a foam bottom panel. The tray 2 fitted in the foam insert with the flange supported on the peripheral foam wall which held the top of the tray against the underside of the cover flaps 22 and 24, when they were folded shut.

[0047] The air cushion 14 is shown in FIGS. 3-5, and is fabricated of two substantially air impervious sheets 26 and 28 that are heat fused together at outside seam 30 and inside seam 32 to define a peripheral inflatable tube 34. An air valve 36 extends through seam 30 for delivering inflation air to the inflatable tube 34. The air cushion has two facing product support panels 38 and 39 that form a generally rectangular product placement area 37, surrounded by the inflatable tube 34. The substantially air impervious sheets 26 and 28 are a thermoplastic heat sealable polymer so that the seams 30 and 32 may be formed by heating the superimposed sheets. The sheets may be a mono-layer of polyethylene, or when a longer air retention is required, may be laminated or coextruded plies of polyethylene and nylon, EVOH or other highly air impervious material. [text missing or illegible when filed] 38, 39 and the inflatable tube 34 are integrally formed of the tw [text missing or illegible when filed]

[0048] With reference to FIGS. [text missing or illegible when filed] generally rectangular, with rounded corners, sized so that [text missing or illegible when filed]ly surrounds the peripheral side wall 3 of the product 1. With particular reference to FIG. 2, the bottom 4 of the product 1 is received on the product support panel 38 and the flange 6 of the product is received between the inflatable tube 34 and the top of the carton 12, wherein the bottom 4 of the product is suspended above the bottom 16 of the carton 12. Thus, the product 1 is cushioned and stabilized within the carton 12, and is in part protected from damage by an air suspension effect of the air cushion 14.

[0049] The packaging system 10 passes all drop and shock tests that are required of the foam packaging insert it replaces. It saves substantial amounts of shipping and storage room by the user. For instance, one pallet of air cushions 14 will provide for shipping the same number of products as seventy-five pallets of foam inserts. The recipient of the packages also benefits, in that the air cushion may be punctured or otherwise deflated to return it to its compact form for disposal. Disposal may include recycling.

[0050] With reference to FIGS. 6 and 7, another air cushion 50 is shown. The air cushion 50 is similar to the air cushion 14, being fabricated of two sheets 26, 28 of thermoplastic heat-sealable material sealed together at seams 30, 32 to define an inflatable tube 34. The two thermal plastic sheets 26 and 28 integrally form two product support panels 38, 39 extending from the inside seam 30. An air valve 36 is positioned in outside seam 32, for inflating the tube 34.

[0051] The air cushion 50 is characterized by a slit 52 in the support panel 38. The slit 52 creates an opening 54, which provides for inserting a product 56 into a product placement area 58 between the product support panels 38 and 39.

[0052] The air cushion 50 is used in conjunction with a carton 60, the side walls 61, 62 and end walls 63, 64 of which are seen in FIG. 6 and the top 66 and bottom 68 of which are best seen in FIG. 7. The inflatable tube 34 is sized to fit snugly against the side walls 61, 62 and end walls 63, 64, and also spans the distance between the top and bottom walls 66, 68. The air cushion 50 and the carton 60 are preferably cooperatively sized so that the product support panels 38, 39 are under tension across the interior of the inflatable tube 34, wherein they hold the product 56 substantially in position and also resist deflection, somewhat in the manner of a trampoline or flexible diaphragm, so that the product 56 is cushioned against shocks and does not impact against the walls, top or bottom of the carton, or if the product 56 does so impact, that the impact is light and non-damaging to the product.

[0053] FIG. 8 illustrates another air cushion 70, which is also similar to the air cushions 14, 50 and 60 being formed of two thermoplastic sheets heat sealed at seams 30, 32 to define an inflatable tube 34 with product support panels 38, 39 extending from the inside seam 32. The two thermoplastic sheets are tube stock in flattened condition, whereby the outside seam 30 is provided in two sections 30a and 30b, and this form of two sheets is applicable to other embodiments as well. An inflation valve 36 is provided in seam 30.

[0054] In air cushion 70, the product support panels 38, 39 are heat fused together along seams 72 and 74, to divide the product support panels into four product placement areas 76-79. Each of the product placement areas 76-79 is respectively provided with a slit 80-83 in the product support panel 38, wherein products may be inserted into each of the product placement areas 76-79. The air cushion 70 is inserted in a carton 60 for shipping, as described above with respect to air cushion 50. This configuration is useful for packaging a plurality of small, fragile products.

[0055] In FIG. 9, air cushion 90 is also similar to air cushions 14, 50, 60 and 70 in having an inflatable tube 34 and product support panels 38 and 39 extending from the inside seam 32 forming the inflatable tube 34. The air cushion 90 is characterized by having the product support panels 38 and 39 heat sealed together along seams 91, 93 and 95 to provide product placement areas 92, 94 and 96 that are each specifically shaped for a particular product. Slits 97, 98 and 99 are formed in the product panel 38, for inserting products into the product placement areas 92, 94 and 96, respectively. This configuration of air cushion 90 is also well adapted to shipping a plurality of small products, and especially a set of small products of different shapes in a single carton with the products held in position and cushioned against impact.

[0056] With reference to FIGS. 10 and 11, an air cushion 100 is shown for use with products requiring special impact protection, products having a relatively large physical dimension, or heavier products that tend toward greater movement upon impact. The air cushion 100 is also formed of two sheets of thermoplastic material heat sealed together along seams to achieve the desired configuration and function.

[0057] The air cushion 100 has a generally rectangular inflation tube 102 with opposed side portions 104, 105 and opposed end portions 106, 107. As with the other air cushions disclosed above, the comers between the side portions and end portions are rounded for smooth transmission and the avoidance of stress points on the seams.

[0058] The inflation tube 102 is defined by inside seam 110, and product support panels 112 and 113 extend from the inside seam 110. A slit 114 provides an opening for inserting a product 116 into a product placement area 118 between the product support panels 112 and 113.

[0059] Adjacent side 104 of the inflation tube 102, a first stacking height extension leg 120 is formed, by seam 122 and by the portion 124 of outer seam 125 defining the inflatable tube 102. The seam portion 124 has discontinuities to form openings 126, permitting air communication between the stacking height extension leg 120 and the inflatable tube 102. Thus, the inflation valve 128 for the air cushion 100 may be placed in seam 122, for inflating the stacking height extension leg 120, the inflatable tube 102, and additional stacking height extension legs, as further described below.

[0060] A second stacking height extension leg 130 is formed extending from side 105 of inflatable tube 102, opposite the stacking height extension leg 120, stacking height extension leg 130 is defined by seam 132 and by portion 134 of the outside seam 125. The seam 134 is discontinuous to provide openings 136 for inflating the stacking height extension leg 130.

[0061] Stacking height extension legs 140 and 142 are similarly respectively formed adjacent end portions 105 and 106 of the inflation tube 102. In the air cushion 100 illustrated, flaps of the two thermoplastic sheets forming the air cushion remain at the comers, such as flap 144. If desired, these may be cut away, but they do not interfere with the operation of the air cushion 100.

[0062] With reference to FIG. 11, the air cushion 100 is shown supporting the product 116 within a carton 146. The stacking height extension legs 140 and 142 are folded upwardly along the side walls 147 of the carton 146, to further separate the product 116 from the top 148 of the carton. Stacking height extension legs 120 and 130 are folded downwardly with respect to the inflatable tube 102, and provide further separation of the product from the bottom 149 of the carton 146. It will be appreciated that in the sectional view of FIG. 11, the stacking height extension leg 130 is not visible, but it assumes the same position as the stacking height extension leg 120.

[0063] To promote a vertical stacked relationship of the inflation tube 102 and the stacking height extension legs, it is preferred that the diameter DL of the inflated stacking height extension legs be approximately the same as the diameter DT of the inflation tube. Additionally, the seams

joining the inflation tube and an adjacent stacking height extension leg, such as seam 143, have a width W which is approximately the same as the diameters of the stacking height extension legs and inflatable tube 102. Thus, the width of the seam positions to stacking height extension legs above or below the inflatable tube, i.e. in vertically stacked relationship.

[0064] As shown in FIG. 12, a plurality of air cushions 100, 100a, etc. may be stacked in a single carton in a nesting arrangement, where the downwardly folded stacking height extension legs of one air cushion 100 are received on the inflation tube of the next lower air cushion 100a, and the upwardly folded stacking height extension legs of the lower air cushion 100a support the inflatable tube of the air cushion 100 positioned above it. This provides for packaging a plurality of protected products in one carton.

[0065] In some instances, it is desirable that the stacking height extension legs have a greater dimension than provided in air cushion 100, where the dimension is approximately equal to the diameter of the inflatable tube 102. However, it is also preferable to provide the stacking height extension leg having a thickness of approximately the same dimension as the diameter of the inflatable tube 102. An air cushion 160 shown in FIGS. 13 and 14 satisfies these objectives.

[0066] The air cushion 160 is also fabricated of two thermoplastic sheets heat sealed together along seams that provide the structure and configuration required. The air cushion 160 has an inflatable tube 162, with side portions 164, 165 and end portions 166, 167. A first stacking height extension leg 170 is formed by seam 172 adjacent side 164, and seam 174 between the stacking height extension leg 170 and inflatable tube 162 is discontinuous for air communication. An inflation valve 163 is provided.

[0067] The stacking height extension leg 170 has a height H approximately twice as great as the diameter Dt of the inflatable tube 162. In order that the stacking height extension leg 170 does not assume a greater diameter, heat-fused spot seams 176 are provided joining the two thermoplastic sheets approximately midway across the stacking height extension leg 170. This causes the stacking height extension leg 170 to assume a tufted configuration when inflated, as best seen in FIG. 14, and limits the thickness of the stacking height extension leg a dimension approximately equal to the diameter DT of the inflatable tube 162. Stacking height extension legs 180 is provided adjacent side 165 of inflatable tube 162 opposite the stacking height extension leg 170, and an additional to tufted stacking height extension legs 182 and 184 are formed adjacent the ends 166, 167 of the inflatable tube 162.

[0068] As best seen in FIG. 14, the tufted stacking height extension legs provide a greater separation of the product panels and product held therein from the top 187 and bottom 188 of a carton 186, without increasing the thickness of the stacking height extension legs.

[0069] FIGS. 15-17 illustrate an air cushion 190 particularly adapted for packaging and shipment of sensitive electronic devices that can be damaged by electromagnetic radiation as well as by impact. An example of such a device is a computer mother board, which is the product 192 shown in association with the air cushion 190.

[0070] With initial reference to FIG. 17, the thermoplastic heat sealable sheets 194, 195 used to fabricate the air cushion 190 are a lamination of a thermoplastic heat sealable inner layer 196 and a nylon, polyester or other polymer outer layer 198, with a metallic layer 200 therebetween. The metallic layer 200 may be aluminum particles coated onto one of the inner or outer layers, may be another metal or a conductive material deposited on one of the films, or may be a foil laminated between layers 196 and 198. Thus, when the air cushion 190 is fabricated by forming heat sealed seams, such as seam 210 the inner thermoplastic heat sealable layers 196 are joined together.

[0071] With further reference to FIG. 15, the air cushion 190 has an inflatable tube 202, which is generally rectangular in the embodiment shown, and two product support panels 204, 206 extending from and supported by the inflatable tube 202. The inside seam 208 of the inflatable tube 202 defines the outer periphery of the product support panels 204 and 206; however, the product support panels are further joined together at product perimeter seam 210 which is dimensioned to closely receive the mother board product 192.

[0072] A slit 212 is formed through both product support panels 205 and 206, and the slit is U-shaped having end legs 214 and 215 aligned with the product support seam 210. This provides end flap 216 of the product support panel 204 and end flap 218 of the product support panel 206 and the end flaps 216 and 218 are overfolded as shown in FIG. 16 and secured in that position by tape, stapling, or the like so that the mother board 192 is fully encapsulated in foil layers of the product support panels. Thus, the mother board 192 is encapsulated in a foil layer that acts as a faraday cage, that protects it from electromagnetic radiation during storage and shipment.

[0073] FIG. 16 also shows how the air cushion 190 is used in conjunction with a shipping carton 220, wherein the mother board is centrally suspended supported in the carton and protected from impact, as well as from radiation.

[0074] FIGS. 18-20 illustrate another air cushion 230, characterized by a U-shaped inflation tube 232. The U-shaped inflation tube 232 has side legs 234 and 236, and an end leg 238. It is formed from two thermoplastic sheets which are heat sealed together along an outside seam 240 and in inside seam 242 to form the inflation tube. An inflation valve 244 is provided at the end of side leg 234 or at another convenient location.

[0075] Two product support panels extend from the side legs 234, 236 and the end leg 238, and define an entry opening at 250 for inserting a product. If desired, the product support panels can be provided with product support seams positioned to closely accommodate the dimensions of the product, such as a picture frame. One advantage of the air cushion 230 is that the entry to the product placement area between the two product support sheets is the full width between the legs 234 and 236, wherein a relatively wide product may be easily inserted.

[0076] With reference to FIG. 19, once the product has been inserted, the air cushion 230 and the product therein may be inserted into a carton 260 through an open end thereof. The end portions of the legs 234, 236 are then be folded inwardly to be contained within the carton when its

end flaps are closed, and the two end portions provide the cushioning protection for the product at the open end of the product support panels, as illustrated in FIG. 20.

[0077] The air cushions described above are preferably made of heat-fusible polymers, such as mono-layer of polyethylene, or polyethylene laminated with other and more highly air impervious layers if long air retention time is desired, all as is well known in the art. In addition, the surface of the air cushion which is received against a product may be provided with a different coefficient of friction, such as by selection of the film or embossing or matte finishing the film, to assist in holding the product in place on the air cushion. Further, the surface of the air cushion presented to the interior of the carton may be provided with a lower coefficient of friction, so that the air cushion and product slide easily into the carton. All air cushions described above share the benefits of being shipped compactly to the user and stored in a small space by the user. They are also easily reduced in bulk for disposal, and may be recycled. The inflatable tubes of the air cushions typically have a width and length of about 15"-20" and a diameter of about 1"-3" when inflated, but both larger and smaller dimensions are within the scope of the invention.

[0078] It will be appreciated that the inflatable tubes may continuously or substantially surround the product, and that the inflatable take may be provided in segments or connected chambers, as desired. Also, the configuration of slits, openings and seams utilized to receive a product on the product on the product support panels may be varied to accommodate a variety of products.

[0079] The foregoing packaging systems admirably achieve the objects of the invention herein. However, it will be understood that they are illustrative of the invention, and that various changes may be made without departing from the spirit and scope of the invention, which is limited only by the following claims.

1. An air cushion for protecting products during shipment, the air cushion fabricated of two sheets of heat sealable thermoplastic material secured together by heat sealed seams, and comprising:

- a. an inflatable tube having a closed or substantially closed configuration, the inflatable tube in part defined by an inside seam;
- b. two facing product support panels extending from the inside seam of the inflatable tube; and
- c. the product support panels providing a product placement area for receiving and holding a product suspended on the product support panels and substantially surrounded by the inflatable tube.

2. An air cushion for protecting products during shipment as defined in claim 1, wherein the inflatable tube has a continuous, closed configuration.

3. An air cushion for protecting products during shipment as defined in claim 2, wherein the inflatable tube has a generally rectangular configuration.

4. An air cushion for protecting products during shipment as defined in claim 1, the air cushion having a U-shaped configuration wherein the distal ends of the legs of the U-shaped inflatable tube are foldable to substantially surround a product in the product placement area.

5. An air cushion for protecting products during shipment as defined in claim 1, wherein one of the product support panels is slit to define an opening, and the product placement area is defined between the product support panels and accessible for inserting and removing a product through the opening.

6. An air cushion for protecting products during shipment as defined in claim 5, wherein the product support panels are joined by the seams to provide multiple product placement areas, and at least one of the product support panels in some of the product placement areas being provided with a slit defining an opening for inserting and removing a product.

7. An air cushion for protecting products during shipment as defined in claim 6, wherein the product support panels are joined by one or more seams to define one or more product placement areas closely accommodating the shapes of one or more particular products.

8. An air cushion for protecting products during shipment as defined in claim 1, and further comprising the plurality of stacking height extension legs extending from the inflatable tube at an outside seam thereof and foldable to overlie or underlie the inflatable tube.

9. An air cushion for protecting products during shipment as defined in claim 8, wherein the stacking height extension legs are sized to provide a thickness of approximately the same dimension as the diameter of the inflatable tube.

10. An air cushion for protecting products during shipment as defined in claim 9, wherein the stacking height extension legs have a stacking height greater than the diameter of the inflatable tube, and are provided with medial discontinuous seams limiting the thickness of the stacking height extension legs to approximately the same dimension as the diameter of the inflation tube.

11. An air cushion for protecting products during shipment as defined in claim 1, wherein the sheets of heat sealable thermoplastic material incorporate a conductive layer, whereby a product received in a product placement area between the product support panels is shielded from electromagnetic fields.

12. An air cushion for protecting products during shipment as defined in claim 1 and further comprising a carton for receiving the air cushion and product, the air cushion and carton sized and dimensioned such that the air cushion is supported against the sides, top and bottom of the carton and the product is suspended and substantially surrounded by the inflatable tube within the carton.

13. A packaging system as defined in claim 11 wherein the inflatable cushion is made of two sheets of substantially air impervious material, the surface of one sheet having a higher co-efficient of friction than the surface of the other sheet so that the surface with the higher co-efficient of friction grips the product to hold the air cushion in position and the sheet with the lower co-efficient of friction facilitates sliding the product and air cushion into the carton.

14. A packaging system for a product having a peripheral wall, a top and a bottom, the packaging system comprising:

- a. a generally rectangular carton dimensioned to receive the product with clearance around the peripheral wall of the product;
- b. an air cushion having inflatable tube sized for contacting and engaging the walls of the carton when inflated and placed therein, a valve for inflating the inflatable tube; and
- c. the air cushion having a product placement area defined by two facing product support panels integral with and extending from the inflatable tube,

wherein the product support panels are adapted to support a product in the product placement area and provide air cushioned separation between the product and at least some walls of the carton, thereby stabilizing and cushioning the product therein.

15. A packaging system as defined in claim 14 wherein the inflatable tube fully surrounds a peripheral sidewall of the product.

16. A packaging system as defined in claim 15 wherein at least one of the product support panels defines an opening for inserting a product into the product placement area which is between the product support panels.

17. A packaging system as defined in claim 14 wherein the inflatable cushion is made of two sheets of substantially air impervious material, the surface of one sheet having a higher co-efficient of friction than the surface of the other sheet so that the surface with the higher co-efficient of friction grips the product to hold the air cushion in position and the sheet with the lower co-efficient of friction facilitates sliding the product and air cushion into the carton.

* * * * *