

(19) World Intellectual Property Organization
International Bureau



(43) International Publication Date
18 December 2003 (18.12.2003)

PCT

(10) International Publication Number
WO 03/104832 A1

- (51) International Patent Classification⁷: **G01R 33/561**
- (21) International Application Number: PCT/IB03/02162
- (22) International Filing Date: 21 May 2003 (21.05.2003)
- (25) Filing Language: English
- (26) Publication Language: English
- (30) Priority Data:
02077260.4 10 June 2002 (10.06.2002) EP
- (71) Applicant (*for all designated States except US*): **KONINKLIJKE PHILIPS ELECTRONICS N.V.** [NL/NL]; Groenewoudseweg 1, NL-5621 BA Eindhoven (NL).
- (72) Inventor; and
- (75) Inventor/Applicant (*for US only*): **KOUWENHOVEN, Marc** [NL/NL]; c/o Prof. Holstlaan 6, NL-5656 AA Eindhoven (NL).
- (74) Agent: **COHEN, Julius, S.**; Internationaal Octrooibureau B.V., Prof. Holstlaan 6, NL-5656 AA Eindhoven (NL).
- (81) Designated States (*national*): AE, AG, AL, AM, AT, AU, AZ, BA, BB, BG, BR, BY, BZ, CA, CH, CN, CO, CR, CU, CZ, DE, DK, DM, DZ, EC, EE, ES, FI, GB, GD, GE, GH, GM, HR, HU, ID, IL, IN, IS, JP, KE, KG, KP, KR, KZ, LC, LK, LR, LS, LT, LU, LV, MA, MD, MG, MK, MN, MW, MX, MZ, NI, NO, NZ, OM, PH, PL, PT, RO, RU, SC, SD, SE, SG, SK, SL, TJ, TM, TN, TR, TT, TZ, UA, UG, US, UZ, VC, VN, YU, ZA, ZM, ZW.
- (84) Designated States (*regional*): ARIPO patent (GH, GM, KE, LS, MW, MZ, SD, SL, SZ, TZ, UG, ZM, ZW), Eurasian patent (AM, AZ, BY, KG, KZ, MD, RU, TJ, TM), European patent (AT, BE, BG, CH, CY, CZ, DE, DK, EE, ES, FI, FR, GB, GR, HU, IE, IT, LU, MC, NL, PT, RO, SE, SI, SK, TR), OAPI patent (BF, BJ, CF, CG, CI, CM, GA, GN, GQ, GW, ML, MR, NE, SN, TD, TG).
- Published:**
- *with international search report*
 - *before the expiration of the time limit for amending the claims and to be republished in the event of receipt of amendments*
- For two-letter codes and other abbreviations, refer to the "Guidance Notes on Codes and Abbreviations" appearing at the beginning of each regular issue of the PCT Gazette.*



WO 03/104832 A1

(54) Title: MAGNETIC RESONANCE IMAGING METHOD

(57) Abstract: A magnetic resonance imaging method for forming an image of an object from a plurality of signals acquired by an array of multiple receiver antennae, wherein spins are excited in a part of the object. Slices (22) are selected with a predetermined Field-of-View for scanning the object and are rotated uniformly over a predetermined angle. MR signals are measured along a predetermined trajectory containing a plurality of lines said slices in k-space by application of a read gradient and other gradients. Further the slices (24) are shifted in lengthwise direction obtaining a staggered arrangement such that the beginning and the end of each of said slices are at least approximately within the area covered by the slices before rotation.

MAGNETIC RESONANCE IMAGING METHOD

The invention relates to a magnetic resonance (MR) method for the imaging of an object arranged in a steady magnetic field, whereas the following steps being repeatedly executed according to said method:

excitation of spins in a part of the object,

5 slices are selected within the Field-of-View (FOV) of the object to be scanned,

said selected slices are scanned in an oblique relationship with respect to the cartesian coordinate system of a rectangular area of interest, and

measurement of MR signals along a predetermined trajectory containing a plurality of lines in said slices in k-space by application of a read gradient and other gradients.

10 The invention also relates to an MR device for carrying out such a method.

It is generally known in multiple slice imaging techniques that parallel slices are imaged in such a manner that if parallel slices are rotated they are kept at the same position to each other in order to obtain a proper image of the object. However, backfolding artifacts cannot always be prevented as parts outside of the rectangular FOV will be covered
15 also by the scan.

In magnetic resonance imaging there is further a general tendency to obtain acceptable images within shorter periods of time. For this reason the sensitivity encoding method called "SENSE" has recently been developed by the Institute of Biomedical Engineering and Medical Informations, University and ETH Zürich, Switzerland. The
20 SENSE method is based on an algorithm which acts directly on the image as detected by the coils of the magnetic resonance apparatus and which subsequent encoding steps can be skipped and hence an acceleration of the signal acquisition for imaging by a factor of about two to three can be obtained. Crucial for the SENSE method is the knowledge of the sensitivity of the coils which are arranged in so called sensitivity maps. In order to accelerate
25 this method there are proposals to use raw sensitivity maps which can be obtained through division by either the "sum-of-squares" of the single coil references or by an optional body coil reference (see e.g. K. Pruessmann et. al. in Proc. ISMRM, 1998, abstracts pp. 579, 799, 803 and 2087). In fact the SENSE method allows for a decrease in scan time by deliberately undersampling k-space, i.e. deliberately selecting a scanning Field-of-View (FOV) that is

smaller than the object to be acquired. From this undersampling fold-over artifacts are obtained which can be resolved or unfolded by the use of the knowledge of a set of distinct coils having different coil sensitivity patterns. The undersampling can be in either one of both phase-encoding directions.

5 If the object exceeds the FOV to be reconstructed (in the phase encoding SENSE direction) residual backfolding will occur with the SENSE method which will be apparent somewhere in the middle of the image.

 It is an object of the present invention to prevent forming of backfolding artifacts both with and without the SENSE technique as mentioned above.

10 This object has been solved by the method with the features as described in Claim 1.

 The method according to the present invention has the important advantage, that in a very easy manner the forming of residual backfolding artifacts is prevented.

15 These and other advantages of the invention are disclosed in the dependent claims and in the following description in which an exemplified embodiment of the invention is described with respect to the accompanying drawings. It shows:

20 Fig. 1 an MR apparatus for carrying out the method, and
 Fig. 2 three panes to explain the inventive method.

 In Figure 1 a magnetic resonance apparatus 1 is diagrammatically shown. The apparatus comprises a set of main magnetic coils 2 for generating a stationary homogeneous
25 main magnetic field and several sets of gradient coils 3, 4 and 5 for superimposing on to the main magnetic field additional magnetic fields with controllable strength and having a gradient in a selected direction. Conventionally, the direction of the main magnetic field is labeled the z direction, the two directions perpendicular thereto are the x and y directions. The gradient coils are energized via a power supply 11. The apparatus further comprises
30 excitation means 6 in the form of a so-called body coil for emitting radio-frequency pulses (RF-pulses) to an object or body 7, the excitation means 6 being coupled to modulating means 8 for generating and modulating of the RF-pulses. Also provided are means for receiving the MR-signals, these means can be identical to the excitation means 6 or be separate, as with the present invention, in the form of an array of receiver coils 16. A body

coil is a coil surrounding a (part of a) body and has generally a very homogeneous sensitivity distribution, whereas a receiver coil is a coil used close to one side of a (part of a) body. A receiver coil has generally a limited field of view, a high sensitivity but an inhomogeneous spatial sensitivity distribution. A send-receive switch 9 is arranged to separate the received signals from the excitation pulses. The received magnetic resonance signals are input to receiving and demodulating means 10. The excitation means 6 and modulating means 8 and the power supply 11 for the gradient coils 3, 4 and 5 are steered by a control system 12 to generate a predetermined sequence of RF-pulses and gradient field pulses. The demodulation means is coupled to data processing means 14, for example a computer, for transformation of the received signals into an image that can be made visible, for example on a visual display unit 15.

If the magnetic resonance apparatus 1 is put into operation with an object or body 7 placed in the magnetic field, a small excess of magnetic dipole moments (nuclear or electron spins) in the body will be aligned in the direction of the magnetic field. In equilibrium, this causes a net magnetization M_0 in the material of the body 7, directed in parallel with the magnetic field. In the apparatus 1 the macroscopic magnetization M_0 is manipulated by radiating to the body RF-pulses having a frequency equal to the Larmor frequency of the dipole moments, thereby bringing the dipole moments in an excited state and re-orienting the magnetization M_0 . By applying the proper RF-pulses, a rotation of the macroscopic magnetization is obtained, the angle of rotation is called the flip-angle. The introduction of variations in the magnetic field by applying gradient magnetic fields influences the behavior of the magnetization locally. After the application of RF-pulses, the changed magnetization will tend to return to a state of thermal equilibrium in the magnetic field, emitting radiation in the process. A well chosen sequence of RF-pulses and gradient field pulses causes the radiation to be emitted as (decaying) magnetic resonance signals which provide spatial information about the density and/or relaxation times of a certain type of nuclei, for example hydrogen nuclei, and the substance in which they occur. By analysis of the emitted signals, picked up by the coil 6 or with the receiver coil array 16 – and by presentation of it in the form of images, information about the internal structure of the object or body 7 is accessible. The decaying magnetic resonance signal directly after the excitation is called FID (Free Induction Decay). By proper application of the gradients and/or application of additional excitation (RF) pulses also an echo of the FID may be produced and used to derive image information. For a more detailed description of magnetic resonance imaging (MRI) and MRI-devices reference is made to the extensive literature on this subject,

for example to the book "Magnetic Resonance Imaging", by M.T. Vlaardingerbroek, Springer Verlag, 1996.

In Figure 2a an object 20 to be scanned (e.g. the heart) which is surrounded by a rectangular area of interest 21 (e.g. part of the human body) is shown which will be scanned with the above mentioned MR apparatus 1 in parallel slices 22 which are set by the user. Imaging occurs in a rectangular area, the length thereof is determined by the Field-of-View (FOV) and the width thereof is determined by the so-called Rectangular Field-of-View (RFOV), which can be freely defined by the operator of the MR machine. The RFOV direction is also the foldover direction (and can be also a SENSE encoding direction) In our example in Figure 2. As can be seen the longitudinal axis 23 of the object to be scanned is at an angle α to the direction z of the RFOV or to the z axis of the cartesian coordinate system of the rectangular area of interest 21, i.e. the FOV. Thus, according to Figure 2b the slices 22 are rotated over an angle α in order to obtain an improved imaging of the object 20. However, since the slices 22 are normally kept in an exact parallel relationship, part of the slices 22 fall out of the area as covered by the original RFOV. When the angle α is for example 30° and the thickness B of the slices 22 is 1 cm with a gap of 0 cm between the slices 22 than the area 25 depicted in dashed lines will cover 5 cm in vertical direction y. Now, according to Fig. 2c the rotated slices 22 are shifted in their longitudinal direction over a distance $B * \sin \alpha$ so that the start positions and the end positions of the slices 22 coincide approximately with the area of the RFOV. Thus, the slices 22 do not fall outside of the original RFOV from the slices before rotation (Fig. 2a) and any tissue outside of that area will not be covered any more, thus preventing any backfolding artifacts. Especially for fast sampling methods like SENSE this is crucial as residual backfolding artifacts would lead to serious artifacts which cannot be suppressed easily. Additionally to the shift of the slices 22 the lines to be scanned within the slices 24 can have a uniform offset at a direction perpendicular to the direction of the respective slice 22. Additionally or alternatively the original RFOV may be diminished which leads to faster scanning.

Instead of rotating the slices 22 also an oblique direction with respect to the rectangular orientation of the original slices can be selected for scanning the slices 22.

CLAIMS:

1. A magnetic resonance imaging method for forming an image of an object from a plurality of signals acquired by an array of multiple receiver antennae, wherein
- spins are excited in a part of the object,
 - slices with a predetermined Field-of-View are selected for scanning the object,
 - 5 - said selected slices are scanned in an oblique relationship with respect to the cartesian coordinate system of said Field-of-View,
 - MR signals are measured along a predetermined trajectory containing a plurality of lines in said slices in k-space by application of a read gradient and other gradients, characterized in that said slices are positioned in lengthwise direction for
 - 10 obtaining a staggered arrangement of said slices such that the beginning and the end positions of each of said slices are at least approximately within said Field-of-View.
2. A method as claimed in claim 1, characterized in that the selected slices are rotated uniformly over a predetermined angle in order to obtain said oblique relationship.
- 15
3. A method as claimed in claim 1 or 2, characterized in that the beginning position of any subsequent slice with respect to the prior one is shifted over the slice thickness multiplied with the sinus of the rotating angle.
- 20
4. A method as claimed in claim 3, characterized in that lines to be scanned within each of said slices have a uniform offset along a line perpendicular to the direction of the slice.
5. A magnetic resonance imaging apparatus for obtaining an MR image from a plurality of signals comprising:
- 25
- means for excitation of spins in a part of the object,
 - means for selection of slices with a predetermined Field-of-View for scanning the object,

- means for selecting said slices in an oblique relationship with respect to the cartesian coordinate system of said Field-of-View,
- means for measuring MR signals along a predetermined trajectory containing a plurality of lines in said slices in k-space by application of a read gradient and other gradients,
- means for setting the scanning direction of said slices in such a manner that tissue outside the area of interest is not covered, and
- means for positioning said slices in lengthwise direction obtaining a staggered arrangement of said slices such that the beginning and the end positions of each of said slices are at least approximately within the area of interest.

6. A magnetic resonance imaging apparatus as claimed in claim 5, further comprising means for rotating the selected slices uniformly over a predetermined angle in order to obtain said oblique relationship.

7. A computer program product stored on a computer usable medium for forming an image by means of the magnetic resonance method, comprising a computer readable program means for causing the computer to control the execution of:

- excitation of spins in a part of the object,
- selection of slices with a predetermined Field-of-View,
- selecting said slices to be scanned in an oblique relationship with respect to the cartesian coordinate system of a rectangular area of interest,
- measuring MR signals along a predetermined trajectory containing a plurality of lines in said slices in k-space by application of a read gradient and other gradients,
- setting the scanning direction of said slices in such a manner that tissue outside the area of interest is not covered, and
- positioning said slices in lengthwise direction obtaining a staggered arrangement of said slices such that the beginning and the end positions of each of said slices are at least approximately within the area covered by the slices before rotation.

8. A computer program product according to Claim 7, comprising rotating the slices uniformly over a predetermined angle in order to obtain said oblique relationship.

9. A computer program product according to claim 7 or 8, comprising providing of a uniform offset along a line perpendicular to the direction of the slice for lines to be scanned within each of said slices.

1/2

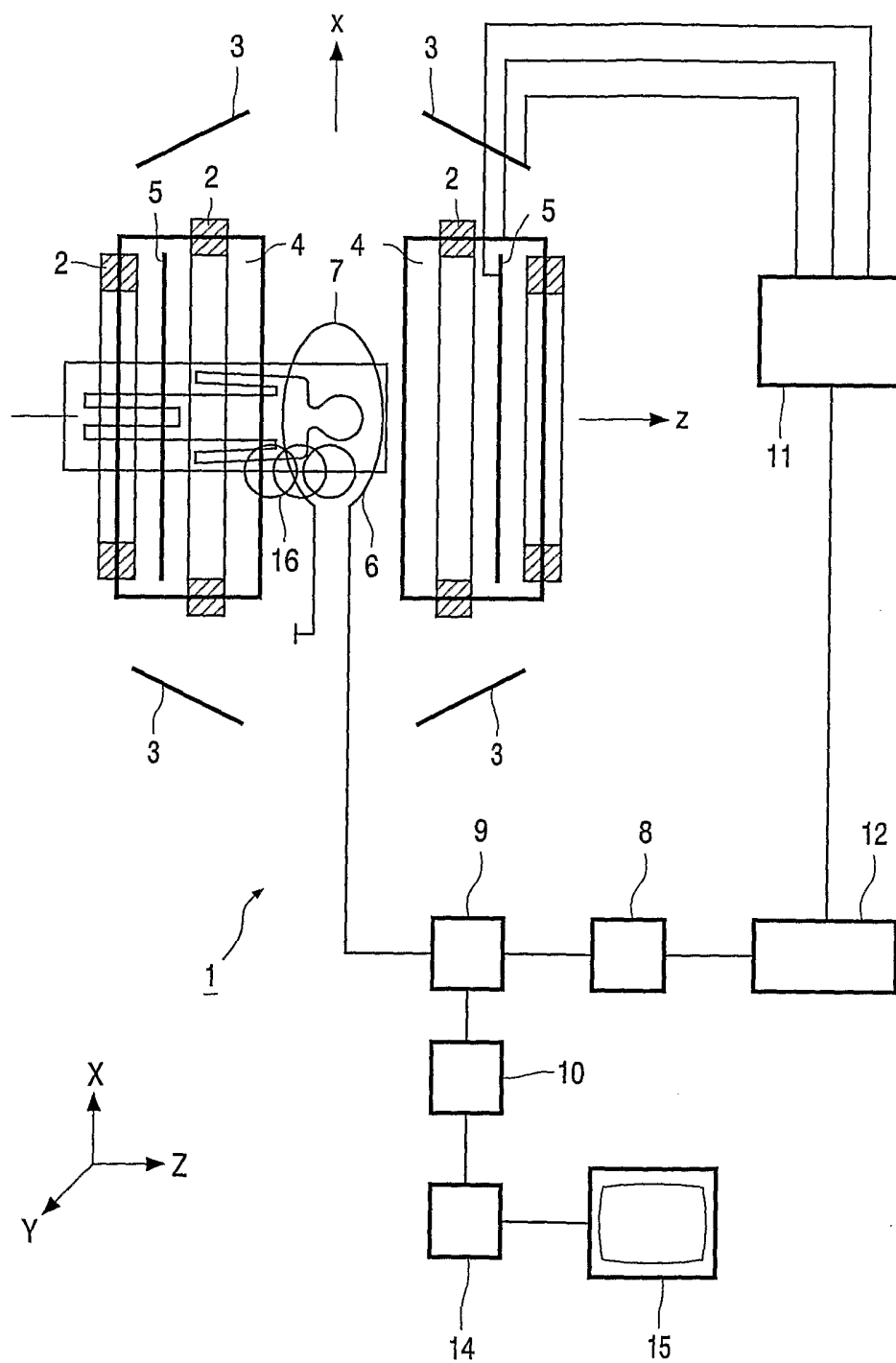

FIG. 1

2/2

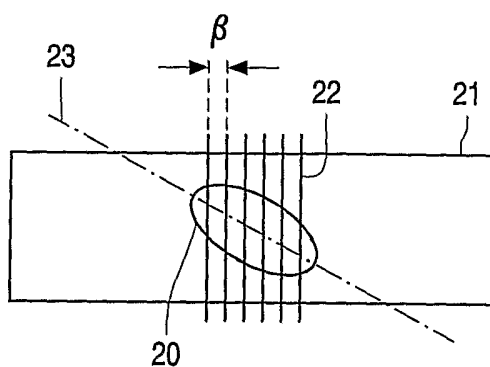

FIG. 2a

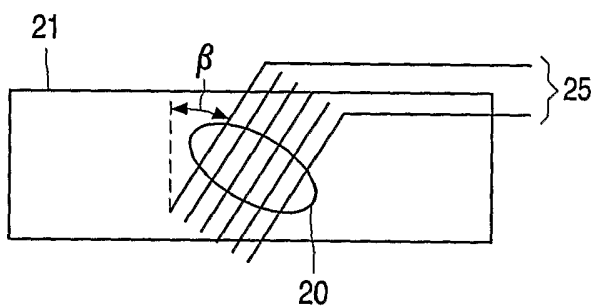

FIG. 2b

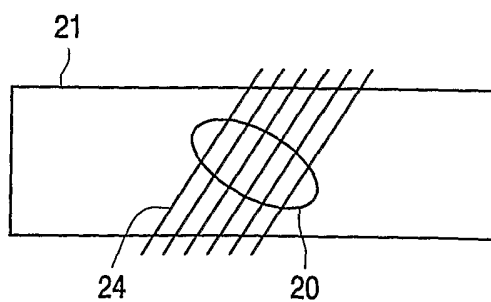

FIG. 2c

INTERNATIONAL SEARCH REPORT

Internatic ion No

PCT/IB 03/02162

A. CLASSIFICATION OF SUBJECT MATTER
IPC 7 G01R33/561

According to International Patent Classification (IPC) or to both national classification and IPC

B. FIELDS SEARCHED

Minimum documentation searched (classification system followed by classification symbols)
IPC 7 G01R

Documentation searched other than minimum documentation to the extent that such documents are included in the fields searched

Electronic data base consulted during the international search (name of data base and, where practical, search terms used)

INSPEC, WPI Data, PAJ

C. DOCUMENTS CONSIDERED TO BE RELEVANT

Category °	Citation of document, with indication, where appropriate, of the relevant passages	Relevant to claim No.
X	D.K. SODICKSON ET AL.: "Accelerated Coronary MRA ..." PROC. ISMRM, 1999, page 1249 XP002255495 the whole document	1-9
X	D.J. LARKMAN ET AL.: "Use of Multi-coil Arrays ..." PROC. ISMRM, 1999, page 91 XP002255496 the whole document	1-9
X	WO 88 04058 A (FONAR CORPORATION) 2 June 1988 (1988-06-02)	5-9
A	abstract claims 1-6,10-14 figures 1,5,7	1-4
	-/--	

Further documents are listed in the continuation of box C.

Patent family members are listed in annex.

° Special categories of cited documents :

- *A* document defining the general state of the art which is not considered to be of particular relevance
- *E* earlier document but published on or after the international filing date
- *L* document which may throw doubts on priority claim(s) or which is cited to establish the publication date of another citation or other special reason (as specified)
- *O* document referring to an oral disclosure, use, exhibition or other means
- *P* document published prior to the international filing date but later than the priority date claimed

- *T* later document published after the international filing date or priority date and not in conflict with the application but cited to understand the principle or theory underlying the invention
- *X* document of particular relevance; the claimed invention cannot be considered novel or cannot be considered to involve an inventive step when the document is taken alone
- *Y* document of particular relevance; the claimed invention cannot be considered to involve an inventive step when the document is combined with one or more other such documents, such combination being obvious to a person skilled in the art.
- *Z* document member of the same patent family

Date of the actual completion of the international search

25 September 2003

Date of mailing of the international search report

20/10/2003

Name and mailing address of the ISA

European Patent Office, P.B. 5818 Patentlaan 2
NL - 2280 HV Rijswijk
Tel. (+31-70) 340-2040, Tx. 31 651 epo nl,
Fax: (+31-70) 340-3016

Authorized officer

Volmer, W

INTERNATIONAL SEARCH REPORT

Internatic
ication No
PCT/IB 03/02162

C.(Continuation) DOCUMENTS CONSIDERED TO BE RELEVANT		
Category °	Citation of document, with indication, where appropriate, of the relevant passages	Relevant to claim No.
X	WO 02 04971 A (KONINLIJKE PHILIPS ELECTRONICS N.V.) 17 January 2002 (2002-01-17)	5-9
A	claims 1-4,6,7 figure 2	1-4
A	M. WEIGER ET AL.: "Cardiac Real-Time Imaging Using SENSE" MAGNETIC RESONANCE IN MEDICINE, vol. 43, 2000, pages 177-184, XP002255497 the whole document	1-9

INTERNATIONAL SEARCH REPORT

International Application No
PCT/IB 03/02162

Patent document cited in search report		Publication date		Patent family member(s)	Publication date
WO 8804058	A	02-06-1988	WO	8804058 A1	02-06-1988
WO 0204971	A	17-01-2002	US	6479996 B1	12-11-2002
			WO	0204971 A2	17-01-2002
			EP	1299740 A2	09-04-2003