

(No Model.)

O. B. WILSON.
LOOP FOR COW BELLS.

No. 463,565.

Patented Nov. 17, 1891.

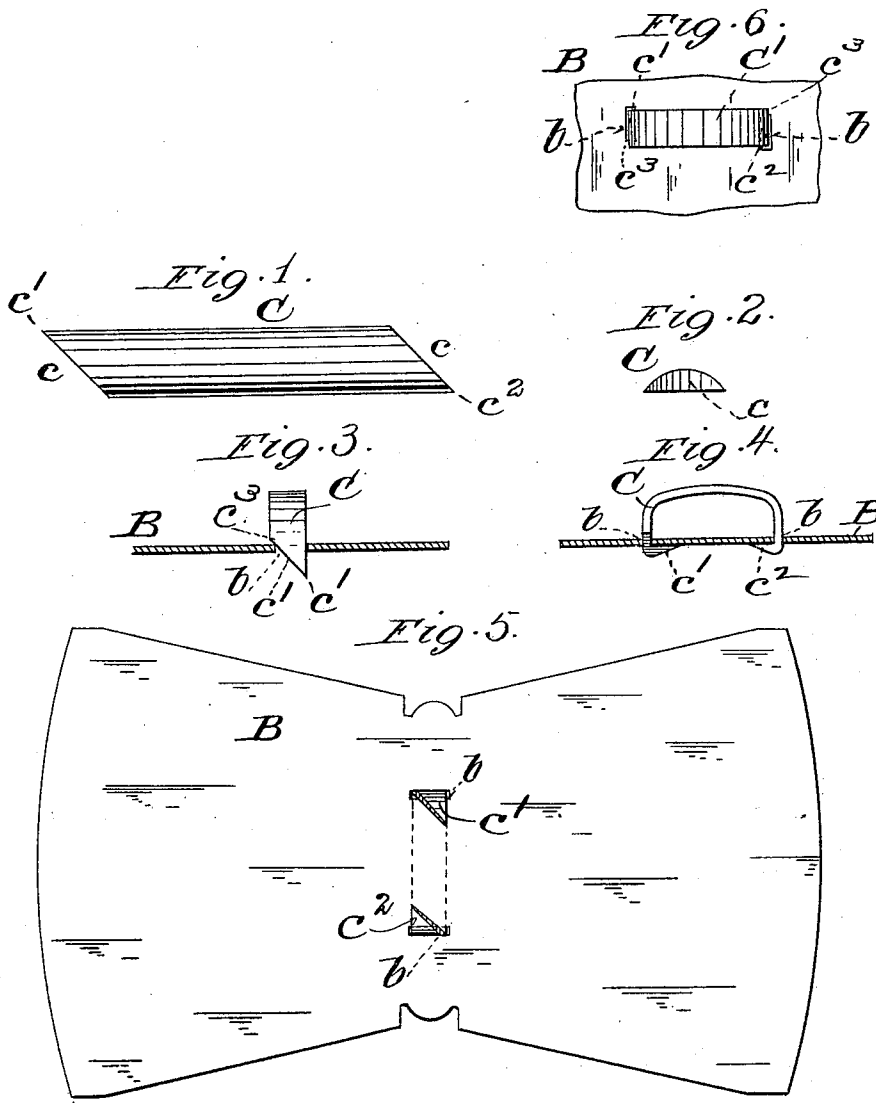

WITNESSES
Edward W. Furrell
A. Bonville.

INVENTOR
Oscar B. Wilson
by E. D. Moody his atty

UNITED STATES PATENT OFFICE.

OSCAR B. WILSON, OF COLLINSVILLE, ILLINOIS.

LOOP FOR COW-BELLS.

SPECIFICATION forming part of Letters Patent No. 463,565, dated November 17, 1891.

Application filed July 31, 1891. Serial No. 401,310. (No model.)

To all whom it may concern:

Be it known that I, OSCAR B. WILSON, of Collinsville, Illinois, have made a new and useful Improvement in Loops for Cow-Bells, of which the following is a full, clear, and exact description.

Hitherto in the construction and attachment of loops for cow-bells the practice has been substantially as follows: The pieces from which the loops were made were cut from a metallic rod of suitable size and cross-sectional shape, and after being cut off the pieces were properly bent into loops and then attached to the blanks, and the blanks were subsequently formed into bells.

The present improvement is based upon an analogous practice—that is, the loops are formed from pieces cut from rods, and after being formed the loops are secured to the blanks and the blanks are shaped and finished as heretofore. The special shape of the loop and the mode of attaching it to the blank, however, vary materially from the previous usage; and it is to such shape and method that the present improvement especially relates, substantially as is hereinafter set forth and claimed, aided by the annexed drawings, making part of this specification, in which—

Figure 1 is a plan view of the improved loop-piece; Fig. 2, an end view of the same; Fig. 3, a view showing the improved loop in end elevation applied to the blank but its points not yet clinched; Fig. 4, a side elevation of the same, the points clinched; Fig. 5, a bottom view of the blank having the loop attached, and Fig. 6 a top view of the loop attached to the blank. The views are not all upon the same scale.

The same letters of reference denote the same parts.

To more readily define the present improved construction the old form of loop is represented at A, Fig. 3. In cutting the loop-piece A' from the rod a tenon *a* is formed at each end of the piece. The tenon is formed in the middle of the end of the piece with a shoulder *a'* *a'* at each side of the tenon. The piece is then bent to form a loop, which is attached by inserting the tenons in perforations *b* in the blank B, from which the bell is ultimately formed. The loop is then secured by riveting the tenons on the under side of the blank,

substantially as is indicated by the broken lines *a*², Fig. 3. This practice, which in some respects is desirable, is not free from objections. A piece of the rod is wasted with every cutting. To form the described tenon *a* requires a piece of the rod at least one-fourth of an inch in length to be cut out between the successive loop-pieces, for as a tenon occurs at each end of a loop-piece the tenons upon successive pieces cannot in practice be formed without at the same time cutting out of the rod an intermediate piece of iron of the length mentioned. Furthermore, it requires special machinery to form the described tenons, and the dies of said machinery are liable to get out of order. Another objection is that the tenons must be carefully headed or the loop is liable to work loose from the bell. By means of the present improvement the loop-piece can be readily cut without waste from the rod, the cutting can be effected by means of ordinary tools, and the loop can be readily and securely attached to the blank, and all so that the cost of the loop and the operation are materially reduced.

C represents the improved loop-piece. It is formed by cutting the rod obliquely, substantially as shown at *c*. The bar is always sheared the same way, causing the two bevels *c c* at the ends, respectively, of the piece C to be parallel. In this manner each piece C has a pointed end *c'* at one side of the piece and another pointed end *c''* at the other side of the piece. The loop is then formed by bending the piece C into the form C', Figs. 6, 7, and 9, and the loop is attached by inserting its pointed ends in the perforations *b* in the blank B, and the loop is then secured to the blank by clinching its ends *c' c''* upon the under side of the blank, substantially as shown in Figs. 7 and 8. The piece C being wider than the perforations *b*, the pointed ends of the loop in attaching the loop to the blank cannot, as seen in Fig. 6 and also in Fig. 9, entirely enter the perforations, and a portion *c³* of each of the ends *c' c''* remains above the blank and serves as a shoulder to hold the loop in place upon the outer side of the blank. These shoulders *c³*, as seen in Fig. 9, come, respectively, upon opposite sides of the loop. The loop is thereby steadied laterally. Owing to their pointed form, the ends *c' c''* can be

wedged tightly into the perforations *b b*, and when said ends are finally clinched, as described, the loop is secured very rigidly and effectually to the blank. At the same time
5 the entire operation can be readily performed and with comparatively unskilled labor.

I claim—

1. The combination of the blank and the loop, said blank having perforations narrower
10 than said loop, and said loop having its ends beveled, inserted part way through said perforations, and clinched upon the under side of said blank, substantially as described.

2. The combination of the perforated blank and the loop having the beveled and pointed
15 ends, said loop being wider than said perforations, and said loop ends being wedged in said perforations and clinched upon the under side of said blank, substantially as described.

Witness my hand this 27th day of July, 20
1891.

OSCAR B. WILSON.

Witnesses:

C. D. MOODY,
A. BONVILLE.