

April 25, 1967

J. M. SCHWENDENER

3,315,760

ACOUSTIC DAMPING DRIVE FOR PULSATO ROTOR

Filed April 12, 1966

2 Sheets-Sheet 1

FIG. 1.

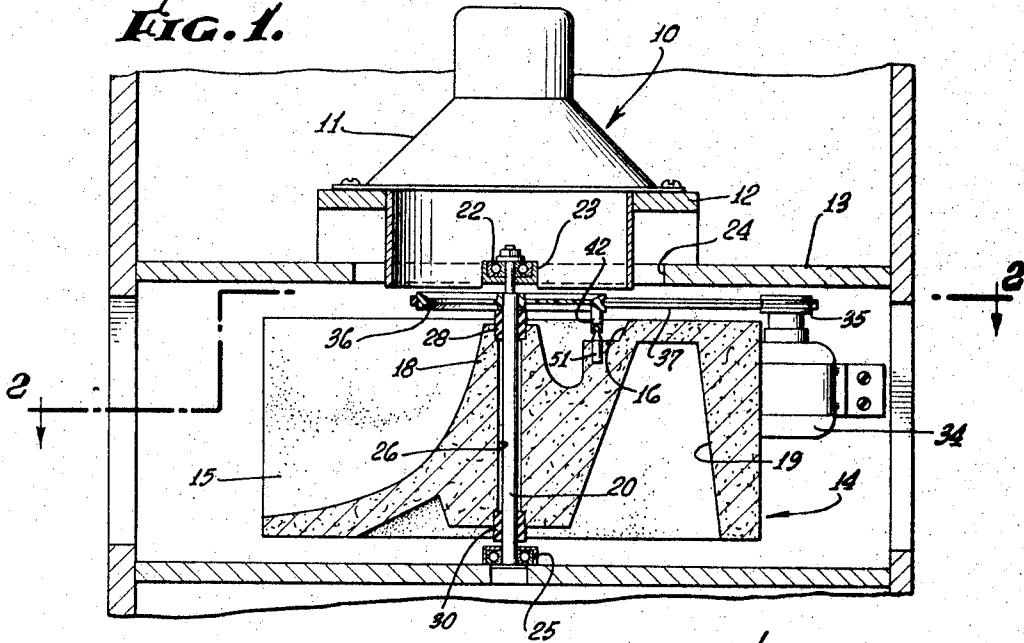
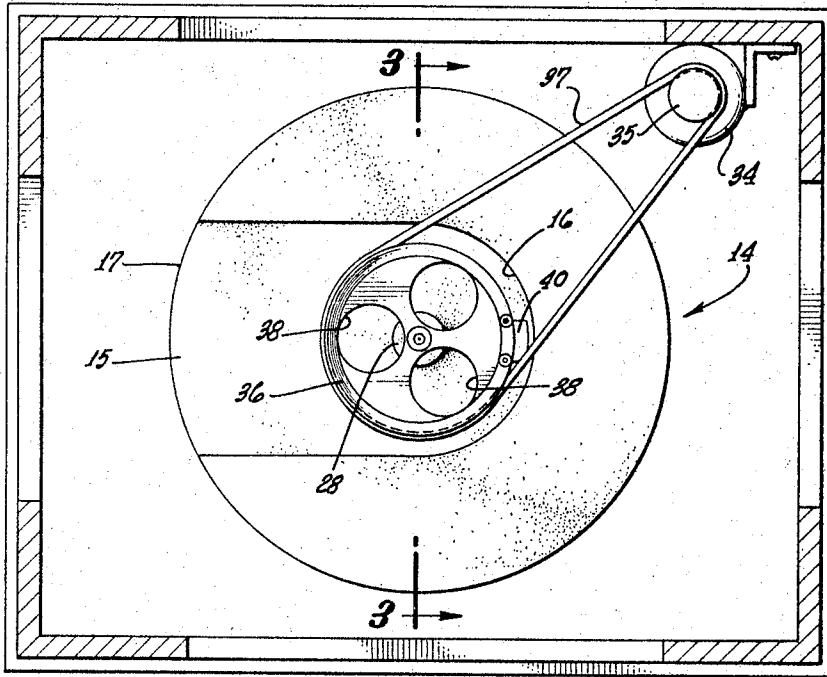

FIG. 2.



INVENTOR.
JACOB M. SCHWENDENER
By *Flem and Flem*
ATTORNEYS.

April 25, 1967

J. M. SCHWENDENER

3,315,760

ACOUSTIC DAMPING DRIVE FOR PULSATO ROTOR

Filed April 12, 1966

2 Sheets-Sheet 2

FIG. 3.

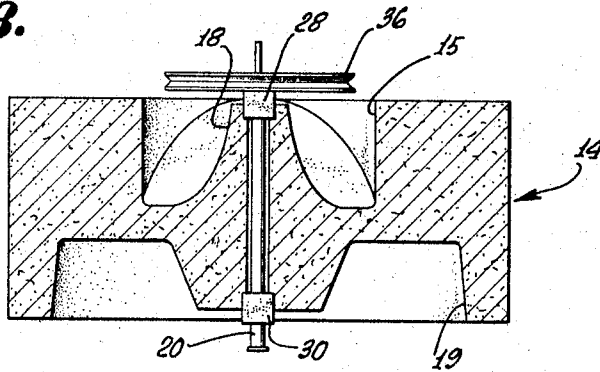

FIG. 4.

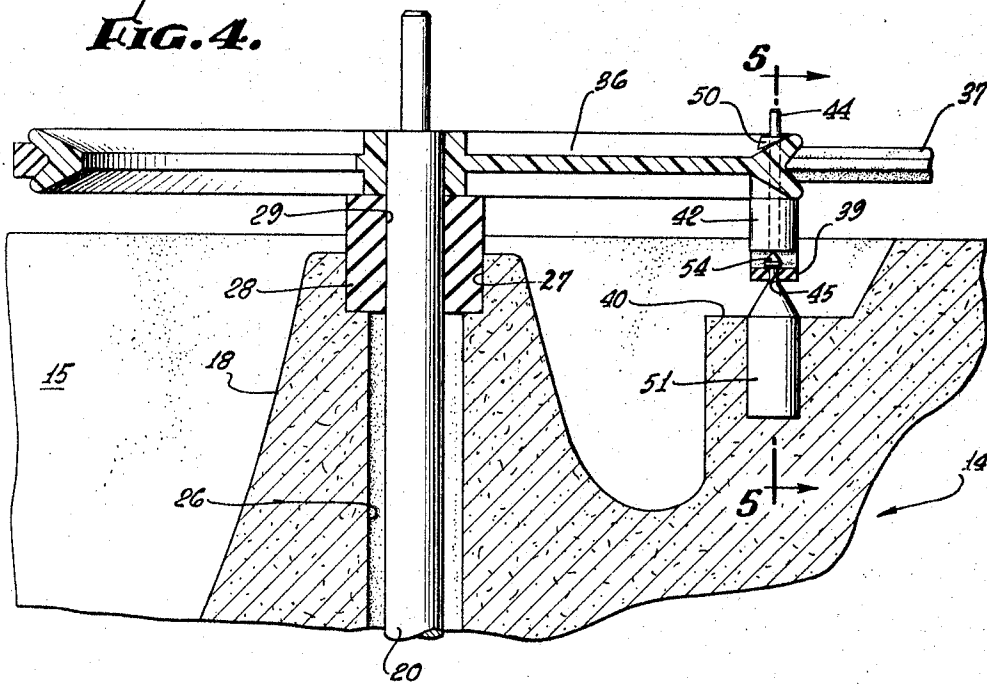
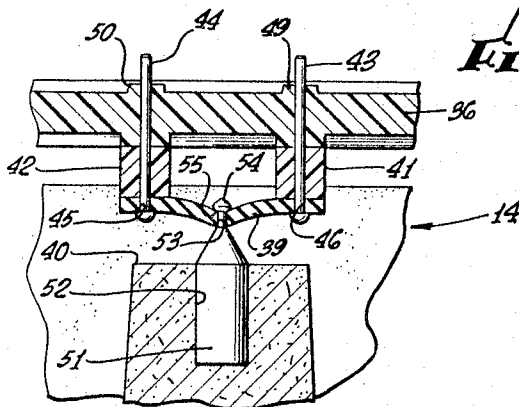

FIG. 5.



INVENTOR.
JACOB M. SCHWENDENER
By *Flem and Flem*
ATTORNEYS.

1

2

3,315,760
**ACOUSTIC DAMPING DRIVE FOR
 PULSATO ROTOR**

Jacob M. Schwendener, Glendale, Calif., assignor to
 Columbia Broadcasting System, Inc., New York, N.Y.,
 a corporation of New York

Filed Apr. 12, 1966, Ser. No. 542,113
 12 Claims. (Cl. 181—27)

This invention relates to rotary apparatus for producing tremolo or vibrato, and such as shown, for example, in United States Letters Patent No. 3,174,579, issued Mar. 23, 1965, to Donald J. Leslie.

In said prior patent, there is shown and described a rotary drum having a sound channel therein, the sound channel having a throat at the axis of the device registering with a stationary speaker, and having a mouth or sound emitting opening located laterally of the axis. Tremolo and vibrato is imparted to the sound by virtue of the orbital movement of the sound channel opening. Speaker drums of the type shown in said patent have been made entirely of molded expanded polystyrene in order to provide a low inertia structure capable of quickly reaching operating speed. A device of this type is also quite economical to manufacture.

It has been found that a speaker drum made of material such as molded expanded polystyrene itself acts as an efficient sound radiator in that any extraneous vibrations set up in the material itself result in squeaks and other noises. I have found that pulley itself transmits noises and vibrations to the speaker drum. Accordingly, the primary object of this invention is to provide an improved coupling between the rotary power source and the speaker drum characterized by high acoustic impedance whereby pulley noises and the like are adequately attenuated.

Another object of this invention is to provide a speaker drum of this character that can be easily made with simple components.

This invention possesses many other advantages, and has other objects which may be made more clearly apparent from a consideration of one embodiment of the invention. For this purpose, there is shown a form in the drawings accompanying and forming a part of the present specification, and which drawings, are true scale. This form will now be described in detail, illustrating the general principles of the invention; but it is to be understood that this detailed description is not to be taken in a limiting sense, since the scope of this invention is best defined by the appended claims.

Referring to the drawings:

FIGURE 1 is an axial sectional view of the speaker system incorporating the present invention;

FIG. 2 is a sectional view taken along a plane corresponding to line 2—2 of FIG. 1;

FIG. 3 is a sectional view taken along the plane corresponding to line 3—3 of FIG. 2;

FIG. 4 is an enlarged sectional view showing a portion of the apparatus illustrated in FIG. 1; and

FIG. 5 is a fragmentary sectional view taken along a plane indicated by line 5—5 of FIG. 4.

In FIG. 1 there is illustrated a speaker 10 cooperable with the output of electronic organ (not shown). The speaker 10 has a generally conical frame 11 mounted on an inverted U-shaped ported cabinet bracket 12. The bracket 12 is supported on a ported cabinet partition 13.

Located beneath the partition 13 is a pulsato drum 14. The drum 14 is made of molded expanded polystyrene. The drum 14 provides the sound channel 15 (see also FIG. 2) having a throat 16 intended to register with the speaker 10 and having a sound emitting opening 17. The sound channel 15 generally is of arcuate shape. How-

ever, a generally conical baffle or deflector 18 rises from the channel, and extends along the axis of the device. The deflector 18 serves to provide a broad radiation pattern for the high frequency sounds as described in said prior Leslie Patent No. 3,174,549.

The undersurface of the drum 14 is provided with suitable cavities 19 in order to reduce the weight of the drum 14. These cavities are carefully located in order to provide dynamic balance.

The drum 14 is mounted upon a shaft 20. One end of the shaft projects upwardly of the drum at the axis of the throat opening 16 where it is supported by a bearing structure 22. The bearing structure 22 is carried on a cross beam 23 that extends across the port 24 of the partition 13. The lower end of the shaft 20 projects beneath the drum 14 and is supported by a bearing structure 25.

The shaft 20 extends with substantial clearance through an axial opening 26 in the drum 14. The upper end of the bore 26 is enlarged to provide a square recess 27 that receives a correspondingly shaped neoprene or rubber plug 28. The plug 28 has a through aperture 29 that has a running fit with the shaft 20. The lower end of the shaft 20 is similarly supported by a neoprene plug 30 (see FIGS. 1 and 3). The plugs 28 and 30 are preferably saturated with a fine lubricant, and any vibration of the shaft 20 is isolated from the drum 14 since the shaft 20 is capable of angular or sliding movement relative to the plugs 28 and 30.

The drum is rotated independently of the shaft 20. A motor 34 (FIGS. 1 and 2) rotates the drum at a rate of from five to eight revolutions per second in order to produce the characteristic pulsato. A pulley 35 carried on the motor shaft is connected to a pulley 36 press fitted on the drum shaft 20. A belt 37 is provided for this purpose. The pulley 36 as shown in FIG. 2 partially overlies the throat 16. Apertures 38 minimize interference.

As shown in FIG. 5, the pulley 36 carries a strap 39 that extends beneath the rim of the pulley and along a flat 40 formed at the upper end of the channel 15 behind the deflector 18. The strap 39 may be made of rubber-like resilient yielding material having acoustic damping characteristics. The ends of the strap 39 extend across the short posts 41 and 42. Pins 43 and 44 extend through apertures 45 and 46 in the strap 39, extend through the posts, and are press fitted in aperture bosses 49 and 50 of the pulley 36.

The central portion of the strap 39 is engaged by a headed pin 51. This pin is tightly fitted in a recess 52 that opens at the surface 40. The pin 51 has a shank part that extends through an aperture 53 formed in the center of the strap 39. A head 54 of the pin provides a shoulder 55 to lock the parts against separation. A rotary coupling is thus effected from the pulley 36 to the drum 14 via the strap 39 and the pin 51. Since the pin 51 is far from the axis of rotation, only a modest force need be transmitted from the strap 39 in order to develop the requisite rotary torque.

Any vibrations or noises imparted to the pulley 36 will not be transmitted to the drum 14 for the reason that the coupling between the pulley and the drum 14 is accomplished through the acoustic damping strap 39 and for the reason that the shaft 20, which does not transmit torque, but merely supports the pulley 36 and is isolated from the drum by the slidable mounting in the plugs 28 and 30. The strap stretches and compresses, but no part of the strap which undergoes a change in configuration contacts the drum. Accordingly no scraping is produced.

The inventor claims:

1. In combination: a support; a pulsato drum; means supporting said drum for rotation about an axis; drive

3

means for imparting rotating torque to said drum; a resilient flexible member anchored entirely on the drive means, said member having an intermediate part capable of flexing movement relative to the drive means; a substantially rigid and non-flexible element attached to the drum and engaging the said intermediate part of said member whereby noises and vibrations of the drive means are isolated from the drum.

2. In combination: a support; a shaft mounted on the support; a pulsato drum member mounted on the shaft and capable of relative angular movement with respect to said shaft; a transmission member mounted on said shaft and rotatable about the axis of said shaft; means for imparting rotary motion to said transmission member; and a coupling between said transmission member and said drum member, including a flexible resilient element, means anchoring said element entirely on one of said members, and substantially rigid means carried by the other of said members and engaging said flexible resilient element at a place spaced from said anchoring means whereby vibrations and noises of said transmission member are isolated from said drum member.

3. The combination as set forth in claim 2 in which said flexible resilient element is a strap anchored at opposite ends.

4. The combination as set forth in claim 2 in which said flexible resilient element is a strap anchored at opposite ends on said transmission member, said drum member carrying a headed pin engaging an aperture in said strap at a place intermediate said ends.

5. In combination: a cabinet; a shaft mounted on the cabinet; a pulsato drum member made of material having the characteristics of molded expanded polystyrene, and having a throat and a sound emitting opening, said drum member having a bore extending axially of the throat, and accommodating said shaft with clearance; a pair of bearings carried by the drum member at opposite ends of said bore, and having apertures providing a running fit with said shaft; a pulley member mounted on said shaft; means for rotating said pulley member; and a connection between said members at a place spaced from said shaft, and comprising a flexible resilient element anchored en-

4

tirely on one of said members, and substantially rigid means carried by the other of said members and engaging said resilient element whereby vibrations and noises of said pulley member are isolated from said drum member.

6. The combination as set forth in claim 5 in which said bearings are rubber elements containing lubricant.

7. The combination as set forth in claim 5 in which said flexible resilient element is a strap anchored at opposite ends.

8. The combination as set forth in claim 5 in which said flexible resilient element is a strap anchored at opposite ends beneath the rim of said pulley member, and said substantially rigid means including a headed pin carried by said drum engaging an aperture in said strap located at a place intermediate its anchored ends.

9. The combination as set forth in claim 8 in which said headed pin has a part accommodated in a recess of said drum member.

10. The combination as set forth in claim 6 in which said flexible resilient element is a strap anchored at opposite ends.

11. The combination as set forth in claim 6 in which said flexible resilient element is a strap anchored at opposite ends beneath the rim of said pulley member, and said substantially rigid means including a headed pin carried by said drum engaging an aperture in said strap located at a place intermediate its anchored ends.

12. The combination as set forth in claim 11 in which said headed pin has a part accommodated in a recess of said drum member.

References Cited by the Examiner

UNITED STATES PATENTS

1,818,131	8/1931	Harrison.	
1,847,181	3/1932	Harrison.	
1,917,633	7/1933	Burt.	
2,547,725	4/1951	Thompson	274—39
3,174,579	3/1965	Leslie	181—27

STEPHEN J. TOMSKY, *Primary Examiner.*