

No. 852,823.

PATENTED MAY 7, 1907.

S. W. CRAMER.  
HUMIDIFYING AND AIR CONDITIONING APPARATUS.  
APPLICATION FILED APR. 18, 1906.

3 SHEETS—SHEET 1.

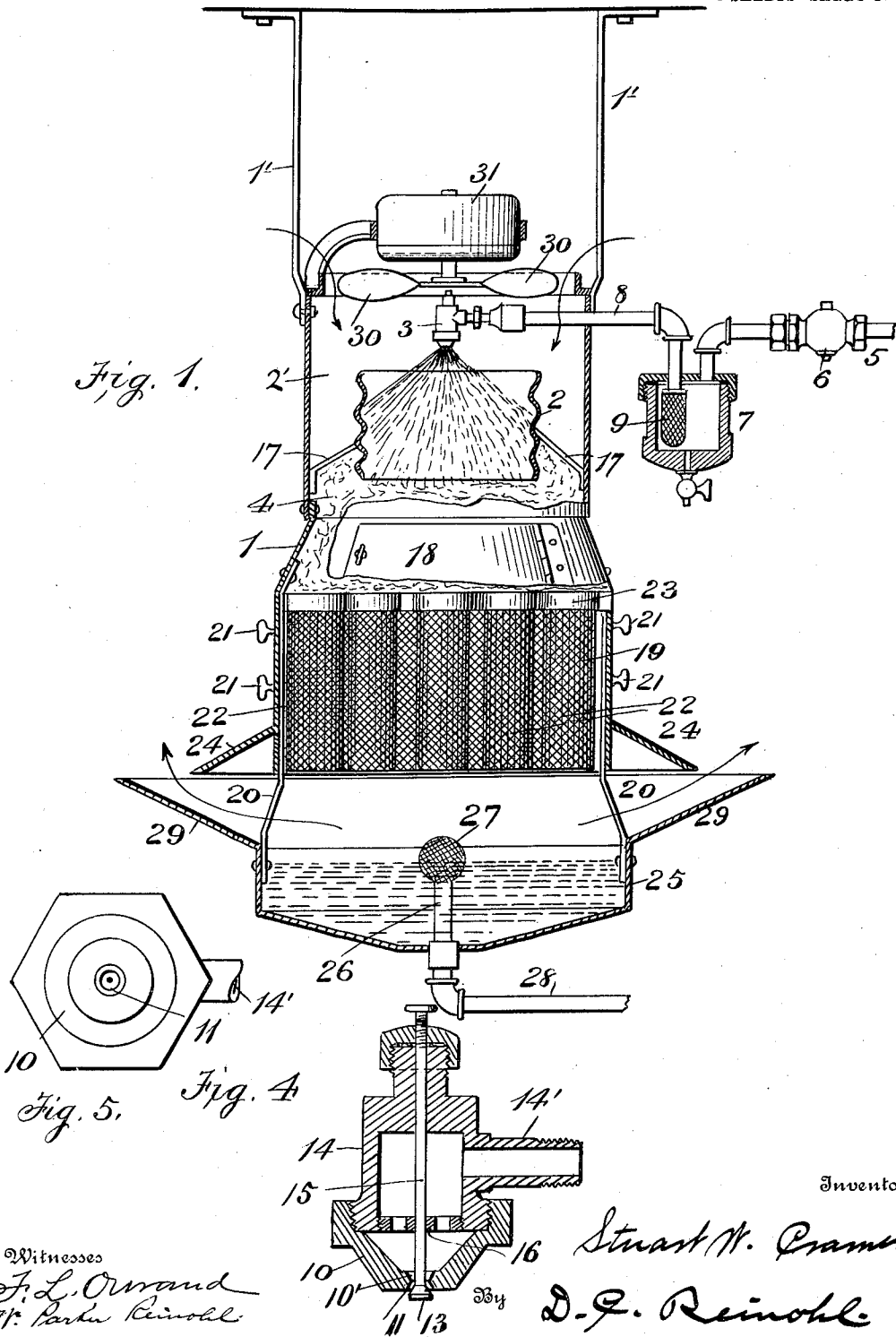

Witnesses  
J. L. Orvand  
W. Parker Reinold

Inventor  
Stuart W. Cramer.  
D. G. Reinold  
Attorney

No. 852,823.

PATENTED MAY 7, 1907.

S. W. CRAMER.  
HUMIDIFYING AND AIR CONDITIONING APPARATUS.

APPLICATION FILED APR. 18, 1906.

3 SHEETS—SHEET 2.

*Fig. 2.*

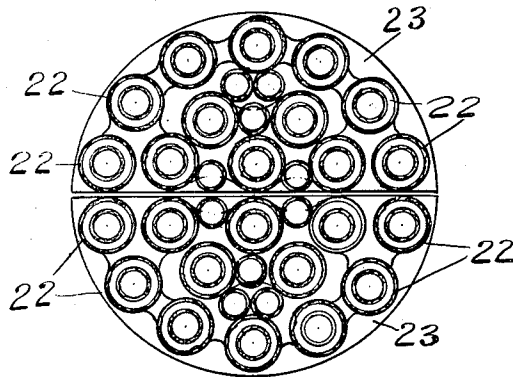
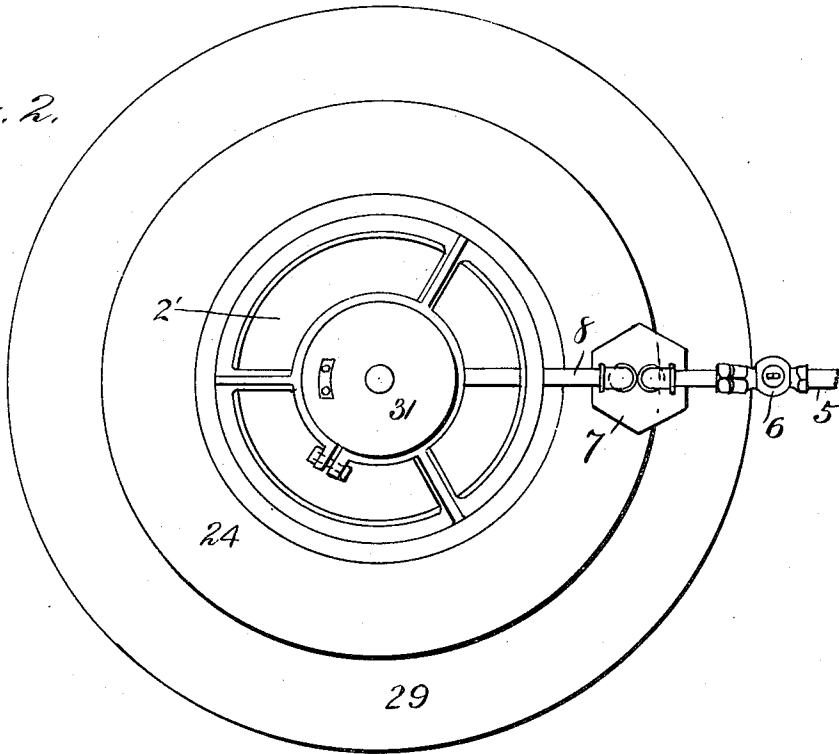

*Fig. 3.*

Witnesses  
*F. L. Ovrande*  
*W. Parker Reinold*

Inventor  
*Stuart W. Cramer*  
By *D. C. Reinold*  
Attorney

No. 852,823.

PATENTED MAY 7, 1907.

S. W. CRAMER.

HUMIDIFYING AND AIR CONDITIONING APPARATUS.

APPLICATION FILED APR. 18, 1906.

3 SHEETS—SHEET 3.

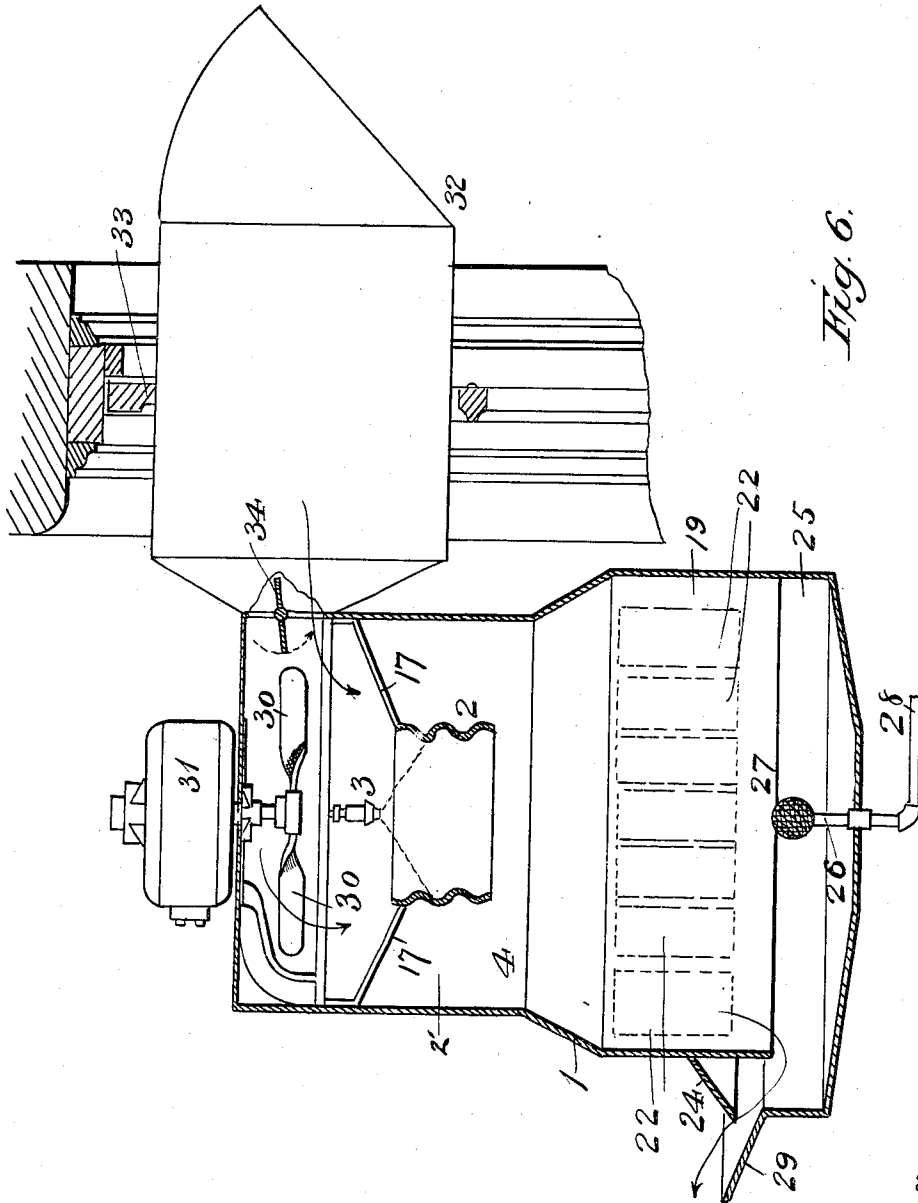

Fig. 6.

Witnesses  
F. L. Curran  
W. Parker Reynolds

Inventor  
Stuart W. Cramer.  
by D. C. Reinold  
Attorney

# UNITED STATES PATENT OFFICE.

STUART W. CRAMER, OF CHARLOTTE, NORTH CAROLINA.

## HUMIDIFYING AND AIR-CONDITIONING APPARATUS.

No. 852,823.

Specification of Letters Patent.

Patented May 7, 1907.

Application filed April 18, 1906. Serial No. 312,453.

*To all whom it may concern:*

Be it known that I, STUART W. CRAMER, a citizen of the United States, residing at Charlotte, in the county of Mecklenburg and State of North Carolina, have invented certain new and useful Improvements in Humidifying and Air-Conditioning Apparatus; and I do hereby declare the following to be a full, clear, and exact description of the invention, such as will enable others skilled in the art to which it appertains to make and use the same.

My invention relates to humidifying and air conditioning apparatus for textile and other factories, is designed for use in systems of automatic regulation of the humidity and temperature in such factories, disclosed in my Patent No. 811,383, dated January 30th, 1906 and No. 813,083, dated February 20th, 1906, and the invention consists in certain improvements in construction, which will be fully disclosed in the following specification and claims.

This apparatus is designed for placing along the wall between the windows in a room in a factory, mill, or other building, taking air from the outside, and by a system of dampers also from the inside in varying proportions, as may be desired. The incoming air is thus treated or uniformly conditioned so that its introduction into the room does not disarrange or disturb the conditions that the whole object of the apparatus seeks to establish.

It is a well-known fact that ventilating textile factory buildings by opening windows or doors, is not only injurious from a manufacturing standpoint interfering with the proper running of the work, but also positively disarranges and disturbs the normal uniform conditions of the fibers of the material which are required for the most favorable conditions to manufacturing. It is also a well known fact that air containing lint, dust, and other impurities when blown or conducted past wetted surfaces, or sheets of water, will not readily part with its impurities. The surface tension of the water operates in antagonism to air cleansing, at least so far as relieving it of any dry foreign matter is concerned. In my apparatus therefore, when the air is first drawn into the apparatus by a fan, I provide for a thorough dousing or wetting of the air by a strong spray or cloud of vapor; in the second place, realizing that water directly discharged into

the atmosphere in however finely an atomized condition, is not a benefit, but, on the contrary, an objection until it is evaporated, and realizing furthermore, the practical impossibility of evaporating fine particles of water when discharged or blown into the atmosphere, especially after a moderate percentage of humidity has been attained, I next provide for removing all of the coarse particles of water, including the fine spray and vapor, from the air, that it may issue from the apparatus colorless and free from even a fog-like appearance, but thoroughly cleansed from all solid impurities. Furthermore, just before the air issues from the apparatus, it impinges directly and normally upon the surface of a body of water, that will catch or arrest any coarse foreign matter that may have escaped being deposited upon the wet surfaces to which reference has already been made.

In my present apparatus I provide first a casing in which to treat the air; a fan for drawing in and forcing through the casing a current of air either from without the building or from within the building itself, or a mixture of both inside and outside air; a spray chamber in which the air is driven through a dense cloud of fine spray and vapor; a collecting, condensing and evaporating chamber, in which wetted woven fabrics of an absorbent and evaporative nature, geometrically or otherwise arranged to the best advantage, are kept moist by the spray deposited on them by the current of air as it comes to them direct from the spray chamber. Said woven fabrics presenting surfaces upon which deleterious and foreign matter in suspension in the air are readily deposited by their having been wetted in the spray chamber; and finally, an open basin of water at the bottom of the casing, upon which water the air must impinge before it can issue radially from the casing, thus collecting the last traces of any coarse particles of lint, fly, sweepings, etc., that may have been too heavy to remain on the fabrics in the collecting chamber above, but which in their heavy and wetted condition are readily caught in the basin of water instead of being allowed to skip out (as a stone is glanced or ricocheted on a pool or water) with the air in the casing, which has heretofore been the case in apparatus of this type.

The invention will be fully disclosed in the following specification and claims.

110

In the accompanying drawings, which form part of this specification:—Figure 1 represents a vertical section partly in elevation of an apparatus embodying my invention. Fig. 2 a top plan view of the same. Fig. 3 a plan view of one form of support for the woven fabrics. Fig. 4 a vertical section of the spray-head. Fig. 5 a bottom plan view of the nozzle on the spray-head, and Fig. 6 a vertical section partly in elevation, showing a conduit extending through a window for supplying air from outside a building.

Reference being had to the drawings and the designating characters thereon, the numeral 1 indicates the outer casing of sheet metal, shown suspended on supports 1', but may be supported in various ways, according to the position of the apparatus, 2 a concentrically arranged and circumferentially corrugated annular deflector for breaking up the cone shaped sheet of water discharged by the spray-head 3 in a very fine spray into the spray-chamber 4, below or beyond the deflector, and thereby producing within said chamber a dense cloud of fine spray for thoroughly dousing or wetting the air passing through the chamber. The water is supplied through a pipe 5, having stop cock 6, a filter or settling chamber 7, pipe 8 having a wire gauze strainer 9 within the filter, and the spray-head 3. The spray-head is provided with a nozzle 10 having a discharge orifice 10' and a valve seat 11 provided with a number of fine grooves (not shown) to separate the water into very fine streams. The valve 13 is a smooth inverted cone. It is obvious that the same result can be achieved by having the valve grooved, and the valve seat smooth. The body 14 of the spray-head is provided with a branch 14', to which the pipe 8 is connected, and the valve stem 15 is guided in the perforated diaphragm 16, is screw-threaded at its upper end to afford vertical adjustment of the valve for regulating the amount of water passing through the valve. The annular deflector 2 is supported on bars 17.

18 is a door in the casing affording access to the spray-chamber, and to the condensing, collecting and evaporating chamber 19. This part of the casing is made in two parts or semi-cylinders and are secured to the stays 20, by thumb screws 21, to facilitate the insertion and removal of the collecting and evaporating bodies 22 in said chamber. The bodies 22 are preferably tubular, made of woven fabric, and may be composed of two concentric members, as shown in Fig. 3, arranged in geometrical or other suitable manner and supported upon a frame 23, which may be semi-cylindrical, as shown in said Fig. 3, or of any other preferred construction. The bodies 22, are designed and constructed to be readily-removed from the casing for the

purpose of relieving them of the accumulated impurities collected from the air passing through the apparatus. When the air is drawn into the casing at the top by the fan and passes down into the spray chamber, it becomes thoroughly doused and saturated with the spray and is forced down through the condensing chamber, the air not only being thoroughly saturated with aqueous vapor, but also carrying mechanically in suspension a cloud of spray. This cloud of spray surrounds and comes in contact with the absorbent surfaces in the condensing chamber in such a manner that practically every particle of air comes into contact with these damp surfaces. Naturally then, the air gives up to the absorbent surfaces all the spray and moisture that is carried in suspension, retaining only what moisture there is in it completely assimilated. In other words the air is saturated, and is discharged in a perfectly colorless condition, though saturated, no moisture is visible.

24 is a drip-flange at the lower end of the casing to arrest any drops of water that may escape through the casing.

25 is a basin which contains the drip water from the apparatus, and overflows through the pipe 26, provided with a strainer 27, and pipe 28 which returns the water to its source of supply, by the use of a pump, not shown. The upper end of the basin 25 is provided with a flaring flange 29 to collect drip water, and direct the aqueous and colorless vapor discharged from the apparatus laterally therefrom.

The air is furnished to the apparatus by a fan 30 at the upper end of the casing, driven by an electric motor 31, or by any other preferred means. The air passes through and around the deflector 2, in contact with the highly comminuted particles of water within the deflector, and also passes through the fine mist or aqueous vapor in the annular chamber 2' surrounding the deflector and thereby receives its initial saturation.

In Fig. 6 I have shown the apparatus connected to a conduit 32, extending through a window 33 for supplying air from outside the building, and is provided with a valve 34 for regulating the quantity of air admitted.

In equipping a factory or mill, with part of the humidifiers communicating with the outside air, the supply of air to the room can be regulated so as to provide a constant supply of fresh air when desired. The moisture laden air passing through the apparatus is projected against the surface of the water in the basin 25 and is deflected laterally between the flanges 24 and 29, and any solid impurities which may have escaped the bodies 22 are arrested. When the water supply is cut off and the fan 30 is still kept running, thus forcing air down from the room through the apparatus, it operates, though to a lesser de-

gree, as an air cleansing device; it also, however, operates in the same manner as a condensing or cooling tower in stationary engineering practice. That is to say, that when the humidity of the atmosphere has reached a very high percentage, it will naturally yield up some of its moisture to the cold, wetted woven surfaces of the bodies 22, as it is blown past them. It is obvious, therefore, that the apparatus at such a time will operate as a condenser, abstracting much more moisture from the atmosphere than it adds to it by evaporation. As long as this condition exists, the apparatus reduces excessive humidity, paradoxical though it may seem, as well as at other times it operates as a humidifying device, raising the percentage of humidity. There is a point at which equilibrium will be established, and that is when the amount of water condensed is equaled by the amount of water evaporated; this point, as indicated by humidity percentage varies according to the temperature of the air.

The filling, as I may term it, for the condensing chamber may be made equally well of any absorbent material, such as cypress wood as well as of woven or knitted fabrics, as shown. Or it is obvious that this filling may be of metal or of solid tubular or other shaped surfaces, which, while it will be of a less efficient type, still does not depart from the spirit of my invention.

Having thus fully described my invention, what I claim is

1. In a humidifier, a casing comprising a spray-chamber, and a collecting and condensing chamber beyond the spray-chamber, means for supplying air to the casing, means for supplying spray to the air as it passes through the spray-chamber, a plurality of collecting and evaporating bodies for extracting the spray from the air in the condensing and collecting chamber and for the further saturation of the air before it issues from the casing, and means for collecting surplus water from the casing.

2. In a humidifier, a casing comprising a spray-chamber, and a collecting and condensing chamber beyond the spray-chamber, means for supplying air to the casing, means for supplying spray to the air as it passes through the spray-chamber, a plurality of

collecting and evaporative surfaces for extracting the spray from the air in the condensing and collecting chamber and for the further saturation of the air before it issues from the casing, means for removably supporting said collecting and evaporative surfaces in the casing, and means for collecting surplus water from the casing.

3. In a humidifier, a casing comprising a spray-chamber, means for supplying air to the casing, a spray-head within the spray-chamber, and means for supplying fluid to the spray-head; a collecting and condensing chamber beyond the spray-chamber and provided with a plurality of bodies arranged for removing the particles of spray from the current of air and for the further saturation of the air before it issues from the casing, and a drip or catch basin provided with means for removing surplus water.

4. In a humidifier, a casing comprising a spray-chamber, and a collecting and condensing chamber beyond the spray-chamber, means for supplying air to the casing, a spray-head within the spray-chamber, and means for supplying fluid to the spray-head; bodies arranged within the collecting and condensing chamber for removing the particles of spray from the air and for the further saturation of the air before it issues from the casing, and a drip or catch basin provided with means for removing surplus water.

5. In a humidifier, a casing, a spray-head, a concentrically arranged deflector having a circumferentially corrugated wall, an annular chamber around said deflector, a spray-chamber beyond the deflector and means for supplying fluid to the spray-head, a collecting and condensing chamber beyond the spray-chamber, bodies arranged within the collecting and condensing chamber for removing the particles of spray from the air and for the further saturation of the air before it issues from the casing, and a drip or catch basin provided with means for removing surplus water.

In testimony whereof I affix my signature, in presence of two witnesses.

STUART W. CRAMER.

Witnesses:

D. H. McCOLLOUGH, Jr.,  
D. W. LIEBENTHALER.