

G. VIRZI.
 TONE AMPLIFIER FOR STRINGED INSTRUMENTS.
 APPLICATION FILED OCT. 21, 1920.

1,412,584.

Patented Apr. 11, 1922.
 2 SHEETS—SHEET 1.

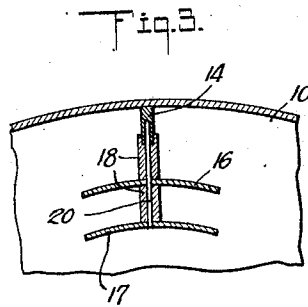
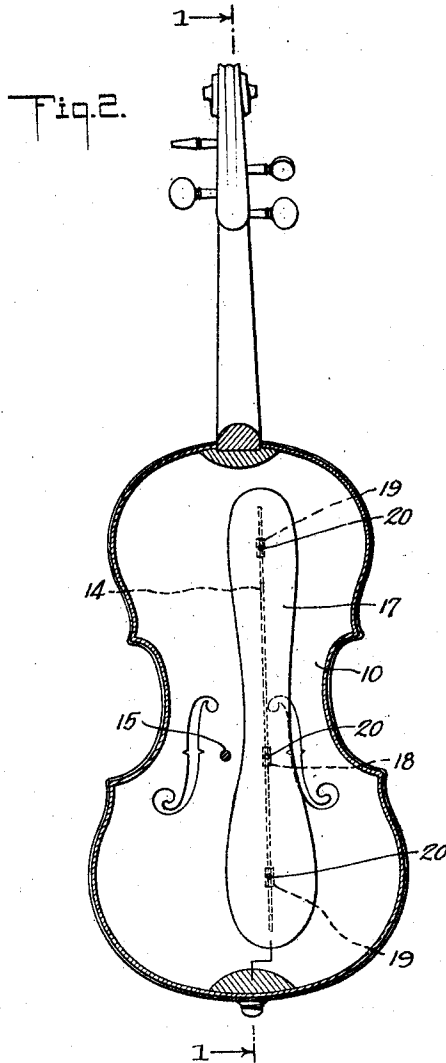
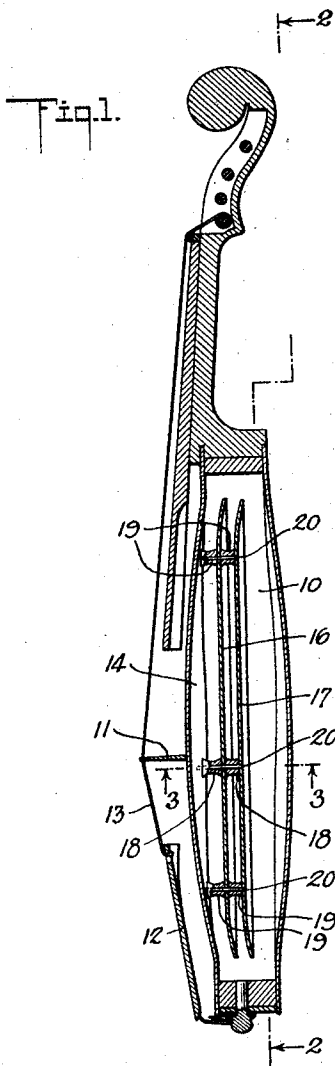

WITNESS
Frederick Diehl.

INVENTOR
Giuseppe Virzi
 BY *Geo. S. Seeler*
 ATTORNEY

G. VIRZI.
 TONE AMPLIFIER FOR STRINGED INSTRUMENTS.
 APPLICATION FILED OCT. 21, 1920.

1,412,584.

Patented Apr. 11, 1922.
 2 SHEETS—SHEET 2.

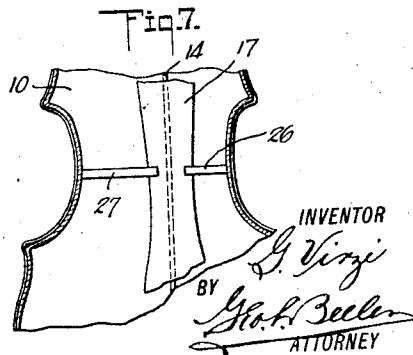
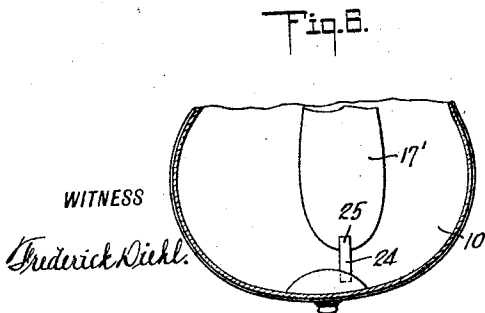
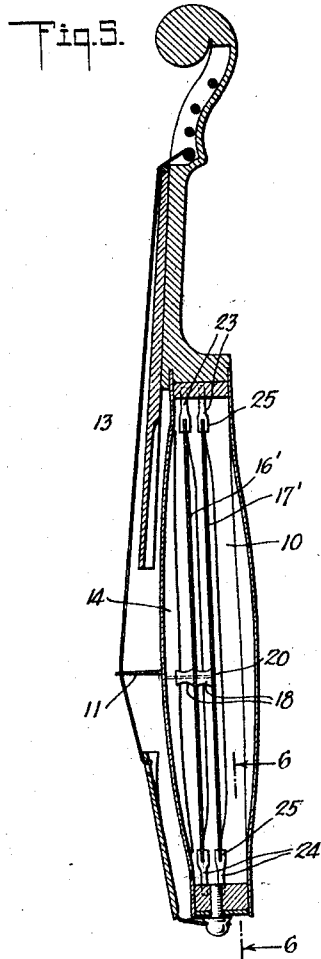
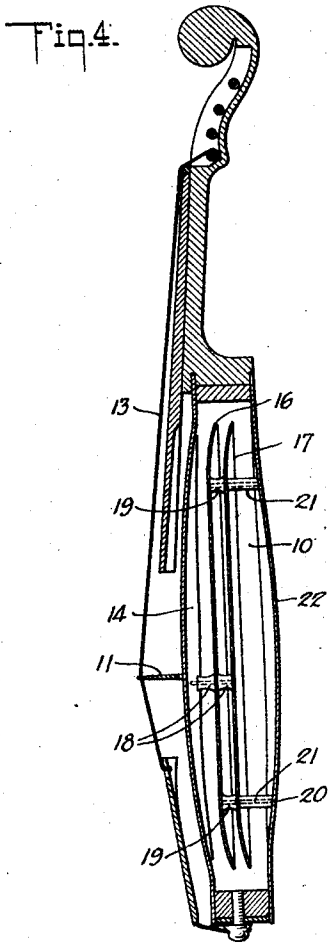

UNITED STATES PATENT OFFICE.

GIUSEPPE VIRZI, OF NEW YORK, N. Y.

TONE AMPLIFIER FOR STRINGED INSTRUMENTS.

1,412,584.

Specification of Letters Patent. Patented Apr. 11, 1922.

Application filed October 21, 1920. Serial No. 418,414.

To all whom it may concern:

Be it known that I, GIUSEPPE VIRZI, a subject of the King of Italy, but having declared my intention of becoming a citizen of the United States, and residing at 341 East 124th Street, New York city, in the county of New York and State of New York, have invented certain new and useful Improvements in Tone Amplifiers for Stringed Instruments, of which the following is a specification.

This invention relates to musical instruments and has particular reference to stringed instruments such as violins, guitars, cellos, and the like.

Among the objects of the invention is to provide simple and efficient means carried on or within the body of a musical instrument whereby the tones generated by the strings will be modified in timbre or quality and amplified in volume with respect to tones produced by similar instruments heretofore, and whereby my improved instruments are capable of producing sweeter, richer, and otherwise more pleasing results, than would be possible without my improvements.

With the foregoing and other objects in view the invention consists in the arrangement and combination of parts hereinafter described and claimed, and while the invention is not restricted to the exact details of construction disclosed or suggested herein, still for the purpose of illustrating a practical embodiment thereof reference is had to the accompanying drawings, in which like reference characters designate the same parts in the several views, and in which—

Figure 1 is a vertical longitudinal section on the line 1—1 of Fig. 2, indicating one preferred form of my invention.

Fig. 2 is a vertical transverse section on the line 2—2 of Fig. 1.

Fig. 3 is a horizontal section on the line 3—3 of Fig. 1.

Fig. 4 is a sectional view similar to Fig. 1 but indicating a modified form of my improvement.

Fig. 5 is another modified form.

Fig. 6 is a sectional detail on the line 6—6 of Fig. 5.

Fig. 7 is a transverse sectional detail, corresponding to a part of Fig. 2, but showing a further modification.

Referring now more specifically to the first set of figures I show a conventional musical instrument in the nature of a violin

and comprising a body 10, bridge 11, tail piece 12, strings 13, bass bar 14, and sounding post 15, all of which are or may be of conventional or well known construction.

Carried by any suitable portion of the body 10 are a plurality of devices in the nature of sounding boards, shown as associated with the bass bar 14 within the body. Any suitable number of such sounding boards, one or more, may be employed, and obviously they may be made of any suitable material, and they may be attached to any suitable parts of the instrument body. As shown in Figs. 1 and 3 the sounding boards 16 and 17 are attached first to the bass bar and secondly to each other and are spaced not only from each other but also from all other portions of the body. As shown best in Figs. 1 and 3 the sounding board 16 is attached to the bass bar by means of a plurality of studs 18 and 19, the stud 18 being located just within or below the bridge 11, while the studs 19 are located adjacent to the ends of the bass bar and spaced somewhat farther from the ends of the sounding board 16. These sounding boards may be of any suitable form in cross section and outline. As indicated they are of concavo-convex form in cross section and relatively long and slender and with rounded outlines in plan. Furthermore, as much as possible of the edge or outline of each sounding board is free or unattached with respect to all other parts of the structure.

The next sounding board 17 is shown as being similar in structure to the one before it, and it is attached to the sounding board 16 by means of studs 18 and 19 arranged similarly to or in alignment with those studs attached to the bass bar. The studs may be secured by any suitable means to the parts intended to be supported thereby. For this purpose I have used successfully glue for the ends of the studs in connection with a dowel pin 20 extending through both sounding boards and both aligned studs and projecting into the bass bar. This pin may be secured in place by glue or any other suitable means. The stud adjacent to the bass bar may be bifurcated and so straddle the bass bar if desired. Similar dowel pins are shown passing through the studs.

In Fig. 4 I show the sounding boards 16 and 17 attached to the bass bar 14 as described above, just beneath the bridge 11, but the ends of the sounding boards are not

attached to other portions of the bass bar. I show at 21 a pair of posts attached to the front and rear portions of the back 22 of the body, these posts being attached not far remote from the ends of the sounding board 17 and in alignment between the two sounding boards, and acting as spacers therefor the same as correspondingly located studs in Fig. 1. Dowel pins 20 may be used to extend through each pair of aligned posts and studs, thereby making most secure these several attachment means.

As will be appreciated from Fig. 4 the sounding boards will be effectively held in place for all practical purposes and yet they will have sufficient freedom of action to vibrate in harmony with the tones generated in the strings and transmitted to the body through the bridge.

In Figs. 5 and 6 I show a slight variation in sounding boards 16' and 17' and also in the means for supporting them. These sounding boards are attached to each other and to the bridge portion of the bass bar 14 by studs 18 and dowel pin 20 as in the other forms described. The head and tail ends, however, of these sounding boards are anchored to the head and tail portions respectively of the body by means of anchor pins 23 and 24. Each of these anchor pins has a forked end 25 embracing an end portion of a sounding board to which it is glued, while the other end of the pin is projected into a rigid portion of the body. It will be noted that in this form of the invention each sounding board is straight or flat longitudinally at its ends, but curved transversely intermediate of its ends.

The purpose of Fig. 7 is to indicate that the means for supporting either of any number of sounding boards may be attached to

any convenient or suitable relatively rigid parts of the instrument body. In this figure the sounding boards are shown as being supported about midway between their end by means of laterally projecting anchor pins 26 and 27 secured to the side portions of the instrument. Other fastening means may be attached between the sounding boards and other parts of the instrument in order to make secure the support for the sounding boards.

I claim:

1. In a musical instrument including a hollow body, the combination of a plurality of sounding boards in addition to the body, means including one or more studs extending between the sounding boards to hold them in spaced relation to one another, and means to secure the sounding boards to the body.

2. A device as set forth in claim 1 in which the instrument body includes a bass bar and the means for securing the sounding boards to the body includes a stud extending between one of the sounding boards and the bass bar, the sounding boards except for said stud being spaced from the bass bar.

3. In a musical instrument including a hollow body having a bass bar, the combination with said body of a plurality of sounding boards within the hollow body, and means to secure the sounding boards to the hollow body, said securing means including studs fixed to the sounding boards intermediate of their ends, the studs being in alignment with one another, and a dowel pin extending through the aligned studs and fixed at one end to said bass bar, and having connection with all of the sounding boards.

GIUSEPPE VIRZI.