

(19) (KR)
(12) (B1)

(51) 。 Int. Cl.7
B60K 15/073

(45)
(11)
(24)

2003 10 17
10-0401444
2003 09 30

(21) 10-2000-0051081
(22) 2000 08 31

(65)
(43)

2000-0064225
2000 11 06

(73)

152

(72)

302

110 703

160 1

106 805

2

106 602

103 1109

(74)

:

(54)

가 (10)
가

가 (11)
가

가

3b

1 (a)(b)
2
3 (a)
(b)
(c)
4
5
< >
10 : 11 :
20 : 30 :
40 : 50 :

가

가

가

1 (a)(b) 2 (Return) (Returnless)

(Reservoir)(100) (Turbine Pump)(101)

(Supply Flow) (100) (Engine)(102) (102) (Return) 가

(100) (Return Jet)(103) (Jet)(103) (104) 가

(101) (102) (Cycle) (100)

(104) 가 (104)

2 (104) (Vertical) 가 (100)

(104) 가 (100)가 (104) (104)

(104) 가 (104) (Steel) (Plastic) 가

(105) 가 (104) (100)

(104) (100)

가

1 , 2 가

3

4 가 5

6

가

가

1 (1) (10)가 (11) (11) (10) (10) (1) (1)

0)가 (11) (11) (1) (10) (12)가 (4)

30 (31) (10) (10) (21) (30) (21) (10) (32)

50 (10) (10) (21) (13)가 (21) (20)가 (1)

(51)가 55 (51) (13) (52) (50) (Supply FI (R

ow) , 56 eturn Flow) (10) (40)

(13) (10) 1 (a)(b) (55) (1)

(32)가 (31) (10) (56) (30) (10) (1)

(1) (10) (10) (11) (1) 가 (1)

(1)가 (11) 가 (40)가 (40)

(10) (11) (1) (12) (1)

(10) (51) 가 (52) (1)

(50) (51) (50) (20) (52) (50)가

(1) (10) (1) (10) (10) (10)

가 (1) (1) (10) (10) (11) (1)

4 (10) (11) (1)

(50) (10) (11) (1)

5 (50) (1)

가 , 가 , 가

- (57)
1. (10)가 (1) , (10) (13)가 (1) ; (10) (11) (1) 가 (10) (10) (11) (40)가 (12)가 ; (1) 가
 - 2.
 - 3.
 4. 1 (10) (50) (52)

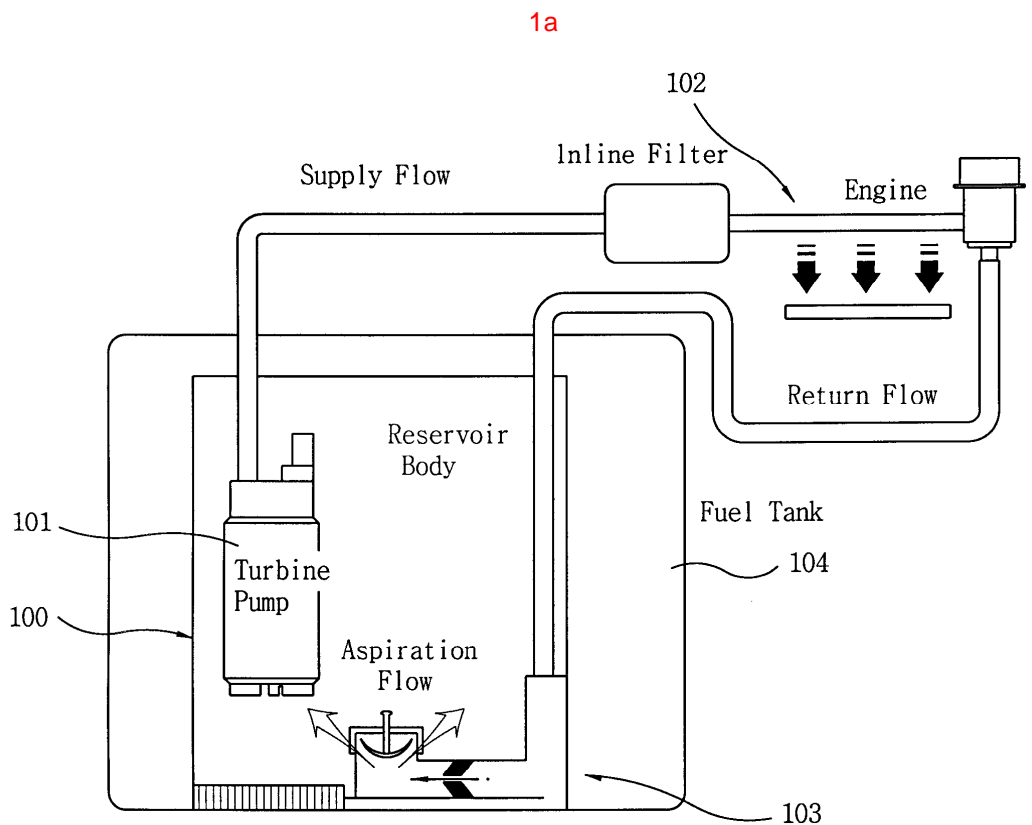

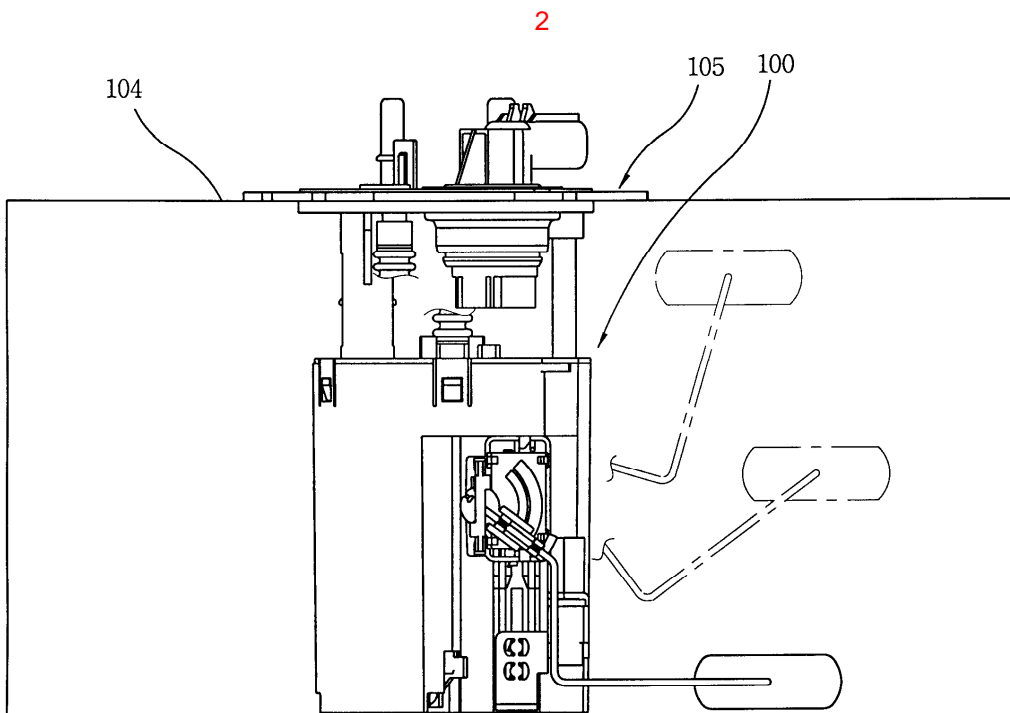
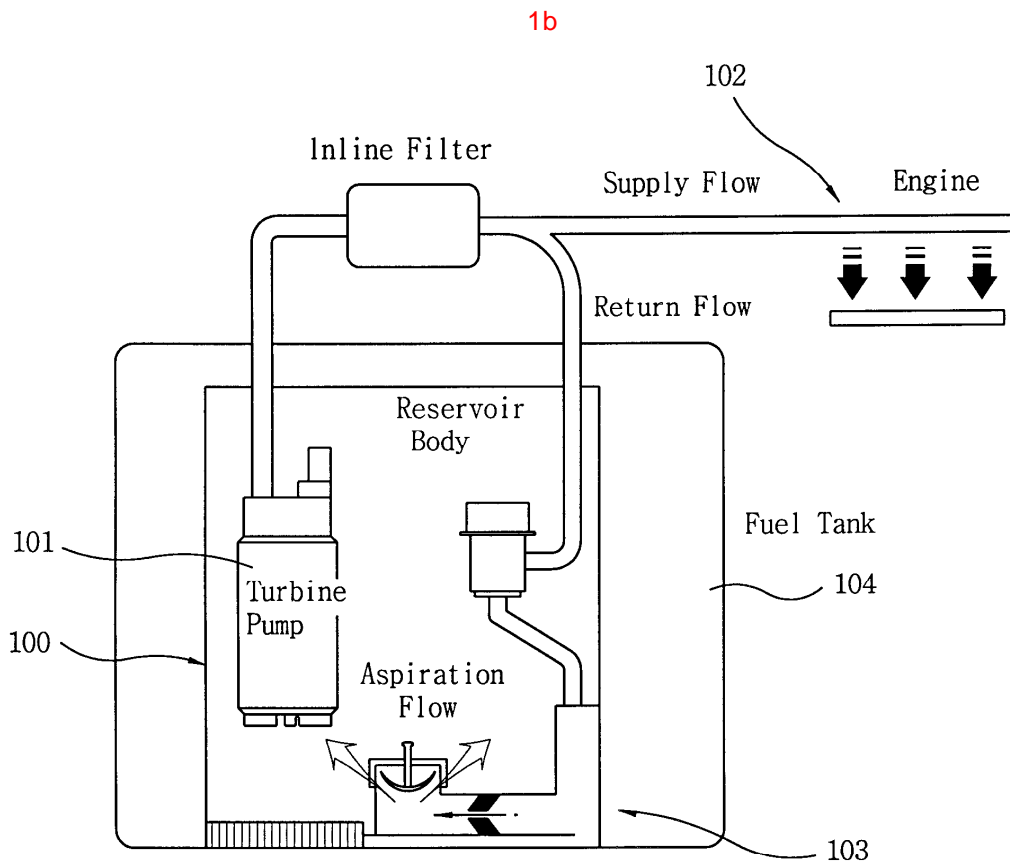

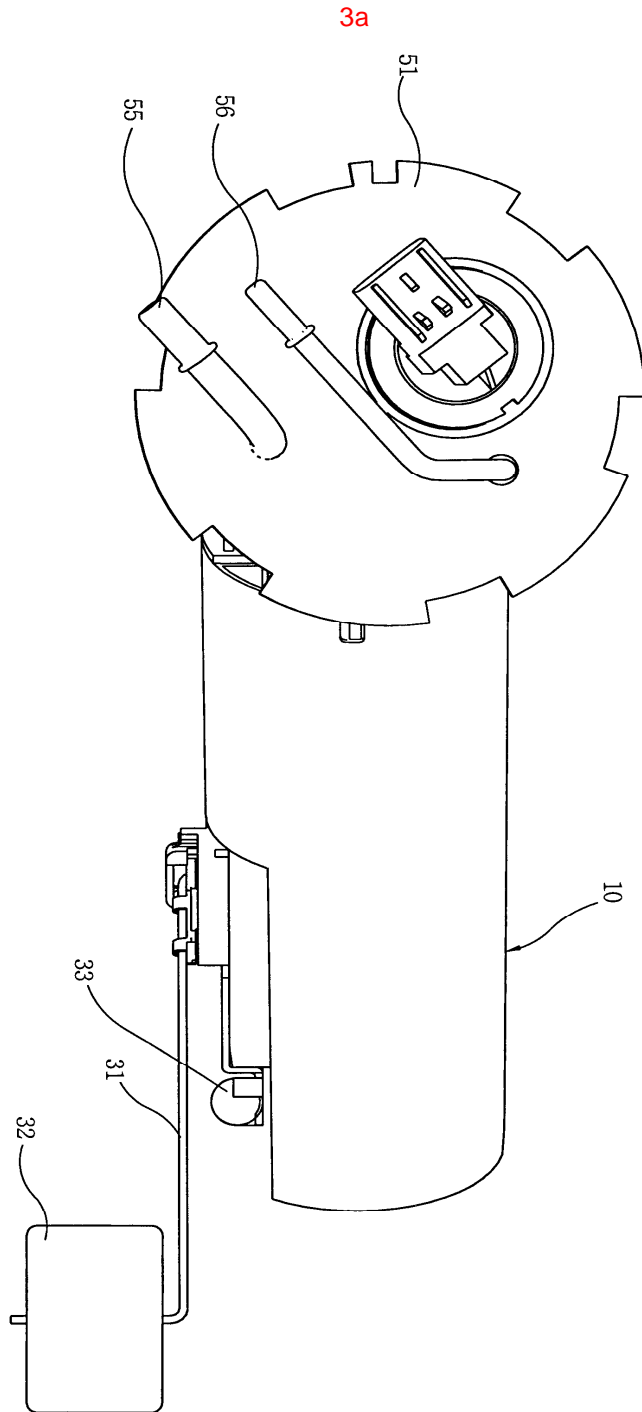

3b

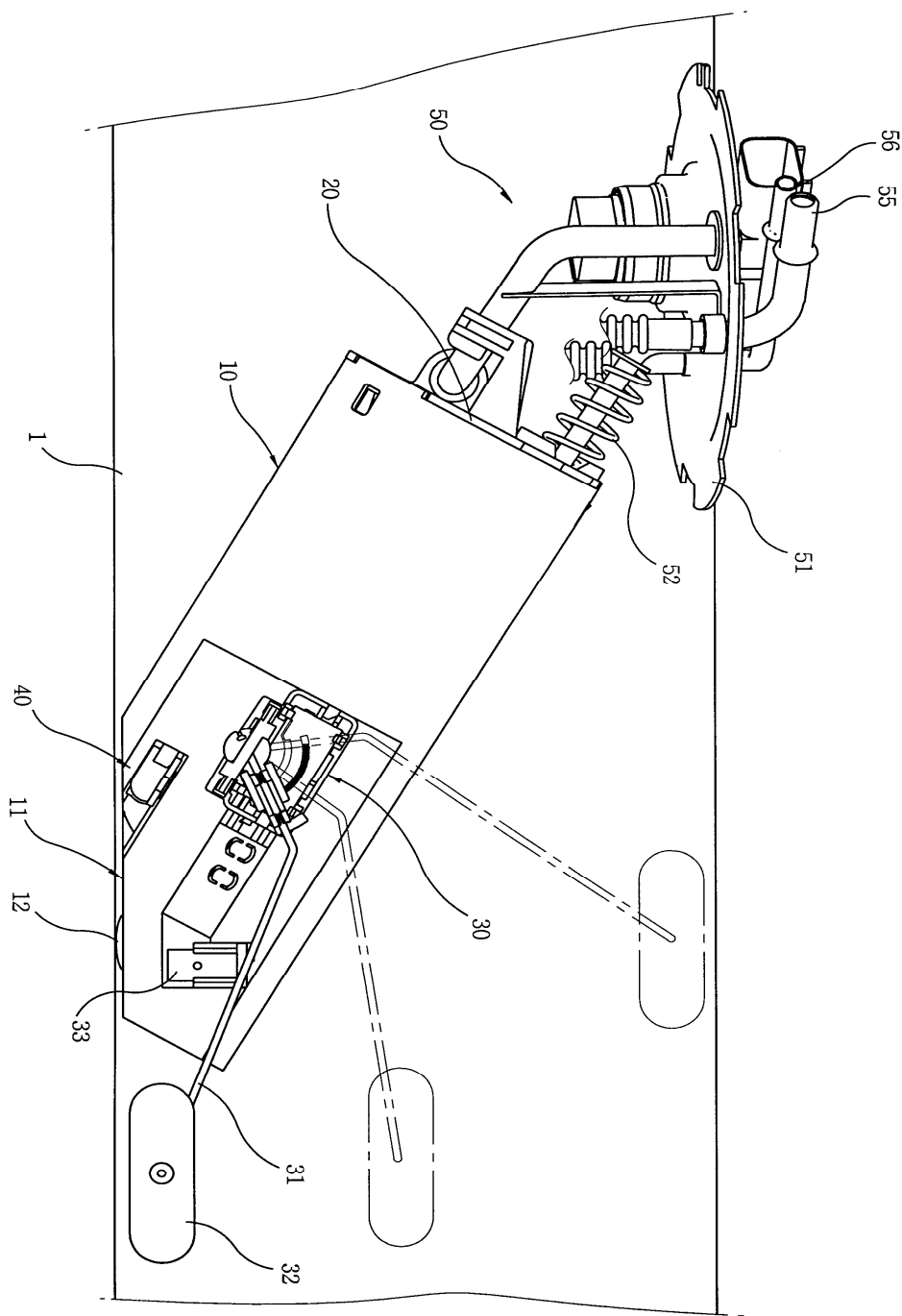

3c

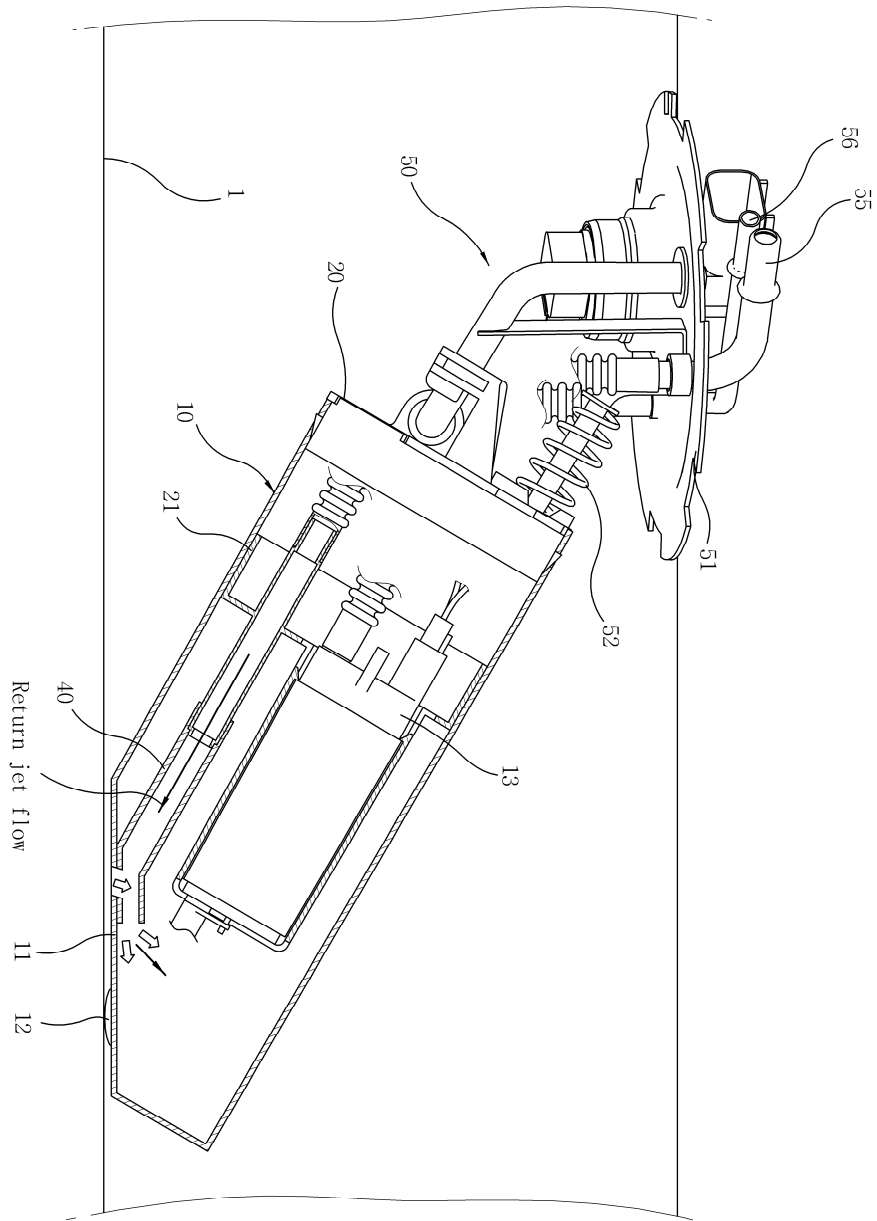

4

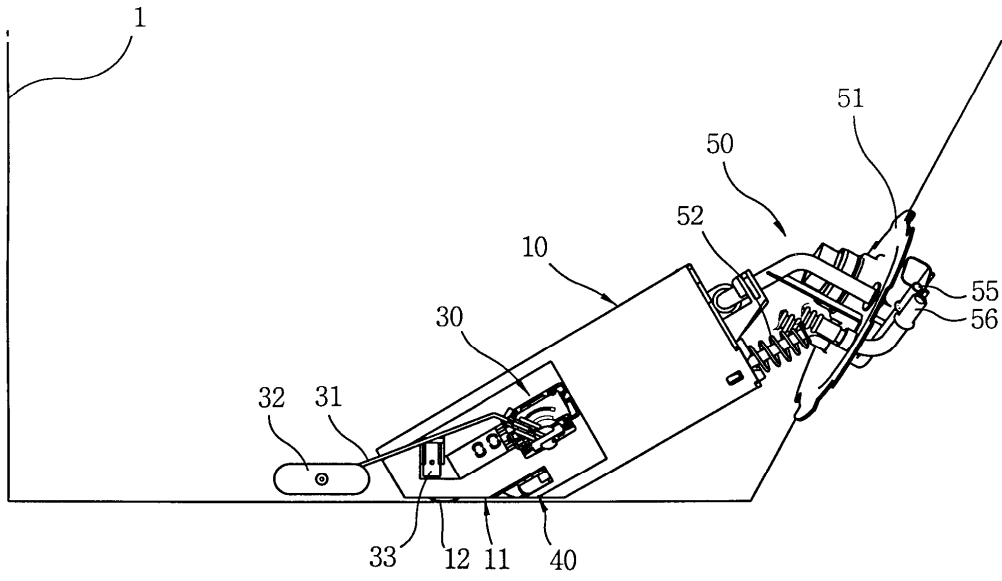

5

