



US009182588B2

(12) **United States Patent**
Shin et al.

(10) **Patent No.:** **US 9,182,588 B2**
(45) **Date of Patent:** **Nov. 10, 2015**

(54) **ELECTROWETTING DISPLAY DEVICE HAVING BANKS OF DIFFERENT HYDROPHILICITIES AND METHOD FOR MANUFACTURING THE SAME**

(71) Applicant: **Liquavista B.V.**, Eindhoven (NL)

(72) Inventors: **Sang-Min Shin**, Cheonan-si (KR); **Woo-Song Kim**, Hwaseong-si (KR); **Chang-Ku Hua**, Seoul (KR); **Soo-Jin Park**, Seoul (KR); **Mun-Soo Park**, Suwon-si (KR)

(73) Assignee: **Amazon Technologies, Inc.**, Reno, NV (US)

(*) Notice: Subject to any disclaimer, the term of this patent is extended or adjusted under 35 U.S.C. 154(b) by 377 days.

(21) Appl. No.: **13/730,096**

(22) Filed: **Dec. 28, 2012**

(65) **Prior Publication Data**

US 2013/0170008 A1 Jul. 4, 2013

(30) **Foreign Application Priority Data**

Dec. 30, 2011 (KR) 10-2011-0147311

(51) **Int. Cl.**

G02B 26/02 (2006.01)
G02B 26/00 (2006.01)

(52) **U.S. Cl.**
CPC **G02B 26/005** (2013.01)

(58) **Field of Classification Search**
CPC G02B 26/005; G02B 26/004; G02B 2207/115; G02B 26/02; G09G 2300/0426; G09G 3/3433
USPC 359/228, 291, 295, 665; 345/84
See application file for complete search history.

(56) **References Cited**

U.S. PATENT DOCUMENTS

7,746,540 B2 6/2010 Lo et al.
2009/0046082 A1* 2/2009 Jacobson et al. 345/204
2013/0329274 A1* 12/2013 Yang et al. 359/290

* cited by examiner

Primary Examiner — James Phan

(74) *Attorney, Agent, or Firm* — Lee & Hayes, PLLC

(57) **ABSTRACT**

Disclosed is an electrowetting display device including a plurality pixels. Each pixel includes a pixel electrode, a hydrophobic layer, a hydrophobic fluid, and a bank adapted to limit the range of movement of the hydrophobic fluid. The bank has a hydrophobic bank surface and a hydrophilic bank surface, which face each other. The hydrophobic fluid is moved from the hydrophilic bank surface towards the hydrophobic bank surface by the application of a voltage to the pixel electrode.

20 Claims, 10 Drawing Sheets

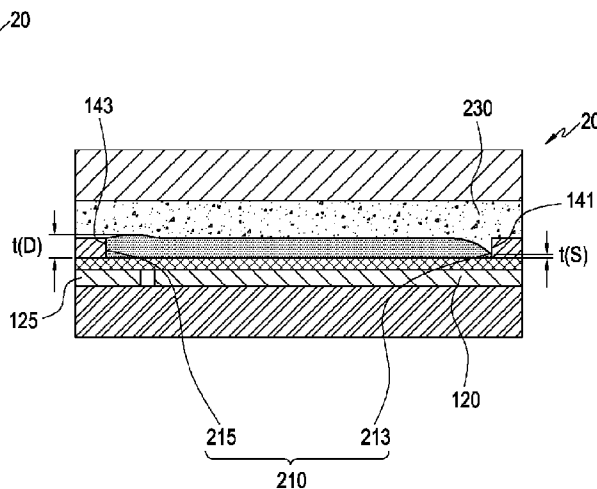
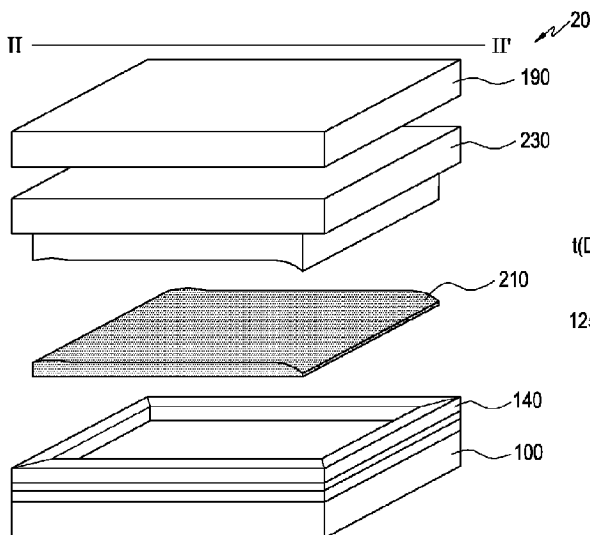

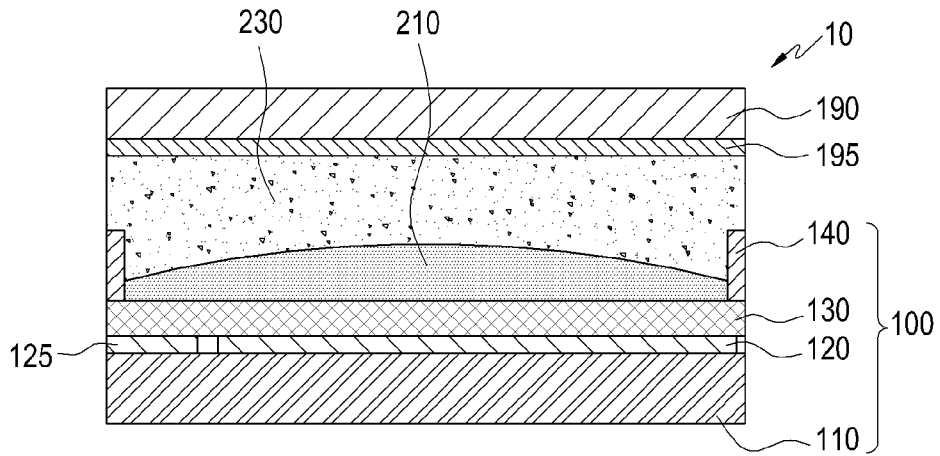

FIG. 1A
(RELATED ART)

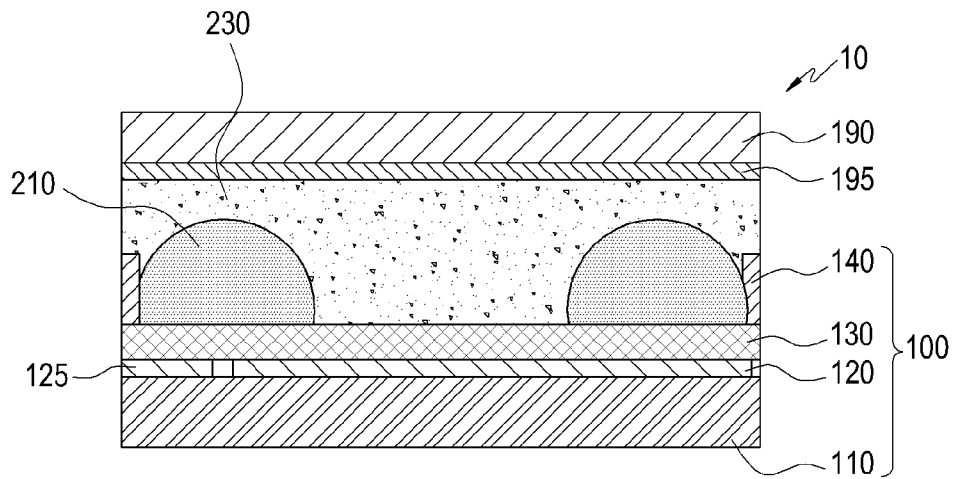

FIG. 1B
(RELATED ART)

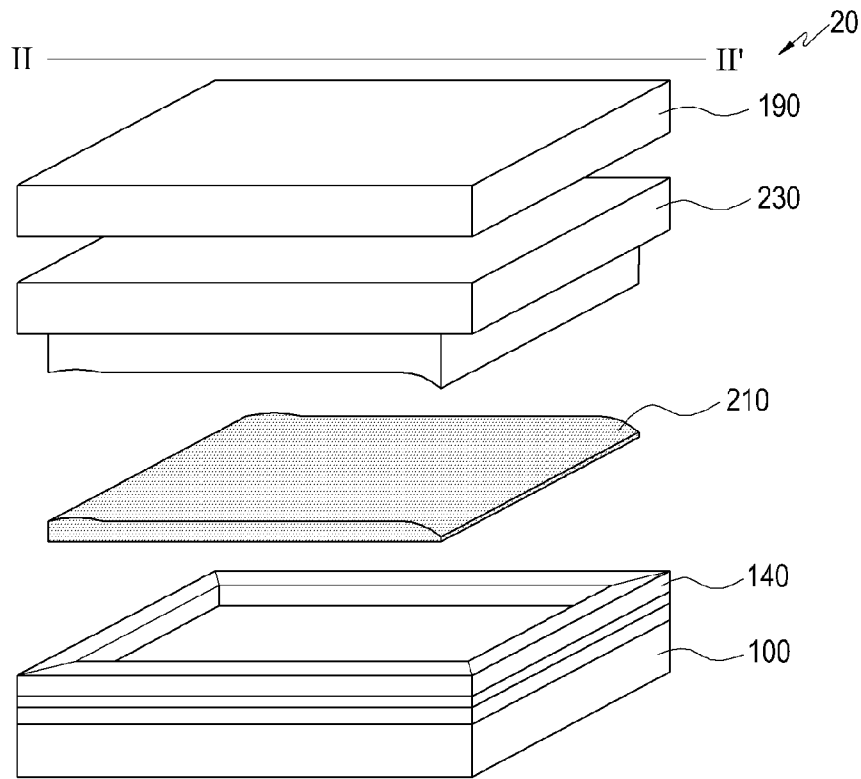

FIG. 2A

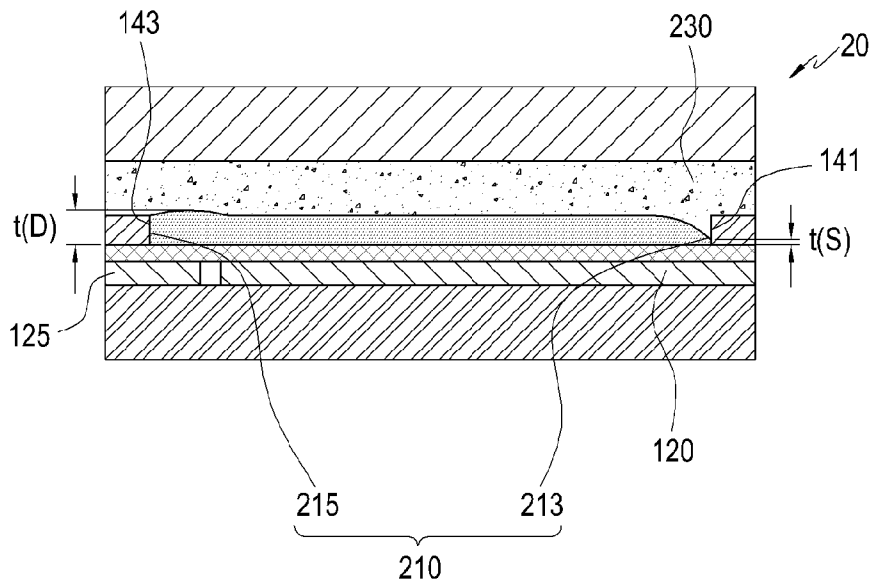
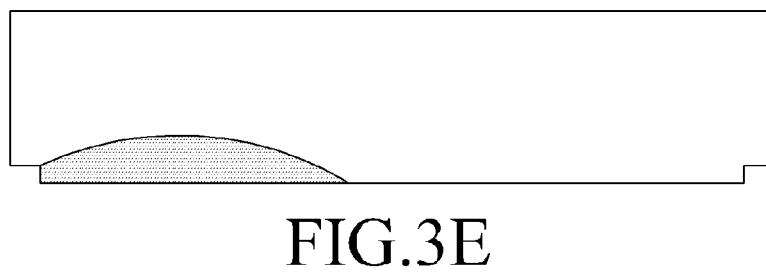
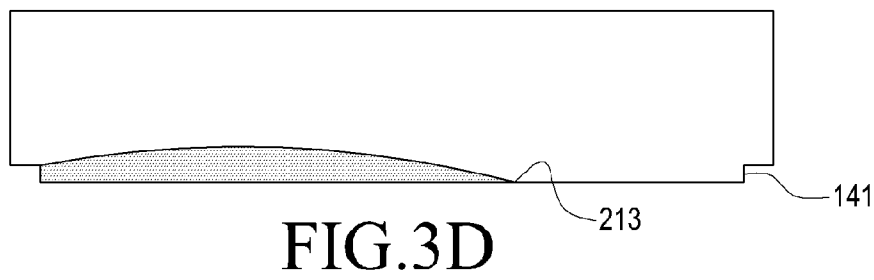
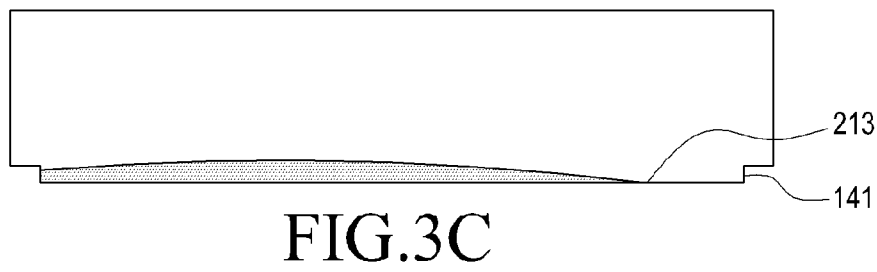
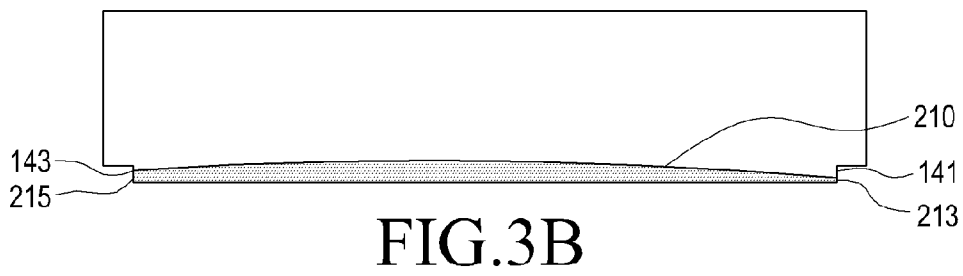
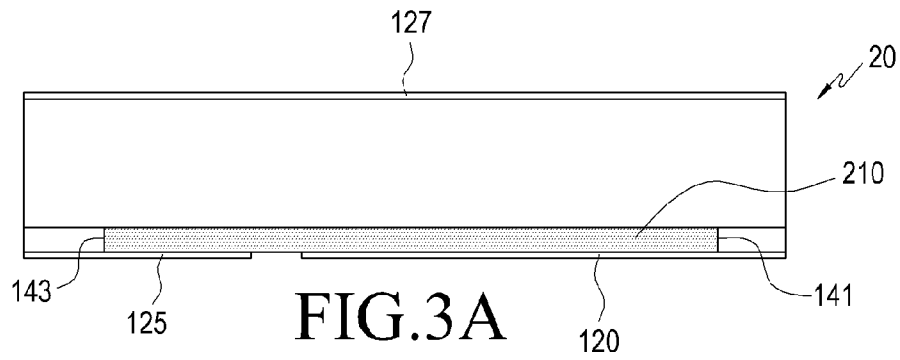

FIG. 2B



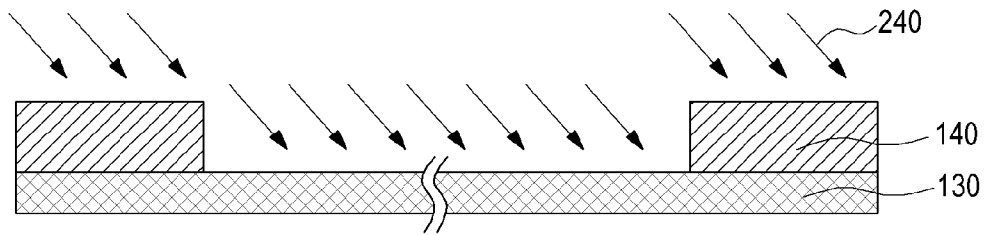

FIG.4A

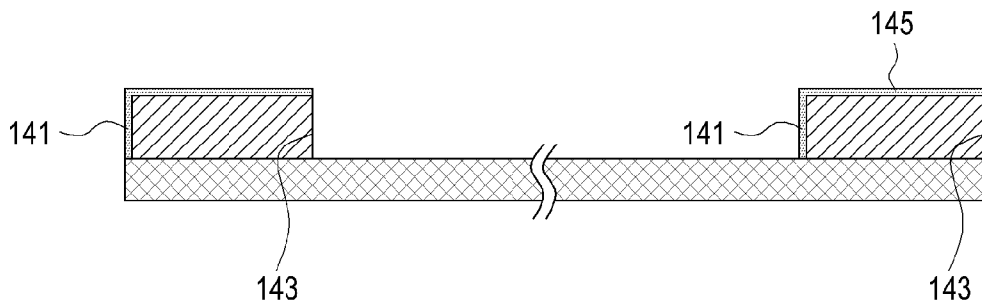

FIG.4B

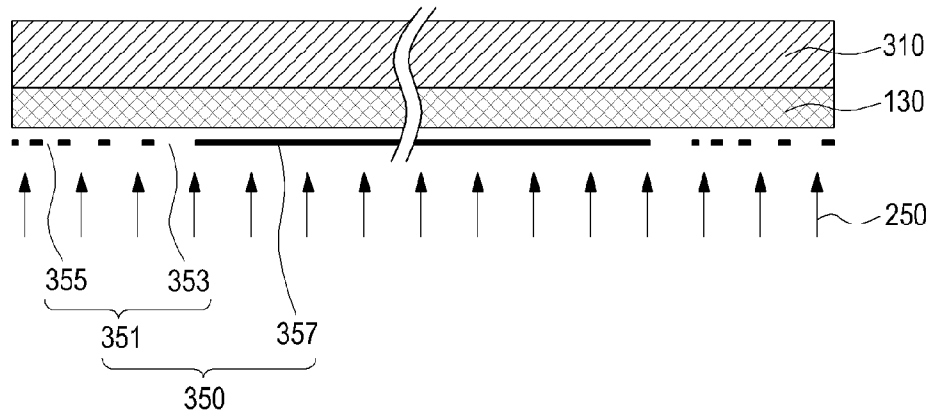

FIG.5A

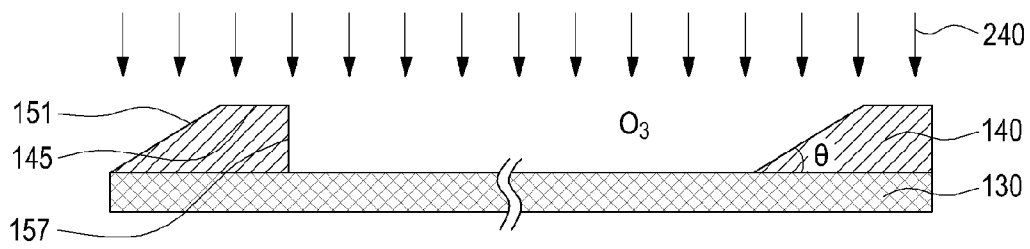

FIG.5B

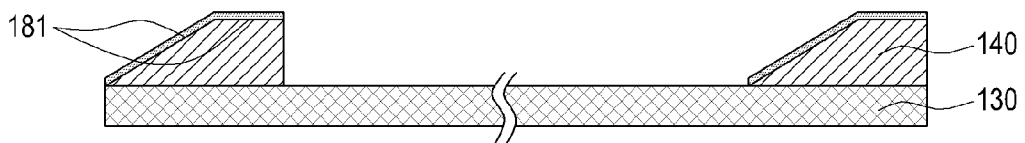

FIG.5C

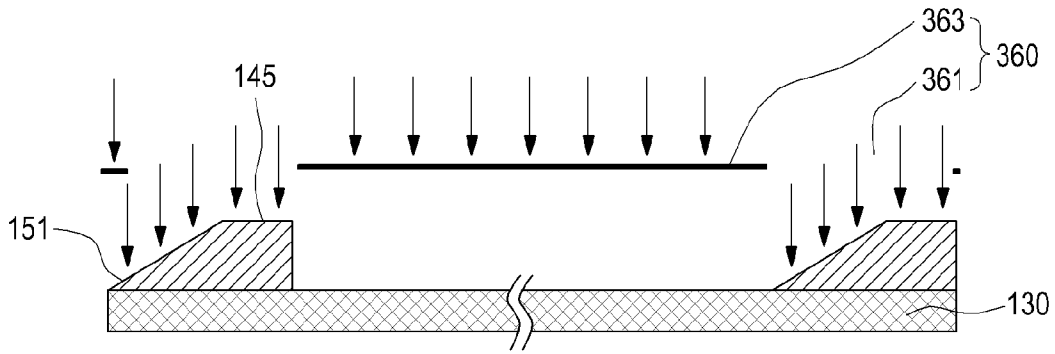

FIG. 6A

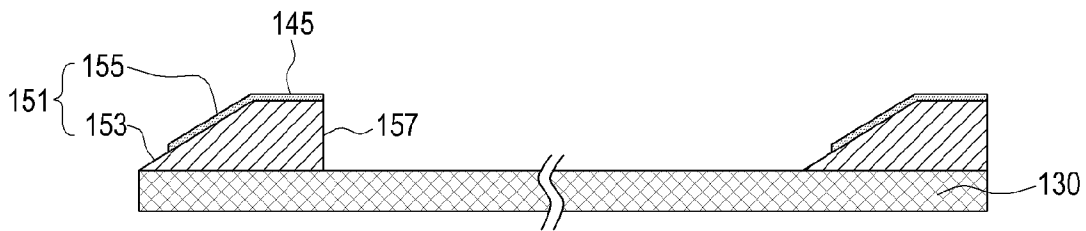

FIG. 6B

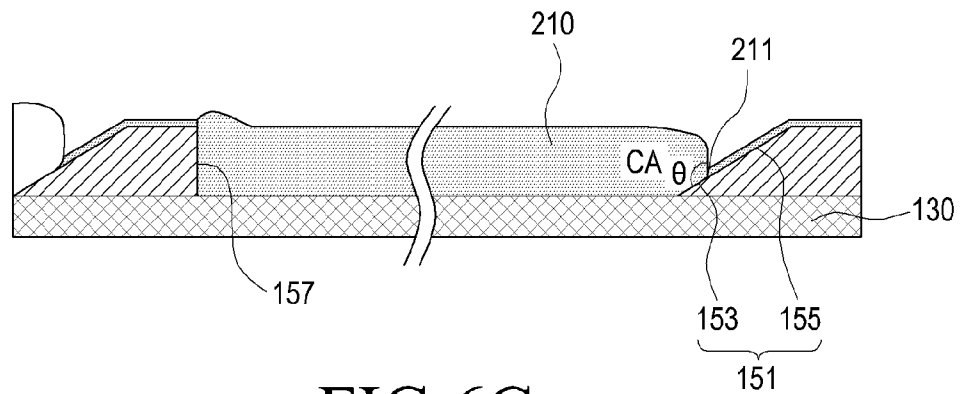

FIG. 6C

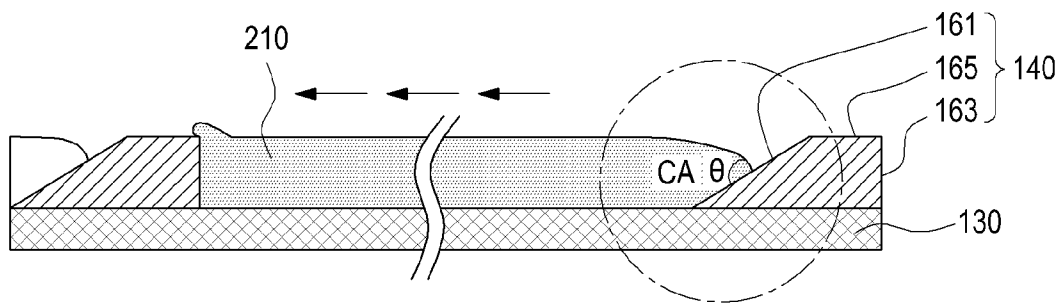

FIG. 7A

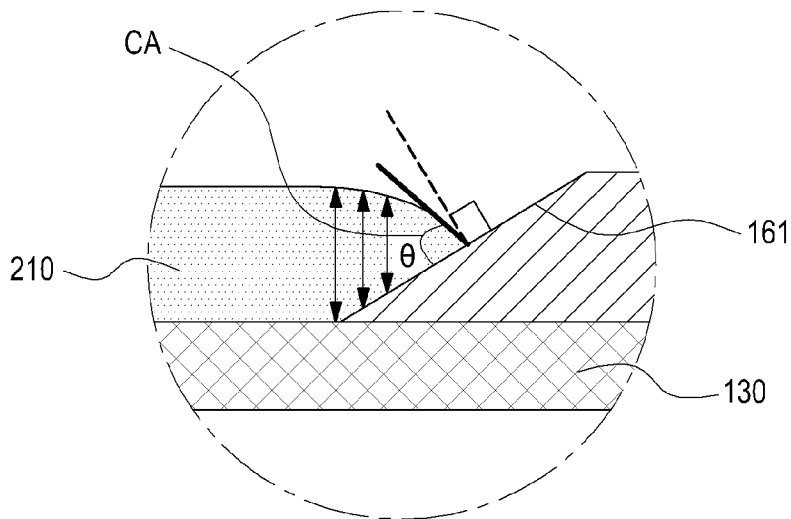

FIG. 7B

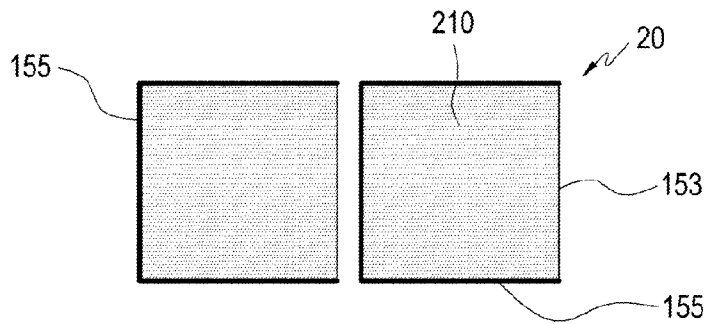

FIG. 8A

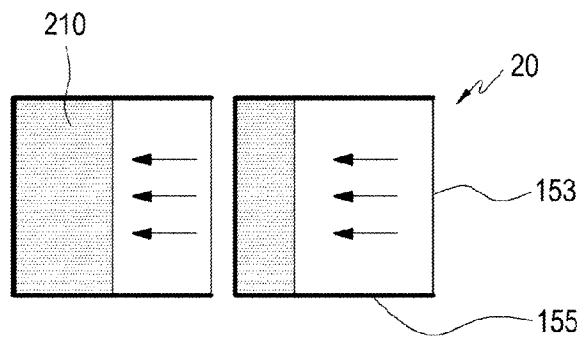

FIG. 8B

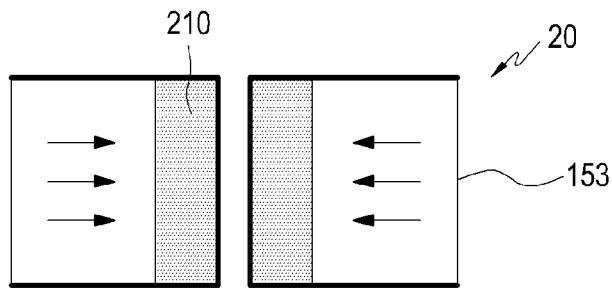

FIG. 9A

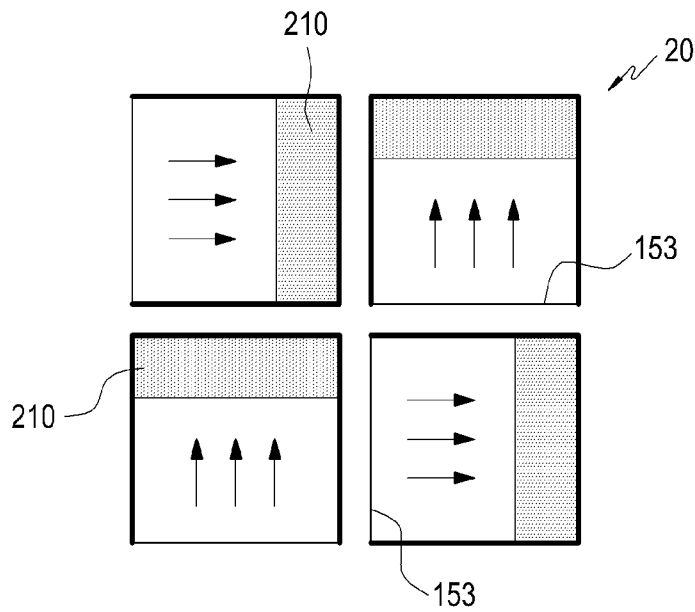

FIG. 9B

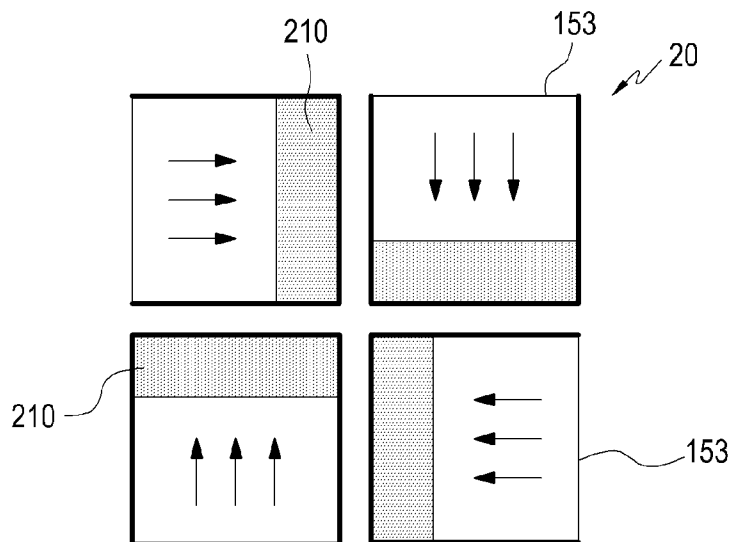
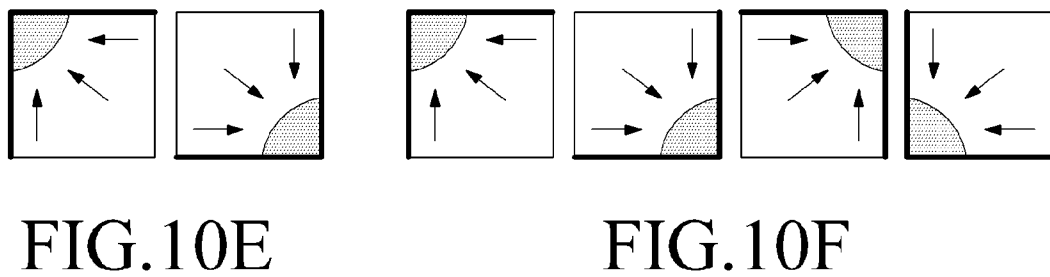
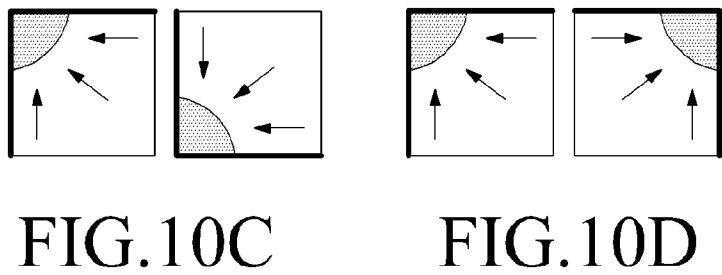
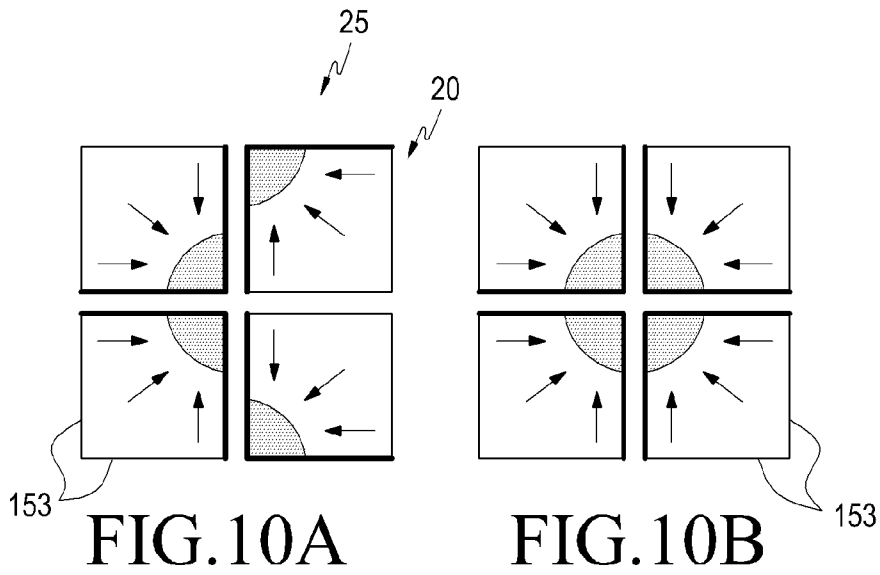

FIG. 9C



1

**ELECTROWETTING DISPLAY DEVICE
HAVING BANKS OF DIFFERENT
HYDROPHILICITIES AND METHOD FOR
MANUFACTURING THE SAME**

CROSS REFERENCE TO RELATED
APPLICATION

This application claims priority from and the benefit of Korean Patent Application No. 10-2011-0147311, filed on Dec. 30, 2011, which is hereby incorporated by reference for all purposes as if fully set forth herein.

BACKGROUND

1. Field

The present invention relates to an electrowetting display device and a method for manufacturing the same, and more particularly to an electrowetting display device having banks of different hydrophilicities/hydrophobicities and a method for manufacturing the same.

2. Discussion of the Background

An electrowetting effect refers to the change of contact angle between a conductive hydrophobic fluid and a hydrophobic layer positioned beneath the fluid, when a voltage is selectively applied to the fluid. Specifically, the smaller the voltage applied to the hydrophobic fluid is, the smaller the contact angle between the hydrophobic fluid and the hydrophobic layer becomes. The smaller the contact angle is, in turn, the larger the surface area of the hydrophobic fluid on the hydrophobic layer becomes.

An electrowetting display device is based on such an electrowetting effect. FIGS. 1A and 1B are sectional views of a pixel of a conventional electrowetting display device.

The electrowetting display device **10** includes a first substrate **100**, a hydrophobic fluid **210** positioned on the first substrate **100**, a hydrophilic fluid **230** positioned on the hydrophobic fluid **210** and which is immiscible with the hydrophobic fluid **210**, and a second substrate **190** positioned over the hydrophilic fluid **230**.

The first substrate **100** includes a first basic substrate **110**, a first pixel electrode **120** formed on the first basic substrate **110**, and a hydrophobic layer **130** formed on the pixel electrode **120**. Banks **140** are formed on parts of the hydrophobic layer **130** to limit the movement of the hydrophobic fluid **210**. The hydrophobic fluid **210** includes a pigment of a predetermined color. When the pixel electrode **120** is provided with no voltage, the hydrophobic fluid **210** is distributed over the entire hydrophobic layer **130**, as shown in FIG. 1A, and the pixel displays the color of the pigment. The hydrophilic fluid **230** is transparent and is arranged on the hydrophobic fluid **210**.

In order for the display device **10** to display a predetermined image, voltages of a predetermined gradation level are applied to the pixel electrode **120** of each pixel. When a voltage is applied to the pixel electrode **120**, as shown in FIG. 1B, a part of the hydrophobic fluid **210** at the center of the layer is broken up, and then the hydrophobic fluid **210** moves towards the banks **140** positioned on edges of the pixel electrode. In order to guarantee that the breakup occurs at a constant position, the pixel further includes an auxiliary electrode **125** positioned separate from the pixel electrode **120** and provided with a voltage different from the pixel electrode **120**. However, even the existence of the auxiliary electrode **125** cannot guarantee that the hydrophobic fluid **210** consistently brakes up.

2

Such breakup of the hydrophobic fluid **210** requires that a high voltage (e.g. 30 volts) be applied to the pixel electrode. However, high-voltage driving of the display device increases its power consumption, and the resulting electrolysis of fluids creates bubbles of oxygen or hydrogen gas as impurities inside the display device, degrading the display quality.

A satisfactory level of image display quality may require that the hydrophobic fluid of each pixel be distributed in the same position and area with regard to a predetermined gradation level. However, the inconsistency of the initial breakup position of the hydrophobic fluid makes it difficult to adjust the position and area of the hydrophobic fluid. Furthermore, the position and area of the hydrophobic fluid change, even if the pixel voltage is the same, during splitting and reunion of the hydrophobic fluid (hysteresis phenomenon), making it difficult to determine a voltage level with regard to a predetermined gradation level. Therefore, there is a need to design a display device in such a manner that fluids can also be driven at a low voltage, no unwanted gas is produced, and the fluids have the same position and area at a predetermined gradation level, as well as a method for manufacturing the same.

BRIEF SUMMARY OF THE INVENTION

Exemplary embodiments of the present invention provide an electrowetting display device that can be driven at a low voltage.

Further, exemplary embodiments of the present invention provide an electrowetting display device having fewer impurities.

Further, exemplary embodiments of the present invention provide an electrowetting display device configured to enable prediction and adjustment of the movement of hydrophobic and hydrophilic fluids.

Further, exemplary embodiments of the present invention provide a method for manufacturing an electrowetting display device having excellent display quality.

Exemplary embodiments of the present invention provide an electrowetting display device including a unit pixel that has banks of different hydrophilicities/hydrophobicities.

Additional features of the invention will be set forth in the description which follows, and in part will be apparent from the description, or may be learned by practice of the invention.

In accordance with an aspect of the present invention, there is provided an electrowetting display device comprising: a first substrate; a second substrate facing the first substrate; and pixels formed between the first and second substrates. Each pixel comprises: a pixel electrode disposed on the first substrate; a hydrophobic layer disposed on the pixel electrode; a hydrophobic fluid disposed on the hydrophobic layer; a bank disposed on the hydrophobic layer and surrounding the hydrophobic fluid, the bank comprising first and second bank surfaces that face the hydrophobic fluid, and hydrophilicity of the first bank surface is different from hydrophilicity of the second bank surface; and a hydrophilic fluid disposed on the hydrophobic fluid. The pixel electrode is configured to form an electric field and thereby move the hydrophobic fluid with respect to the first and second bank surfaces.

In accordance with another aspect of the present invention, there is provided a method of manufacturing an electrowetting display device, the method including: forming a pixel electrode on a first substrate; forming a hydrophobic layer on the pixel electrode; forming a bank on the hydrophobic layer, the bank having a first bank surface, a second bank surface, and an upper bank surface; and radiating UV rays onto the bank at an oblique angle with respect to the plane of the

hydrophobic layer, in an oxygen-containing atmosphere, to increase the hydrophilicity of portions of the bank.

In accordance with another aspect of the present invention, there is provided a method of manufacturing an electrowetting display device, the method including: forming a pixel electrode on a first substrate; forming a hydrophobic layer on the pixel electrode; radiating light through an exposure mask disposed below the first substrate, to expose a portion of the negative photoresist; etching the un-exposed portion of the negative photoresist to form a bank having a first bank surface, a second bank surface, and an upper bank surface; and radiating UV rays onto the bank from above the first substrate, to increase hydrophilicity of the first bank surface, or the upper bank surface, or both the upper and first bank surfaces.

In accordance with another aspect of the present invention, there is provided a method of manufacturing an electrowetting display device, the method including: forming a pixel electrode on a first substrate; forming a hydrophobic layer on the pixel electrode; forming a bank on the hydrophobic layer, the bank having a first bank surface that extends at an oblique angle with respect to the plane of the first substrate, a second bank surface, and an upper surface; and radiating the bank with UV rays using a hydrophilicity modification mask having an opening and a light shield.

In accordance with another aspect of the present invention, there is provided an electrowetting display device comprising: a first substrate; a second substrate facing the first substrate; and pixels formed between the first and second substrates. Each pixel comprises: a pixel electrode disposed on the first substrate; a hydrophobic layer disposed on the pixel electrode; a hydrophobic fluid disposed on the hydrophobic layer; a bank disposed on the hydrophobic layer and surrounding the hydrophobic fluid, the bank comprising first and second bank surfaces that face the hydrophobic fluid, the first surface being hydrophilic and the second bank surface being hydrophobic; and a hydrophilic fluid disposed on the hydrophobic fluid. The pixel electrode is configured to form an electric field that causes the hydrophobic fluid to move towards the second bank surface.

It is to be understood that both the foregoing general description and the following detailed description are exemplary and explanatory and are intended to provide further explanation of the invention as claimed.

BRIEF DESCRIPTION OF THE DRAWINGS

The accompanying drawings, which are included to provide a further understanding of the invention and are incorporated in and constitute a part of this specification, illustrate exemplary embodiments of the invention, and together with the description serve to explain the principles of the invention.

FIGS. 1A and 1B are magnified sectional views of a schematic pixel of an electrowetting display device, according to an exemplary embodiment of the present invention.

FIGS. 2A and 2B are a schematic exploded perspective view and a sectional view magnifying a pixel including a hydrophobic fluid, which has a different thickness according to the position, according to an embodiment of the present invention.

FIGS. 3A, 3B, 3C, 3D and 3E are sectional views of pixels illustrating the distribution of hydrophilic and hydrophobic fluids of pixels when different pixel voltages are applied.

FIGS. 4A and 4B are sectional views illustrating a process of modifying the surface characteristics of a bank.

FIGS. 5A, 5B, and 5C are sectional views illustrating a process of manufacturing bank surfaces having different extension directions and surface characteristics.

FIGS. 6A and 6B are sectional views illustrating a process of modifying the surface characteristics of a bank.

FIG. 6C is a sectional view illustrating the pixel of FIG. 6B when filled with a hydrophobic fluid.

FIG. 7A is a schematic sectional view of a pixel illustrating a hydrophobic fluid near an oblique bank surface and near a vertical bank surface.

FIG. 7B magnifies part VII of FIG. 7A.

FIGS. 8A and 8B are schematic top views of pixels illustrating the movement of fluid included in two adjacent pixels.

FIGS. 9A, 9B, and 9C are schematic top views of pixel groups, illustrating hydrophilic banks of pixels arranged in different positions.

FIGS. 10A, 10B, 10C, 10D, 10E, and 10F are schematic top views of different pixel groups, illustrating hydrophilic bank surfaces arranged in various positions.

DETAILED DESCRIPTION OF THE ILLUSTRATED EMBODIMENTS

The invention is described more fully hereinafter with reference to the accompanying drawings, in which exemplary embodiments of the invention are shown. This invention may, however, be embodied in many different forms and should not be construed as limited to the exemplary embodiments set forth herein. Rather, these exemplary embodiments are provided so that this disclosure is thorough, and will fully convey the scope of the invention to those skilled in the art. In the drawings, the size and relative sizes of layers and regions may be exaggerated for clarity. Like reference numerals in the drawings denote like elements.

It will be understood that when an element or layer is referred to as being "on" or "connected to" another element or layer, it can be directly on or directly connected to the other element or layer, or intervening elements or layers may be present. In contrast, when an element is referred to as being "directly on" or "directly connected to" another element or layer, there are no intervening elements or layers present.

According to various embodiments, bank surfaces included in a unit pixel of an electrowetting display device are arranged towards hydrophobic fluids and have different hydrophilicities. A hydrophobic fluid, when a pixel electrode is provided with a voltage, moves from a bank surface that is relatively more hydrophilic, towards a bank surface that is relatively more hydrophobic. The thickness of an edge of the hydrophobic fluid adjacent to the hydrophilic bank surface is smaller than that of the other edge. When the pixel electrode is provided with a voltage, the hydrophobic fluid moves from the thinner edge towards the thicker edge.

The hydrophilic bank can be formed by supplying energy and oxygen at an oblique angle to a hydrophobic bank. Alternatively, the hydrophilic bank can be formed using a material different from that of the hydrophobic bank. The hydrophobic fluid moves from the edge of its layer and thus, can be moved by an electric field produced by a low voltage. In addition, during its contraction and expansion, the path of movement is substantially constant, thereby reducing a hysteresis phenomenon.

FIGS. 2A and 2B are a schematic exploded perspective view and a sectional view illustrating a pixel 20 of an electrowetting display device, according to an exemplary embodiment of the present invention. While only one pixel 20 is shown, the display device may include a plurality of the pixels 20.

5

Referring to FIGS. 2A and 2B, the pixel 20 includes first and second substrates 100 and 190, a pixel electrode 120 and an auxiliary electrode 125 disposed on the first substrate 100, a hydrophobic layer 130 disposed on the pixel electrode 120 and the auxiliary electrode 125, and a bank 140 disposed on the hydrophobic layer 130. A hydrophobic fluid 210 and a polar hydrophilic fluid 230 disposed between the first and second substrates 100 and 190. The bank 140 includes opposing first and second bank surfaces 141 and 143, which are lateral surfaces facing the inside of the pixel 20. The hydrophobic fluid 210 has a first edge 213 that contacts the first bank surface 141 and has a thickness of t(S), and a second edge 215 that contacts the second bank surface 143 and has a thickness of t(D).

The thickness t(S) of the first edge 213 is smaller than the thickness t(D) of the second edge 215, and is larger than 0. When a voltage is applied to the pixel electrode 120 from outside the pixel 20, the hydrophobic fluid 210 moves from the thin first edge 213 towards the thick second edge 215. As the hydrophobic fluid 210 moves, the polar hydrophilic fluid 230 moves into the space vacated by the hydrophobic fluid 210. The variations in the thickness of the hydrophobic fluid 210 can be obtained by modifying the physical properties of the bank 140 or the shape of the bank 140.

FIGS. 3A-3E are simplified sectional views of the pixel 20, which illustrate the movement of hydrophilic and hydrophobic fluids according to the level of a voltage applied to the pixel electrode 120.

Referring to FIGS. 2B and 3A-3E, the pixel electrode 120 and the auxiliary electrode 125 are arranged beneath the hydrophobic fluid 210, and a common electrode 127 is arranged on the hydrophilic fluid 230. The common electrode 127 is disposed on the second substrate 190. The auxiliary electrode 125 is provided with a voltage of the same level as that applied to the common electrode 127, and the pixel electrode 120 is provided with a variable voltage, which is interlinked with the transmittance value of an image to be displayed by the pixel 20. According to various embodiments, the first and second bank surfaces 141 and 143 have different hydrophilicities. The higher the hydrophilicity of a bank surface, the larger the angle between the hydrophobic fluid and the bank surface, i.e., a contact angle (CA), becomes. Further, the lower the hydrophilicity (the higher the hydrophobicity) of the bank surface, the smaller the contact angle. It is to be noted that the simulation of FIGS. 3A-3E is based on conditions enumerated in Table 1 below.

TABLE 1

Pixel size	160 μm \times 160 μm
Pixel electrode width	108 μm
Auxiliary electrode width	33 μm
Interval between pixel and auxiliary electrodes	7 μm
Voltage of common electrode	30 volts
Voltage of auxiliary electrode	30 volts
Voltage of pixel electrode	0-30 volts
Cell gap	44 μm
Hydrophobic fluid	Decane
Hydrophilic fluid	Solution of mixture of ethylene glycol and glycerin at 2:1 weight ratio
Width of first and second banks	12 μm
Height of first and second banks	4 μm
Contact angle of first and second bank upper surfaces	170°
Contact angle of first bank surface	110°
Contact angle of second bank surface	90°

6

FIGS. 3A-3D illustrate the position of the hydrophobic fluid 210, when the pixel electrode 120 is applied with a pixel voltage of 0 volt, 10 volts, 20 volts, and 30 volts, respectively. Referring to FIG. 3B, the first edge 213 of the hydrophobic fluid 210 contacts a part of the first bank surface 141, and the second edge 215 contacts the entire second bank surface 143. Therefore, the first edge 213 of the hydrophobic fluid 210 is thinner than the second edge 215. Referring to FIGS. 3B-3D, the first edge 213 of the hydrophobic fluid 210 retreats from the first bank surface 141, according to the level of the pixel voltage applied to the pixel electrode (see, FIG. 2B).

As can be seen, the hydrophobic fluid 210 retreats from the first bank surface 141 to the second bank surface 143. The bank surface 141 may be made hydrophilic by irradiating the bank surface 141 with UV rays, in an ozone atmosphere.

FIGS. 4A and 4B are sectional views illustrating a process making portions of the bank 140 hydrophilic. It is to be noted that, for clarity of description, various elements (e.g. electrodes) have been omitted in the drawings. The bank 140 in FIG. 4A is formed by applying a negative photoresist, such as SU-8, to the hydrophobic layer 130, selectively irradiating only portions that are to form the bank 140, and etching the negative photoresist so that unexposed portions are removed. The above-mentioned method can form the bank 140 approximately perpendicular to the direction of extension of the hydrophobic layer 130.

The bank 140 is irradiated with UV rays 240 in an ozone atmosphere. For example, in the case of SU-8 molecules shown in Formula (1) below, their epoxy group is broken by ozone, and the resulting increase in polarity increases the hydrophilicity.

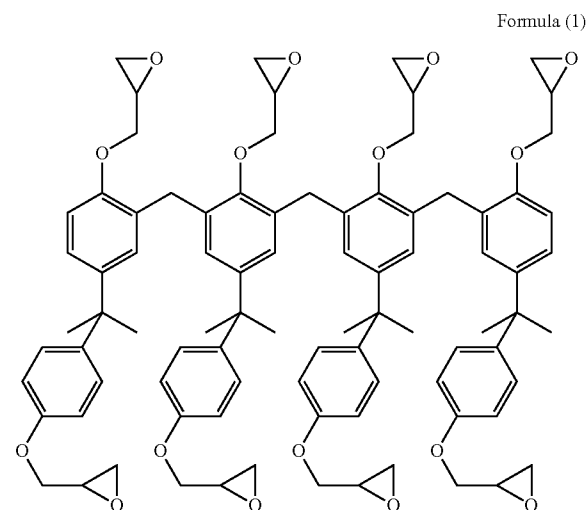

UV rays can be radiated at an oblique angle to the hydrophobic layer 130, in order to make portions of the bank 140 hydrophilic. In the case of a bank 140 made of SU-8, for example, UV rays having wavelengths of 185 nm and 254 nm can be radiated at an oblique angle to the bank 140. UV rays of 185 nm decompose oxygen molecules in the air and generate oxygen radicals, which combine with other oxygen molecules and become ozone radicals. The ozone or oxygen radicals, in conjunction with UV-rays of 254 nm, break the epoxy bonds of the SU-8, thereby increasing the polarity of SU-8 molecules. The SU-8 can thus be made hydrophilic.

Oblique radiation of UV rays 240 to the bank 140 increases the hydrophilicity of an upper surface 145 of the bank 140 and

the first bank surface **141**, which are irradiated with UV rays **240**. However, the second bank surface **143** is not irradiated with UV rays and remains highly hydrophobic. The resulting bank **140**, as shown in FIG. 4B, has a hydrophilic first bank surface **141** and a hydrophobic second bank surface **143**.

FIGS. 5A-5C are sectional views illustrating a processes of manufacturing a bank having different orientations, according to various embodiments. It is to be noted that, for clarity of description, some components are omitted in the drawings. Referring to FIG. 5A, a negative photoresist **310** is applied to a hydrophobic layer **130**. An exposure mask **350** having various sizes of openings **351** is arranged beneath the hydrophobic layer **130**. Light **250** is radiated through the openings **351** of the exposure mask **350** to expose the negative photoresist **310**, which may be SU-8, for example.

The exposure mask **350** includes a light shield **357**, through-holes **353**, and slit openings **355**. The light shield **357** prevents light from reaching a corresponding area of the photoresist **310**. The through-holes **353** allow a first amount of light to reach corresponding areas of the photoresist **310**. The slit openings **355** allow a limited amount of light to reach corresponding areas of the photoresist **310**, and the widths of the slit openings **355** can vary gradually, as shown in FIG. 5A, such that the largest slit opening **355** is disposed adjacent to the through-hole **353**. In other words, the slit openings **355** convert received light into a light gradient.

The exposure process shown in FIG. 5A, when completed, forms a vertical bank surface **157** extending perpendicular to the hydrophobic layer **130**, an oblique bank surface **151** extending at an oblique angle to the hydrophobic layer **130**, and a bank upper surface **145** arranged between the vertical bank surface **157** and the oblique bank surface **151**, as shown in FIG. 5B. In order to endow the bank surfaces **145**, **151**, and **157** with different surface characteristics, the method of irradiating the bank **140** with UV rays **240** in an ozone (O_3) atmosphere, as described with reference to FIG. 4A, may be employed. Considering that the hydrophilicity/hydrophobicity of the bank surfaces **145**, **151**, and **157** depends on the direction of radiation of UV rays **240**, in order to increase the hydrophilicity of the oblique bank surface **151**, UV rays **240** can be radiated between the angle θ , which is formed between the oblique bank surface **151** and the surface of the hydrophobic layer **130**.

Those skilled in the art can understand that, although not shown in the drawings, UV rays **240** can be alternatively radiated between the direction of extension of the hydrophobic layer from the point of view of the vertical bank surface **157** and the angle θ , which is defined between the oblique bank surface **151** and the hydrophobic layer **130**, in order to increase the hydrophilicity (decrease the hydrophobicity) of the vertical bank surface **157** and the bank upper surface **145**, without changing the surface characteristics of the oblique bank surface **151**.

FIG. 5B illustrates radiation of UV rays **240** to the bank **140** in a direction perpendicular to the surface of the hydrophobic layer **130**. This results in an increase of the polarity of molecular structure of the oblique bank surface **151** and the bank upper surface **145**, which become hydrophilic layers **181** shown in FIG. 5C.

A process of turning the entire oblique bank surface **151** into a highly hydrophilic bank surface **181** has been described, but it is also possible to make only a portion of the oblique bank surface **151** hydrophilic, while the remaining portion remains hydrophobic. FIGS. 6A and 6B are sectional views illustrating a process of changing the surface characteristics of a bank. FIG. 6A illustrates a hydrophilicity modification mask **360**, which is adapted to irradiate parts of an

oblique bank surface **151** with UV rays **240** radiated from above the mask. The hydrophilicity modification mask **360** has openings **361** and a light shield **363**. The openings **361** face a portion of the mask **360** that corresponds to a portion of the oblique bank surface **151**, and a portion of the mask **360** that corresponds to the bank upper surface **145**. The light shield **363** is disposed adjacent to the openings **361** are formed.

As shown in FIG. 6A, UV rays **240**, which are radiated from above the mask **360** in a direction perpendicular to the hydrophobic layer **130**, reach only a portion of the oblique bank surface **151**, increasing the hydrophilicity of the portion. Therefore, as shown in FIG. 6B, the oblique bank surface **151** includes a hydrophobic bank surface **153** and a hydrophilic bank surface **155**. It is to be noted that it is still possible to form, on a single oblique bank surface **151**, portions **153** and **155** having different surface characteristics, even when the light shield **363** is alternatively formed only on a portion of the mask corresponding to the hydrophilic portion **155** of the oblique bank surface **151**. It is also to be noted that the process of modifying hydrophilicity shown in FIG. 6A can be combined with the process of radiating UV rays in an ozone atmosphere described and illustrated in FIG. 4A.

Through a following fluid injection process, the pixel shown in FIG. 6B can be filled with a hydrophobic fluid **210**, as shown in FIG. 6C. Referring to FIG. 6C, the oblique bank surface **151** includes a hydrophilic bank surface **155** disposed above a hydrophobic bank surface **153**. The hydrophobic fluid **210**, can be distributed to cover the top of the hydrophobic layer **130** and the hydrophobic bank surface **153**, and such distribution of the hydrophobic fluid **210** can prevent degradation of contrast ratio of the display device, due to light leakage from the pixel.

The hydrophobic fluid **210** can have an edge positioned at the boundary between the hydrophobic bank surface **155** and the hydrophilic bank surface **153**. Alternatively, when there is a large amount of hydrophobic fluid **210**, the hydrophobic fluid can have an edge **211** positioned on the hydrophilic bank surface **155**. In either case, the edge **211** of the hydrophobic fluid has a contact angle CA larger than 90° , and its thickness is smaller than that of the other part of the hydrophobic fluid **210**. The hydrophobic fluid **210** thus has an asymmetric overall shape, i.e., is thicker at the hydrophobic vertical bank surface **157** and is thinner at the oblique bank surface **151**. Therefore, when a predetermined pixel voltage is applied to the pixel electrode (not shown) positioned beneath the hydrophobic layer **130**, the hydrophobic fluid can easily move from the oblique bank surface **151** towards the hydrophobic vertical bank surface **157**.

Although it has been described that different hydrophilicities of banks vary the thickness of the hydrophobic fluid according to position, the variation of thickness in a different position can also be obtained by the varying shape of the bank or the bank surface. FIG. 7A is a schematic sectional view of a pixel illustrating thickness differences of the hydrophobic fluid **210**. FIG. 7B illustrates part VII of FIG. 7A.

Referring to FIGS. 7A and 7B, the bank **140** has a hydrophobic oblique bank surface **161**, a hydrophobic vertical bank surface **163**, and a hydrophilic upper bank surface **165**. Referring to FIG. 7B, the contact angle CA between the hydrophobic fluid **210** and the hydrophobic oblique bank surface **161** is smaller than 90° , meaning that the thickness of the hydrophobic fluid **210** on the oblique bank surface **161** is less than that on the hydrophobic layer **130**. Therefore, application of a pixel voltage to the pixel electrode (not shown) arranged beneath the hydrophobic layer **130** can commence a movement of the hydrophobic fluid **210** from the oblique bank

surface **161** towards the vertical bank surface **163** of the adjacent bank. Those skilled in the art can understand that, although the vertical bank surface **163** is shown in FIGS. **7A** and **7B** as being perpendicular to the direction of extension of the hydrophobic layer **130**, the angle between the vertical bank surface **163** and the hydrophobic layer **130** is not limited thereto, as long as it is larger than the angle between the oblique bank surface **161** and the hydrophobic layer **130**.

According to various embodiments, the hydrophobic fluid included in pixels can move in a single direction or in different directions. FIGS. **8A** and **8B** are schematic top views of pixels illustrating the same direction of fluid movement in two adjacent pixels. Referring to FIG. **8A**, a lowest gamma level signal is applied to a pixel electrode (not shown) included in a pixel **20**, and the hydrophobic fluid **210** is accordingly distributed over the pixel **20**. Among bank surfaces formed in the method described and illustrated in FIGS. **4-7**, three bank surfaces within a pixel are hydrophobic bank surfaces **155**, and the remaining one bank surface is a hydrophilic bank surface **153**. As shown in FIG. **8A**, the hydrophilic bank surfaces **153** are positioned on the right side of respective pixels **20**. Therefore, the hydrophilic bank surfaces **153** can be manufactured through a simple process. For example, if the process of radiating UV rays obliquely illustrated in FIGS. **4A** and **4B** is employed, the hydrophilic bank surfaces **153** can be formed through only one oblique radiation process, making it possible to manufacture pixels for a reduced manufacturing time and/or at a low manufacturing cost.

Referring to FIG. **8B**, when pixel electrodes (not shown) are provided with signals of a predetermined gamma level, hydrophobic fluid **210** included in respective pixels **20** moves away from the hydrophilic bank surfaces **153**. Those skilled in the art can easily understand that, since pixel electrodes of respective pixels are provided with signals of different gamma levels in FIG. **8B**, the hydrophobic fluids have different distribution areas.

The hydrophilic bank surfaces **153** can be arranged in various positions of respective pixels, so that the hydrophobic fluids can move in different directions. FIGS. **9A-9C** are schematic top views of pixel groups, illustrating hydrophilic banks of pixels arranged in different positions. Referring to FIG. **9A**, adjacent pixels **20** have hydrophilic bank surfaces **153** arranged on the left or right side of the pixels **20**. When the display device is driven, pixel electrodes (not shown) are provided with predetermined gradation voltage levels, and the hydrophobic fluids **210** move away from the hydrophilic bank surfaces **153**, due to an electric field corresponding to each voltage level. It is to be noted that the directions of movement of the hydrophobic fluids **210** are marked by arrows in respective pixels.

The hydrophilic bank surfaces **153** are arranged in intersecting directions, so that the hydrophobic fluids **210** move to the right or left of the pixels **20**. If the pixels of FIG. **9A** are adapted to display the same gradation level of the same color, similar images can be observed from the right or left side of the display device.

The intersecting arrangement of hydrophobic bank surfaces can be obtained, when the oblique UV radiation method shown in FIG. **4** is employed, for example, by using a mask for forming the left bank surface and another mask for forming the right bank surface. Those skilled in the art can easily understand that hydrophilic bank surfaces can be arranged in intersecting positions, as shown in FIG. **9A**, also by radiating UV rays while moving a mask, or by radiating UV rays from opposite locations of the same mask.

In the case of a pixel group, which is a set of pixels displaying the same gradation of the same color, the hydropho-

bic fluid included in the pixels can be distributed in various positions, including the pixel's right portion, left portion, upper portion, and lower portion. Referring to FIG. **9B**, the hydrophilic bank surfaces **153** of the four pixels are arranged in intersecting directions, and the hydrophobic fluids **210** are also arranged in intersecting directions in conformity with the positions of the hydrophilic bank surfaces **153**. Therefore, substantially the same images can be viewed from the top/bottom/left/right of the display device. FIG. **9C** illustrates a group of pixels having hydrophobic fluids arranged in the shape of a pinwheel, and, as in the case of the pixel groups shown in FIG. **9B**, the uniformity of images viewed in different directions can be improved.

Although only one bank surface of a pixel of a pixel group is hydrophilic in the above-mentioned cases, it is also possible that two adjacent bank surfaces are hydrophilic. FIGS. **10A-10F** are schematic top views of different pixel groups, illustrating each pixel **20** having two adjacent hydrophilic bank surfaces **153**, which are arranged in various positions. The pixel group **25** can be a group of pixels representing the same color, when voltages of the same gradation level are applied to their respective pixel electrodes.

Referring to FIG. **10A**, the pixel group **25** has four adjacent pixels **20**, each of which has two adjacent hydrophilic bank surfaces **153**. When a voltage of a predetermined gradation level is applied to the pixel electrode (not shown), the hydrophobic fluids **210** move away from the hydrophilic bank surfaces **153**, and the hydrophobic fluids **210** in each pixel **20** are disposed in different relative locations. Therefore, the display device makes it possible to observe uniform images from different directions.

FIGS. **10b-10F** are schematic top views of pixel groups, illustrating hydrophilic bank surfaces distributed in various positions in corresponding pixels. Those skilled in the art can easily understand that hydrophobic fluids in respective pixels move in directions marked by arrows, and respective hydrophilic bank surfaces are made using one or a number of hydrophilicity modification masks, according to the method described and illustrated in FIG. **4**, for example.

The electrowetting display device having banks of different hydrophilicities according to the present invention is advantageous in that it has less impurities, it can be driven at a low voltage, and it has less hysteresis. Other advantages, which have been described in the detailed description, will be easily understood by those skilled in the art.

It will be apparent to those skilled in the art that various modifications and variation can be made in the present invention without departing from the spirit or scope of the invention. Thus, it is intended that the present invention cover the modifications and variations of this invention provided they come within the scope of the appended claims and their equivalents.

What is claimed is:

1. An electrowetting display device comprising:

- a first substrate;
- a second substrate facing the first substrate; and
- pixels formed between the first and second substrates, each pixel comprising:
 - a pixel electrode disposed on the first substrate;
 - a hydrophobic layer disposed on the pixel electrode;
 - a hydrophobic fluid disposed on the hydrophobic layer;
 - a bank disposed on the hydrophobic layer and surrounding the hydrophobic fluid, the bank comprising first and second bank surfaces that face the hydrophobic fluid, and hydrophilicity of the first bank surface is different from hydrophilicity of the second bank surface; and

11

a hydrophilic fluid disposed on the hydrophobic fluid, wherein the pixel electrode is configured to form an electric field to move the hydrophobic fluid with respect to the first and second bank surfaces.

2. The electrowetting display device as claimed in claim 1, wherein:

the first and second bank surfaces are disposed on opposing sides of the hydrophobic fluid; and the first bank surface comprise a hydrophobic portion.

3. The electrowetting display device as claimed in claim 2, wherein the thickness of an edge of the hydrophobic fluid facing the first bank surface is smaller than the thickness of an edge of the hydrophobic fluid facing the second bank surface.

4. The electrowetting display device as claimed in claim 3, wherein, when no voltage is applied to the pixel electrode, the hydrophobic fluid contacts the first and second bank surfaces.

5. The electrowetting display device as claimed in claim 4, wherein the contact angle between the hydrophobic fluid and the first bank surface is smaller than the contact angle between the hydrophobic fluid and the second bank surface.

6. The electrowetting display device as claimed in claim 5, wherein the contact angle between the hydrophobic fluid and the first bank surface is smaller than 90°.

7. The electrowetting display device as claimed in claim 2, wherein the hydrophobic fluid is moved from the first bank surface towards the second bank surface by the electric field.

8. The electrowetting display device as claimed in claim 1, wherein the first and second bank surfaces are disposed on opposing sides of the bank, and the first bank surface extends at an oblique angle with respect to the plane of the hydrophobic layer.

9. The electrowetting display device as claimed in claim 8, wherein a portion of the first bank surface is hydrophobic.

10. The electrowetting display device as claimed in claim 8, wherein the first bank surface comprises the hydrophilic portion and a hydrophobic portion, and the hydrophobic portion is disposed closer to the first substrate than the hydrophilic portion.

11. The electrowetting display device of claim 8, wherein the bank further comprises:

a lower surface disposed directly on the hydrophobic layer; and

an opposing upper surface that extends from the first bank surface and is hydrophilic.

12. The electrowetting display device of claim 11, wherein the first bank surface comprises:

a hydrophilic portion disposed adjacent to the upper surface; and

12

a hydrophobic portion disposed adjacent to the hydrophobic layer.

13. The electrowetting display device of claim 8, wherein: the bank comprises four sidewalls that surround the hydrophobic fluid;

the first bank surface is disposed on a first one of the sidewalls; and

the second bank surface is disposed on second, third, fourth ones of the sidewalls.

14. The electrowetting display device of claim 8, wherein: the bank comprises four sidewalls that surround the hydrophobic fluid;

the first bank surface is disposed on two adjacent ones of the sidewalls; and

the second bank surface is disposed on the remaining sidewalls.

15. The electrowetting display device of claim 8, wherein the first and second bank surfaces are both hydrophobic.

16. The electrowetting display device as claimed in claim 1, wherein:

the first and second bank surfaces are disposed on opposing sides of the hydrophobic fluid; and

the electric field is configured to move the hydrophobic fluid from the first bank surface towards the second bank surface.

17. The electrowetting display device as claimed in claim 16, wherein adjacent ones of the pixels are configured to move the hydrophobic fluid in different directions when a pixel voltage is applied to the pixel electrodes of the pixels.

18. The electrowetting display device as claimed in claim 16, wherein adjacent ones of the pixels are configured to display the same color and move the hydrophobic fluids in different directions, when a pixel voltage is applied to the pixel electrodes of the pixels.

19. The electrowetting display device as claimed in claim 1, wherein:

the bank has four sidewalls;

the first bank surface is disposed on two adjacent ones of the sidewalls;

the second bank surface is disposed on two other adjacent ones of the sidewalls; and

the hydrophobic fluid is moved from the first bank surface towards the second bank surface by the electric field.

20. The electrowetting display device as claimed in claim 19, wherein hydrophobic fluids of adjacent pixels are moved in different directions by the corresponding electric fields.

* * * * *