

(19) **DANMARK**

(10) **DK/EP 3346629 T3**



(12) **Oversættelse af  
europæisk patentskrift**

Patent- og  
Varemærkestyrelsen

- 
- (51) Int.Cl.: **H 04 L 5/00 (2006.01)**
- (45) Oversættelsen bekendtgjort den: **2025-02-03**
- (80) Dato for Den Europæiske Patentmyndigheds bekendtgørelse om meddelelse af patentet: **2024-11-13**
- (86) Europæisk ansøgning nr.: **16840848.2**
- (86) Europæisk indleveringsdag: **2016-09-05**
- (87) Den europæiske ansøgnings publiceringsdag: **2018-07-11**
- (86) International ansøgning nr.: **CN2016098088**
- (87) Internationalt publikationsnr.: **WO2017036419**
- (30) Prioritet: **2015-09-06 CN 201510561005**
- (84) Designerede stater: **AL AT BE BG CH CY CZ DE DK EE ES FI FR GB GR HR HU IE IS IT LI LT LU LV MC MK MT NL NO PL PT RO RS SE SI SK SM TR**
- (73) Patenthaver: **ZTE Corporation, ZTE Plaza, Keji Road South , Hi-Tech Industrial Park , Nanshan, Shenzhen, Guangdong 518057, Kina**
- (72) Opfinder: **HAN, Xianghui, c/o ZTE CORPORATION, ZTE Plaza, Keji Road South, Hi-Tech Industrial Park, Nanshan, Shenzhen, Guangdong 518057, Kina**  
**XIA, Shuqiang, c/o ZTE CORPORATION ZTE Plaza, Keji Road South, Hi-Tech Industrial Park, Nanshan, Shenzhen, Guangdong 518057, Kina**  
**DAI, Bo, c/o ZTE CORPORATION, ZTE Plaza, Keji Road South, Hi-Tech Industrial Park, Nanshan, Shenzhen, Guangdong 518057, Kina**  
**ZHANG, Wen, c/o ZTE CORPORATION ZTE Plaza, Keji Road South, Hi-Tech Industrial Park, Nanshan, Shenzhen, Guangdong 518057, Kina**  
**SHI, Jing, c/o ZTE CORPORATION ZTE Plaza, Keji Road South, Hi-Tech Industrial Park, Nanshan, Shenzhen, Guangdong 518057, Kina**  
**DAI, Qian, c/o ZTE CORPORATION ZTE Plaza, Keji Road South, Hi-Tech Industrial Park, Nanshan, Shenzhen, Guangdong 518057, Kina**  
**GOU, Wei, c/o ZTE CORPORATION, ZTE Plaza, Keji Road South, Hi-Tech Industrial Park, Nanshan, Shenzhen, Guangdong 518057, Kina**
- (74) Fuldmægtig i Danmark: **NORDIC PATENT SERVICE A/S, Bredgade 30, 1260 København K, Danmark**
- (54) Benævnelse: **FREMGANGSMÅDE OG ENHED TIL OVERFØRSEL AF INFORMATIONER**
- (56) Fremdragne publikationer:  
**EP-A2- 2 600 581**  
**EP-A2- 2 605 442**  
**CN-A- 101 826 948**  
**CN-A- 102 064 921**  
**CN-A- 102 710 397**

Fortsættes ...

**CN-A- 103 973 397**

**US-A1- 2011 080 880**

**US-A1- 2014 233 506**

**US-B2- 8 885 743**

**NTT DOCOMO ET AL: "sPUCCH for shortened TTI", vol. RAN WG1, no. Nanjing; 20160523 - 20160527, 14 May 2016 (2016-05-14), XP051096208, Retrieved from the Internet**

**<URL:[http://www.3gpp.org/ftp/tsg\\_ran/WG1\\_RL1/TSGR1\\_85/Docs/](http://www.3gpp.org/ftp/tsg_ran/WG1_RL1/TSGR1_85/Docs/)> [retrieved on 20160514]**

**TEXAS INSTRUMENTS: "ACK/NAK Transmission without Reference Signal Overhead in E-UTRA Uplink", 3GPP DRAFT; R1-070275\_ACK\_NAK, 3RD GENERATION PARTNERSHIP PROJECT (3GPP), MOBILE COMPETENCE CENTRE ; 650, ROUTE DES LUCIOLES ; F-06921 SOPHIA-ANTIPOLIS CEDEX ; FRANCE, vol. RAN WG1, no. Sorrento, Italy; 20070110, 10 January 2007 (2007-01-10), XP050104310**

# DESCRIPTION

Description

## TECHNICAL FIELD

**[0001]** The disclosure relates to, but not limited to a wireless communication technology, and in particular to a method and device for transmitting information.

## BACKGROUND

**[0002]** The rapid development of the mobile internet and the internet of things trigger explosive increase of data traffic and extensive appearance of diversified and differentiated services. The fifth generation mobile communication technology (5G), serving as a new generation mobile communication technology, will support a higher rate, a huge number of links, an ultralow delay, higher reliability, hundredfold increase of energy efficiency and the like so as to support requirement changes. The ultralow delay, serving as a key index of the 5G technology, directly affects development of delay-limited services such as car networking, industrial automation, remote control and smart grids. A current series of standard researches on 5G delay reduction is promoting gradually.

**[0003]** The reduction of a Transmission Time Interval (TTI), serving as an important research direction of delay reduction, aims to reduce the length of a current TTI of 1ms to 0.5ms or even 1 to 2 symbols, thereby shortening minimum scheduling time exponentially. Thus, a single transmission delay can be reduced exponentially without changing the frame structure.

**[0004]** However, when the length of the TTI is reduced to a length of 1 to 7 symbols, the transmission structure of a related Physical Uplink Control Channel (PUCCH) for sending an Acknowledgement (ACK) and a Negative Acknowledgement (NACK) cannot be directly used. Meanwhile, shortening of the TTI in time domain will affect the demodulation performance of transmitted information, and the related PUCCH is in shortage of frequency domain diversity due to occupancy of only one Physical Resource Block (PRB) in frequency domain. In addition, reduction of the number of symbols within the TTI will cause reduction of available resources for transmitting valid data due to excessive overheads of a Reference Symbol (RS).

**[0005]** TEXAS INSTRUMENTS "ACK/NAK Transmission without Reference Signal Overhead in E-UTRA Uplink" 3GPP DRAFT; R1-070275 (XP050104310) disclosed a non-coherent ACK/NAK transmission method using a cyclic shifted CAZAC sequence, where the amount of

cyclic shift of the CAZAC sequence carries ACK/NAK bits, and the ACK/NAK bits are one-to-one mapped on a cyclic shifted version of the base CAZAC sequence. Q

**[0006]** EP 2605442 A2 disclosed a method for supporting the transmission of SRS (sounding reference signals), in which a comb spectrum can be used for the transmission of a DMRS or SRS.

## **SUMMARY**

**[0007]** The invention is set out in the appended set of claims.

## **BRIEF DESCRIPTION OF DRAWINGS**

### **[0008]**

FIG. 1 is a flowchart of a method for transmitting information according to embodiments of the disclosure.

FIG. 2 is a structure diagram of a device for transmitting information according to embodiments of the disclosure.

FIG. 3 is an ACK/NACK transmission structure for a related TTI=1ms PUCCH Format 1/1a/1b with a conventional Cyclic Prefix (CP).

FIG. 4 is a sending diagram of K-bit ACK/NACK fed back in a PUCCH when a TTI occupies a single symbol length according to an embodiment of the disclosure.

FIG. 5 is a sending diagram of K-bit ACK/NACK fed back in a PUCCH when a TTI occupies a 7-symbol length according to an embodiment of the disclosure.

FIG. 6 is a sending diagram of K-bit ACK/NACK fed back in a PUCCH when a TTI occupies a 2-symbol length according to an embodiment of the disclosure.

FIG. 7 is a diagram of joint transmission of K-bit ACK/NACK fed back in a PUCCH and an SRS when a TTI occupies a single symbol length according to an embodiment of the disclosure, where the ACK/NACK and the SRS adopt the same sequence length.

FIG. 8 is a diagram of joint transmission of K-bit ACK/NACK fed back in a PUCCH and an SRS when a TTI occupies a single symbol length according to an embodiment of the disclosure, where the ACK/NACK and the SRS adopt different sequence lengths.

FIG. 9 is a sending example of joint transmission of full-bandwidth mapped ACK/NACK and an SRS when a TTI occupies a single symbol length according to an embodiment of the disclosure.

FIG. 10 is a sending diagram of 1-2bit ACK/NACK fed back in a PUCCH when a TTI occupies a 2-symbol length according to an embodiment of the disclosure.

FIG. 11 is a sending diagram of 1-2bit ACK/NACK fed back in a PUCCH when a TTI occupies a 7-symbol length according to an embodiment of the disclosure.

## DETAILED DESCRIPTION

**[0009]** The embodiments of the disclosure will be described below in conjunction with the drawings in detail. It is to be noted that the embodiments in the present application and the features in the embodiments may be randomly combined with each other without conflicts.

**[0010]** Steps shown in the flowchart of the drawings may be executed in a computer system including, for example, a set of computer-executable instructions. Moreover, although a logic sequence is shown in the flowchart, the shown or described steps may be executed in a sequence different from the sequence here under certain conditions.

**[0011]** The embodiments of the disclosure provide a method for transmitting information. As shown in FIG. 1, the method, based on a UE side, includes the steps as follows.

**[0012]** In step 101, a predefined pattern for carrying information is determined. The predefined pattern includes a predefined sequence or a predefined RS time frequency structure.

**[0013]** In step 102, the predefined pattern carrying the information is transmitted on a preset time-frequency domain resource.

**[0014]** The information includes ACK or NACK.

**[0015]** The predefined pattern comprises the predefined sequence, the preset time-frequency domain resource includes a preset time domain resource and a preset frequency domain resource; the preset time domain resource includes a TTI with a duration of  $K$  symbols, where  $K$  is greater than or equal to 1 and smaller than or equal to 7, and  $K$  is a positive integer; and the preset frequency domain resource includes  $M$  subcarriers, the  $M$  subcarriers being mapped as a comb structure in frequency domain, wherein a frequency domain offset number  $N$  is an integral multiple of 2, and  $M$  is an integral multiple of 12. Alternatively,  $M$  may be 48 or 72.

**[0016]** The frequency domain offset refers to an offset of an initial subcarrier index relative to a lowest index of a corresponding resource block when  $M$  subcarriers are mapped to a comb structure in frequency domain, and the frequency domain offset number is a total number of all possible offsets. For example, when a subcarrier is used as a mapping interval, namely when

one of every two subcarriers is mapped, the frequency domain offset number is 2, and the frequency domain offset is 0 or 1.

**[0017]** Alternatively, the predefined sequence has a length  $L$ , which is an integral multiple of 12, a basic sequence of the predefined sequence includes a QPSK-based sequence or a ZC sequence, and a sequence in the predefined sequence is obtained based on the basic sequence.

**[0018]** Alternatively, when  $L$  is greater than 24, the basic sequence of the predefined sequence is the ZC sequence.

**[0019]** Alternatively,  $L$  is 24 or 36.

**[0020]** When  $L$  is 24, the basic sequence of the predefined sequence is the QPSK-based sequence.

**[0021]** When  $L$  is 36, the basic sequence of the predefined sequence is the ZC sequence.

**[0022]** Alternatively, step 102 may include the sub-step as follows.

**[0023]** The predefined sequence is transmitted according to a first preset rule by using the  $M$  subcarriers at the TTI with the duration of  $K$  symbols.

**[0024]** Herein, the first preset rule includes:

for each of the  $K$  symbols, using a different basic sequence for a corresponding predefined sequence to be transmitted in the symbol; or,

for each of the  $K$  symbols, obtaining a corresponding predefined sequence to be transmitted in the symbol by performing a different cyclic shift on a same basic sequence.

**[0025]** Alternatively, the first preset rule further includes:

for each of the  $K$  symbols, using a different comb subcarrier offset of the  $M$  subcarriers; or,

for each of the  $K$  symbols, using a same frequency domain subcarrier position; or,

for the  $K$  symbols, using inter-symbol frequency hopping.

**[0026]** Alternatively, step 102 may include the sub-step as follows.

**[0027]** The predefined sequence is transmitted for each symbol of  $K$  symbols in the TTI in the

following manner: transmitting the predefined sequence by using the M subcarriers in a preset 1-symbol duration.

**[0028]** Alternatively, the preset time domain resource is a TTI having a 1-symbol length, and when a UE needs to send an SRS at frequency domain positions Y whilst needing to send the information at frequency domain positions X, step 102 may include the sub-step as follows.

**[0029]** The information is sent at frequency domain positions Y or a subset of Y within the TTI having a 1-symbol length.

**[0030]** Herein, one or more sequences transmitted at the frequency domain positions Y or the subset of Y and used for carrying the information are sequences used for transmitting the information at frequency domain positions X, or a repetition of sequences used for transmitting the information at frequency domain positions X, or truncation of sequences used for transmitting the information at frequency domain positions X, or punching of sequences used for transmitting the information at frequency domain positions X, or redefined sequences.

**[0031]** It is worth mentioning that in the related technical solution, when a UE needs to send ACK/NACK and SRSs simultaneously, an SRS is sent at a frequency domain position Q in the last symbol of a subframe, and an SRS is sent at a frequency domain position P in all other symbols of the subframe. Here, the frequency domain position P and the frequency domain position Q are not intersected. However, in the technical solution provided in the embodiments of the disclosure, a sequence for carrying ACK/NACK is sent at frequency domain positions Y or a subset of Y in the same symbol. Compared with the related technical solution, the present solution of the disclosure implements a scenario where ACK/NACK and SRSs are transmitted within the same symbol when a TTI is reduced to a 1-symbol length, and further points out that the ACK/NACK and the SRSs are sent at the frequency domain position Q for sending SRSs instead of the frequency domain position P for sending ACK/NACK, so that functions of the SRSs and feedback for the ACK/NACK can be implemented simultaneously, and the SRSs are not sent any longer. Thus, because both SRSs and ACK/NACK adopt a comb structure in frequency domain, sending of the SRSs is eliminated, and the ACK/NACK can be sent.

**[0032]** In addition, it is to be noted that the redefined sequence may be a sequence determined by a person skilled in the art and having good self-correlation, low cross correlation and a low peak-to-average ratio. For example, the redefined sequence is defined as double repetition for sending, at frequency domain positions Y, a sequence (assumed to be defined as a sequence A) used for transmitting the information at frequency domain positions X, the sequence A may be sent at even subcarrier positions of the frequency domain positions Y, an inverted sequence of the sequence A is sent at odd subcarrier positions of the frequency domain positions Y, and it may be ensured that the redefined sequence has a low peak-to-average ratio.

**[0033]** Alternatively, an index of the basic sequence is acquired in at least one of the following manners: allocation by a base station; calculation according to a physical layer cell identity of a cell; obtaining according to a timeslot index; and obtaining according to an index of the TTI.

**[0034]** An index of the cyclic shift is acquired in at least one of the following manners: allocation by a base station; calculation according to a physical layer cell identity of a cell; calculation according to a C-RNTI allocated to a UE by a cell; obtaining according to a timeslot index; and obtaining according to an index of the TTI.

**[0035]** Alternatively, when the predefined pattern is an RS time frequency structure, step 102 may include the sub-step as follows.

**[0036]** The RS is sent by at least using a symbol duration, the RS time frequency structure being used to represent ACK information or NACK information in the information, wherein the RS time frequency structure includes: different symbol positions used by RSs in time domain, or different contiguous subcarrier positions in frequency domain, or different comb subcarrier offsets in frequency domain.

**[0037]** Alternatively, the method may further include the step as follows.

**[0038]** Channel state information is transmitted on the preset time-frequency domain resource, the channel state information including at least one of the following: CQI, PMI, or RI.

**[0039]** Herein, when at least one piece of information included in the channel state information and ACK or NACK included in the information are transmitted simultaneously, independent coding modulation or joint coding modulation is used.

**[0040]** According to an information transmission method provided in the embodiments of the disclosure, firstly, a predefined pattern for carrying information is determined, the predefined pattern includes a predefined sequence or a predefined RS time frequency structure; and then, the predefined pattern carrying the information is transmitted on a preset time-frequency domain resource.

**[0041]** The embodiments of the disclosure also provide a device 10 for transmitting information. As shown in FIG. 2, the device 10 may be arranged in a UE, and includes a determination unit 11 and a transmission unit 12.

**[0042]** The determination unit 11 is arranged to determine a predefined pattern for carrying information, wherein the predefined pattern includes a predefined sequence or a predefined RS time frequency structure.

**[0043]** The transmission unit 12 is arranged to transmit the predefined pattern carrying the information on a preset time-frequency domain resource.

**[0044]** The information includes ACK or NACK.

**[0045]** Alternatively, when the predefined pattern is the predefined sequence, the preset time-

frequency domain resource includes a preset time domain resource and a preset frequency domain resource, wherein the preset time domain resource includes a TTI with a duration of  $K$  symbols, where  $K$  is greater than or equal to 1 and smaller than or equal to 7, and  $K$  is a positive integer; and the preset frequency domain resource includes  $M$  subcarriers, the  $M$  subcarriers being mapped as a comb structure in frequency domain, wherein a frequency domain offset number  $N$  is an integral multiple of 2, and  $M$  is an integral multiple of 12. Alternatively,  $M$  may be 48 or 72.

**[0046]** Alternatively, the predefined sequence has a length  $L$ , which is an integral multiple of 12, a basic sequence of the predefined sequence includes a QPSK-based sequence or a ZC sequence, and a sequence in the predefined sequence is obtained based on the basic sequence.

**[0047]** Alternatively, when  $L$  is greater than 24, the basic sequence of the predefined sequence is the ZC sequence.

**[0048]** Alternatively,  $L$  is 24 or 36. When  $L$  is 24, the basic sequence of the predefined sequence is the QPSK-based sequence. When  $L$  is 36, the basic sequence of the predefined sequence is the ZC sequence.

**[0049]** Alternatively, the transmission unit 12 is arranged to:  
transmit the predefined sequence according to a first preset rule by using the  $M$  subcarriers at the TTI with the duration of  $K$  symbols.

**[0050]** Herein, the first preset rule includes:

for each of the  $K$  symbols, using a different basic sequence for a corresponding predefined sequence to be transmitted in the symbol; or,

for each of the  $K$  symbols, obtaining a corresponding predefined sequence to be transmitted in the symbol by performing a different cyclic shift on a same basic sequence.

**[0051]** Alternatively, the first preset rule further includes:

for each of the  $K$  symbols, using a different comb subcarrier offset of the  $M$  subcarriers; or,

for each of the  $K$  symbols, using a same frequency domain subcarrier position; or,

for the  $K$  symbols, using inter-symbol frequency hopping.

**[0052]** Alternatively, the transmission unit 12 is arranged to:  
transmit the predefined sequence for each symbol of  $K$  symbols in the TTI in the following

manner: transmitting sequences in the predefined sequence by using the M subcarriers in a preset 1-symbol duration.

**[0053]** Alternatively, the preset time domain resource is a TTI having a 1-symbol length, and when a UE needs to send an SRS at a frequency domain position Y whilst needing to send the information at a frequency domain position X, the transmission unit 12 is arranged to: send the information at frequency domain positions Y or a subset of Y within the TTI having a 1-symbol length.

**[0054]** Herein, one or more sequences transmitted at the frequency domain positions Y or the subset of Y and used for carrying the information are sequences used for transmitting the information at frequency domain positions X, or a repetition of sequences used for transmitting the information at frequency domain positions X, or truncation of sequences used for transmitting the information at frequency domain positions X, or punching of sequences used for transmitting the information at frequency domain positions X, or redefined sequences.

**[0055]** Alternatively, an index of the basic sequence is acquired in at least one of the following manners: allocation by a base station; calculation according to a physical layer cell identity of a cell; obtaining according to a timeslot index; and obtaining according to an index of the TTI.

**[0056]** An index of the cyclic shift is acquired in at least one of the following manners: allocation by a base station; calculation according to a physical layer cell identity of a cell; calculation according to a C-RNTI allocated to a UE by a cell; obtaining according to a timeslot index; and obtaining according to an index of the TTI.

**[0057]** Alternatively, when the predefined pattern is an RS time frequency structure, the transmission unit 12 is arranged to: send the RS by at least using a symbol duration, the RS time frequency structure being used to represent ACK information or NACK information in the information, where the RS time frequency structure includes: different symbol positions used by RSs in time domain, or different contiguous subcarrier positions in frequency domain, or different comb subcarrier offsets in frequency domain.

**[0058]** Alternatively, the transmission unit 12 may be further arranged to: transmit channel state information on the preset time-frequency domain resource, the channel state information including at least one of: CQI, PMI, or RI.

**[0059]** Herein, when at least one piece of information included in the channel state information and ACK or NACK included in the information are transmitted simultaneously, independent coding modulation or joint coding modulation is used.

**[0060]** The present embodiment is used to implement each of the above-mentioned method embodiments. A working flow and a working principle of each unit in the present embodiment are determined by description in each of the above-mentioned method embodiments, and will

not be elaborated herein.

**[0061]** According to a device for transmitting information provided in the embodiments of the disclosure, a predefined pattern for carrying information is determined, the predefined pattern includes a predefined sequence or a predefined RS time frequency structure; and the predefined pattern carrying the information is transmitted on a preset time-frequency domain resource. By means of the embodiments of the disclosure, ACK/NACK can be transmitted even when the length of a TTI is shortened in time domain, it is convenient for a receiver to demodulate a predefined pattern without reference information, a hopping gain can be easily achieved, and information can be implicitly transmitted by fully utilizing the positions of RSs to improve the utilization rate of resources.

**[0062]** In order to make a person skilled in the art more clearly understand the technical solutions provided in the disclosure, the technical solutions provided in the disclosure will be described below by means of specific embodiments in detail.

### Embodiment 1

**[0063]** FIG. 3 shows an ACK/NACK transmission structure for a related TTI=1ms PUCCH Format 1/1a/1b with a conventional CP. In a related PUCCH structure, a subframe is occupied in time domain, a PRB is occupied in frequency domain, and inter-timeslot hopping is used. Different cells adopt group hopping to select different QPSK-based basic sequences, and a group hopping period is a timeslot. In the figure,  $r^{(ai)}(n)$  represents a sequence obtained by performing a different cyclic shift on a QPSK basic sequence on each symbol, where  $n=0, 1, 2, \dots, 11$ , representing an index of a sequence element,  $ai$  represents a phase rotation amount or a time domain cyclic shift amount of a corresponding sequence on a symbol  $i$  on the basis of the basic sequence, and  $i=1, 2, 3, 4$ . For different symbols within a same timeslot, a time domain randomization method is employed to obtain different cyclic shift sequences of an identical basic sequence. In addition, in a related structure, a time domain spreading method is employed to increase the number of multiplexing users. However, when a short TTI technology is used to implement delay reduction, the TTI has a length of merely 1 to 7 Single-Carrier Frequency-Division Multiple Access (SC-FDMA) symbols. A related timeslot-based hopping structure and time domain spreading structure cannot be applied.

**[0064]** FIG. 4 shows a sending diagram of K-bit ACK/NACK fed back in a PUCCH when a TTI adopts a single symbol length. In FIG. 4, N UEs send ACK/NACK messages, each UE feeding back K-bit ACK/NACK, respectively represented by  $a_{K-1}, a_{K-2}, \dots, a_1, a_0$ , where ACK at a corresponding bit position is represented by "1", and NACK is represented by "0". A basic sequence adopts cyclic extension of a ZC sequence having a length which is 36, and  $M = 2^{K-1}$  different cyclic shifts, respectively represented by  $CS_0, CS_1, \dots, CS_i, \dots, CS_{2^{K-1}-1}$ , are allocated to each user. ACK/NACK information of each user is mapped to comb subcarriers in frequency domain, a comb subcarrier offset in frequency domain is  $offset=0$  or 1, and a PUCCH occupies

6 PRBs. Further, a decimal number corresponding to a binary sequence formed by  $a_{K-2}, \dots, a_1, a_0$  is defined as  $i$ .

**[0065]** An ACK/NACK sending rule is: when  $K > 1$ , a comb subcarrier offset satisfies  $offset = a_{K-1}$ , and  $a_{K-2}, \dots, a_1, a_0$  is represented by a cyclic shift  $CS_i$ . When  $K = 1$ , a comb subcarrier offset satisfies  $offset = a_{K-1}$ , and an used cyclic shift is  $CS_0$ . When a 1-bit ACK message is sent, the ACK message is sent at a comb position with a subcarrier offset satisfying  $offset = 1$  by using the cyclic shift  $CS_0$ . When 4-bit ACK/NACK is sent, 7 cyclic shifts are allocated. If 0001 is sent, 0001 is sent at a comb position with a subcarrier offset satisfying  $offset = 0$  by using the cyclic shift  $CS_1$ . Meanwhile, it is considered that the probability of transmitting ACK is usually much higher than the probability of transmitting NACK, and when the number of 1 in  $a_{K-2}, \dots, a_1, a_0$  is large, a cyclic shift with better correlation is correspondingly used. Or, it is considered that the target probability of correct NACK demodulation is higher, and when the number of 0 in  $a_{K-2}, \dots, a_1, a_0$  is large, a cyclic shift with better correlation is correspondingly used.

**[0066]** Herein, ACK/NACKs of different users are distinguished by different cyclic shifts of a same ZC sequence. Cyclic shift indexes used by different UEs may be allocated by a base station, or obtained according to a physical layer cell identity of a cell, or calculated according to C-RNTIs allocated to UEs by a cell, or obtained according to a TTI index, or obtained by combining the above-mentioned factors.

**[0067]** In addition, in order to implement simultaneous transmission of SRSs only sent by a user and ACK/NACK messages of other users, different comb subcarrier offsets may be used, or the same comb subcarrier offset but different cyclic shifts may be used.

**[0068]** The advantages of the present embodiment are as follows.

**[0069]** A comb subcarrier mapping mode contributes to increase of a diversity gain in frequency domain, reduces the number of bits for representing ACK/NACK by using a cyclic shift, is convenient for synchronization, and may be used for rapid ACK/NACK feedback during out of synchronization of the uplink.

**[0070]** The comb subcarrier mapping mode may implement simultaneous transmission of an ACK/NACK message and SRSs of other UEs at the same frequency domain position.

**[0071]** A ZC sequence with better correlation reduces interference of the ACK/NACK message between UEs.

## Embodiment 2

**[0072]** FIG. 5 shows a sending diagram of  $K$ -bit ACK/NACK fed back in a PUCCH when a TTI

occupies a 7-symbol length. In FIG. 5, N UEs send uplink ACK/NACK messages, each UE feeding back K-bit ACK/NACK, respectively represented by  $a_{K-1}, a_{K-2}, \dots, a_1, a_0$ . A basic sequence is a QPSK random sequence having a length which is 24, and  $M = 2^{K-1}$  different cyclic shifts, respectively represented by  $CS_{s,0}, CS_{s,1}, \dots, CS_{s,i}, \dots, CS_{s,2^{K-1}-1}$ , are allocated to each SC-FDMA symbol of each user, where s represents a symbol index which is an integer within a value range of 0 to 7, and i is a cyclic shift index within a value range of 0 to  $2^{K-1}-1$ . In the figure,  $r^{(CS_{s,i})}(n)$  represents a sequence obtained by performing a different cyclic shift on a QPSK basic sequence on each symbol, where  $n=0, 1, 2, \dots, 11$ , and n represents an index of a sequence element. A PUCCH occupies 4 PRBs in frequency domain. ACK/NACK information on each symbol is mapped to a comb subcarrier in frequency domain, and a comb subcarrier offset in frequency domain is represented as offset, calculated by the following formula:

$$offset(s) = \begin{cases} a_{K-1} & s \text{ is an even number} \\ \bar{a}_{K-1} & s \text{ is an odd number} \end{cases} \quad (1)$$

where  $\bar{a}_{K-1}$  represents NOT of  $a_{K-1}$ . Further, a decimal number corresponding to a binary sequence formed by  $a_{K-2}, \dots, a_1, a_0$  is defined as i. At an  $s^{\text{th}}$  symbol position, an ACK/NACK sending rule is: when  $K > 1$ ,  $a_{K-1}$  is represented by using a comb subcarrier offset  $offset(s)$ , and  $a_{K-2}, \dots, a_1, a_0$  is represented by using a cyclic shift  $CS_{s,i}$ . When  $K=1$ ,  $a_{K-1}$  is represented by using a comb subcarrier offset  $offset(s)$ , and the cyclic shift used is  $CS_{s,0}$ .

**[0073]** Herein, ACK/NACKs of different users are distinguished by different cyclic shifts of an identical ZC sequence, and comb offsets of different users at the same symbol position may be the same or different.

**[0074]** Herein, cyclic shift indexes and comb offsets used on each SC-FDMA symbol of different UEs may be allocated by a base station, or obtained according to a physical layer cell identity of a cell, or calculated according to C-RNTIs allocated to UEs by a cell, or obtained according to a TTI index, or obtained by combining the above-mentioned factors.

**[0075]** The advantages of the present embodiment are as follows.

**[0076]** A comb subcarrier mapping mode contributes to increase of a diversity gain in frequency domain, reduces the number of bits for representing ACK/NACK by using a cyclic shift, is convenient for synchronization, and may be used for rapid ACK/NACK feedback during out of synchronization of the uplink.

**[0077]** Cyclic shifts and comb offsets used by each UE between different symbols are variable, thereby reducing interference of ACK/NACK messages between different UEs.

### Embodiment 3

**[0078]** FIG. 6 shows a sending diagram of K-bit ACK/NACK fed back in a PUCCH when a TTI occupies a 2-symbol length. In FIG. 6, N UEs send uplink ACK/NACK messages, each UE feeding back K-bit ACKs/NACKs, respectively represented by  $a_{K-1}, a_{K-2}, \dots, a_1, a_0$ . A basic sequence adopts cyclic extension of a ZC sequence having a length  $N_{ZC} = 36$ , and  $M = 2^{K-1}$  different cyclic shifts, respectively represented by  $CS_{s,0}, CS_{s,1}, \dots, CS_{s,i}, \dots, CS_{s,2^{K-1}-1}$ , are allocated to each user, where s represents a symbol index 0 or 1. ACK/NACK information of each user is mapped to different frequency domain positions of two SC-FDMA symbols, frequency domain indexes are  $n_{r,s}$  respectively, namely hopping exists between symbols, and each hopping position occupies 6 PRBs. Each symbol is mapped as a comb structure, and a comb subcarrier offset in frequency domain is offset. When  $s=0$ ,  $offset=a_{K-1}$ ; and when  $s=1$ ,  $offset=a_{K-1}$ .

**[0079]** Further, a decimal number corresponding to a binary sequence formed by  $a_{K-2}, \dots, a_1, a_0$  is defined as i, a decimal number corresponding to a binary sequence formed by  $a_0, a_1, \dots, a_{K-2}$  is defined as j, and an ACK/NACK sending rule is as follows.

**[0080]** At an  $s^{\text{th}}$  symbol position, ACK/NACK is sent at a frequency domain index  $n_{r,s}$ , and when  $K>1$ ,  $a_{K-1}$  may be represented by using a comb subcarrier offset offset; when  $s=0$ ,  $a_{K-2}, \dots, a_1, a_0$  is represented by using a cyclic shift  $CS_{s,i}$ , and when  $s=1$ ,  $a_{K-2}, \dots, a_1, a_0$  is represented by using a cyclic shift  $CS_{s,j}$ . When  $K=1$ ,  $a_{K-1}$  may be represented by using a comb subcarrier offset offset, and a cyclic shift used is  $CS_{s,0}$ .

**[0081]** Herein, ACKs/NACKs of different users are distinguished by different cyclic shifts of an identical ZC sequence. Cyclic shift indexes used by different UEs may be allocated by a base station, or obtained according to a physical layer cell identity of a cell, or calculated according to C-RNTIs allocated to UEs by a cell, or obtained according to a TTI index, or obtained by combining the above-mentioned factors.

**[0082]** The advantages of the present embodiment are as follows.

**[0083]** A comb subcarrier mapping mode contributes to increase of a diversity gain in frequency domain, reduces the number of bits for representing ACKs/NACKs by using a cyclic shift, is convenient for synchronization, and may be used for rapid ACK/NACK feedback during out of synchronization of the uplink.

**[0084]** A ZC sequence with better correlation reduces interference of ACK/NACK messages between UEs.

**[0085]** Hopping between symbols increases a hopping gain.

#### Embodiment 4

[0086] FIG. 7 shows a diagram of joint transmission of K-bit ACK/NACK fed back in a PUCCH and an SRS when a TTI has a single symbol length. In FIG. 7, a frequency domain positions allocated to the ACK/NACK within this TTI symbol are X, a frequency domain positions allocated to the SRS are Y, and both PUCCH and SRS occupy 4 PRBs in frequency domain. There are N UEs, each UE feeding back K-bit ACK/NACK, respectively represented by  $a_{K-1}, a_{K-2}, \dots, a_1, a_0$ . The ACK/NACK and the SRS adopt an identical QPSK-based basic sequence having a length which is  $L_1 = L_2 = 24$ .  $M = 2^{K-1}$  different cyclic shifts, respectively represented by  $CS_0, CS_1, \dots, CS_j, \dots, CS_{2^{K-1}-1}$ , are allocated to each user to transmit the ACK/NACK. ACK/NACK information of each user is mapped to comb-structure subcarriers, and a comb subcarrier offset in frequency domain is  $offset=0$  or  $1$ .

[0087] If a cyclic shift corresponding to  $a_{K-1}, a_{K-2}, \dots, a_1, a_0$  sent by a UE is  $CS_j$  and a comb subcarrier offset in frequency domain is  $offset_j$ , a rule of sending ACK/NACK by the UE is: if only the ACK/NACK is to be sent in the current TTI symbol, the ACK/NACK is sent at the frequency domain positions X by using the cyclic shift  $CS_j$  and the domain offset  $offset_j$ ; and if both the ACK/NACK and the SRS are sent simultaneously in a current TTI symbol, the ACK/NACK is sent at the frequency domain positions Y by using the cyclic shift  $CS_j$  and the domain offset  $offset_j$ .

[0088] An alternative solution for a group hopping method and a cyclic shift selection method in the present embodiment is provided respectively below.

[0089] Herein, a basic sequence index used by each UE may be obtained by the following group hopping method:

$$u = \left( f_{gh} \left( \left\lfloor \frac{t_s}{\Delta_{ts}} \right\rfloor \right) + f_{ss} \right) \bmod 30 \quad (1)$$

where  $t_s$  is a TTI index within a value range of 0, 1, 2, ..., 139,  $\Delta_{ts}$  represents a group hopping period, and  $\Delta_{ts}$  is obtained by high-layer configuration.

$$f_{gh}(t) = \begin{cases} 0 & \text{group hopping disabled.} \\ \left( \sum_{i=0}^7 c(8t+i) \cdot 2^i \right) \bmod 30 & \text{group hopping enabled.} \end{cases} \quad (2)$$

$c(i)$  is a pseudorandom sequence defined in a 3GPP TS 36.211, and initialization data used here is

$$c_{init} = \left\lfloor \frac{N_{ID}^{cell}}{30} \right\rfloor$$

$$f_{ss} = N_{ID}^{cell} \bmod 30, \text{ and}$$

$$N_{ID}^{cell}$$

is a physical layer cell identity within a value range of 0 to 503.

[0090] Assuming

$$\Delta_{is} = N_{\text{symp}}^{UL}$$

, where

$$N_{\text{symp}}^{UL}$$

is the number of SC-FDMA symbols within each timeslot, synchronization between ACK/NACK group hopping and related SRS group hopping based on a single symbol TTI can be implemented. That is, within the same cell, ACK/NACK information and SRSs adopt the same basic sequence.

[0091] A cyclic shift used by each UE may be determined by using the following algorithm:

$$\begin{aligned} CS_i(t_s) &= 2\pi \cdot n_i(t_s) / L_1 \\ n_i(t_s) &= \left[ n'_i(t_s) \cdot \Delta_{\text{shift}}^{\text{PUCCH}} \right] \bmod L_1 \end{aligned} \quad (3)$$

$$\begin{aligned} n'_i(t_s) &= \left( \left\lfloor \frac{L_1}{2^{k-1}} \right\rfloor + n'_0(t_s) \right) \bmod L_1, \quad i = 1, 2, \dots, 2^{k-1} - 1 \\ n'_0(t_s) &= n_{\text{PUCCH}}^{(1, \tilde{p})} \bmod N, \quad N = \left\lfloor \frac{L_1}{2^{k-1} * \Delta_{\text{shift}}^{\text{PUCCH}}} \right\rfloor \end{aligned} \quad (4)$$

where  $CS_i(t_s)$  represents an  $i^{\text{th}}$  cyclic shift used by a UE within a TTI of which an index is  $t_s$ ,  $n_i(t_s)$  represents a corresponding cyclic shift index,

$$n_{\text{PUCCH}}^{(1, \tilde{p})}$$

is a resource channel index, and is associated with a C-RNTI allocated to a UE by a cell, and

$$\Delta_{\text{shift}}^{\text{PUCCH}}$$

is a cyclic shift interval. If each user sends 2-bit ACK/NACK,

$$\Delta_{\text{shift}}^{\text{PUCCH}} = 3$$

, and the length of a basic sequence is  $L_1 = 24$ , the supported number  $N$  of multiplexing users can be 4, and two cyclic shifts are to be allocated to each UE. Intermediate values

$$n'_0(t_s)$$

corresponding to different UEs may be 0, 1, 2, 3. Indexes  $n_0(t_s)$  corresponding to 0<sup>th</sup> cyclic shifts of 4 UEs are 0, 3, 6, 9 respectively, and indexes  $n_1(t_s)$  corresponding to first cyclic shifts are 12, 15, 18, 21 respectively, that is, two cyclic shifts used by 4 UEs are: (0, 12), (3, 15), (6, 18), (9, 21) respectively.

[0092] The method for determining group hopping and the cyclic shift are only an alternative solution of the present embodiment. Basic sequences, cyclic shifts and comb offsets used by different UEs may also be allocated by a base station, or obtained according to a physical layer cell identity of a cell, or calculated according to C-RNTIs allocated to UEs by a cell, or obtained according to a TTI index, or obtained by combining the above-mentioned factors.

[0093] The advantages of the present embodiment are as follows.

[0094] A comb subcarrier mapping mode contributes to increase of a diversity gain in frequency domain, reduces the number of bits for representing ACK/NACK by using a cyclic shift, is convenient for synchronization, and may be used for rapid ACK/NACK feedback during out of synchronization of the uplink.

[0095] Compatible coexistence of basic sequence group hopping and frequency domain hopping for ACK/NACK information and SRS information is implemented, and simultaneous transmission of the ACK/NACK information and the SRS information can be implemented.

[0096] The cyclic shift determination method provided in the present embodiment may uniformly discretize cyclic shift intervals of different UEs, thereby reducing interference between different UEs.

### Embodiment 5

[0097] FIG. 8 shows an example of joint transmission of a K-bit ACK/NACK message fed back in a PUCCH and an SRS when a TTI has a single symbol length. It is assumed that frequency domain positions allocated to ACK/NACK within a TTI symbol are X, frequency domain positions allocated to SRSs are Y, a PUCCH occupies 4 PRBs in frequency domain, and SRSs occupy 8 PRBs in frequency domain. In FIG. 8, there are N UEs, each UE feeding back K-bit ACK/NACK, respectively represented by  $a_{K-1}, a_{K-2}, \dots, a_1, a_0$ . The ACK/NACK adopts a QPSK-based basic sequence of which the length is  $L_1 = 24$ , and the SRS adopts a ZC basic sequence of which the length is  $L_2 = 48$ .  $M = 2^{K-1}$  different cyclic shifts, respectively represented by  $CS_0, CS_1, \dots, CS_j, \dots, CS_{2^{K-1}-1}$ , are allocated to each user to transmit the ACK/NACK. ACK/NACK information of each user is mapped to comb-structure subcarriers, and a comb subcarrier offset in frequency domain is  $offset=0$  or  $1$ .

[0098] It is assumed that a cyclic shift corresponding to  $a_{K-1}, a_{K-2}, \dots, a_1, a_0$  sent by a UE is  $CS_j$  and a comb subcarrier offset in frequency domain is  $offset_j$ . A bit reversal repetition sequence of sequence  $CS_j$  is defined as

$$CS'_j$$

, which is calculated as:

$$\begin{cases} CS'_j(2k) = CS'_j(k) \\ CS'_j(2k+1) = CS'_j(L_1+1-k) \end{cases} \quad (5)$$

$$k = 0, 1, 2, \dots, L_1 - 1$$

[0099] A rule of sending ACK/NACK by the UE is: if only the ACK/NACK is sent in a current TTI symbol, the ACK/NACK is sent at the frequency domain positions X by using the cyclic shift  $CS_j$  and the domain offset  $offset_j$ ; and if the ACK/NACK and the SRS are sent simultaneously in the

current TTI symbol, the ACK/NACK is sent at the frequency domain positions  $Y$  by using the bit reversal repetition

$$CS'_i$$

and the domain offset  $offset_i$ .

**[0100]** Herein, basic sequences, cyclic shifts and comb offsets used by different UEs may also be allocated by a base station, or obtained according to a physical layer cell identity of a cell, or calculated according to C-RNTIs allocated to UEs by a cell, or obtained according to a TTI index, or obtained by combining the above-mentioned factors.

**[0101]** The advantages of the present embodiment are as follows.

**[0102]** A comb subcarrier mapping mode contributes to increase of a diversity gain in frequency domain, reduces the number of bits for representing ACK/NACK by using a cyclic shift, is convenient for synchronization, and may be used for rapid ACK/NACK feedback during out of synchronization of the uplink.

**[0103]** Compatible coexistence of basic sequence group hopping and frequency domain hopping for ACK/NACK information and SRS information is implemented, and simultaneous transmission of the ACK/NACK information and the SRS information can be implemented.

**[0104]** The bit reversal repetition sequence designed in the present embodiment has a better peak-to-average ratio.

#### Embodiment 6

**[0105]** FIG. 9 shows a sending diagram of joint transmission of a full-bandwidth mapped ACK/NACK message and an SRS when a TTI occupies a single symbol length. In FIG. 9, a PUCCH bandwidth is  $B$  MHz, totally used for bearing an ACK/NACK message and an SRS message. Each UE feeds back  $K$ -bit ACK/NACK, respectively represented by  $a_{K-1}, a_{K-2}, \dots, a_1, a_0$ . The ACK/NACK and the SRS adopt the same basic sequence adopting cyclic extension of a ZC sequence.  $2^K - 1$  different cyclic shifts, respectively represented by  $CS_0, CS_1, \dots, CS_i, \dots, CS_{2^K - 2}$ , are allocated to each user to represent the ACK/NACK, and a cyclic shift, represented by  $CS_{SRS}$ , is allocated to each user to represent the SRS. ACK/NACK information and SRS information of each user are mapped to comb subcarriers in frequency domain, a comb subcarrier offset of the ACK/NACK in frequency domain is  $offset=0$ , and a comb subcarrier offset of the SRS in frequency domain is  $offset=1$ . Further, a decimal number corresponding to a binary sequence formed by  $a_{K-2}, \dots, a_1, a_0$  is defined as  $i$ .

**[0106]** A rule of sending ACK/NACK by a UE is: if only the ACK/NACK is sent in a current TTI symbol, when  $i=0$ , any information is not sent at the subcarrier offset  $offset$  in frequency

domain=0; and when  $i > 0$ ,  $a_{K-1}, a_{K-2}, \dots, a_1, a_0$  is represented by using a cyclic shift  $CS_{i-1}$  at the subcarrier offset  $offset=0$  in frequency domain. If a current TTI symbol sends the ACK/NACK and the SRS simultaneously, when  $i=0$ , any information is not sent at the subcarrier offset  $offset=1$  in frequency domain; and when  $i > 0$ ,  $a_{K-1}, a_{K-2}, \dots, a_1, a_0$  is represented by using a cyclic shift  $CS_{i-1}$  at the subcarrier offset  $offset=1$  in frequency domain.

**[0107]** Herein, ACK/NACKs between different users and SRSs between different users are distinguished by using different cyclic shifts of an identical ZC sequence. Cyclic shift indexes used by different UEs may be allocated by a base station, or calculated according to C-RNTIs of a cell, or calculated according to C-RNTIs allocated to UEs by a cell, or obtained according to a TTI index, or obtained by combining the above-mentioned factors.

### Embodiment 7

**[0108]** FIG. 10 shows a sending diagram of 1-2bit ACK/NACK messages fed back in a PUCCH when a TTI occupies a 2-symbol length. 1-2bit ACK/NACK messages are implicitly represented by mapping RSs to different symbols or different subcarrier positions, where Data may be used to transmit other signaling in a PUCCH such as CQI/PMI/RI.

**[0109]** When only 1-bit ACK/NACK information is fed back, the information may be sent by using the structure as shown in FIG. 10-1. For example, a receiver may determine whether ACK or NACK is fed back by blindly detecting two positions of an RS. The two positions may be determined according to, not limited to a symbol position of ACK/NACK, or may be implicitly determined by mapping the RS to non-contiguous comb subcarriers via different offsets of the comb subcarriers.

**[0110]** When 2-bit ACK/NACK information is to be fed back, the structure as shown in FIG. 10-2 or the structure combined with the structure as shown in FIG. 10-1 may be used. For example, a receiver may determine fed-back 2-bit ACK/NACK information by blindly detecting four positions of an RS. The four positions are not limited to the structure as shown in FIG. 10, or are implicitly determined by mapping the RS to non-contiguous comb subcarriers via different offsets of the comb subcarriers.

**[0111]** The implicit transmission used in the present embodiment is advantageous in that ACK/NACK information can be effectively fed back without additional time-frequency resources.

### Embodiment 8

**[0112]** FIG. 11 shows a sending diagram of 1-2bit ACK/NACK messages fed back in a PUCCH when a TTI occupies a 7-symbol length. 1-2bit ACK/NACK information is implicitly represented by different mapping symbol positions of an RS, where Data may be used to transmit other

signaling of a PUCCH, such as CQI/PMI/RI.

**[0113]** 1-2bit ACK/NACK information is implicitly represented by different RS positions preferentially, but not limited to the following RS mapping positions. FIG. 11-1 shows an alternative pattern of two RS positions, and FIG. 11-2 shows an alternative pattern containing only one RS. In order to avoid conflict between Data and the RS at the same position, it may be defined that the Data and the RS are distinguished by using different cyclic shifts.

**[0114]** Herein, basic sequences and cyclic shifts used by data symbols and RSs of different UEs may be allocated by a base station, or calculated according to C-RNTIs of a cell, or calculated according to C-RNTIs allocated to UEs by a cell, or obtained according to a TTI index, or obtained by combining the above-mentioned factors.

**[0115]** In FIG. 11-2, a corresponding relationship between different RS positions and ACK/NACK may be as follows.

**[0116]** When 2-bit ACK/NACK information is to be fed back, 2-bit NACK information is represented by ①, and 2bit ACK information is represented by ④. That is, an RS position corresponding to the NACK information should be near the front as much as possible, thereby reducing delay of data re-preparation by an eNB for NACK feedback.

**[0117]** Or, when 2-bit ACK/NACK information is to be fed back, 2-bit ACK information is represented by ①, and 2-bit NACK information is represented by ④. That is, an RS position corresponding to the ACK information should be near the front as much as possible. Because the probability of ACK feedback is greater than the probability of NACK feedback, the statistic average delay is reduced.

**[0118]** The implicit transmission used in the present embodiment is advantageous in that ACK/NACK information can be effectively fed back without additional time-frequency resources. The present embodiment may also be applied to a related 1ms PUCCH Format 2 structure.

**[0119]** The embodiments of the disclosure also provide a computer storage medium in which a computer-executable instruction is stored. The computer-executable instruction is used to execute the method in the above-mentioned embodiments.

**[0120]** Those of ordinary skill in the art may understand that all or some of the steps in the above-mentioned method may be completed by instructing related hardware (e.g., processor) through a program. The program may be stored in a computer-readable storage medium such as a read-only memory, a magnetic disk or an optical disk. Alternatively, all or some of the steps in the above-mentioned embodiments may be implemented by using one or more integrated circuits. Accordingly, each module/unit in the above-mentioned embodiments may be implemented in a form of hardware, and for example, corresponding functions thereof are implemented by means of an integrated circuit. Each module/unit may also be implemented in a form of software function module, and for example, corresponding functions thereof are

implemented by executing programs/instructions stored in a memory by the processor. The disclosure is not limited to the combination of hardware and software in any specific form.

**[0121]** Although the implementation manner disclosed in the disclosure is as above, the content is only the implementation manner used for convenience of understanding the disclosure, not intended to limit the disclosure. The scope of patent protection of the disclosure must be determined with reference to the scope defined by the appended claims.

## **REFERENCES CITED IN THE DESCRIPTION**

Cited references

This list of references cited by the applicant is for the reader's convenience only. It does not form part of the European patent document. Even though great care has been taken in compiling the references, errors or omissions cannot be excluded and the EPO disclaims all liability in this regard.

### **Patent documents cited in the description**

- EP2605442A2 **[0006]**

### **Non-patent literature cited in the description**

- **TEXAS INSTRUMENTS**SACK/NAK Transmission without Reference Signal Overhead in E-UTRA Uplink3GPP DRAFT; R1-070275, **[0005]**

## PATENTKRAV

1. Fremgangsmåde til informationsoverførsel, **kendetegnet ved** at omfatte:  
bestemmelse (101) af et foruddefineret mønster til at repræsentere informationer, hvor det  
5 foruddefinerede mønster omfatter en foruddefineret sekvens, og informationerne omfatter  
bekræftelse (Acknowledgement, ACK) eller negativ bekræftelse (Negative Acknowledgement,  
NACK); og  
overførsel (102) af det foruddefinerede mønster, der repræsenterer informationerne på en  
forudindstillet tidsfrekvensdomæneressource,  
10 hvor, når det foruddefinerede mønster er den foruddefinerede sekvens, den forudindstillede  
tidsfrekvensdomæneressource omfatter en forudindstillet tidsdomæneressource og en  
forudindstillet frekvensdomæneressource; den forudindstillede tidsdomæneressource omfatter et  
overførselstidsinterval (Transmission Time Interval, TTI), med en varighed på  $K$  symboler, hvor  
 $K$  er større end eller lig med 1 og mindre end eller lig med 7, og er et positivt heltal; og den  
15 forudindstillede frekvensdomæneressource omfatter  $M$  underbærere, der  $M$  underbærere  
kortlægges som en kamstruktur i frekvensdomæne, hvor et frekvensdomænes forskydningsantal  
 $N$  er et helt multiplum af 2, og  $M$  er et helt multiplum af 12, hvor frekvensdomæneforskydningen  
indikerer en forskydning af et initialt underbærerindeks i forhold til et lavest indeks af tilsvarende  
ressourceblokke, hvor de  $M$  underbærere kortlægges som kamstrukturen i frekvensdomænet, og  
20 frekvensdomæneforskydningsantallet er et samlet antal af frekvensdomæneforskydningerne.
2. Fremgangsmåde ifølge krav 1, hvor den foruddefinerede sekvens har en længde  $L$ , der er  
et helt multiplum af 12, en basissekvens af den foruddefinerede sekvens omfatter en Quadrature  
Phase Shift Keying-, QPSK-baseret sekvens eller en Zadoff-Chu-, ZC, sekvens og en sekvens i  
25 den foruddefinerede sekvens opnås baseret på basissekvensen.
3. Enhed til informationsoverførsel, **kendetegnet ved** at omfatte:  
en bestemmelsesenhed (11) indrettet til at bestemme et foruddefineret mønster til at repræsentere  
informationer, hvor det foruddefinerede mønster omfatter en foruddefineret sekvens, og  
30 informationerne omfatter bekræftelse (Acknowledgement, ACK) eller negativ bekræftelse  
(Negative Acknowledgement, NACK); og  
en overføringsenhed (12) indrettet til at overføre det foruddefinerede mønster, der repræsenterer  
informationerne på en forudindstillet tidsfrekvensdomæneressource,

hvor, når det foruddefinerede mønster er den foruddefinerede sekvens, den forudindstillede tidsfrekvensdomæneressource omfatter en forudindstillet tidsdomæneressource og en forudindstillet frekvensdomæneressource; den forudindstillede tidsdomæneressource omfatter overførelstidsinterval (Transmission Time Interval, TTI), med en varighed på  $K$  symboler, hvor  $K$  er større end eller lig med 1 og mindre end eller lig med 7, og  $K$  er et positivt heltal; og den forudindstillede frekvensdomæneressource omfatter  $M$  underbærere, hvilke  $M$  underbærere kortlægges som en kamstruktur i frekvensdomæne, hvor et frekvensdomænes forskydningsantal  $N$  er et helt multiplum af 2, og  $M$  er et helt multiplum af 12, hvor frekvensdomæneforskydningen indikerer en forskydning af et initialt underbærerindeks i forhold til et lavest indeks af tilsvarende ressourceblokke, hvor de  $M$  underbærere kortlægges som kamstrukturen i frekvensdomænet, og frekvensdomæneforskydningsantallet er et samlet antal af frekvensdomæneforskydningerne.

# DRAWINGS

Drawing

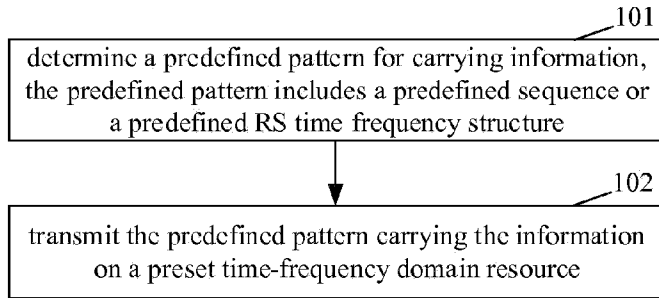

FIG. 1

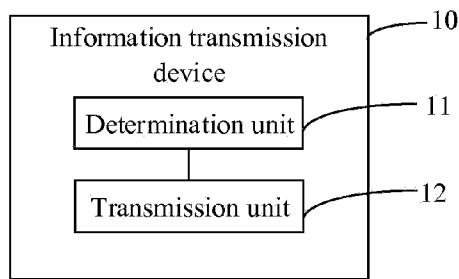

FIG. 2

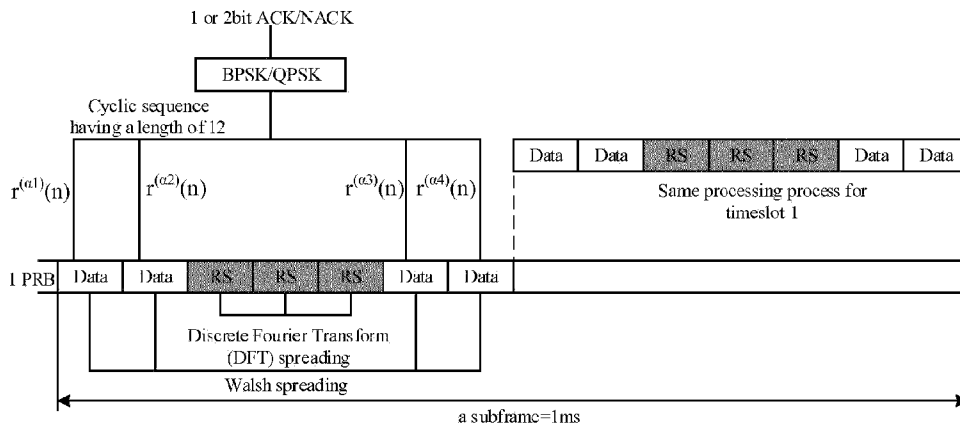

FIG. 3

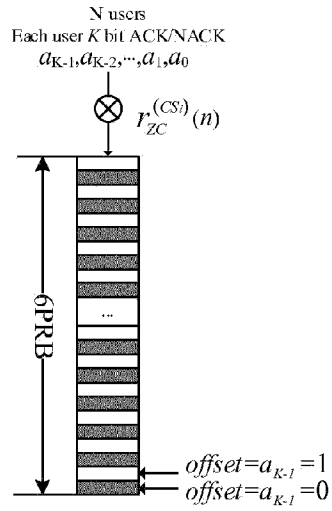

FIG. 4

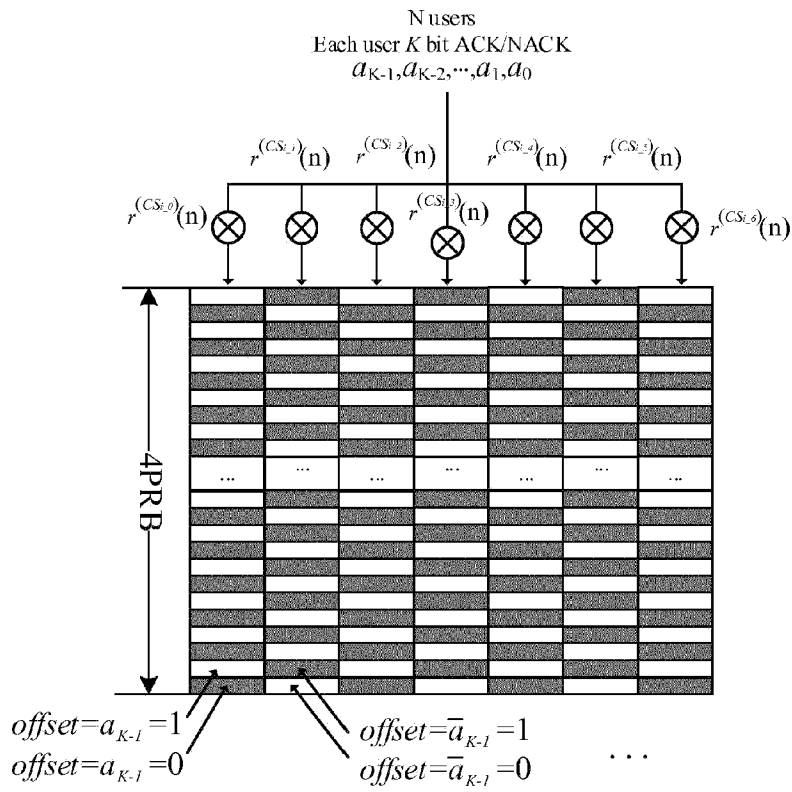

FIG. 5

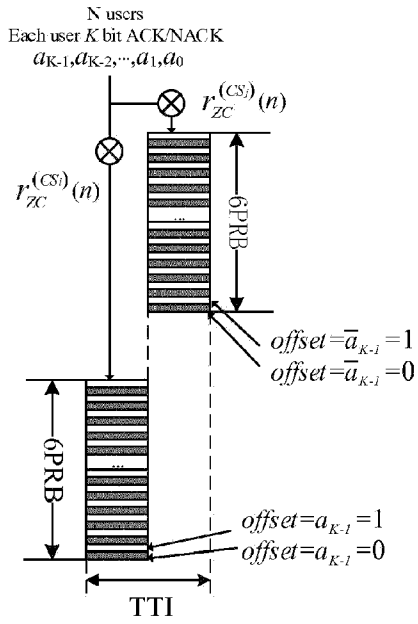

FIG. 6

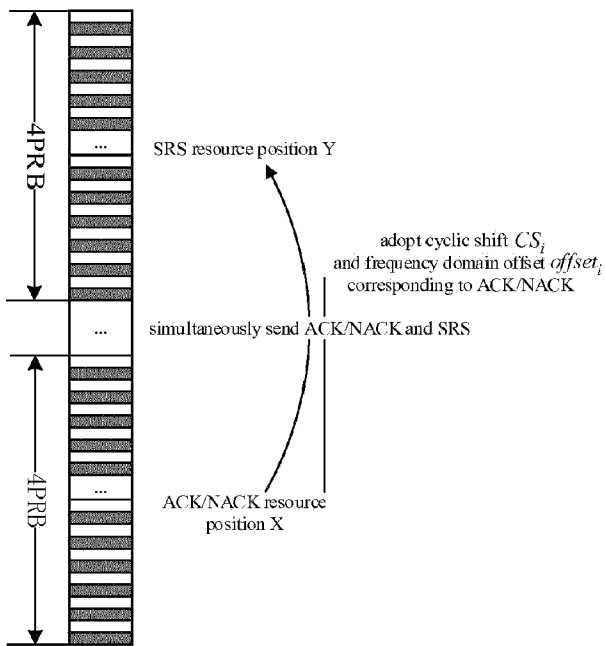

FIG. 7

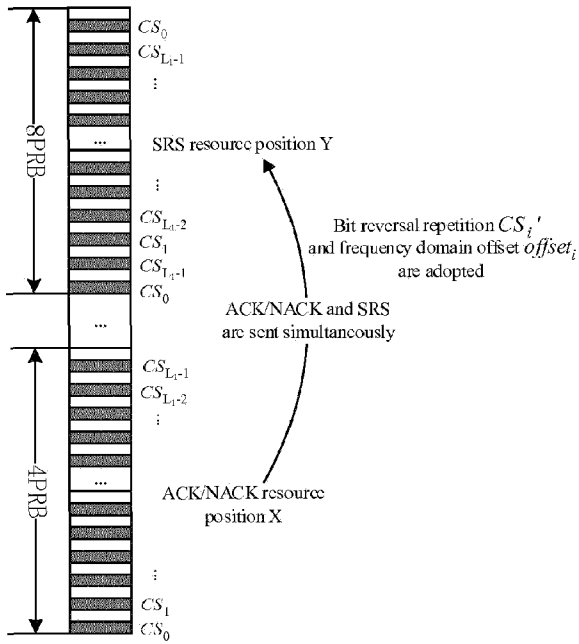

FIG. 8

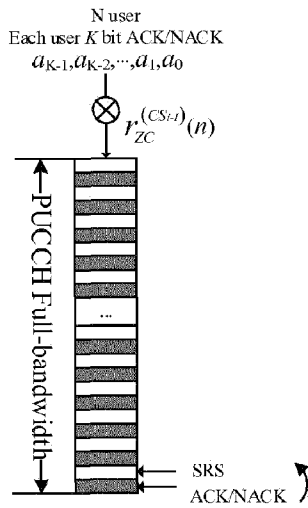
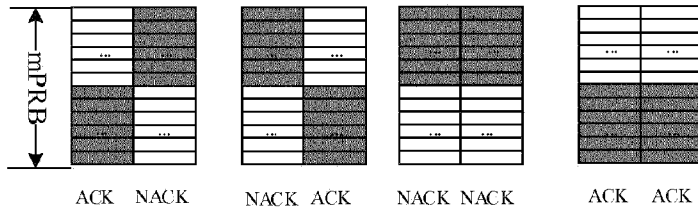
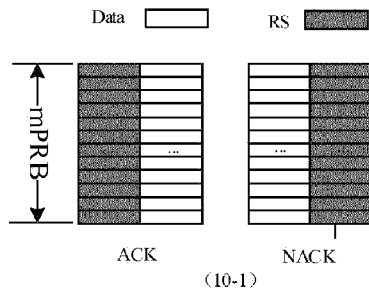
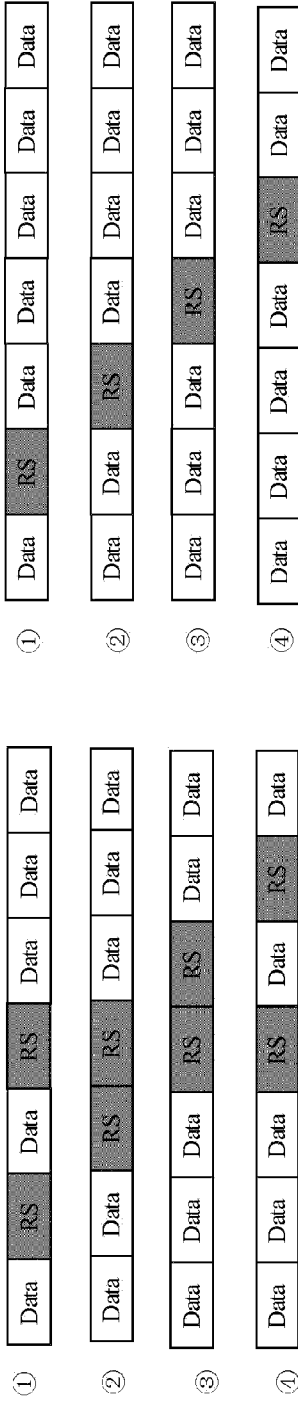

FIG. 9



**FIG. 10**



(11-1)

(11-2)

**FIG. 11**