

(19) World Intellectual Property
Organization
International Bureau



(43) International Publication Date
7 April 2005 (07.04.2005)

PCT

(10) International Publication Number
WO 2005/031451 A1

- (51) International Patent Classification⁷: G02F 1/167, G02B 26/02, C09D 5/44
- (21) International Application Number: PCT/JP2004/014699
- (22) International Filing Date: 29 September 2004 (29.09.2004)
- (25) Filing Language: English
- (26) Publication Language: English
- (30) Priority Data: 2003-338554 29 September 2003 (29.09.2003) JP
- (71) Applicant (for all designated States except US): CANON KABUSHIKI KAISHA [JP/JP]; 30-2, Shimomaruko 3-chome, Ohta-ku, Tokyo 146-8501 (JP).
- (72) Inventor; and
- (75) Inventor/Applicant (for US only): MINAMI, Masato [JP/JP]; 4-12-128, Morinosato, Atsugi-Shi, Kanagawa 243-0122 (JP).
- (74) Agent: YAMADA, Ryuichi; Toko International Patent Office, Hasegawa Bldg. 4F, 7-7, Toranomom 3-chome, Minato-ku, Tokyo 105-0001 (JP).
- (81) Designated States (unless otherwise indicated, for every kind of national protection available): AE, AG, AL, AM, AT, AU, AZ, BA, BB, BG, BR, BW, BY, BZ, CA, CH, CN, CO, CR, CU, CZ, DE, DK, DM, DZ, EC, EE, EG, ES, FI, GB, GD, GE, GH, GM, HR, HU, ID, IL, IN, IS, KE, KG, KP, KR, KZ, LC, LK, LR, LS, LT, LU, LV, MA, MD, MG, MK, MN, MW, MX, MZ, NA, NI, NO, NZ, OM, PG, PH, PL, PT, RO, RU, SC, SD, SE, SG, SK, SL, SY, TJ, TM, TN, TR, TT, TZ, UA, UG, US, UZ, VC, VN, YU, ZA, ZM, ZW.
- (84) Designated States (unless otherwise indicated, for every kind of regional protection available): ARIPO (BW, GH, GM, KE, LS, MW, MZ, NA, SD, SL, SZ, TZ, UG, ZM, ZW), Eurasian (AM, AZ, BY, KG, KZ, MD, RU, TJ, TM), European (AT, BE, BG, CH, CY, CZ, DE, DK, EE, ES, FI, FR, GB, GR, HU, IE, IT, LU, MC, NL, PL, PT, RO, SE, SI, SK, TR), OAPI (BF, BJ, CF, CG, CI, CM, GA, GN, GQ, GW, ML, MR, NE, SN, TD, TG).
- Published:
— with international search report
- For two-letter codes and other abbreviations, refer to the "Guidance Notes on Codes and Abbreviations" appearing at the beginning of each regular issue of the PCT Gazette.

(54) Title: ELECTROPHORETIC DISPERSION LIQUID AND ELECTROPHORETIC DISPLAY DEVICE

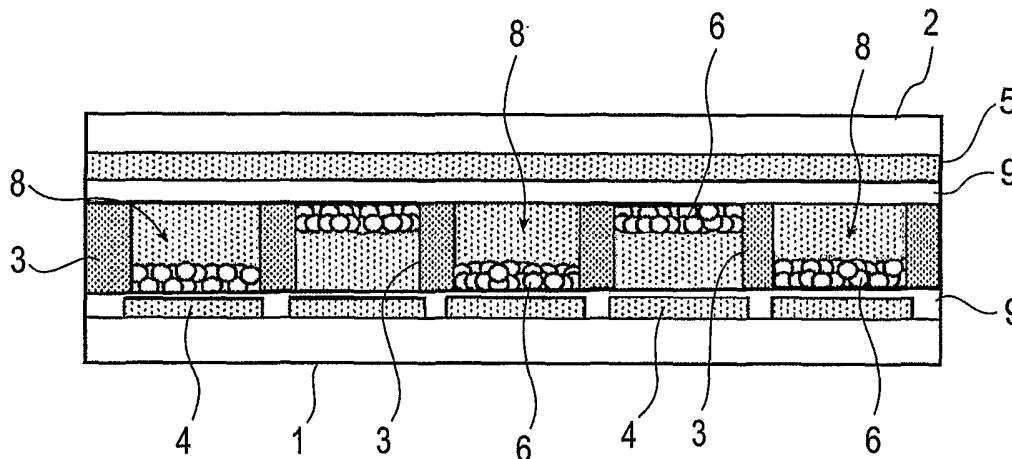

(57) Abstract: An electrophoretic dispersion liquid (8) for an electrophoretic display apparatus includes a plurality of electrophoretic particles (6) each surface of which is modified by one of a basic group and an acidic group, a liquid for holding said electrophoretic particles to be dispersed therein; and a polydiene, having the other group, dissolved in said liquid.

WO 2005/031451 A1

DESCRIPTION

ELECTROPHORETIC DISPERSION LIQUID
AND ELECTROPHORETIC DISPLAY DEVICE

5

[TECHNICAL FIELD]

The present invention relates to electrophoretic dispersion liquid and an electrophoretic display device using the electrophoretic particles. Particularly, the present invention relates to a polymer as one component of the electrophoretic dispersion liquid.

[BACKGROUND ART]

15 In recent years, with development of information equipment, the needs for low-power and thin display devices have grown, so that extensive study and development have been made on display devices fitted to these needs. Of these display devices, a liquid crystal display devices has been developed actively as a display device capable of meeting the needs by electrically controlling alignment of liquid crystal molecules to change optical characteristic of the liquid crystal and has been brought into the commercial stage.

25 However, such a liquid crystal display device is accompanied with such problems that it has poor

viewability of characters on a picture area due to a viewing angle or reflection light and that an eyestrain problem caused by flickering, low luminance, etc., of a light source is not sufficiently solved.

5 As a conventionally known display device which is low power consumption and thin and capable of solving the eyestrain problem, U.S. Patent No. 3,612,758 has proposed an electrophoretic display device.

10 In the electrophoretic display device, a multiplicity of electrophoretic particles which are, e.g., positively charged and colored are dispersed in a space between a pair of substrates, each provided with an electrode, together with an electrophoretic
15 dispersion liquid which is filled in the space and colored a color different from the color of the electrophoretic particles. Between the pair of substrates, a partition wall is formed so that it divides the space into a multiplicity of pixels along
20 a planar direction of the substrates. By forming such a partition wall, it is possible to define the space between the pair of substrates while preventing movement of the electrophoretic particles in a pixel to other pixels and keeping uniform display.

25 In such an electrophoretic display device, when a positive-polarity voltage is applied to an observer's side electrode and a negative-polarity

voltage is applied to an electrode on an opposite side, the positively charged electrophoretic particles are collected so as to cover the opposite side electrode, so that the color of the electrophoretic dispersion liquid (dispersion medium) is displayed when the electrophoretic display device is observed in such a state.

On the other hand, when a negative-polarity voltage is applied to the observer's side electrode and a positive-polarity voltage is applied to the opposite side electrode, the positively charged electrophoretic particles are collected so as to cover the observer's side electrode, so that the color of the electrophoretic particles is displayed when the electrophoretic display device is observed in such a state.

By performing such a drive of the electrophoretic display device on a pixel-by-pixel basis, any image or character is displayed by a multiplicity of pixels.

In a conventional electrophoretic display device, an electrophoretic dispersion liquid is prepared by adding, e.g., an electrifying agent or a dispersing agent into an insulating dispersion medium to impart a chargeability (electrification characteristic) and a dispersibility to electrophoretic particles. The chargeability of the

electrophoretic particles results from creation of zeta potential at particle surface, and the dispersibility results from steric-exclusion effect by adsorption of the dispersing agent onto the particle surface.

U.S. Patent No. 5,380,362 has disclosed such a method that a chargeability and a dispersibility are imparted to pigment particles in an electrophoretic dispersion liquid colored with a dye by using yellow pigment particles having an acidic site in combination with a charge control agent having a polymer chain containing a basic group.

Further, U.S. Patent No. 6,590,696 has disclosed such a method that a chargeability and a dispersibility are imparted to particles in an electrophoretic dispersion liquid comprising a hydrocarbon solvent, particles having an acidic group (or a basic group), a basic (or acidic) polymer, and a compound having a nonionic polar group.

However, in the above described conventional electrophoretic display devices using electrophoretic dispersion liquids, additives have been precipitated at low temperatures in some cases. Particularly, in a low temperature environment of 0 °C to -20 °C, when the electrophoretic display devices are driven, a polymeric additive is precipitated, thus causing a deterioration in display performance of the

electrophoretic display devices.

[DISCLOSURE OF THE INVENTION]

An object of the present invention is to
5 provide an electrophoretic dispersion liquid for an
electrophoretic display device capable of displaying
desired image and character with reliability without
causing a deterioration of display performance even in
a low temperature environment (e.g., from 0 °C to
10 -20 °C).

Another object of the present invention is to
provide a display apparatus using the electrophoretic
dispersion liquid.

According to the present invention, there is
15 provided an electrophoretic dispersion liquid for an
electrophoretic display apparatus, comprising:

a plurality of electrophoretic particles each
surface of which is modified by one of a basic group
and an acidic group,

20 a liquid for holding the electrophoretic
particles to be dispersed therein, and

a polydiene, having the other group, dissolved
in the liquid.

According to the present invention, there is
25 also provided a display apparatus, comprising:

an electrophoretic dispersion liquid which
comprises a plurality of electrophoretic particles

each surface of which is modified by one of a basic group and an acidic group, a liquid for holding the electrophoretic particles to be dispersed therein, and a polydiene, having the other group, dissolved in the liquid;

a closed cell for holding the electrophoretic dispersion liquid, and

a first electrode and a second electrode for generating an electric field in the closed cell.

In the display apparatus, a voltage of a polarity which is alternately changed is applied between the first and second electrodes, and the electrophoretic particles are moved by an electric field generated by the first and second electrodes.

The present invention is characterized in that a polydiene having an acidic group is used as an acidic polymer in an electrophoretic dispersion liquid, containing the acidic polymer, which is filled in a space between a pair of substrates disposed opposite to each other and in which a plurality of electrophoretic particles each surface-modified by an acidic group are dispersed in an insulating liquid. In this case, the polydiene may preferably be a graft polydiene having an acidic group which has been grafted.

The present invention is also characterized in that a polydiene having a basic group is used as a

basic polymer in an electrophoretic dispersion liquid,
containing the basic polymer, which is filled in a
space between a pair of substrates disposed opposite
to each other and in which a plurality of
5 electrophoretic particles each surface-modified by an
basic group are dispersed in an insulating liquid. In
this case, the polydiene may preferably be a graft
polydiene having a basic group which has been grafted.

In the present invention, the polydiene
10 described above may preferably be polydiene or
polyisoprene.

The present invention further provides an
electrophoretic display apparatus comprising a pair of
substrates disposed with a spacing, and an
15 electrophoretic dispersion liquid, disposed in the
spacing, containing a plurality of electrophoretic
particles which are dispersed therein and electrically
moved to effect display, characterized in that any one
of the above described electrophoretic dispersion
20 liquids as the electrophoretic dispersion liquid for
the electrophoretic display apparatus,

The present invention is further characterized
in that each of the pair of substrates is provided
with an electrophoretic and a polarity of a voltage
25 applied between the electrodes is changed thereby to
move the electrophoretic particles.

The present invention is further characterized

in that the pair of substrates are a first substrate provided with a first electrode and a second substrate which is disposed on an observer's and is provided with a second electrode, and a polarity of a voltage applied between the first and second electrodes is changed thereby to move the electrophoretic particles.

These and other objects, features and advantage of the present invention will become more apparent upon a consideration of the following description of the preferred embodiments of the present invention taken in conjunction with the accompanying drawings.

[BRIEF DESCRIPTION OF THE DRAWINGS]

Figure 1 is a schematic sectional view showing an embodiment of an electrophoretic display device using an electrophoretic dispersion liquid according to First Embodiment of the present invention.

Figures 2(a) and 2(b) are schematic views showing a display example of the electrophoretic display device.

Figure 3 is a schematic sectional view showing another embodiment of the electrophoretic display device.

Figure 4 is a schematic sectional view showing an embodiment of an electrophoretic display device using an electrophoretic dispersion liquid according

to Second Embodiment of the present invention.

Figures 5(a) and 5(b) are schematic views showing a display example of the electrophoretic display device of Second Embodiment.

5 Figure 6 is a schematic sectional view showing another embodiment of the electrophoretic display device of Second Embodiment.

[BEST MODE FOR CARRYING OUT THE INVENTION]

10 Herein, the term "electrophoretic dispersion liquid" refers to a dispersion liquid comprising electrophoretic particles, a liquid for holding the electrophoretic particles in a dispersion state, and other substances inclusive of additives contained in
15 the liquid. Accordingly, the electrophoretic dispersion liquid contains not only a liquid component but also a solid component such as solid particles. Further, the electrophoretic particles refers to particles which are electrically charged and moved in
20 the electrophoretic dispersion liquid by applying thereto an electric field and are at least visually recognizable in their collected state. In other words, herein, particles which are, e.g., suspended in the liquid in an ionic state or an electrically charged
25 state, are not the electrophoretic dispersion liquid.

Hereinbelow, preferred embodiments of the present invention will be described in detail with

reference to the drawings.

(First Embodiment)

Figure 1 is a sectional view of an electrophoretic display device using an electrophoretic dispersion liquid according to First Embodiment of the present invention.

As shown in Figure 1, the electrophoretic display device includes a first substrate 1, a second substrate 2, and a partition wall 3 disposed so that the first and second substrates 1 and 2 are oppositely disposed with a spacing. The first substrate 1 is provided with a first substrate 4, and the second substrate 2 is provided with a second substrate 5.

In a cell (space) defined by the first and second substrates 1 and 2 disposed with the spacing and the partition wall 3, an electrophoretic dispersion liquid 8 which comprises a plurality of electrophoretic particles 6 dispersed therein, an electrophoretic dispersion medium, and a polymer is sealed. On each of the first and second substrates 4 and 5, an insulating layer 9 is formed. A display surface of the electrophoretic display device is located on the second substrate 2 side.

The first electrode 4 is a pixel electrode and comprises a plurality of electrode portions which are independently capable of applying a desired electric field to the electrophoretic dispersion liquid 8 in an

associated cell of the respective cells.

The first electrode 4 (pixel electrode) is provided with an unshown switching element (for each electrode portion) and is supplied with a selection
5 signal from an unshown matrix drive circuit row by row and also supplied with a control signal and an output from an unshown drive transistor column by column. As a result, it is possible to apply a desired electric field to the electrophoretic dispersion liquid 8
10 (electrophoretic particles 6) in each of the cells.

When the electric field is applied through the first electrode 4 as described above, the electrophoretic particles 6 in each individual cell are moved toward the first electrode 4 or the second
15 electrode 5 depending on an electric field applied through by the first electrode 4. By the movement of the electrophoretic particles 6, at each pixel, the color (e.g., white) of the electrophoretic particles 6 and the color (e.g., blue) of the electrophoretic
20 dispersion liquid 8 (electrophoretic dispersion medium) are selectively displayed. By effecting such a drive on a pixel-by-pixel basis, it is possible to effect display of arbitrary images and characters by use of corresponding pixels.

25 The first electrode 4 may be formed of a metal (vapor) deposition film of ITO (indium tin oxide), tin oxide, indium oxide, gold, chromium, etc., in a

predetermined pattern through a photolithographic process. The second electrode 5 may be a transparent electrode formed of ITO film or an organic electroconductive film.

5 The first substrate 1 provided with the first electrode 4 may comprise an arbitrary insulating member, for supplying the electrophoretic display, such as glass or plastics. Further, the second substrate 2 provided with the second electrode 5 may
10 comprise an insulating member, such as a transparent glass substrate or a transparent plastic substrate.

 The insulating layer 9 can be formed of a colorless transparent insulating resin, such as acrylic resin, epoxy resin, fluorine-based resin,
15 silicone resin, polyimide resin, polystyrene resin, or polyalkene resin.

 The partition wall 3 can be formed of a polymeric material through, e.g., a method wherein the partition wall is formed with a photosensitive resin
20 through the photolithographic process, a method wherein the partition wall which has been prepared in advance is bonded to the substrate, a method wherein the partition wall is formed through molding, or the like.

25 The method of filling the electrophoretic dispersion liquid 8 is not particularly limited but can be an ink jet method using nozzles.

As described above, in the electrophoretic dispersion liquid of the present invention, a basic polymer or an acidic polymer is added to a dispersion medium depending on an acidic group or a basic group of the electrophoretic particles. In the case where the electrophoretic particles are surface-modified by the basic group, as a polymer for imparting the chargeability and the dispersibility to the electrophoretic particles, an acidic polymer is used. In the present invention, as the acidic polymer, a polydiene having an acidic group is used. It is preferable that a graft polydiene having a grafted acidic group, such as polybutadiene or polyisoprene.

The polybutadiene and the polyisoprene have a T_g (glass transition point) of about $-100\text{ }^\circ\text{C}$ and a T_g of about $-70\text{ }^\circ\text{C}$, respectively. These polydienes have no crystal structure and are consisting only of noncrystalline portions, so that they assume large elongation property and flexibility, thus being widely used in rubber uses etc. A crystalline polymer having a number-average molecular weight of about 5,000 is ordinarily solid at room temperature. However, polydienes having the same molecular weight are characterized in that they are liquid polymers at room temperature and have a high solubility in a nonpolar solvent.

The acidic polymer is soluble in the

electrophoretic dispersion medium described specifically later. The electrophoretic dispersion liquid 8 in which the acidic polymer is dissolved in the electrophoretic dispersion medium is does not
5 cause precipitation at least in the temperature range of -20°C to 0°C .

The number-average molecular weight of the acidic polymer used in the present invention may preferably be 1,000 - 100,000, more preferably
10 10,000 - 50,000. When the acidic polymer has the number-average molecular weight in such ranges, the acidic polymer fixed at the surfaces of the electrophoretic particles 6 can sufficiently exhibit a steric-exclusion effect by an acid-base interaction.
15 Further, it is also possible to ensure a solubility thereof in the electrophoretic dispersion medium.

The number of acidic groups in the acidic polymer varies depending on the molecular weight of the acidic polymer but may preferably be 1 - 50 per
20 one molecule, more preferably 3 - 20 per one molecule. When there is no acidic group in the acidic polymer, the resultant polymer fails to perform, formation of salt caused by the acid-base interaction and its dissociation with respect to the electrophoretic
25 particles surface-modified with the basic group, thus failing to impart the dispersibility and the chargeability to the electrophoretic particles. On the

other hand, the number of acidic groups in the acidic polymer is in the range of 1 - 50/molecule, the acidic polymer may suitably be used without causing a lowering in solubility in the electrophoretic dispersion medium.

The addition amount of the acidic polymer may preferably be 0.01 to 3 times, more preferably 0.1 to 1.5 times, a weight of the electrophoretic particles. When the acidic polymer is added in such ranges, the acidic polymer can sufficiently form a salt caused by the acid-base interaction and its dissociation with respect to the electrophoretic particles surface-modified with the basic group, thus imparting the dispersibility or the chargeability to the electrophoretic particles. Such an acidic polymer is preferable since there is no excessive acidic polymer which does not attribute to the interaction with the electrophoretic particles surface-modified with the basic group.

As the acidic polymer 8, it is possible to use polydienes represented by the following [Formula 1] to [Formula 4]:

[Formula 1]

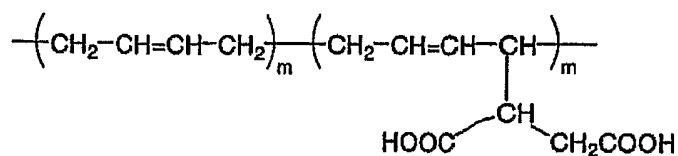

[Formula 2]

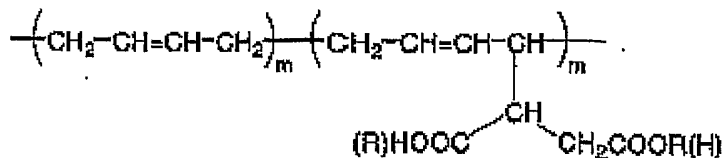

[Formula 3]

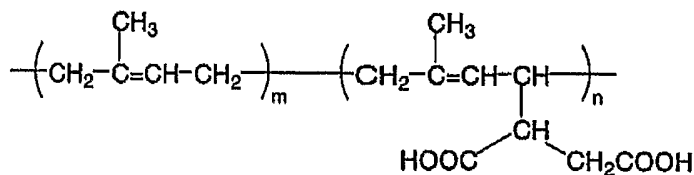

5

[Formula 4]

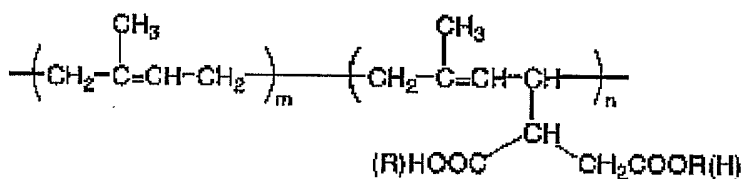

10 In the above [Formula 2] and [Formula 4], R represents a linear or branched alkyl group having 1 - 18 carbon atoms. Further, when the structure has a monoester portion, the monoester portion may include isomers.

15 Examples of the acidic polymer 8 may include: those of [Formula 1], such as polybutadiene-graft-maleic acid; those of [Formula 2], such as polybutadiene-graft-monomethyl maleate, polybutadiene-graft-monoethyl maleate,

20 polybutadiene-graft-monopropyl maleate,

polybutadiene-graft-monobutyl maleate,
polybutadiene-graft-monopentyl maleate,
polybutadiene-graft-monoethyl maleate,
polybutadiene-graft-mono(2-ethylhexyl)maleate,
5 polybutadiene-graft-monoheptyl maleate,
polybutadiene-graft-monooctyl maleate,
polybutadiene-graft-monononyl maleate,
polybutadiene-graft-monodecyl maleate,
polybutadiene-graft-monododecyl maleate,
10 polybutadiene-graft-monotetradecyl maleate,
polybutadiene-graft-monohexadecyl maleate, and
polybutadiene-graft-monostearyl maleate; those of
[Formula 3], such as polyisoprene-graft-maleic acid;
and those of [Formula 4],
15 polyisoprene-graft-monomethyl maleate,
polyisoprene-graft-monoethyl maleate,
polyisoprene-graft-monopropyl maleate,
polyisoprene-graft-monobutyl maleate,
polyisoprene-graft-monopentyl maleate,
20 polyisoprene-graft-monoethyl maleate,
polyisoprene-graft-mono(2-ethylhexyl)maleate,
polyisoprene-graft-monoheptyl maleate,
polyisoprene-graft-monooctyl maleate,
polyisoprene-graft-monononyl maleate,
25 polyisoprene-graft-monodecyl maleate,
polyisoprene-graft-monododecyl maleate,
polyisoprene-graft-monotetradecyl maleate,

polyisoprene-graft-monohexadecyl maleate, and
polyisoprene-graft-monostearyl maleate.

On the other hand, in this embodiment, in the
case where the electrophoretic particles 6 are
5 surface-modified by the acidic group, as a polymer for
imparting the chargeability and the dispersibility to
the electrophoretic particles 6, a basic polymer 8 is
used. In the present invention, as the basic polymer 8,
a polydiene having a basic group is used. It is
10 preferable that a graft polydiene having a grafted
basic group, such as polybutadiene or polyisoprene.

The basic polymer is soluble in the
electrophoretic dispersion medium described
specifically later. The electrophoretic dispersion
15 liquid 8 in which the basic polymer is dissolved in
the electrophoretic dispersion medium is does not
cause precipitation at least in the temperature range
of -20°C to 0°C .

The number-average molecular weight of the
20 basic polymer used in the present invention may
preferably be 1,000 - 100,000, more preferably
10,000 - 50,000. When the basic polymer has the
number-average molecular weight in such ranges, the
basic polymer fixed at the surfaces of the
25 electrophoretic particles 6 can sufficiently exhibit a
steric-exclusion effect by an acid-base interaction.
Further, it is also possible to ensure a solubility

thereof in the electrophoretic dispersion medium.

The number of basic groups in the basic polymer varies depending on the molecular weight of the acidic polymer but may preferably be 1 - 50 per one molecule, more preferably 3 - 20 per one molecule. When there is no basic group in the basic polymer, the resultant polymer fails to perform, formation of salt caused by the acid-base interaction and its dissociation with respect to the electrophoretic particles surface-modified with the acidic group, thus failing to impart the dispersibility and the chargeability to the electrophoretic particles. On the other hand, the number of basic groups in the basic polymer is in the range of 1 - 50/molecule, the basic polymer may suitably be used without causing a lowering in solubility in the electrophoretic dispersion medium.

The addition amount of the basic polymer may preferably be 0.01 to 3 times, more preferably 0.1 to 1.5 times, a weight of the electrophoretic particles. When the basic polymer is added in such ranges, the basic polymer can sufficiently form a salt caused by the acid-base interaction and its dissociation with respect to the electrophoretic particles surface-modified with the acidic group, thus imparting the dispersibility or the chargeability to the electrophoretic particles. Such a basic polymer is

preferable since there is no excessive basic polymer which does not attribute to the interaction with the electrophoretic particles 6 surface-modified with the acidic group.

5 As the basic polymer 8, it is possible to use polydienes represented by the following [Formula 5] to [Formula 8]:

[Formula 5]

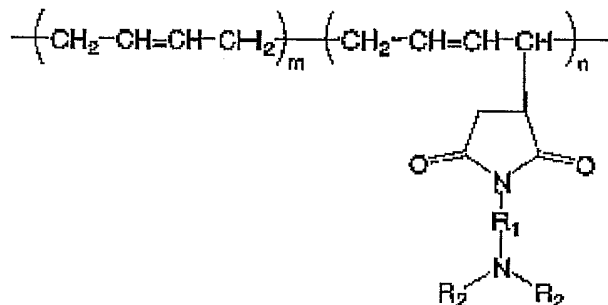

10

[Formula 6]

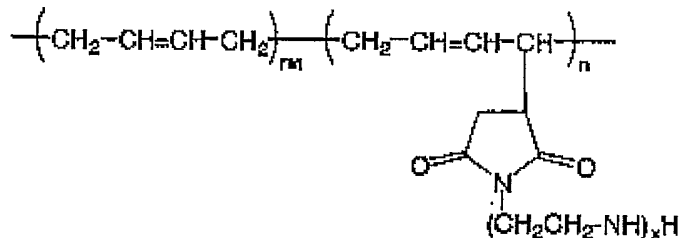

[Formula 7]

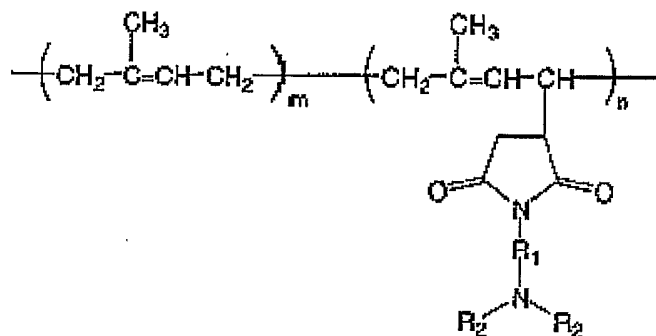

15

[Formula 8]

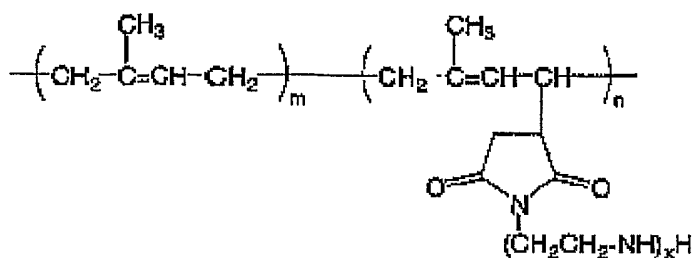

In the above [Formula 5] and [Formula 7], R1 represents an alkylene group having 1 - 18 carbon atoms and R2 represents a linear or branched alkyl group having 1 - 18 carbon atoms. Further, in the above [Formula 6] and [Formula 8], X represents an integer of 2 - 4.

Examples of the basic polymer 8 may include:

those of [Formula 5], such as

polybutadiene-graft-N-(aminomethyl)maleimide,

polybutadiene-graft-N-(2-aminoethyl)maleimide,

polybutadiene-graft-N-(4-aminobutyl)maleimide,

polybutadiene-graft-N-(6-aminoethyl)maleimide,

polybutadiene-graft-N-(dimethylaminomethyl)maleimide,

polybutadiene-graft-N-(2-(dimethylamino)ethyl)maleimide,

polybutadiene-graft-N-(4-(dimethylamino)butyl)maleimide,

polybutadiene-graft-N-(6-dimethylamino)hexyl)-

maleimide, polybutadiene-graft-N-(diethylaminomethyl)-

maleimide, polybutadiene-graft-N-(2-diethylamino)-

ethyl)maleimide, polybutadiene-graft-N-(4-(diethylamino)butyl)maleimide,

polybutadiene-graft-N-(6-(diethylamino)hexyl)maleimide,
polybutadiene-graft-N-(dipropylaminomethyl)maleimide,
polybutadiene-graft-N-(2-(dipropylamino)ethyl)maleimid
e,
5 polybutadiene-graft-N-(4-dipropylamino)butyl)maleimide,
polybutadiene-graft-N-(6-dipropylamino)hexyl)maleimide,
polybutadiene-graft-N-(dibutylaminomethyl)maleimide,
polybutadiene-graft-N-(2-dibutylamino)ethyl)maleimide,
polybutadiene-graft-N-(4-dibutylamino)butyl)maleimide,
10 polybutadiene-graft-N-(6-(dibutylamino)hexyl)maleimide,
polybutadiene-graft-N-(dihexylaminomethyl)maleimide,
polybutadiene-graft-N-(2-dihexylamino)ethyl)maleimide,
polybutadiene-graft-N-(4-(dihexylamino)butyl)maleimide,
polybutadiene-graft-N-(6-(dihexylamino)hexyl)maleimide,
15 polybutadiene-graft-N-(di(2-ethylhexyl)aminomethyl)mal
eimide, poly-
butadiene-graft-N-(2-(di(2-ethylhexyl)amino)ethyl)-
maleimide, polybutadiene-graft-N-(4-(di(2-ethylhexyl)-
amino)butyl)maleimide,
20 polybutadiene-graft-N-(6-(di(2-ethylhexyl)amino)hexyl)
maleimide,
polybutadiene-graft-N-(dioctylaminomethyl)maleimide,
polybutadiene-graft-N-(2-(dioctylamino)ethyl)maleimide,
polybutadiene-graft-N-(4-(dioctylamino)butyl)maleimide,
25 polybutadiene-graft-N-(6-(dioctylamino)hexyl)maleimide,
polybutadiene-graft-N-(didecylaminomethyl)maleimide,
polybutadiene-graft-N-(2-(didecylamino)ethyl)maleimide,

polybutadiene-graft-N-(4-(didecylamino)butyl)maleimide,
polybutadiene-graft-N-(6-(didecylamino)hexyl)maleimide,
polybutadiene-graft-N-(didodecylaminomethyl)maleimide,
polybutadiene-graft-N-(2-(didodecylamino)ethyl)maleimi
5 de,
polybutadiene-graft-N-(4-(didodecylamino)butyl)maleimi
de, poly-
butadiene-graft-N-(6-(didodecylamino)hexyl)maleimide,
polybutadiene-graft-N-(distearylaminomethyl)maleimide,
10 polybutadiene-graft-N-(2-(distearylaminomethyl)ethyl)-
maleimide, polybutadiene-graft-N-(4-(distearylaminomethyl)-
butyl)maleimide, and
polybutadiene-graft-N-(6-(distearylaminomethyl)hexyl)maleimi
de; those of [Formula 6], such as
15 polybutadiene-graft-N-(2-((2-aminoethyl)-
amino)ethyl)maleimide,
polybutadiene-graft-N-(2-((2-((2-aminoethyl)amino)ethyl)
amino)ethyl)maleimide, and
polybutadiene-graft-N-(2-((2-((2-((2-aminoethyl)-
20 amino)ethyl)amino)ethyl)amino)ethyl)maleimide; those
of [Formula 7], such as
polyisoprene-graft-N-(aminomethyl)maleimide,
polyisoprene-graft-N-(2-aminoethyl)maleimide,
polyisoprene-graft-N-(4-aminobutyl)maleimide,
25 polyisoprene-graft-N-(6-aminoethyl)maleimide,
polyisoprene-graft-N-(dimethylaminomethyl)maleimide,
polyisoprene-graft-N-(2-(dimethylamino)ethyl)maleimide,

polyisoprene-graft-N-(4-(dimethylamino)butyl)maleimide,
polyisoprene-graft-N-(6-dimethylamino)hexyl)maleimide,
polyisoprene-graft-N-(diethylaminomethyl)maleimide,
polyisoprene-graft-N-(2-diethylamino)ethyl)maleimide,
5 polyisoprene-graft-N-(4-(diethylamino)butyl)maleimide,
polyisoprene-graft-N-(6-(diethylamino)hexyl)maleimide,
polyisoprene-graft-N-(dipropylaminomethyl)maleimide,
polyisoprene-graft-N-(2-(dipropylamino)ethyl)maleimide,
polyisoprene-graft-N-(4-dipropylamino)butyl)maleimide,
10 polyisoprene-graft-N-(6-dipropylamino)hexyl)maleimide,
polyisoprene-graft-N-(dibutylaminomethyl)maleimide,
polyisoprene-graft-N-(2-dibutylamino)ethyl)maleimide,
polyisoprene-graft-N-(4-dibutylamino)butyl)maleimide,
polyisoprene-graft-N-(6-(dibutylamino)hexyl)maleimide,
15 polyisoprene-graft-N-(dihexylaminomethyl)maleimide,
polyisoprene-graft-N-(2-dihexylamino)ethyl)maleimide,
polyisoprene-graft-N-(4-(dihexylamino)butyl)maleimide,
polyisoprene-graft-N-(6-(dihexylamino)hexyl)maleimide,
polyisoprene-graft-N-(di(2-ethylhexyl)aminomethyl)male
20 imide,
polyisoprene-graft-N-(2-(di(2-ethylhexyl)amino)ethyl)-
maleimide, polyisoprene-graft-N-(4-(di(2-ethylhexyl)-
amino)butyl)maleimide,
polyisoprene-graft-N-(6-(di(2-ethylhexyl)amino)hexyl)m
25 aleimide,
polyisoprene-graft-N-(dioctylaminomethyl)maleimide,
polyisoprene-graft-N-(2-(dioctylamino)ethyl)maleimide,

polyisoprene-graft-N-(4-(dioctylamino)butyl)maleimide,
polyisoprene-graft-N-(6-(dioctylamino)hexyl)maleimide,
polyisoprene-graft-N-(didecylaminomethyl)maleimide,
polyisoprene-graft-N-(2-(didecylamino)ethyl)maleimide,
5 polyisoprene-graft-N-(4-(didecylamino)butyl)maleimide,
polyisoprene-graft-N-(6-(didecylamino)hexyl)maleimide,
polyisoprene-graft-N-(didodecylaminomethyl)maleimide,
polyisoprene-graft-N-(2-(didodecylamino)ethyl)-
maleimide, polyisoprene-graft-N-(4-(didodecylamino)-
10 butyl)maleimide, polyisoprene-graft-N-(6-(didodecyl-
amino)hexyl)maleimide,
polyisoprene-graft-N-(distearylaminomethyl)maleimide,
polyisoprene-graft-N-(2-(distearylamino)ethyl)maleimid
e,
15 polyisoprene-graft-N-(4-(distearylamino)butyl)maleimid
e, and polyisoprene-graft-N-(6-(distearylamino)hexyl)-
maleimide; those of [Formula 8], such as poly-
isoprene-graft-N-(2-((2-aminoethyl)amino)ethyl)-
maleimide, polyisoprene-graft-N-(2-((2-((2-amino-
20 ethyl)amino)ethyl)amino)ethyl)maleimide, and
polyisoprene-graft-N-(2-((2-((2-((2-aminoethyl)-
amino)ethyl)amino)ethyl)amino)ethyl)maleimide.

As the electrophoretic dispersion medium, it
is possible to use a liquid, which is high insulative
25 and colorless and transparent, including: aromatic
hydrocarbons, such as toluene, xylene, ethylbenzene
and dodecylbenzene; aliphatic hydrocarbons, such as

hexane, cyclohexane, kerosine, normal paraffin and isoparaffin; halogenated hydrocarbons, such as chloroform, dichloromethane, pentachloroethane, 1,2-dibromoethane, 1,1,2,2-tetrabromoethane, 5 trichloroethylene, tetrachloroethylene, trifluoroethylene and tetrafluoroethylene, various natural or synthetic oils, etc. These may be used singly or in mixture of two or more species.

The electrophoretic dispersion liquid may be 10 colored with oil soluble dye having a color of R (red), G (green), B (blue), C (cyan), M (magenta), Y (yellow), etc. Examples of the dye may preferably include azo dyes, anthraquinone dyes, quinoline dyes, nitro dyes, nitroso dyes, phenoline dyes, phthalocyanine dyes, 15 metal complex salt dyes, naphthol dyes, benzoquinone dyes, cyanine dyes, indigo dyes, quinoimine dyes, etc. These may be used in combination.

Other examples of the oil soluble dye may include Vari Fast Yellow (1101, 1105, 3108, 4120), Oil 20 Yellow (105, 107, 129, 3G, GGS), Vari Fast Red (1306, 1355, 2303, 3304, 3306, 3320), Oil Pink 312, Oil Scarlet 308, Oil Violet 730, Vari Fast Blue (1501, 1603, 1605, 1607, 2606, 2610, 3405). Oil Blue (2N, BOS, 613), Macrolex Blue RR, Sumiplast Gren G, Oil Green 25 (502, BG), etc. A concentration of these dyes may preferably be 0.1 - 3.5 wt. %, per the electrophoretic dispersion medium 7.

As the electrophoretic particles 6 used in the present invention, it is possible to use particles of an organic pigment and an inorganic pigment which are surface-modified with an acidic group or a basic group, particles comprising a polymer modified with an acidic group or a basic group and a pigment dispersed in the polymer, particles comprising a polymer which is modified with an acidic group or a basic group and colored with a dye, etc. An average particle size of these particles may be 10 nm to 10 μm , preferably 15 nm to 5 μm .

The particles comprising the polymer modified with the acidic group or the basic group and the pigment dispersed in the polymer may be obtained by polymerizing an acidic monomer containing the pigment or a basic monomer containing the pigment.

As the polymer modified with the acidic group used for such particles, it is possible to use homopolymers of acidic monomers, such as (meth)acrylic acid, 2-butenic acid (crotonic acid), 3-butenic acid, (vinyl acetate), 3-methyl-3-butenic acid, 3-pentenoic acid, 4-pentenoic acid, 4-methyl-4-pentenoic acid, 4-hexenoic acid, 5-hexenoic acid, 5-methyl-5-hexenoic acid, 5-heptenoic acid, 6-heptenoic acid, 6-methyl-6-heptenoic acid, 6-octenoic acid, 7-octenoic acid, 7-methyl-7-octenoic acid, 7-nonenoic acid, 8-nonenoic acid, 8-methyl-8-nonenoic acid, 8-decenoic

acid, 9-decenoic acid, 3-phenyl-2-propenoic (cinnamic acid), carboxymethyl (meth)acrylate, carboxyethyl (meth)acrylate, vinyl benzoate, vinylphenyl acetate, vinylphenyl propionate, maleic acid, fumaric acid, 5 methylenesuccinic acid (itaconic acid), hydroxystyrene, styrenesulfonic acid, vinyltoluenesulfonic acid, vinylsulfonic acid, sulfomethyl (meth)acrylate, 2-sulfoethyl (meth)acrylate, 2-propene-1-sulfonate, 2-methyl-2-propene-1-sulfonate, and 10 3-butene-1-sulfonate. It is also possible to use copolymers of the above described acidic monomers with olefin (alkene), diene, etc. Examples of olefin (alkene) may include ethylene, propylene, butene, isobutene, pentene, hexene, etc. Examples of diene may 15 include butadiene, isoprene, etc.

On the other hand, as the polymer modified with the basic group, it is possible to use homopolymers of basic monomers, such as (meth)acrylate; ethyl (meth)acrylate, propyl (meth)acrylate, butyl 20 (meth)acrylate, pentyl (meth)acrylate, hexyl (meth)acrylate, heptyl (meth)acrylate, octyl (meth)acrylate, nonyl (meth)acrylate, decyl (meth)acrylate, dodecyl (meth)acrylate, tetradecyl (meth)acrylate, hexadecyl (meth)acrylate, phenyl 25 (meth)acrylate, benzyl (meth)acrylate, N-methylaminoethyl (meth)acrylate, N-ethylaminoethyl (meth)acrylate, N-propylaminoethyl (meth)acrylate,

N-butylaminoethyl (meth)acrylate, N-pentylaminoethyl (meth)acrylate, N-hexylaminoethyl (meth)acrylate, N-octylaminoethyl (meth)acrylate, N-decylaminoethyl (meth)acrylate, N,N-dimethylaminoethyl (meth)acrylate, 5 N,N-diethylaminoethyl (meth)acrylate, N,N-dipropylaminoethyl (meth)acrylate, N,N-dibutylaminoethyl (meth)acrylate, N,N-dipentylaminoethyl (meth)acrylate, N,N-dihexylaminoethyl (meth)acrylate, N,N-dioctylaminoethyl (meth)acrylate, N,N-didecyl- 10 aminoethyl (meth)acrylate, (meth)acrylamide, N-methyl (meth)acrylamide, N-ethyl (meth)acrylamide, N-propyl (meth)acrylamide, N-butyl (meth)acrylamide, N,N-dimethyl (meth)acrylamide, N,N-diethyl (meth)acrylamide, N,N-dipropyl (meth)acrylamide, N,N-dibutyl 15 (meth)acrylamide, dimethylaminostyrene, diethylaminostyrene, dibutylaminostyrene, vinylpyridine, and vinyl pyrrolidone. It is also possible to use copolymers of the above described basic monomers with olefin (alkene), diene, etc. Examples of olefin (alkene) and 20 diene may include those described above therefor.

Examples of organic pigments may include azo pigments, phthalocyanine pigments, quinacridone pigments, isoindolinone pigments isoindolin pigments, dioxazine pigments, perylene pigments, perinone 25 pigments, thioindigo pigments, quinophthalone pigments, anthraquinone pigments, nitro pigments, and nitroso pigments. Specific examples thereof may include: red

pigments, such as Quinacridone Red, Lake Red, Brilliant Carmine, Perylene Red, Permanent Red, Toluidine Red and Madder Lake; green pigments, such as Diamond Green Lake, Phthalocyanine Green, and Pigment
5 Green; blue pigments, such as Victoria Blue Lake, Phthalocyanine Blue, and Fast Sky Blue; yellow pigments, such as Hansa Yellow, Fast Yellow, Disazo Yellow, Isoindolinone Yellow, an Quinophthalone Yellow; and black pigments, such as Aniline Black and
10 Diamond Black.

Examples of the inorganic pigments may include: white pigments, such as titanium oxide, aluminum oxide, zinc oxide, lead oxide, and zinc sulfide; black pigments, such as carbon black, manganese ferrite
15 block, cobalt ferrite black, and titanium black; red pigments, such as cadmium red, red iron oxide, and molybdenum red; green pigments, such as chromium oxide, viridian, titanium cobalt green, cobalt green, and victoria green; blue pigments, such as ultramarine
20 blue, prussian blue, and cobalt blue; and yellow pigments, such as cadmium yellow, titanium yellow, yellow iron oxide, chrome yellow, and antimony yellow.

As the particles comprising the polymer, modified with the acidic group or the basic group,
25 colored with a dye, it is possible to use, e.g., particles comprising polymer particles, modified with the acidic group or the basic group, colored with a

dye or particles obtained through polymerization of an acidic monomer containing a dye or of a basic monomer containing a dye. As the acidic monomer and the basic monomer, it is possible to use those described above
5 therefor.

Next, a display operation of the electrophoretic display device using the above described electrophoretic dispersion liquid according to this embodiment will be described.

10 Figures 2(a) and 2(b) illustrate a display example wherein, e.g., an electrophoretic dispersion liquid 8 comprising white electrophoretic particles 6 surface-modified with a basic group, an electrophoretic dispersion medium colored with a blue
15 dye, and an acidic polymer is filled in a cell. In these figures, the same signs or reference numerals as in Figure 1 represent the same or corresponding members or means as in the structure shown in Figure 1. The electrophoretic particles 6 surface-modified with
20 the basic group is positively charged by the acid-base interaction with the acidic polymer.

When an electric field E is applied to the electrophoretic dispersion liquid in the direction shown in Figure 2(a), the positively charged
25 electrophoretic particles 6 are moved toward the upper side of the cell and distributed over the upper display surface. As a result, when the cell is

observed from above, the cell looks white due to distribution of the white electrophoretic particles 6. On the other hand, when the electric field E is applied to the electrophoretic dispersion liquid in the arrow direction shown in Figure 2(b), the white electrophoretic particles 6 are moved toward the bottom of the cell and distributed thereover, so that the cell looks blue when observed from above. Such a driving operation is effected pixel by pixel, whereby arbitrary images or characters can be displayed by using a large number of pixels.

As described above, as the acidic or basic polymer for impairing the chargeability and the dispersibility to the electrophoretic particles 6, the basic polymer having the acidic or basic group which is not precipitated in the electrophoretic dispersion medium at least in the low temperature environment of -20 to 0 °C is used. As a result, it is possible to provide an electrophoretic dispersion liquid 8 with reliability without causing deterioration in display quality even in the low temperature environment and an electrophoretic display device using the electrophoretic dispersion liquid 8.

In the above embodiment, the electrophoretic display device having such a structure that the electrophoretic dispersion liquid 8 is filled in the cell is described but an electrophoretic display

device having such a structure, as shown in Figure 3, that microcapsules 10 each containing therein electrophoretic particles 6 and an electrophoretic dispersion liquid 8 is disposed in place of the cell
5 between a first substrate 1 and a second substrate 2. In the case of using such microcapsules 10, an insulating layer (9 shown in Figures 2(a) and 2(b)) may be omitted.

By controlling the electrophoretic particles
10 in each microcapsule 10 under application of an electric field through a first electrode 4, it is possible to effect display of an arbitrary image or character.

The microcapsule 10 can be prepared by a known
15 method, such as interfacial polymerization, in-situ polymerization, coacervation, etc. As a material for constituting the microcapsule 10, it is preferred to use a high-light transmissive material, such as urea-formaldehyde resin, melamine-formaldehyde resin,
20 polyester, polyurethane, polyamide, polyethylene, polystyrene, polyvinyl alcohol, gelatin or their copolymers. A method of disposing the microcapsule 10 on the first substrate 1 is not particularly limited but may be an ink jet method using nozzles.

25 Hereinbelow, an electrophoretic display device using an electrophoretic dispersion liquid according to Second Embodiment of the present invention will be

described.

Figure 4 is a sectional view of the electrophoretic display device, wherein the same reference numerals as in Figure 1 represent members or
5 means identical or corresponding to those shown in Figure 1.

As shown in Figure 4, the electrophoretic display device includes a first substrate 21 on which a first electrode 4 and a second electrode 5 are
10 disposed. Between the electrodes 4 and 5 and on the second electrode 5, an insulating layer 9a and an insulating layer 9b are formed, respectively. The insulating layer 9a formed between the electrodes 4 and 5 may be colored or may be colorless and
15 transparent, but the insulating layer 9b for electrically insulating the second electrode 5 is colorless and transparent.

The electrophoretic display device further includes a second substrate 22 disposed opposite to
20 the first substrate 21 with a spacing through a partition wall 3. In a cell (space) defined by the pair of first and second substrates 21 and 22 and the partition wall 3, an electrophoretic dispersion liquid 8 comprising electrophoretic particles 6, an
25 electrophoretic dispersion medium and a polymer is sealed. A display surface of the electrophoretic display device is located on the second substrate 22

side.

The second electrode 5 comprises a plurality of electrode portions as pixel electrodes and the first electrode 4 is a common electrode. The
5 electrophoretic particles 6 in each individual cell are controlled by an electric field applied through the second electrode 5, so that at each pixel, the color (e.g., black) of the electrophoretic particles 6 or the color (e.g., white) of the insulating layer 9a
10 can be selectively displayed.

The first substrate 21 is an arbitrary insulating member for supporting the electrophoretic display device and may be formed of glass or plastics. The second substrate 22 may be a transparent substrate
15 or a transparent plastic substrate.

The first electrode 4 is a metal electrode of, e.g., Al exhibiting light reflection performance.

The insulating layer 9a formed on the first electrode 4 is formed of a mixture of a transparent
20 colorless insulating resin with light scattering fine particles of, e.g., aluminum oxide or titanium oxide. As a material for the transparent colorless insulating resin, it is possible use the above described insulating resins. Incidentally, it is also possible
25 to use a light scattering method utilizing unevenness at the surface of the metal electrode without using the fine particles.

The second electrode 5 is formed of an electroconductive material, which looks dark black from the viewer side of the electrophoretic display device, such as titanium carbide, black-treated Cr, and Al or Ti provided with a black surface layer. Pattern formation of the second electrode 5 may be performed through a photolithographic process.

On the second electrode 5, the insulating layer 9b is formed of, e.g., the transparent colorless insulating resin described above.

In this embodiment, a display contrast is largely depend on an areal ratio between the second electrode 5 (each electrode portion) and an associated pixel, so that an exposed area of the second electrode 5 is required to be smaller than that of the pixel in order to enhance a contrast. For this reason, it is preferable that the areal ratio therebetween may ordinarily be 1:2 to 1:5.

As the electrophoretic dispersion medium, it is possible to use the above described liquids, and as the electrophoretic particles, it is possible to use the above described particles. Further, as the polymer, it is possible to use the acidic polymers or the basic polymers described above.

Next, a display operation of the electrophoretic display device using the electrophoretic dispersion liquid according to this

embodiment will be described.

Figures 5(a) and 5(b) illustrate a display example wherein, e.g., an electrophoretic dispersion liquid 8 comprising black electrophoretic particles 6 surface-modified with an acidic group, a colorless and transparent electrophoretic dispersion medium, and a basic polymer is filled in a cell. The electrophoretic particles 6 surface-modified with the acidic group is negatively charged by the acid-base interaction with the basic polymer.

In the case where the color of the surface of the insulating layer 9a is white and the color of the surface of the second electrode 5 is black, when the electrophoretic particles 6 are collected on the surface of the second electrode 5 as shown in Figure 5(a), it is possible to effect white display. On the other hand, when the electrophoretic particles 6 are collected on the surface of the insulating layer 9b (on the insulating layer 9a and the first electrode 4) as shown in Figure 5(b), it is possible to effect black display. By performing such a drive pixel by pixel, it is possible to display an arbitrary image or character by use of a multiplicity of pixels.

As described above, as the acidic or basic polymer for impairing the chargeability and the dispersibility to the electrophoretic particles 6, the basic polymer having the acidic or basic group which

is not precipitated in the electrophoretic dispersion medium at least in the low temperature environment of -20 to 0 °C is used. As a result, it is possible to provide an electrophoretic dispersion liquid 8 with
5 reliability without causing deterioration in display quality even in the low temperature environment and an electrophoretic display device using the electrophoretic dispersion liquid 8.

In the above embodiment, the electrophoretic
10 display device having such a structure that the electrophoretic dispersion liquid 8 is filled in the cell is described but an electrophoretic display device having such a structure, as shown in Figure 6, that microcapsules 10 each containing therein
15 electrophoretic particles 6 and an electrophoretic dispersion liquid 8 is disposed in place of the cell between a first substrate 1 and a second substrate 2. In the case of using such microcapsules 10, an insulating layer (9a and/or 9b shown in Figures 5(a)
20 and 5(b)) may be omitted.

By controlling the electrophoretic particles in each microcapsule 10 under application of an electric field through a second electrode 5, it is possible to effect display of an arbitrary image or
25 character.

The microcapsule 10 can be prepared by the above described method. A method of disposing the

microcapsule 10 on the first substrate 1 is not particularly limited but may be an ink jet method using nozzles.

Hereinbelow, the present invention will be
5 described more specifically based on Examples as specific examples of First and Second Embodiments described above.

(Example 1)

A uniform mixture liquid was prepared by
10 mixing titanium oxide which was subjected to hydrophobicity-imparting treatment, and azobis-isobutyronitrile (AIBN) (polymerization initiator) in hexadecyl methacrylate. In a dispersion medium comprising a sodium dodecyl sulfonate aqueous solution
15 and calcium phosphate dispersed therein, the uniform mixture liquid was added. The resultant liquid was stirred at 10,000 rpm for 15 minutes by a homogenizer to prepare a suspension. Thereafter, the suspension was subjected to polymerization at 80 °C for 7 hours
20 in a nitrogen atmosphere. After the polymerization, the resultant polymer particles were washed with hydrochloric acid and then with water, followed by drying and classification to obtain white electrophoretic particles each comprising titanium
25 oxide particle coated with polyhexadecyl methacrylate. An average particle size of the electrophoretic particles was about 2 microns.

Then, 5 wt. % of the white electrophoretic particles (modified with the basic group), 2 wt. % of an acidic polymer 8 (polyisoprene-graft-monomethyl maleate; liquid polymer having a number-average
5 molecular weight of 25,000; the number of acidic group per one molecule: about 10), and 93 wt. % of an electrophoretic dispersion medium comprising isoparaffin (trade name: "Isopar H", mfd. by Exxon Corp.) and 0.1 wt. % of a colorant ("Oil Blue N", mfd.
10 by Aldrich Co.) dissolved therein, were mixed to Aldrich Co.) dissolved therein, were mixed to prepare an electrophoretic dispersion liquid. The electrophoretic dispersion liquid was injected into a cell by using nozzles according to an ink jet method
15 to provide an electrophoretic display device, as shown in Figure 1, which was connected with a voltage application circuit.

When the resultant electrophoretic display device was subjected to blue/white contrast display in
20 a low temperature environment of -20°C to 0°C , it was possible to effect clear blue/white display. Further, during the display operation, the acidic polymer imparted a positive chargeability and a dispersibility to the electrophoretic particles 6 and
25 was not precipitated in the electrophoretic dispersion medium.

According to this example, it was confirmed

that the resultant electrophoretic display device which was not deteriorated in electrophoretic display quality even in the low temperature environment.

(Example 2)

5 A plurality of microcapsules each containing an electrophoretic dispersion liquid identical to that used in Example 1 were prepared by in-situ polymerization method. Each microcapsule was formed of urea-formaldehyde resin as a film-forming material. An
10 electrophoretic display device shown in Figure 3 was prepared by disposing the plurality of microcapsules on a first substrate 1 by use of nozzles according to the ink jet method. The electrophoretic display device was connected with a voltage application circuit.

15 When the resultant electrophoretic display device was subjected to blue/white contrast display in a low temperature environment of -20 °C to 0 °C, it was possible to effect clear blue/white display. Further, during the display operation, the acidic
20 polymer imparted a positive chargeability and a dispersibility to the electrophoretic particles 6 and was not precipitated in the electrophoretic dispersion medium.

 According to this example, it was confirmed
25 that the resultant electrophoretic display device which was not deteriorated in electrophoretic display quality even in the low temperature environment.

(Example 3)

One wt. % of acidic carbon black (pH = 3; average particle size = 26 nm), 0.7 wt. % of a basic polymer 8

5 (polybutadiene-graft-N-(3-aminopropyl)(meth)acrylate; liquid polymer having a number-average molecular weight of 30,000; the number of acidic group per one molecule: about 12), and 98.3 wt. % of an

electrophoretic dispersion medium of isoparaffin

10 (trade name: "Isopar H", mfd. by Exxon Corp.), were mixed to Aldrich Co.) dissolved therein, were mixed to prepare an electrophoretic dispersion liquid. The electrophoretic dispersion liquid was injected into a cell by using nozzles according to an ink jet method

15 to provide an electrophoretic display device, as shown in Figure 4, which was connected with a voltage application circuit.

When the resultant electrophoretic display device was subjected to black/white contrast display

20 in a low temperature environment of -20 °C to 0 °C, it was possible to effect clear black/white display. Further, during the display operation, the basic polymer imparted a negative chargeability and a dispersibility to the electrophoretic particles 6 and

25 was not precipitated in the electrophoretic dispersion medium.

According to this example, it was confirmed

that the resultant electrophoretic display device which was not deteriorated in electrophoretic display quality even in the low temperature environment.

(Example 4)

5 A plurality of microcapsules each containing an electrophoretic dispersion liquid identical to that used in Example 3 were prepared by interfacial polymerization method. Each microcapsule was formed of polyamide resin as a film-forming material. An
10 electrophoretic display device shown in Figure 6 was prepared by disposing the plurality of microcapsules 10 on a first substrate 1 by use of nozzles according to the ink jet method. The electrophoretic display device was connected with a voltage application
15 circuit.

 When the resultant electrophoretic display device was subjected to black/white contrast display in a low temperature environment of -20 °C to 0 °C, it was possible to effect clear black/white display.
20 Further, during the display operation, the basic polymer imparted a negative chargeability and a dispersibility to the electrophoretic particles 6 and was not precipitated in the electrophoretic dispersion medium.

25 According to this example, it was confirmed that the resultant electrophoretic display device which was not deteriorated in electrophoretic display

quality even in the low temperature environment.

[INDUSTRIAL APPLICABILITY]

As described hereinabove, according to the
5 present invention, it is possible to provide an
electrophoretic dispersion liquid for an
electrophoretic display device capable of displaying
desired image and character with reliability without
causing a deterioration of display performance even in
10 a low temperature environment (e.g., from 0 °C to
-20 °C). The present invention further provides a
display apparatus using such an electrophoretic
dispersion liquid.

CLAIMS

1. An electrophoretic dispersion liquid for an
5 electrophoretic display apparatus, comprising:
a plurality of electrophoretic particles each
surface of which is modified by one of a basic group
and an acidic group,
a liquid for holding said electrophoretic
10 particles to be dispersed therein, and
a polydiene, having the other group, dissolved
in said liquid.
2. A liquid according to claim 1, wherein said
15 polydiene is a graft polydiene having a grafted acidic
group or a grafted basic group.
3. A liquid according to Claim 1 or 2, wherein
said polydiene is a polybutadiene.
- 20
4. A liquid according to Claim 1 or 2, wherein
said polydiene is a polyisoprene.
5. A liquid according to Claim 1, wherein said
25 polydiene has an average molecular weight of
1,000 - 100,000.

6. A liquid according to Claim 1, wherein said polydiene has 1 - 50 acidic groups or basic groups per one molecule.

5 7. A liquid according to Claim 1, wherein said electrophoretic dispersion liquid contains said polydiene in an amount which is 0.01 to 3 times a weight of said electrophoretic particles.

10 8. A liquid according to Claim 1, wherein said polydiene is dissolved in said liquid in a temperature range of -20 to 0 °C.

15 9. A liquid according to Claim 1, wherein said liquid is a nonpolar solvent.

10. A display apparatus, comprising:
an electrophoretic dispersion liquid which comprises a plurality of electrophoretic particles
20 each surface of which is modified by one of a basic group and an acidic group, a liquid for holding said electrophoretic particles to be dispersed therein, and a polydiene, having the other group, dissolved in said liquid;
25 a closed cell for holding said electrophoretic dispersion liquid, and
a first electrode and a second electrode for

generating an electric field in said closed cell, said electric field being a voltage of a polarity which is alternately changed is applied between said first and second electrodes and moving said electrophoretic
5 particles.

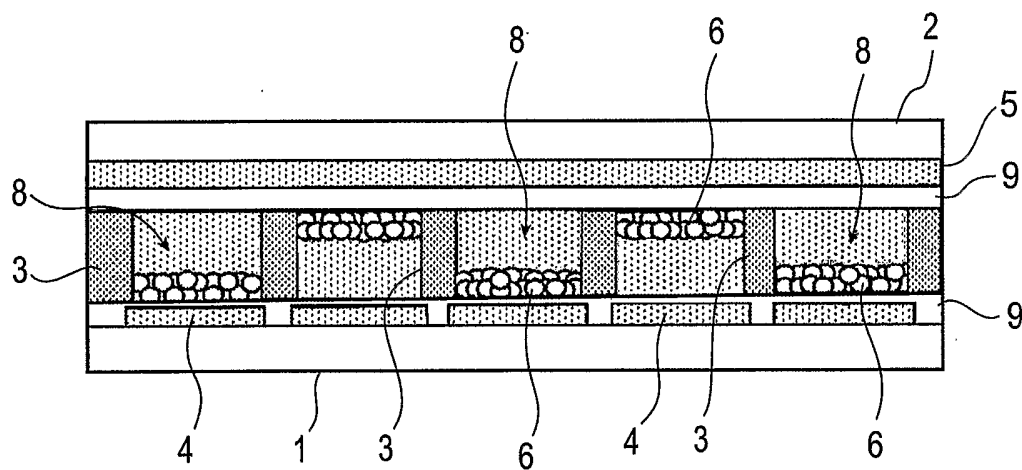

FIG. 1

2/5

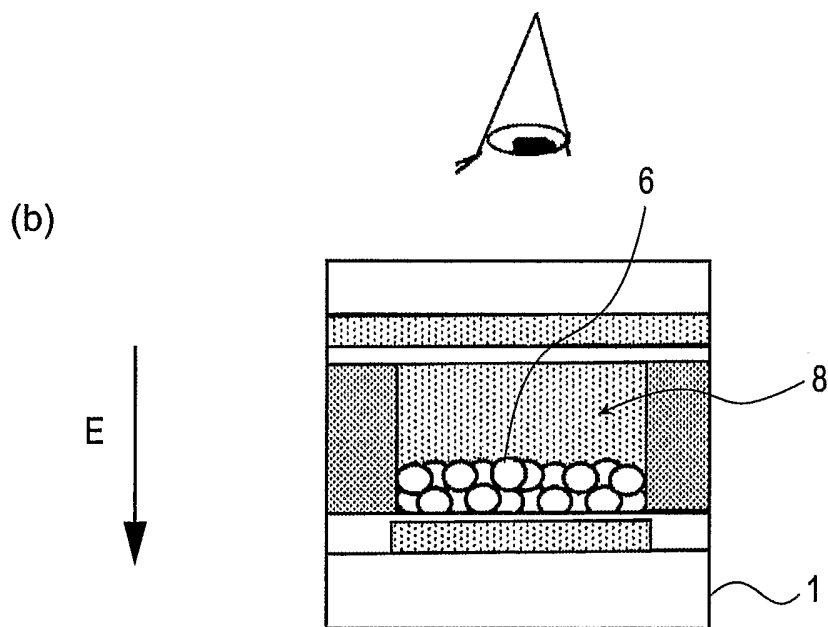
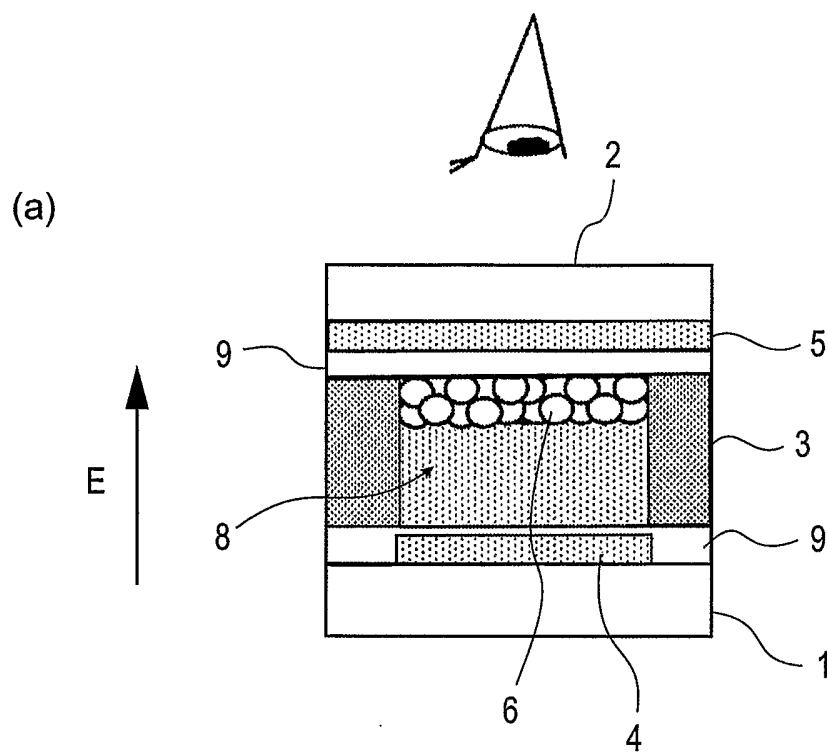

FIG.2

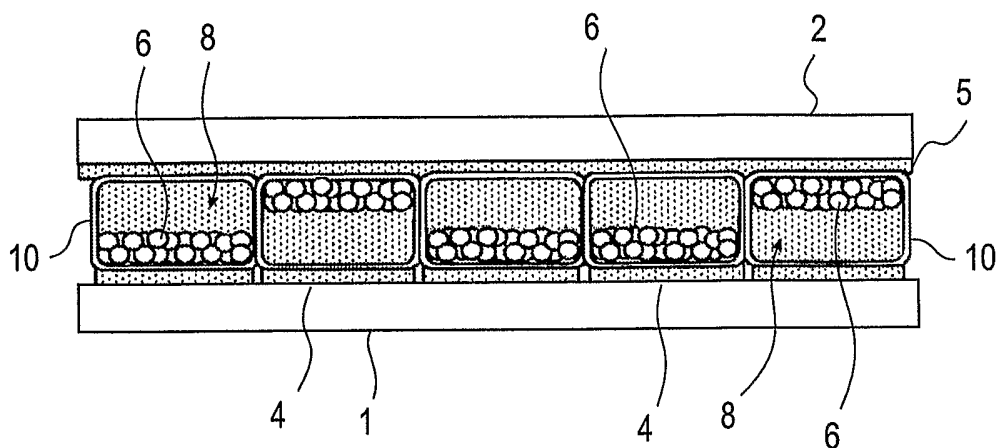

FIG.3

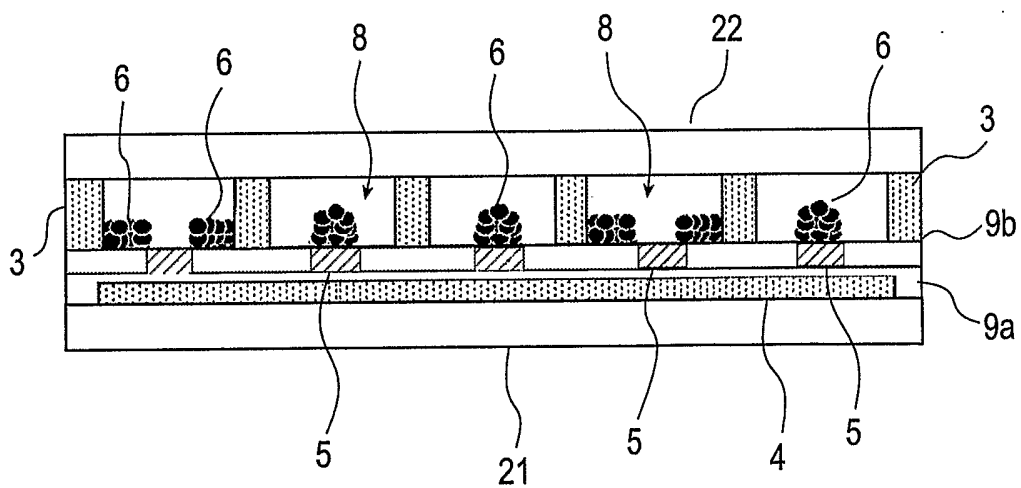

FIG.4

4/5

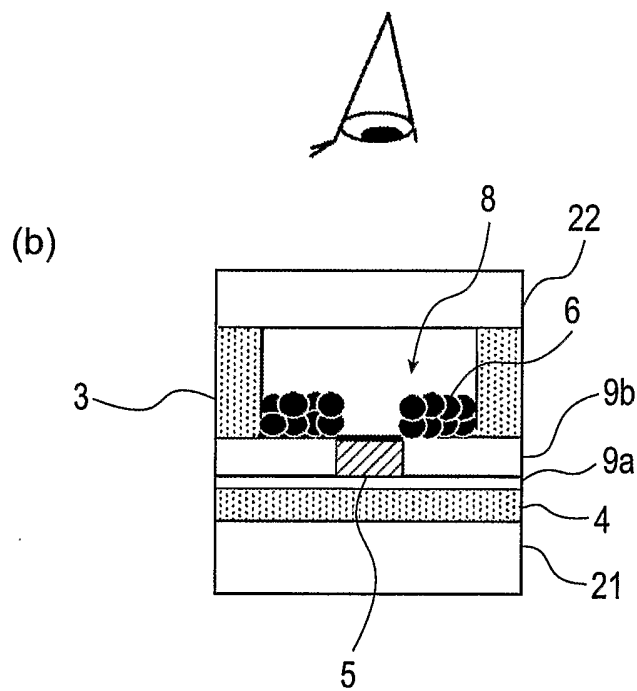
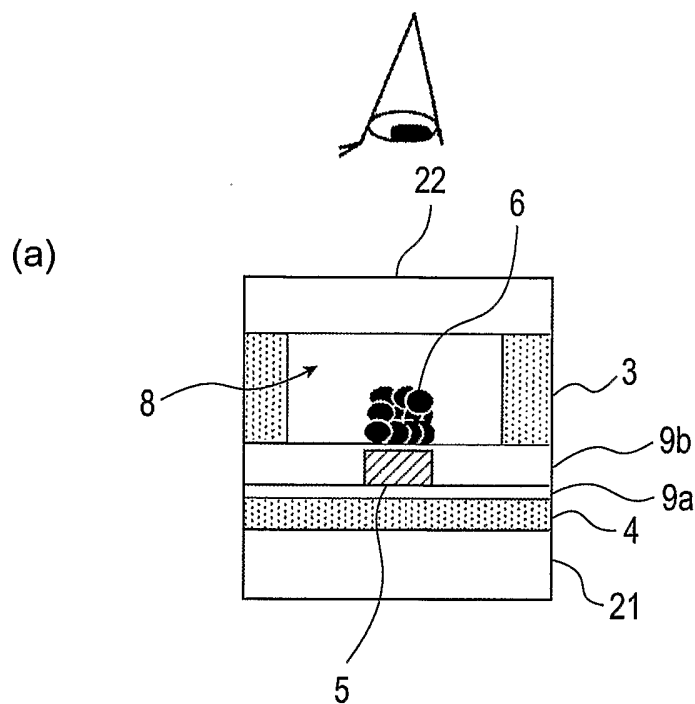

FIG. 5

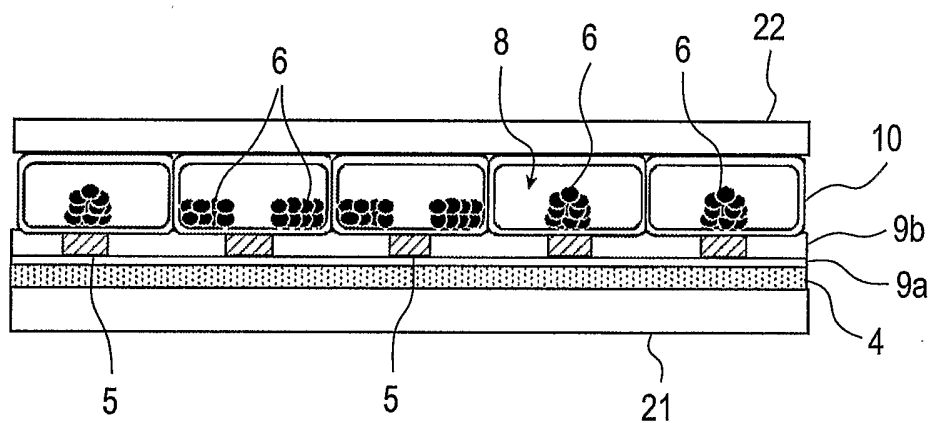

FIG.6

INTERNATIONAL SEARCH REPORT

International Application No
PCT/JP2004/014699

A. CLASSIFICATION OF SUBJECT MATTER IPC 7 G02F1/167 G02B26/02 C09D5/44				
According to International Patent Classification (IPC) or to both national classification and IPC				
B. FIELDS SEARCHED Minimum documentation searched (classification system followed by classification symbols) IPC 7 G02F G02B C09D				
Documentation searched other than minimum documentation to the extent that such documents are included in the fields searched				
Electronic data base consulted during the international search (name of data base and, where practical, search terms used) EPO-Internal, WPI Data, PAJ, INSPEC, COMPENDEX, IBM-TDB				
C. DOCUMENTS CONSIDERED TO BE RELEVANT				
Category °	Citation of document, with indication, where appropriate, of the relevant passages	Relevant to claim No.		
X	US 5 914 806 A (GORDON II JOSEPH GROVER ET AL) 22 June 1999 (1999-06-22) abstract figures 1,2 column 1, line 50 - line 60 column 2, line 6 - column 5, line 37 column 5, line 45 - column 6, line 49	1-10		
A	CHENG T-L ET AL: "Spherulites of cis-1,4-polybutadiene: molecular weight effects" POLYMER, ELSEVIER SCIENCE PUBLISHERS B.V, GB, vol. 36, no. 1, 1995, pages 73-80, XP004026014 ISSN: 0032-3861 page 73 - page 75	5,8		
<table style="width: 100%; border: none;"> <tr> <td style="width: 50%; border: none;"><input checked="" type="checkbox"/> Further documents are listed in the continuation of box C.</td> <td style="width: 50%; border: none;"><input checked="" type="checkbox"/> Patent family members are listed in annex.</td> </tr> </table>			<input checked="" type="checkbox"/> Further documents are listed in the continuation of box C.	<input checked="" type="checkbox"/> Patent family members are listed in annex.
<input checked="" type="checkbox"/> Further documents are listed in the continuation of box C.	<input checked="" type="checkbox"/> Patent family members are listed in annex.			
° Special categories of cited documents :				
A document defining the general state of the art which is not considered to be of particular relevance *E* earlier document but published on or after the international filing date *L* document which may throw doubts on priority claim(s) or which is cited to establish the publication date of another citation or other special reason (as specified) *O* document referring to an oral disclosure, use, exhibition or other means *P* document published prior to the international filing date but later than the priority date claimed	*T* later document published after the international filing date or priority date and not in conflict with the application but cited to understand the principle or theory underlying the invention *X* document of particular relevance; the claimed invention cannot be considered novel or cannot be considered to involve an inventive step when the document is taken alone *Y* document of particular relevance; the claimed invention cannot be considered to involve an inventive step when the document is combined with one or more other such documents, such combination being obvious to a person skilled in the art. *&* document member of the same patent family			
Date of the actual completion of the international search	Date of mailing of the international search report			
24 November 2004	03/12/2004			
Name and mailing address of the ISA European Patent Office, P.B. 5818 Patentlaan 2 NL - 2280 HV Rijswijk Tel. (+31-70) 340-2040, Tx. 31 651 epo nl, Fax: (+31-70) 340-3016	Authorized officer Kentischer, F			

INTERNATIONAL SEARCH REPORT

International Application No
PCT/JP2004/014699

C.(Continuation) DOCUMENTS CONSIDERED TO BE RELEVANT		
Category °	Citation of document, with indication, where appropriate, of the relevant passages	Relevant to claim No.
A	US 2002/027701 A1 (YANAGISAWA MASAHIRO ET AL) 7 March 2002 (2002-03-07) cited in the application abstract figures 1,2a-2c,3 paragraphs '0019!, '0032!, '0036! - '0038!, '0047! - '0061! -----	1,9,10
A	US 5 380 362 A (SCHUBERT FREDERIC E) 10 January 1995 (1995-01-10) cited in the application abstract -----	1,9,10
A	US 2002/146572 A1 (YANAGISAWA MASAHIRO) 10 October 2002 (2002-10-10) abstract figures 1,2a-2c,3 paragraphs '0012!, '0016!, '0022!, '0026!, '0027!, '0044!, '0045!, '0048!, '0049! -----	1,9,10
A	US 6 017 584 A (ALBERT JONATHAN D ET AL) 25 January 2000 (2000-01-25) abstract figure 1 column 6, line 10 - column 9, line 30 column 12, line 45 - column 15, line 9 -----	1,10
A	PATENT ABSTRACTS OF JAPAN vol. 009, no. 078 (C-274), 6 April 1985 (1985-04-06) -& JP 59 213428 A (RICOH KK), 3 December 1984 (1984-12-03) abstract -----	1,9

INTERNATIONAL SEARCH REPORT

Information on patent family members

International Application No

PCT/JP2004/014699

Patent document cited in search report	Publication date	Patent family member(s)	Publication date
US 5914806	A	22-06-1999	NONE
US 2002027701	A1	07-03-2002	JP 2002062545 A
US 5380362	A	10-01-1995	CA 2165068 A1 26-01-1995 DE 69424170 D1 31-05-2000 DE 69424170 T2 21-12-2000 EP 0708798 A1 01-05-1996 JP 9500458 T 14-01-1997 WO 9502636 A1 26-01-1995
US 2002146572	A1	10-10-2002	JP 2002338642 A
US 6017584	A	25-01-2000	US 6124851 A 26-09-2000 US 6120588 A 19-09-2000 AU 6504296 A 18-02-1997 EP 0839356 A2 06-05-1998 JP 11502950 T 09-03-1999 JP 2002221918 A 09-08-2002 WO 9704398 A2 06-02-1997 US 6515649 B1 04-02-2003 US 6120839 A 19-09-2000 US 6727881 B1 27-04-2004 US 6118426 A 12-09-2000 US 6710540 B1 23-03-2004 US 6639578 B1 28-10-2003 US 6262706 B1 17-07-2001 US 6459418 B1 01-10-2002 US 6664944 B1 16-12-2003 US 6680725 B1 20-01-2004 US 2003112491 A1 19-06-2003 US 6249271 B1 19-06-2001 US 2004136048 A1 15-07-2004 US 2004090415 A1 13-05-2004 US 2004113884 A1 17-06-2004 AT 280963 T 15-11-2004 AU 9122598 A 16-03-1999 AU 9206398 A 16-03-1999 AU 9207898 A 16-03-1999 CA 2300827 A1 04-03-1999 CA 2300830 A1 04-03-1999 CA 2300849 A1 04-03-1999 DE 69814410 D1 12-06-2003 EP 1335211 A2 13-08-2003 EP 1010035 A1 21-06-2000 EP 1010036 A1 21-06-2000 EP 1010037 A1 21-06-2000 JP 2004500583 T 08-01-2004 JP 2002504696 T 12-02-2002 JP 2004500584 T 08-01-2004 US 2002145792 A1 10-10-2002 US 2003096113 A1 22-05-2003 WO 9910767 A1 04-03-1999 WO 9910768 A1 04-03-1999 WO 9910769 A1 04-03-1999 US 2003037702 A1 27-02-2003 US 6422687 B1 23-07-2002 US 6323989 B1 27-11-2001

INTERNATIONAL SEARCH REPORT

Information on patent family members

International Application No

PCT/JP2004/014699

Patent document cited in search report	Publication date	Patent family member(s)	Publication date
US 6017584	A	US 2004054031 A1	18-03-2004
		BR 9814454 A	03-10-2000
		BR 9814455 A	03-10-2000
		BR 9814456 A	03-10-2000
		DE 69814410 T2	27-11-2003
JP 59213428	A	JP 8023005 B	06-03-1996