



US00RE47662E

(19) **United States**  
(12) **Reissued Patent**  
**Liu et al.**

(10) **Patent Number:** **US RE47,662 E**  
(45) **Date of Reissued Patent:** **Oct. 22, 2019**

(54) **SYSTEM AND METHOD FOR PUCCH SUBBAND FEEDBACK SIGNALING IN A WIRELESS NETWORK**

(56) **References Cited**

U.S. PATENT DOCUMENTS

(71) Applicant: **Samsung Electronics Co., Ltd.**,  
Suwon-si, Gyeonggi-do (KR)  
(72) Inventors: **Lingjia Liu**, Allen, TX (US);  
**Jianzhong Zhang**, Plano, TX (US)  
(73) Assignee: **Samsung Electronics Co., Ltd.**,  
Suwon-si (KR)

2007/0026813 A1 2/2007 Khan  
2009/0181691 A1 7/2009 Kotecha et al.  
2009/0207784 A1 8/2009 Lee et al.  
2009/0257383 A1 10/2009 Lee et al.  
2010/0002664 A1 1/2010 Pan et al.  
2010/0091892 A1 4/2010 Gorokhov  
2010/0135230 A1 6/2010 Baker et al.

(Continued)

FOREIGN PATENT DOCUMENTS

(21) Appl. No.: **14/951,255**  
(22) Filed: **Nov. 24, 2015**

CN 101669314 A 3/2010  
CN 102934370 A 2/2013

(Continued)

**Related U.S. Patent Documents**

OTHER PUBLICATIONS

Reissue of:

(64) Patent No.: **9,042,841**  
Issued: **May 26, 2015**  
Appl. No.: **13/231,710**  
Filed: **Sep. 13, 2011**

3GPP TSG-RAN Meeting #62 Madrid, Spain, Aug. 23-27, 2010.\*  
(Continued)

*Primary Examiner* — Minh Dieu Nguyen

U.S. Applications:

(60) Provisional application No. 61/384,156, filed on Sep. 17, 2010.

(57) **ABSTRACT**

(51) **Int. Cl.**  
**H04L 1/00** (2006.01)  
**H04B 7/06** (2006.01)

A mobile station for use in a wireless network. The mobile station transmits feedback reports to a base station of the wireless network. The feedback reports comprise a first feedback report, a second feedback report and a third feedback report. The first feedback report includes a pre-coder type indication (PTI) value that indicates at least one of a period of the second feedback report and a period of the third feedback report. The PTI value indicates a ratio of the third feedback report period to the second feedback report period. The PTI value also indicates the selected feedback information contained in the second feedback report and the third feedback report.

(52) **U.S. Cl.**  
CPC ..... **H04L 1/0027** (2013.01); **H04B 7/0623**  
(2013.01); **H04B 7/0636** (2013.01); **H04L**  
**1/0031** (2013.01)

(58) **Field of Classification Search**  
CPC ..... H04B 7/18528; H04B 7/18571; H04B  
7/18576; H04W 84/06

See application file for complete search history.

**34 Claims, 4 Drawing Sheets**

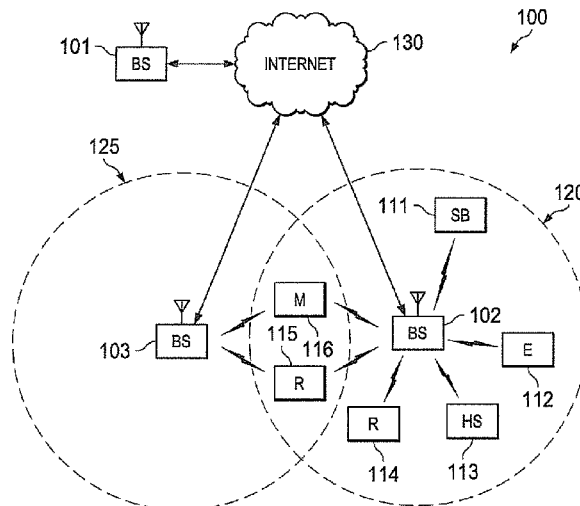

(56)

**References Cited**

U.S. PATENT DOCUMENTS

2012/0063500	A1*	3/2012	Wang et al. ....	375/224
2013/0028225	A1*	1/2013	Ko et al. ....	370/329
2015/0124707	A1	5/2015	Wang et al.	

FOREIGN PATENT DOCUMENTS

CN	103229578	A	7/2013
EP	1750408	A2	2/2007
EP	2560296	A2	2/2013
EP	2560297	A2	2/2013
EP	2560298	A2	2/2013
RU	2363104	C1	7/2009
WO	WO 2012/037335	A1	3/2012

OTHER PUBLICATIONS

Notification of Reasons for Rejection dated Jun. 13, 2016 in connection with Japanese Application No. 2015-186600, 7 pages.  
 Alcatel-Lucent, et al., "Way Forward on CSI Feedback for Rel. 10 DL MIMO", 3GPP TSG RAN WG1 62, R1-104476, Madrid, Spain, Aug. 23-27, 2010, 5 pages.  
 Office Action dated Sep. 5, 2016 in connection with Japanese Application No. 2015-186599, 6 pages.  
 Motorola, "Proposal for 4Tx and 8 Tx Codebooks and Signaling", 3GPP TSG RAN WG1 #62, R1-104686, Madrid, Spain, Aug. 23-27, 2010, 6 pages.  
 ZTE, "Further Design Refinement and Performance Evaluation of 2-Level Codebook for 4Tx LTE-A DL MIMO", 3GPP TSG RAN WG1 Meeting #62, 9 pages.

3GPP TSG RAN WG1 G2; "Way Forward on CSI Feedback for Rel.10 DL MIMO" Madrid, Spain; XP050598649; Aug. 23-27, 2010; Alcatel-Lucent; 6 pages.  
 3GPP TSG RAN WG1 G2; "Way Forward on CSI Feedback for Rel.10 DL MIMO" Madrid, Spain; XP050598692; Aug. 23-27, 2010; Alcatel-Lucent; 5 pages.  
 First Office Action regarding Chinese Patent Application No. 201510623051.4, issued Nov. 1, 2017, 14 pages.  
 Foreign Communication from Related Counterpart Application; Chinese Patent Application No. 201510622671.6; First Office Action dated Feb. 27, 2018; 14 pages.  
 Communication from a foreign patent office in a counterpart foreign application, Government of India, Examination report for Application No. IN 3725/KOLNP/2012, May 11, 2018, 7 pages.  
 Communication from a foreign patent office in a counterpart foreign application, State Intellectual Property Office for the People's Republic of China, "The Second Office Action," Application No. CN 2015106230514, Jun. 26, 2018, 12 pages.  
 Alcatel-Lucent, et al., "Way Forward on CSI Feedback for Rel.10 DL MIMO," R1-105067 (R1-104476), 3GPP TSG RAN WG1 62, Madrid, Spain, Aug. 23-27, 2010, 5 pages.  
 Decision on Grant regarding Russian Patent Application No. 2015139082, dated Mar. 6, 2019, 23 pages.  
 European Search Report dated Jul. 17, 2013 in connection with European Patent Application No. 11181656.7, 11 pages.  
 3GPP TSG-RAN Meeting #62; "Introduction of Rel-10 LTE-Advanced features in 36.212" R1-105097; Madrid, Spain, Aug. 23-27, 2010; 86 pages.  
 3GPP TSG-RAN Meeting #62; Introduction of Rel-10 LTE-Advanced features in 36.213 R1-105111; Madrid, Spain, Aug. 23-27, 2010; 81 pages.  
 International Search Report dated Feb. 24, 2012 in connection with International Patent Application No. PCT/KR2011/006868.

\* cited by examiner

FIG. 1

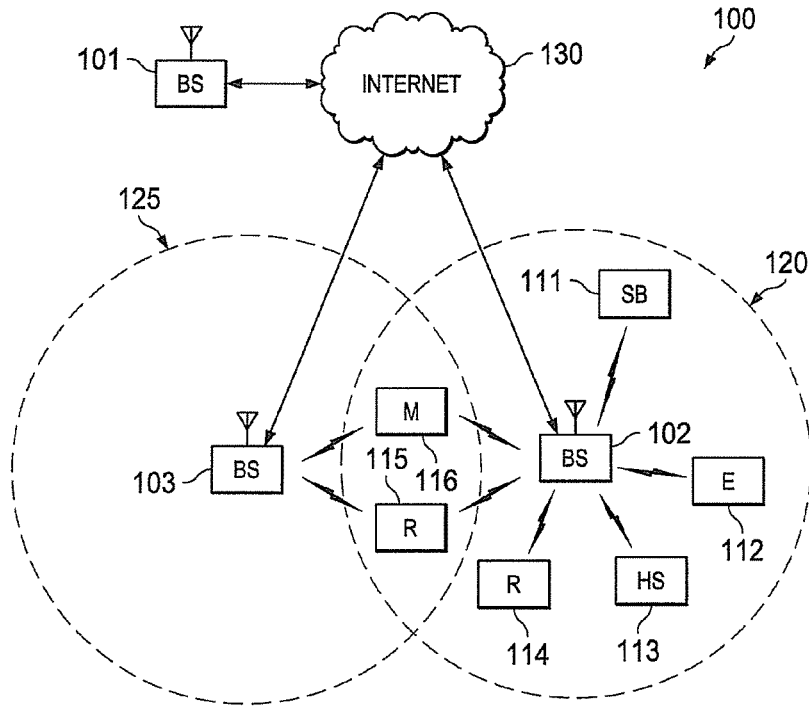
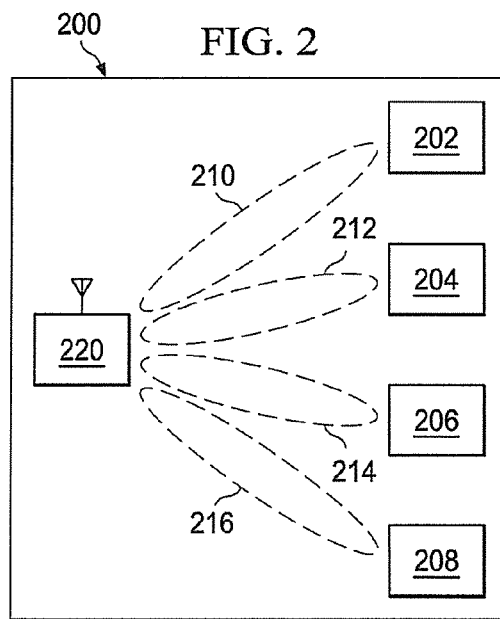

FIG. 2



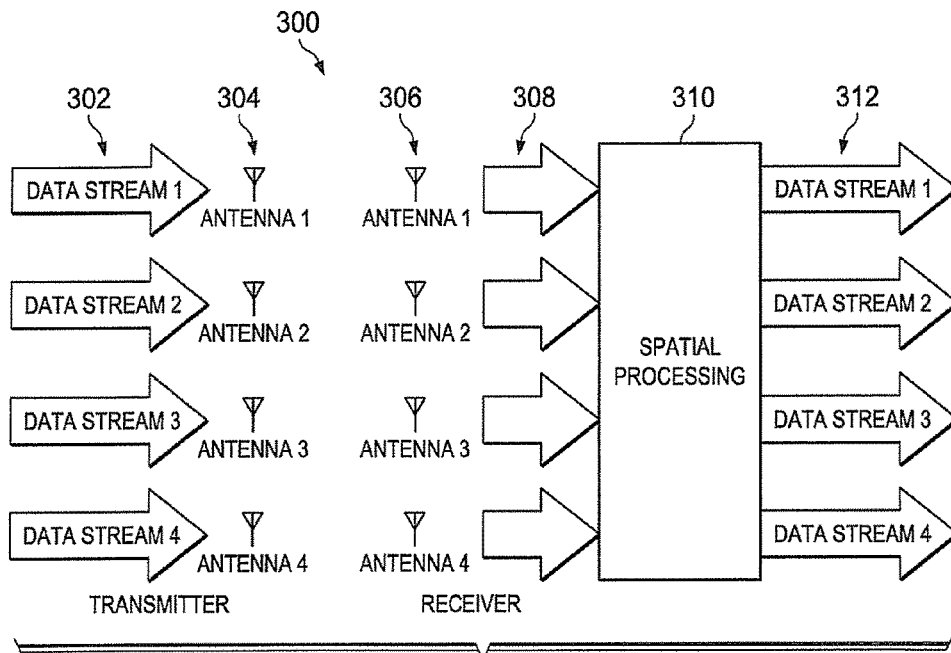

FIG. 3

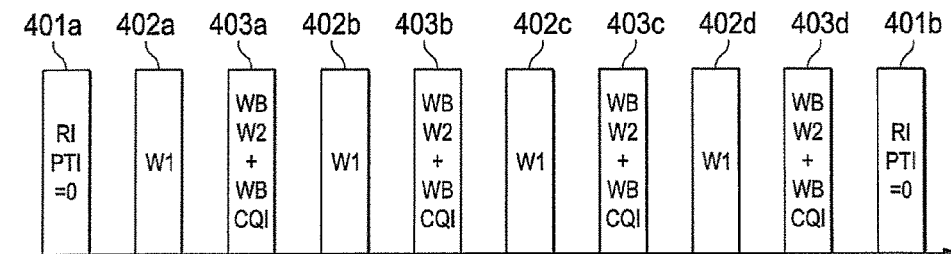

FIG. 4

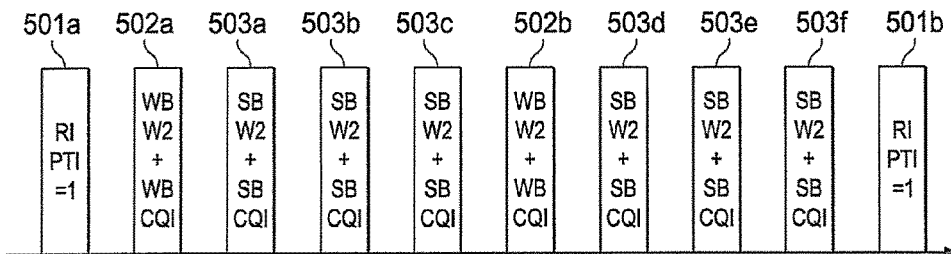

FIG. 5

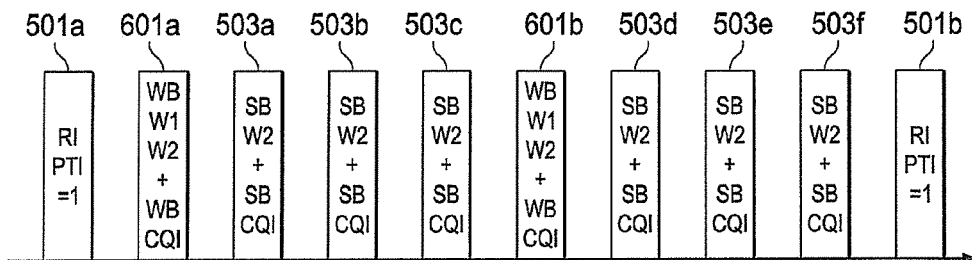

FIG. 6

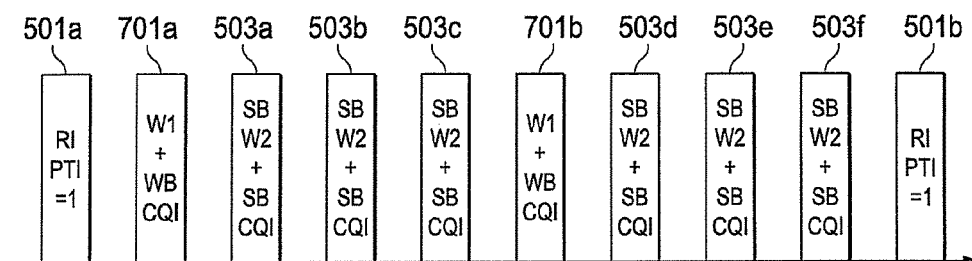

FIG. 7

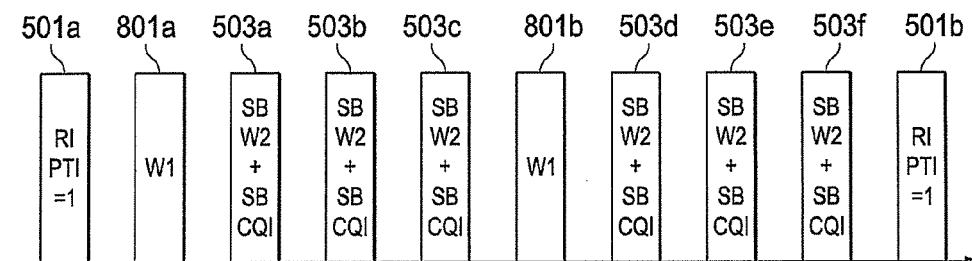

FIG. 8

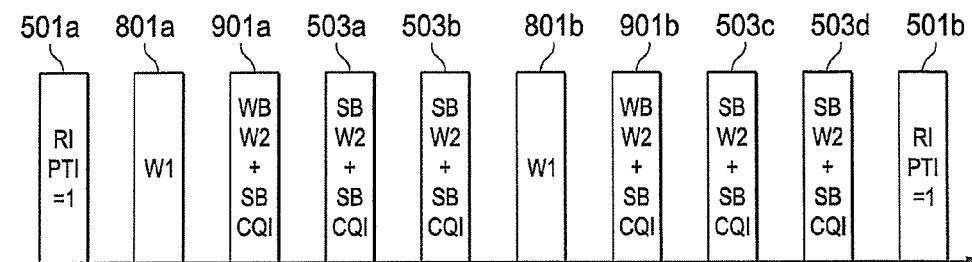

FIG. 9

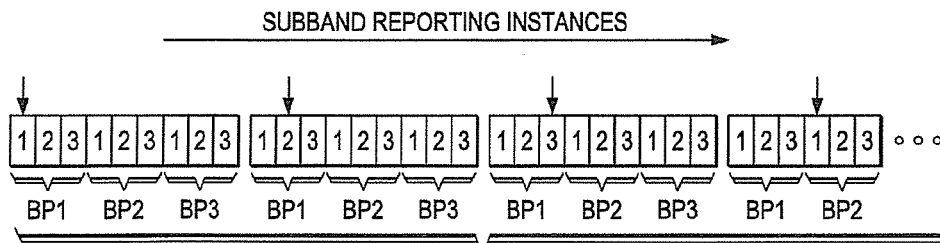

FIG. 10

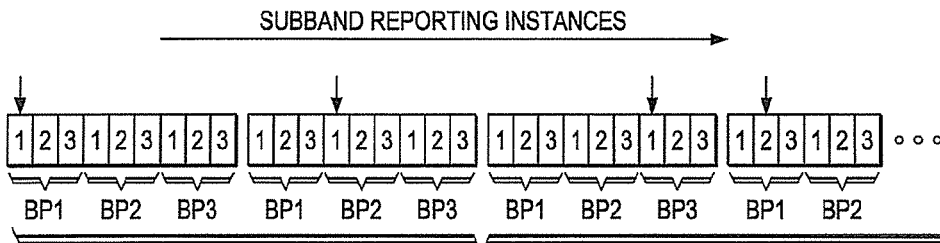

FIG. 11

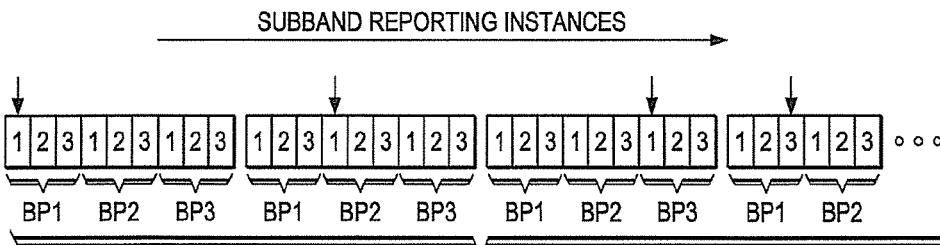

FIG. 12

**SYSTEM AND METHOD FOR PUCCH  
SUBBAND FEEDBACK SIGNALING IN A  
WIRELESS NETWORK**

**Matter enclosed in heavy brackets [ ] appears in the original patent but forms no part of this reissue specification; matter printed in italics indicates the additions made by reissue; a claim printed with strikethrough indicates that the claim was canceled, disclaimed, or held invalid by a prior post-patent action or proceeding.**

CROSS-REFERENCE TO RELATED  
APPLICATION(S) AND CLAIM OF PRIORITY

The present application is [related to] *one of two applications for reissue of U.S. Pat. No. 9,042,841, which is also the subject of co-pending U.S. patent Reissue application Ser. No. 15/422,423 filed Feb. 2, 2017, which is a divisional of this application. U.S. Pat. No. 9,042,841 issued May 26, 2015 on U.S. Non-Provisional patent application Ser. No. 13/231,710 filed Sep. 13, 2011, and this application claims priority to that application as well as to the benefit under 35 U.S.C. § 119(e) of the filing date of U.S. Provisional Patent Application No. 61/384,156, filed Sep. 17, 2010, entitled "FEEDBACK SIGNALING DESIGN FOR PUCCH SUBBAND FEEDBACK". [Provisional Patent Application No. 61/384,156 is assigned to the assignee of the present application and] *The content of the above-identified patent documents is hereby incorporated by reference into the present application as if fully set forth herein. [The present application hereby claims priority under 35 U.S.C. §119(e) to U.S. Provisional Patent Application No. 61/384,156.]**

TECHNICAL FIELD

The present application relates generally to wireless networks and, more specifically, to feedback signaling for physical uplink control channel (PUCCH) subbands in Long Term Evolution Advanced (LTE-A) wireless systems.

BACKGROUND

In 3<sup>rd</sup> Generation Partnership Project Long Term Evolution (3GPP LTE), Orthogonal Frequency Division Multiplexing (OFDM) is adopted as a downlink (DL) transmission scheme.

The 3GPP LTE (Long Term Evolution) standard is the last stage in the realization of true 4th generation (4G) mobile telephone networks. Most major mobile carriers in the United States and several worldwide carriers have announced plans to convert their networks to LTE beginning in 2009. LTE is a set of enhancements to the Universal Mobile Telecommunications System (UMTS). Much of 3GPP Release 8 focuses on adopting 4G mobile communications technology, including an all-IP flat networking architecture.

The 3GPP LTE standard uses orthogonal frequency division multiplexing (OFDM) for the downlink (i.e., from the base station to the mobile station). Orthogonal frequency division multiplexing (OFDM) is a multi-carrier transmission technique that transmits on many orthogonal frequencies (or subcarriers). The orthogonal subcarriers are individually modulated and separated in frequency such that they do not interfere with one another. This provides high spectral efficiency and resistance to multipath effects.

The following documents and standards descriptions are hereby incorporated into the present disclosure as if fully set forth herein: 1) Document No. R1-101683, "Way Forward For Rel-10 Feedback Framework", February 2010; 2) Document No. R1-102579, "Way Forward On Release 10 Feedback", RAN WG1, April 2010; 3) Document No. R1-103419, "Way Forward on CSI Feedback Design For Rel-10 LD MIMO", May 2010; 4) Document No. R1-103332, "Way Forward On UE Feedback", May 2010; 5) Document No. R1-103333, "Refinements of Feedback And Codebook Design", May 2010; 6) Document No. R1-103805, "Double Codebook Performance Evaluation", June 2010; 7) Document No. R1-103701, "8Tx Codebook Design", June 2010; and 8) 3GPP Technical Specification No. 36.211.

In Release 10 LTE systems, a mobile station (or user equipment) performs feedback of precoder matrix index (PMI), rank indicator (RI), and channel quality indicator (CQI) to the base station (or eNodeB). In the 3GPP RAN1 #60 meeting, a way forward on feedback in Release 10 was agreed upon. Release 10 uses implicit feedback of precoder matrix index (PMI), rank indicator (RI), and channel quality indicator (CQI). The user equipment (UE) or mobile station (MS) spatial feedback for a subband represents a precoder and CQI is computed based on the assumption that the eNodeB or base station (BS) uses a specific precoder (or precoders), as given by the feedback, on each subband within the CQI reference resource. It is noted that a subband may correspond to the whole system bandwidth.

A precoder for a subband is composed of two matrices. The precoder structure is applied to all transmit (Tx) antenna array configurations. Each of the two matrices belongs to a separate codebook. The codebooks are known (or synchronized) at both the base station (eNodeB) and the mobile station (user equipment). Codebooks may or may not change over time for different subbands. The two codebook indices together determine the precoder. One of the two matrices targets the wideband or long-term channel properties. The other matrix targets the frequency-selective or short-term channel properties. It is noted that a matrix codebook in this context should be interpreted as a finite, enumerated set of matrices that, for each resource block (RB), is known to both the mobile station (or UE) and the base station (or eNodeB). It is also noted that a Release 8 precoder feedback may be deemed a special case of this structure.

Two messages are conveyed in this way: 1) Release 10 feedback will be based on implicit feedback similar to Release 8 feedback; and 2) two codebook indices will specify a precoder in Release 10, with one codebook targeting wideband and/or long-term channel properties and the other codebook targeting frequency-selective and/or short-term channel properties.

In the RAN1 #60 bis meeting, another way forward on mobile station (or UE) feedback in Release 10 was also agreed upon. A precoder,  $W$ , for a subband is a function of two matrices,  $W_1$  and  $W_2$ , (i.e., where  $W_1 \in C_1$  and  $W_2 \in C_2$ ).  $W_1$  is also referred to as a first PMI, and  $W_2$  is also referred to as a second PMI in this disclosure. The codebooks  $C_1$  and  $C_2$  are codebook 1 and codebook 2, respectively. The first PMI targets wideband (or long-term) channel properties. The second PMI targets frequency-selective (or short-term) channel properties. For the physical uplink control channel (PUCCH), the feedback corresponding to the first PMI and the second PMI may be sent in different or the same subframe, unless the payload is too large to send

the first PMI and the second PMI in the same subframe on PUCCH. Also, periodic and aperiodic reports are independent.

Thus, there is an important difference in feedback between Release 8 (Rel-8) and Release 10 (Rel-10) of 3GPP networks. In Release 8, only one codebook index specifies a precoder. However, in Release 10, two codebook indices specify a precoder. Furthermore, these two codebook indices in Release 10 may be sent in different subframes or in the same subframe.

In the RAN1 #62 bis meeting, a way forward on the signaling for Physical Uplink Control Channel (PUCCH) subband feedback was agreed upon. Specifically, three PUCCH feedback modes are agreed with two (2) candidates for the extension of Rel-8 PUCCH mode 1-1 and one (1) candidate for the extension of Rel-8 PUCCH mode 2-1.

More specifically, the candidate for the PUCCH subband feedback (extension of Rel-8 PUCCH mode 2-1) is as follows. A precoder,  $W$ , for a subband is determined from 3-subframe report conditioned upon the latest rank indicator (RI) report. The reporting format comprises 3 Reports. Report 1 includes RI and 1-bit precoder type indication (PTI). In Report 2, if  $PTI=0$ , then  $W1$  is reported. If  $PTI=1$ , then wideband CQI and wideband  $W2$  are reported. In Report 3, if  $PTI=0$ , then wideband CQI and wideband  $W2$  are reported. If  $PTI=1$ , then subband CQI and subband  $W2$  are reported. For 2 and 4 transmit (TS) antennas, the PTI value is assumed to be set to 1 and is not signaled.

Therefore, there is a need in the art for improved devices and methods for providing feedback information related to CQI, PMI, and RI in Rel-10 wireless networks. In particular, there is a need in the art for improved devices and methods for providing feedback information related to CQI, PMI, and RI in Rel-10 wireless networks that minimize overhead signaling while improving the granularity of the feedback information.

### SUMMARY

A mobile station is provided for use in a wireless network. The mobile station transmits feedback reports to a base station of the wireless network. The feedback reports comprise a first feedback report, a second feedback report and a third feedback report. The first feedback report includes a precoder type indication (PTI) value. The PTI value indicates at least one of a period of the second feedback report and a period of the third feedback report. In an advantageous embodiment, the PTI value indicates a ratio of the second feedback report period to the third feedback report period.

The second feedback report and the third feedback report include selected feedback information comprising at least one of wideband feedback information and subband feedback information. In an advantageous embodiment, the PTI value also indicates the selected feedback information.

A mobile station is provided for use in a wireless network. The mobile station operable to communicate with a base station that transmits using a precoder that is specified by a codebook. The mobile station performs rank-dependent codebook subset selection for subband  $W2$  feedback such that the mobile station transmits to the base station using a first subband  $W2$  codebook when the mobile station transmits a first precoder type indication (PTI) value and transmits to the base station using a second subband  $W2$  codebook when the mobile station transmits a second PTI value. The second subband  $W2$  codebook is a subset of the first subband  $W2$  codebook.

Before undertaking the DETAILED DESCRIPTION OF THE INVENTION below, it may be advantageous to set forth definitions of certain words and phrases used throughout this patent document: the terms "include" and "comprise," as well as derivatives thereof, mean inclusion without limitation; the term "or," is inclusive, meaning and/or; the phrases "associated with" and "associated therewith," as well as derivatives thereof, may mean to include, be included within, interconnect with, contain, be contained within, connect to or with, couple to or with, be communicable with, cooperate with, interleave, juxtapose, be proximate to, be bound to or with, have, have a property of, or the like. Definitions for certain words and phrases are provided throughout this patent document, those of ordinary skill in the art should understand that in many, if not most instances, such definitions apply to prior, as well as future uses of such defined words and phrases.

### BRIEF DESCRIPTION OF THE DRAWINGS

For a more complete understanding of the present disclosure and its advantages, reference is now made to the following description taken in conjunction with the accompanying drawings, in which like reference numerals represent like parts:

FIG. 1 illustrates an exemplary wireless network that performs feedback for the physical uplink control channel (PUCCH) according to the principles of the present disclosure;

FIG. 2 illustrates a base station in communication with a plurality of mobile stations according to an embodiment of the disclosure;

FIG. 3 illustrates a 4x4 multiple-input, multiple-output (MIMO) system according to an embodiment of the disclosure;

FIG. 4 illustrates feedback reports for a precoder type indicator (PTI) value of 0;

FIG. 5 illustrates feedback reports for a precoder type indicator (PTI) value of 01;

FIG. 6 illustrates modified feedback reports for a precoder type indicator (PTI) value of 1 in a first alternate embodiment;

FIG. 7 illustrates modified feedback reports for a precoder type indicator (PTI) value of 1 in a second alternate embodiment;

FIG. 8 illustrates modified feedback reports for a precoder type indicator (PTI) value of 1 in a third alternate embodiment;

FIG. 9 illustrates modified feedback reports for a precoder type indicator (PTI) value of 1 in which four report types are used;

FIG. 10 illustrates subband reporting instances for subband CQI/ $W2$  reporting according to a first alternative embodiment of the disclosure;

FIG. 11 illustrates subband reporting instances for subband CQI/ $W2$  reporting according to a second alternative embodiment of the disclosure; and

FIG. 12 illustrates subband reporting instances for subband CQI/ $W2$  reporting according to a third alternative embodiment of the disclosure.

### DETAILED DESCRIPTION

FIGS. 1 through 12, discussed below, and the various embodiments used to describe the principles of the present disclosure in this patent document are by way of illustration only and should not be construed in any way to limit the

scope of the disclosure. Those skilled in the art will understand that the principles of the present disclosure may be implemented in any suitably arranged wireless network.

FIG. 1 illustrates exemplary wireless network **100**, which performs feedback for the physical uplink control channel (PUCCH) according to the principles of the present disclosure. Wireless network **100** includes base station (BS) **101**, base station (BS) **102**, base station (BS) **103**, and other similar base stations (not shown). Base station **101** is in communication with Internet **130** or a similar IP-based network (not shown).

Depending on the network type, other well-known terms may be used instead of “base station,” such as “eNodeB”, “eNB”, or “access point”. For the sake of convenience, the term “base station” shall be used herein to refer to the network infrastructure components that provide wireless access to remote terminals.

Base station **102** provides wireless broadband access to Internet **130** to a first plurality of mobile stations within coverage area **120** of base station **102**. The first plurality of subscriber stations includes mobile station **111**, which may be located in a small business (SB), mobile station **112**, which may be located in an enterprise (E), mobile station **113**, which may be located in a WiFi hotspot (HS), mobile station **114**, which may be located in a first residence (R), mobile station **115**, which may be located in a second residence (R), and mobile station **116**, which may be a mobile device (M), such as a cell phone, a wireless laptop, a wireless PDA, or the like.

For the sake of convenience, the term “mobile station” is used herein to designate any remote wireless equipment that wirelessly accesses a base station, whether or not the mobile station is a truly mobile device (e.g., cell phone) or is normally considered a stationary device (e.g., desktop personal computer, vending machine, etc.). In other systems, other well-known terms may be used instead of “mobile station”, such as “subscriber station (SS)”, “remote terminal (RT)”, “wireless terminal (WT)”, “user equipment (LTE)”, and the like.

Base station **103** provides wireless broadband access to Internet **130** to a second plurality of mobile stations within coverage area **125** of base station **103**. The second plurality of mobile stations includes mobile station **115** and mobile station **116**. In an exemplary embodiment, base stations **101-103** may communicate with each other and with mobile stations **111-116** using OFDM or OFDMA techniques.

While only six mobile stations are depicted in FIG. 1, it is understood that wireless network **100** may provide wireless broadband access to additional mobile stations. It is noted that mobile station **115** and mobile station **116** are located on the edges of both coverage area **120** and coverage area **125**. Mobile station **115** and mobile station **116** each communicate with both base station **102** and base station **103** and may be said to be operating in handoff mode, as known to those of skill in the art.

Exemplary descriptions of closed-loop transmit beamforming schemes based on codebook design can be found in: 1) D. Love, J. Heath, and T. Strohmer, “Grassmannian Beamforming For Multiple-Input, Multiple-Output Wireless Systems,” IEEE Transactions on Information Theory, October 2003, and 2) V. Raghavan, A. M. Sayeed, and N. Boston, “Near-Optimal Codebook Constructions For Limited Feedback Beamforming In Correlated MIMO Channels With Few Antennas,” IEEE 2006 International Symposium on Information Theory. Both references are hereby incorporated by reference into this disclosure as if fully set forth herein.

Closed-loop codebook-based transmit beamforming may be used in a case where a base station forms a transmit antenna beam toward a single user or simultaneously toward multiple users at the same time and at a certain frequency. An exemplary description of such a system may be found in Quentin H. Spencer, Christian B. Peel, A. Lee Swindlehurst, Martin Harardt, “An Introduction To the Multi-User MIMO Downlink,” IEEE Communication Magazine, October 2004, which is hereby incorporated by reference into this disclosure as if fully set forth herein.

A codebook is a set of pre-determined antenna beams that are known to mobile stations. A codebook-based pre-coding MIMO may provide significant spectral efficiency gain in the downlink closed-loop MIMO. In the IEEE 802.16e and 3GPP LTE standards, a four transmit (4-TX) antenna limited feedback based closed-loop MIMO configuration is supported. In IEEE 802.16m and 3GPP LTE Advanced standards, in order to provide peak spectral efficiency, eight transmit (8-TX) antenna configurations are proposed as a prominent precoding closed-loop MIMO downlink system. Exemplary descriptions of such systems may be found in 3GPP Technical Specification No. 36.211, “Evolved Universal Terrestrial Radio Access (E-UTRA): Physical Channel and Modulation”, which is hereby incorporated by reference into this disclosure as if fully set forth herein.

To eliminate the need for the phase-calibration process in cases where channel sounding signals or common pilot signals (or midamble) are not used for data demodulation purpose, closed-loop transformed codebook-based transmit beamforming may be utilized. An exemplary description of such a system may be found in IEEE C802.16m-08/1345r2, “Transformation Method For Codebook Based Precoding,” November 2008, which is hereby incorporated by reference into this disclosure as if fully set forth herein. The transformed codebook method utilizes the channel correlation information to enhance the performance of the standard codebook, especially in the highly correlated channels, as well as to eliminate the need of phase calibration among multiple transmit antennas. Typically, the channel correlation information is based on second-order statistics and thus changes very slowly, which is similar to long-term channel effects, such as shadowing and path loss. As a result, the feedback overhead and computation complexity using correlation information are very small.

FIG. 2 illustrates diagram **200** of base station **220** in communication with a plurality of mobile stations **202**, **204**, **206**, and **208** according to an embodiment of the disclosure. Base station **220** and mobile stations **202**, **204**, **206**, and **208** employ multiple antennas for transmission and reception of radio wave signals. The radio wave signals may be Orthogonal Frequency Division Multiplexing (OFDM) signals.

In FIG. 2, base station **220** performs simultaneous beamforming through a plurality of transmitters to each mobile station. For instance, base station **220** transmits data to mobile station **202** through beamformed signal **210**, data to mobile station **204** through beamformed signal **212**, data to mobile station **406** through beamformed signal **214**, and data to mobile station **408** through beamformed signal **216**. In some embodiments, base station **220** may perform simultaneous beamforming to mobile stations **202**, **204**, **206**, and **208**. Each beamformed signal may be formed toward its intended mobile station at the same time and the same frequency. For the purpose of clarity, the communication from a base station to a mobile station may also be referred to as downlink communication and the communication from a mobile station to a base station may be referred to as uplink communication.

Base station **220** and mobile stations **202**, **204**, **206**, and **208** employ multiple antennas for transmitting and receiving wireless signals. It is understood that the wireless signals may be radio wave signals, and the wireless signals may use any transmission scheme known to one skilled in the art, including an Orthogonal Frequency Division Multiplexing (OFDM) transmission scheme.

Mobile stations **202**, **204**, **206**, and **208** may be any device that is capable of receiving wireless signals. Examples of mobile stations **202**, **204**, **206**, and **208** include, but are not limited to, a personal data assistant (PDA), laptop, mobile telephone, handheld device, or any other device that is capable of receiving the beamformed transmissions.

An OFDM transmission scheme is used to multiplex data in the frequency domain. Modulation symbols are carried on frequency sub-carriers. The quadrature amplitude modulation (QAM) modulated symbols are serial-to-parallel converted and input to the inverse fast Fourier transform (IFFT). At the output of the IFFT, N time-domain samples are obtained. Here N refers to the IFFT/fast Fourier transform (FFT) size used by the OFDM system. The signal after IFFT is parallel-to-serial converted and a cyclic prefix (CP) is added to the signal sequence. The CP is added to each OFDM symbol to avoid or mitigate the impact due to multipath fading. The resulting sequence of samples is referred to as an OFDM symbol with a CP. At the receiver side, assuming that perfect time and frequency synchronization are achieved, the receiver first removes the CP, and the signal is serial-to-parallel converted before being fed into the FFT. The output of the FFT is parallel-to-serial converted, and the resulting QAM modulation symbols are input to the QAM demodulator.

The total bandwidth in an OFDM system is divided into narrowband frequency units called subcarriers. The number of subcarriers is equal to the FFT/IFFT size N used in the system. In general, the number of subcarriers used for data is less than N because some subcarriers at the edge of the frequency spectrum are reserved as guard subcarriers. In general, no information is transmitted on guard subcarriers.

Because each OFDM symbol has finite duration in time domain, the sub-carriers overlap with each other in frequency domain. However, the orthogonality is maintained at the sampling frequency assuming the transmitter and receiver have perfect frequency synchronization. In the case of frequency offset due to imperfect frequency synchronization or high mobility, the orthogonality of the sub-carriers at sampling frequencies is destroyed, resulting in inter-carrier-interference (ICI).

The use of multiple transmit antennas and multiple receive antennas at both a base station and a single mobile station to improve the capacity and reliability of a wireless communication channel is known as a Single User Multiple-Input, Multiple-Output (SU-MIMO) system. A MIMO system provides a linear increase in capacity with K, where K is the minimum of the number of transmit antennas (M) and receive antennas (N) (i.e.,  $K=\min(M,N)$ ). A MIMO system can be implemented with the schemes of spatial multiplexing, transmit and receive beamforming, or transmit and receive diversity.

FIG. 3 illustrates a 4x4 multiple-input, multiple-output (MIMO) system **300** according to an embodiment of the disclosure. In this example, four different data streams **302** are transmitted separately using four transmit antennas **304**. The transmitted signals are received at four receive antennas **306** and interpreted as received signals **308**. Some form of spatial signal processing **310** is performed on the received signals **308** in order to recover four data streams **312**.

An example of spatial signal processing is Vertical-Bell Laboratories Layered Space-Time (V-BLAST), which uses the successive interference cancellation principle to recover the transmitted data streams. Other variants of MIMO schemes include schemes that perform some kind of space-time coding across the transmit antennas (e.g., Diagonal Bell Laboratories Layered Space-Time (D-BLAST)). In addition, MIMO can be implemented with a transmit and receive diversity scheme and a transmit and receive beamforming scheme to improve the link reliability or system capacity in wireless communication systems.

In channel status indicator (CSI) mode 1, the extension of PUCCH mode 2-1 (i.e., subband feedback mode) allows both the subband feedback and the wideband feedback to be multiplexed in the same feedback mode, depending on the value of the precoder type indication (PTI). More specifically, when PTI=0, both Report 2 and Report 3 are wideband reports and when PTI=1, Report 2 is a wideband report, while Report 3 is a subband report. When PTI=0, since Report 2 and Report 3 are both wideband, it is natural that the feedback periodicity of Report 2 and Report 3 are similar. However, when PTI=1, Report 3 is a subband report, which means that the feedback periodicity of the Report 3 should be smaller relative to the feedback periodicity of Report 2.

Let  $N_{P2}$  be the period of Report 2 and  $N_{P3}$  be the period of Report 3. By way of example, the unit of the period of both reports may be subframes. Then:

$$H=N_{P2}/N_{P3}+1,$$

where  $N_{P2}/N_{P3}$  is the ratio between the period of Report 2 and the period of Report 3. It is noted that the period ratio depends on the PTI value. Thus, in an advantageous embodiment of the disclosure, the value of H depends on the value of PTI. For example, when PTI=0,  $H=2$  or  $3$ , and when PTI=1,  $H=J*K+1$ , where J is the number of bandwidth parts and K is a constant that may be signalled from the base station (eNB) using higher layer signalling. In another example, when PTI=0, the value of H may be signalled by higher layers and when PTI=1, then  $H=J*K+1$ , where J is the number of bandwidth parts and K is a constant signalled by the base station using higher layer signalling.

Let  $N_{P1}$  be the period of Report 1, then:

$$M=N_{P1}/N_{P2}.$$

In an advantageous embodiment of the disclosure, the value of M also depends on the value of PTI. Furthermore, let  $M^0$  and  $H^0$  be the periodicity ratios when PTI=0, and let  $M^1$  and  $H^1$  be the periodicity ratios when PTI=1. Then, then the following condition among the four quantities holds:

$$H^0*M^0=H^1*M^1.$$

For a particular example, assume 10 MHz total system bandwidth. Accordingly,  $J=3$  bandwidth parts (BPs). If  $K=1$ , then  $H^1=4$ . If  $M^1=2$ , then  $H^1*M^1=4*2=8=H^0*M^0=2*4$ .

In some embodiments of the disclosure, the exact value of H and/or M may be signalled using higher layer signalling.

The feedback reports from mobile station (MS) to base station (BS) are seen more clearly in FIG. 4 and FIG. 5.

FIG. 4 illustrates feedback reports for a precoder type indicator (PTI) value of 0. In FIG. 4,  $H^0=2$  and  $M^0=4$ . Messages **401a** and **401b** are examples of Report 1, which contains Rank Indicator (RI) and a 1-bit PIT value=0. Messages **402a**, **402b**, **402c**, and **402d** are examples of Report 2, which contains the precoder matrix value, W1 (also referred to as "a first PMI"). Messages **403a**, **403b**, **403c**, and **403d** are examples of Report 3, which contains the

wideband precoder matrix value (WB W2) and a wideband channel quality indicator (WB CQI) value.

Thus, for each instance of Report 1, there are 4 instances of Report 2 and 4 instances of Report 3 (i.e.,  $M=4$ , since period of Report 1 is 4 times period of Report 2). Also, for each instance of Report 2, there is one instance of Report 3 (i.e.,  $H=2$ , since period of Report 2 equals period of Report 3).

FIG. 5 illustrates feedback reports for a precoder type indicator (PTI) value of 1. In FIG. 5,  $H^1=4$  and  $M^1=2$ . Messages 501a and 501b are examples of Report 1, which contains Rank Indicator (RI) and a 1-bit PTI value=1. Messages 502a and 502b are examples of Report 2, which contains the wideband precoder matrix value, WB W2, and the WB CQI value. Messages 503a, 503b and 503c are examples of Report 3, which contains the subband precoder matrix value, SB W2, and the subband channel quality indicator (SB CQI) value.

Thus, for each instance of Report 1, there are 2 instances of Report 2 and 6 instances of Report 3 (i.e.,  $M=2$ , since the period of Report 1 is 2 times the period of Report 2). Also, for each instance of Report 2, there are three instances of Report 3 (i.e.,  $H=4$ , since period of Report 2 is 3 times the period of Report 3).

In the example, no feedback information related to W1 is reported following the rank report when PTI=1. This means that in order to perform subband-based feedback, the mobile station may feedback PTI=0 first. However, during the next RI feedback, the mobile station ensures the same W1 is reported in the previous subframe. Otherwise, the mobile station should not perform subband feedback. This may restrict scheduling flexibility in the base station and may increase the complexity of the mobile station.

In an advantageous embodiment of the disclosure, wideband feedback information is transmitted in the feedback report (Report 2) following Report 1, where PTI=1.

In a first alternative embodiment (ALT 1), the W1 information is reported together with wideband W2 and wideband CQI in Report 2 when PTI=1. Thus, Report 1 includes RI and 1-bit precoder type indication (PTI). In Report 2, if PTI=0, then W1 is reported. If PTI=1, then W1, wideband CQI, and wideband W2 are reported. In Report 3, if PTI=0, then wideband CQI and wideband W2 are reported. If PTI=1, then subband CQI and subband W2 are reported. The first alternative embodiment is depicted in FIG. 6.

FIG. 6 illustrates modified feedback reports for a precoder type indicator (PTI) value of 1 in the first alternate embodiment. In FIG. 6,  $H^1=4$  and  $M^1=2$ . FIG. 6 is similar to FIG. 5 in many respects. Messages 501a and 501b are examples of Report 1, which contains Rank Indicator (RI) and a 1-bit PTI value=1. Similarly, messages 503a, 503b and 503c are examples of Report 3, which contains the subband precoder matrix value, SB W2, and the subband channel quality indicator (SB CQI) value. However, messages 601a and 601b are new. Messages 601a and 601b are examples of Report 2. Since PTI=1, messages 601a and 601b include wideband W1, wideband W2, and wideband CQI.

Furthermore, in order to limit the maximum payload size of Report 2 to 11 bits, codebook subset selection (codebook sub-sampling) is performed on the codebook of W1 and/or the codebook of W2. Accordingly, conditioned on the value of PTI, the codebook of W1 can be either sub-sampled or not sub-sampled. If PTI=0, then C1 (the codebook of W1) is not sub-sampled (codebook subset selection is not applied to C1). If PTI=1, then C1 (the codebook of W1) is sub-sampled (codebook subset selection is applied to C1).

In a second alternative embodiment (ALT 2), the W1 information is reported together with wideband CQI in Report 2 when PTI=1. Thus, Report 1 includes RI and 1-bit precoder type indication (PTI). In Report 2, if PTI=0, then W1 is reported. If PTI=1, then W1 and wideband CQI are reported. In Report 3, if PTI=0, then wideband CQI and wideband W2 are reported. If PTI=1, then subband CQI and subband W2 are reported. The second alternative embodiment is depicted in FIG. 7.

FIG. 7 illustrates modified feedback reports for a precoder type indicator (PTI) value of 1 in the second alternate embodiment. In FIG. 7,  $H^1=4$  and  $M^1=2$ . FIG. 7 is similar to FIGS. 5 and 6 in many respects. Messages 501a and 501b are examples of Report 1, which contains Rank Indicator (RI) and a 1-bit PTI value=1. Similarly, messages 503a, 503b and 503c are examples of Report 3, which contains the subband precoder matrix value, SB W2, and the subband channel quality indicator (SB CQI) value. However, messages 701a and 701b are new. Messages 701a and 701b are examples of Report 2. Since PTI=1, messages 701a and 701b include wideband W1 and wideband CQI.

In a third alternative embodiment (ALT 3), the W1 information is reported in Report 2 when PTI=1. Thus, Report 1 includes RI and 1-bit precoder type indication (PTI). In Report 2, if PTI=0, then W1 is reported. If PTI=1, then W1 is reported. In Report 3, if PTI=0, then wideband CQI and wideband W2 are reported. If PTI=1, then subband CQI and subband W2 are reported. The third alternative embodiment is depicted in FIG. 8.

FIG. 8 illustrates modified feedback reports for a precoder type indicator (PTI) value of 1 in the third alternate embodiment. In FIG. 8,  $H^1=4$  and  $M^1=2$ . FIG. 8 is similar to FIGS. 5-7 in many respects. Messages 501a and 501b are examples of Report 1, which contains Rank Indicator (RI) and a 1-bit PTI value=1. Similarly, messages 503a, 503b and 503c are examples of Report 3, which contains the subband precoder matrix value, SB W2, and the subband channel quality indicator (SB CQI) value. However, messages 801a and 801b are new. Messages 801a and 801b are examples of Report 2. Since PTI=1, messages 801a and 801b include wideband W1.

In still another embodiment of the disclosure, a new report is added when PTI=1. Thus, there will be four reports in this CSI mode. However, the precoder W is determined on a 3-subframe report conditioned on the last rank indicator (RI) value transmitted. Thus, Report 1 includes RI and 1-bit precoder type indication (PTI). In Report 2, if PTI=0, then W1 is reported and if PTI=1, then W1 is reported (similar to FIG. 8). In Report 3, if PTI=0, then wideband CQI and wideband W2 are reported and if PTI=1, then wideband CQI and wideband W2 are reported. In Report 4, if PTI=0, there is no report. If PTI=1, then subband CQI and subband W2 are reported.

In this way, PTI serves to turn on/off subband CQI report and Report 4 (subband CQI/W2) is only reported when PTI=1. This alternative embodiment is depicted in FIG. 9.

FIG. 9 illustrates modified feedback reports for a precoder type indicator (PTI) value of 1 in which four report types are used. FIG. 9 is similar to FIGS. 5-8 in many respects. Messages 501a and 501b are examples of Report 1, which contains Rank Indicator (RI) and a 1-bit PTI value=1. Messages 801a and 801b are examples of Report 2. Since PTI=1, messages 801a and 801b include wideband W1. Similarly, messages 503a and 503b are examples of Report 3, which contains SB W2 and SB CQI.

However, messages 901a and 901b are new. Messages 901a and 901b are example of Report 4. Since PTI=1,

11

messages 901a and 901b include subband CQI and subband W2. If PTI had been 0, there would be no Report 4.

In an advantageous embodiment of the present disclosure, when PTI=1, the feedback periods of Report 2 and Report 3 are the same and the following conditions hold:

$$N_{P2}=N_{P3};$$

$$H=N_{P2}/N_{P4}=J*K+2; \text{ and}$$

$$M=N_{P1}/N_{P2}.$$

According to the codebook agreement in Document No. R1-105011 and the Chairman's notes, the payloads for W2 are listed as follows: Rank 1=4 bits, Rank 2=4 bits, Rank 3=4 bits, and Rank 4=3 bits. The bit-widths of Report 3 when PTI=1 is shown in TABLE 1 below.

TABLE 1

RANK	W2	CQI	L-BIT SUBBAND INDICATION	TOTAL PAY-LOAD
RANK 1	4 BITS	4 BITS	1-2 BITS DEPENDING ON BW	10
RANK 2	4 BITS	4 + 3 BITS	1-2 BITS DEPENDING ON BW	13
RANK 3	4 BITS	4 + 3 BITS	1-2 BITS DEPENDING ON BW	13
RANK 4	3 BITS	4 + 3 BITS	1-2 BITS DEPENDING ON BW	12
RANK	0 BITS	4 + 3 BITS	1-2 BITS DEPENDING ON BW	9

However, it is already agreed that the payload of PUCCH format 2 should be restricted to 11 bits. Therefore, as shown in TABLE 1, for rank 2 (13 bits), rank 3 (13 bits) and rank 4 (12 bits), the bit-widths of the current payloads of PUCCH format 2 cannot accommodate both subband W2, subband CQI and L-bit bandwidth part (BP) indication in TABLE 1.

In one embodiment of disclosure, the L-bit subband indicator in the Rel-8 subband CQI feedback is retained. However, the following alternatives are used to constrain the payload of subband feedback to within 11 bits.

Alternative 1:

Codebook subset selection (codebook sub-sampling) is performed for subband W2 in CSI mode 1. That is, the codebook of W2 (C2) for subband feedback in PUCCH feedback is a subset of the codebook of W2 for wideband feedback in PUCCH feedback. For example, C2 of W2, when PTI=1, is a subset of C2 of W2 when PTI=0 in PUCCH feedback. Also, C2 of W2, when PTI=1, in PUCCH feedback is a subset of C2 of W2 in PUSCH feedback. For the example where C2 is sub-sampled and the payload for the sub-sampled C2 is 2 bits, TABLE 2 below shows the payloads for subband CQI feedback in CSI mode 1.

TABLE 2

RANK	W2	COI	L-BIT SUBBAND INDICATION	TOTAL PAY-LOAD
RANK 1	2 BITS	4 BITS	1-2 BITS DEPENDING ON BW	8
RANK 2	2 BITS	4 + 3 BITS	1-2 BITS DEPENDING ON BW	11
RANK 3	2 BITS	4 + 3 BITS	1-2 BITS DEPENDING ON BW	11
RANK 4	2 BITS	4 + 3 BITS	1-2 BITS DEPENDING ON BW	11
RANK	0 BITS	4 + 3 BITS	1-2 BITS DEPENDING ON BW	9

Alternative 1:

Rank dependent codebook subset selection (codebook sub-sampling) is performed for subband W2 feedback when PTI=1. For example, Rank 2/3/4 codebook of W2 when PTI=1 is a subset of W2 when PTI=0 in PUCCH feedback.

12

Also, Rank 2/3/4 codebook of W2 when PTI=1 in PUCCH feedback is a subset of W2 in PUSCH feedback. For the example where the C2 is sub-sampled and the payload for the sub-sampled C2 is 2 bits for rank 2/3/4, TABLE 3 below shows the payloads for subband CQI feedback in CSI mode 1.

TABLE 3

RANK	W2	CQI	L-BIT SUBBAND INDICATION	TOTAL PAY-LOAD
RANK 1	4 BITS	4 BITS	1-2 BITS DEPENDING ON BW	10
RANK 2	2 BITS	4 + 3 BITS	1-2 BITS DEPENDING ON BW	11
RANK 3	2 BITS	4 + 3 BITS	1-2 BITS DEPENDING ON BW	11
RANK 4	2 BITS	4 + 3 BITS	1-2 BITS DEPENDING ON BW	11
RANK	0 BITS	4 + 3 BITS	1-2 BITS DEPENDING ON BW	9

In another embodiment of the disclosure, the L-bit subband indication is removed for all ranks. In addition, between every two consecutive Report 2 instances, the remaining H-1 or H-2 (depending on whether wideband W2 and wideband CQI are separately reported from W1) reporting instances are used in sequence for subband CQI/W2 reports to cycle through the bandwidth part together with the subband within the bandwidth part. For example, when H=J\*K+1 and wideband W2/CQI are sent together with W1, there are J\*K(H-1) reporting instances between the two consecutive Report 2 feedback instances.

The present disclosure proposes multiple orders to cycle through bandwidth part and subband within the corresponding bandwidth part in the assigned subband reporting instances.

Alternative 1:

Between two consecutive Report 2 feedbacks, the remaining J\*K(H-1) or J\*K(H-2) reporting instances are used in sequence for subband CQI/W2 reports on each subband. FIG. 10 illustrates subband reporting instances for subband CQI/W2 reporting according to the first alternative embodiment of the disclosure. In FIG. 10, three bandwidth parts, BP1, BP2, and BP3 are shown. The first three reporting instances sequence through each of the three subbands of bandwidth part BP1. The fourth reporting instance then begins sequencing through bandwidth part BP2.

Alternative 2:

Between two consecutive Report 2 feedbacks, the remaining J\*K(H-1) or J\*K(H-2) reporting instances are used in sequence for subband CQI/W2 reports on K cycles of bandwidth parts. Furthermore, within the i<sup>th</sup> cycle of a bandwidth part, the mobile station reports the i<sup>th</sup> subband bandwidth within each bandwidth part. FIG. 11 illustrates subband reporting instances for subband CQI/W2 reporting according to the second alternative embodiment of the disclosure. In FIG. 11, three bandwidth parts, BP1, BP2, and BP3 are shown. The first three reporting instances sequence through the first subband of each of bandwidth parts BP1, BP2 and BP3. The fourth reporting instance then begins sequencing through the second subband of each of bandwidth parts BP1, BP2 and BP3.

Alternative 3:

Between two consecutive Report 2 feedbacks, the remaining J\*K(H-1) or J\*K(H-2) reporting instances are used in sequence for subband CQI/W2 reports on K cycles of bandwidth parts. Furthermore, assuming there are at most T=2<sup>L</sup> subbands within each bandwidth part, then within the

$i^{th}$  cycle of a bandwidth part, the mobile station reports the  $i^{th}$  subband bandwidth with each bandwidth part.

By way of example, the mapping between  $i$  and  $j$  for the case  $K=4$  and  $T=4$  shown below in TABLE 4 may be used.

TABLE 4

$i$	$J$
1	1
2	T
3	2
4	T-1

In general, for  $k=1, 2, 3, \dots$ , if  $i=2*k-1$ , then  $j=k$ , and if  $i=2*k$ , then  $j=T-k+1$ .

FIG. 11 illustrates subband reporting instances for subband CQI/W2 reporting according to the third alternative embodiment of the disclosure.

In one embodiment of the present disclosure, the subband size within a bandwidth part depends on the rank indicator. That is, there may be larger subband sizes for higher ranks. Furthermore, the subband CQI/W2 feedback pattern depends on different ranks, as well.

In one embodiment of the present disclosure, the L-bit subband indication for rank 2, 3, 4 feedback may be removed while keeping the L-bit subband indication for rank 1 and ranks 5-8. Accordingly, TABLE 5 below shows the payload sized for subband CQI feedback in CSI mode 1 that may be achieved. In one embodiment, RI and PTI may be jointly encoded in CSI mode 1.

TABLE 5

RANK	W2	CQI	L-BIT SUBBAND INDICATION	TOTAL PAYLOAD
RANK 1	4 BITS	4 BITS	1-2 BITS DEPENDING ON BW	10
RANK 2	4 BITS	4 + 3 BITS	0	11
RANK 3	4 BITS	4 + 3 BITS	0	11
RANK 4	3 BITS	4 + 3 BITS	0	10
RANK 5-8	0 BITS	4 + 3 BITS	1-2 BITS DEPENDING ON BW	9

Although the present disclosure has been described with an exemplary embodiment, various changes and modifications may be suggested to one skilled in the art. It is intended that the present disclosure encompass such changes and modifications as fall within the scope of the appended claims.

What is claimed is:

1. For use in a wireless network, a mobile station comprising:

- at least one antenna; and
- a processing circuit operable to transmit feedback reports to a base station of the wireless network, the feedback reports comprising a first feedback report, a second feedback report and a third feedback report, wherein the first feedback report includes a precoder type indication (PTI) value [and], wherein at least one of a [period] periodicity of the second feedback report and a [period] periodicity of the third feedback report is indicated by the PTI value, wherein, when  $PTI=0$ , a ratio  $H$  of the periodicity of the second feedback report and the periodicity of the third feedback report is signaled by a higher layer, and

wherein, when  $PTI=1$ , the ratio  $H=J*K+1$ , where  $J$  is a number of bandwidth parts and  $K$  is a constant signaled by a base station using higher layer signaling.

2. The mobile station as set forth in claim 1, wherein the PTI value indicates a ratio of the second feedback report period to the third feedback report period.]

3. The mobile station as set forth in claim 2, wherein when the PTI value is 0, the ratio is signaled by a higher-layer message and when the PTI value is 1, the ratio is given by  $J*K+1$ , where  $J$  is the number of bandwidth parts and  $K$  is a constant signaled by a higher layer message.]

4. The mobile station as set forth in claim 1, wherein the second feedback report and the third feedback report include selected feedback information, the selected feedback information comprising at least one of wideband feedback information and subband feedback information.

5. The mobile station as set forth in claim 4, wherein the PTI value indicates the selected feedback information.

6. A method for use in a mobile station operable to transmit feedback reports to a base station of a wireless network, the method including:

- transmitting to the base station a first feedback report including a precoder type indication (PTI) value;
- transmitting to the base station a second feedback report; and

transmitting to the base station a third feedback report, wherein the PTI value indicates at least one of a [period] periodicity of the second feedback report and a [period] periodicity of the third feedback report,

wherein, when  $PTI=0$ , a ratio  $H$  of the periodicity of the second feedback report and the periodicity of the third feedback report is signaled by a higher layer, and wherein, when  $PTI=1$ , the ratio  $H=J*K+1$ , where  $J$  is a number of bandwidth parts and  $K$  is a constant signaled by a base station using higher layer signaling.

7. The method as set forth in claim 6, wherein the PTI value indicates a ratio of the second feedback report period to the third feedback report period.]

8. The method as set forth in claim 7, wherein when the PTI value is 0, the ratio is signaled by a higher-layer message and when the PTI value is 1, the ratio is given by  $J*K+1$ , where  $J$  is the number of bandwidth parts and  $K$  is a constant signaled by a higher layer message.]

9. The method as set forth in claim 6, wherein the second feedback report and the third feedback report include selected feedback information, the selected feedback information comprising at least one of wideband feedback information and subband feedback information.

10. The method as set forth in claim 9, wherein the PTI value indicates the selected feedback information.

11. For use in a wireless network, a base station comprising:

- at least one antenna; and
- a processing circuit operable to receive feedback reports transmitted by a mobile station, the feedback reports comprising a first feedback report, a second feedback report and a third feedback report, wherein the base station is configured to identify in the first feedback report a precoder type indication (PTI) value, [and] wherein the base station is configured to use the PTI value to determine at least one of a [period] periodicity of the second feedback report and a [period] periodicity of the third feedback report, wherein, when  $PTI=0$ , a ratio  $H$  of the periodicity of the second feedback report and the periodicity of the third feedback report is signaled by a higher layer, and

15

wherein, when  $PTI=1$ , the ratio  $H=J*K+1$ , where  $J$  is a number of bandwidth parts and  $K$  is a constant signaled by a base station using higher layer signaling.

[12. The base station as set forth in claim 11, wherein base station is configured to use the PTI value to determine a ratio of the second feedback report period to the third feedback report period.]

13. The base station as set forth in claim [12] 11, wherein the base station is configured to receive from the mobile station a control signal indicating the ratio.

14. The base station as set forth in claim 11, wherein the second feedback report and the third feedback report include selected feedback information, the selected feedback information comprising at least one of wideband feedback information and subband feedback information.

15. The base station as set forth in claim 14, wherein the base station is configured to use the PTI value to determine the selected feedback information.

16. A method for use in a base station of a wireless network operable to receive feedback reports transmitted by a mobile station, the method comprising:

receiving a first feedback report;  
identifying in the first feedback report a precoder type indication (PTI) value;

determining from the PTI value at least one of a [period] periodicity of a second feedback report and a [period] periodicity of a third feedback report;

receiving the second feedback report; and

receiving the third feedback report,

wherein, when  $PTI=0$ , a ratio  $H$  of the periodicity of the second feedback report and the periodicity of the third feedback report is signaled by a higher layer, and

wherein, when  $PTI=1$ , the ratio  $H=J*K+1$ , where  $J$  is a number of bandwidth parts and  $K$  is a constant signaled by a base station using higher layer signaling.

[17. The method as set forth in claim 16, further comprising determining a ratio of the second feedback report period to the third feedback report period.]

18. The method as set forth in claim [17] 16, wherein the base station receives from the mobile station a control signal indicating the ratio.

19. The method as set forth in claim 16, wherein the second feedback report and the third feedback report include selected feedback information, the selected feedback information comprising at least one of wideband feedback information and subband feedback information.

20. The method as set forth in claim 19, further comprising determining from the PTI value the selected feedback information.

21. A method for transmitting channel status information (CSI) in a communication system, comprising:

reporting a precoder type indicator (PTI); and

reporting a first wideband precoder matrix index (PMI), a second wideband PMI and a subband PMI in an interval following the reporting of the PTI and before a subsequent reporting of the PTI, and

wherein reporting instances for the first wideband PMI the second wideband PMI and the subband PMI are determined based on the PTI,

wherein, when  $PTI=0$ , the reporting instance of at least one of the first wideband PMI the second wideband PMI and the subband PMI is determined based on a value  $H$  signaled by a higher layer, and

wherein, when  $PTI=1$ , the reporting instance of at least one of the first wideband PMI, the second wideband PMI and the subband PMI is determined based on the value  $H=J*K+1$ , where  $J$  is a number of bandwidth

16

parts and  $K$  is a constant signaled by a base station using higher layer signaling.

22. The method of claim 21, wherein the PTI and a wideband CQI are reported on a physical uplink control channel (PUCCH).

23. The method of claim 21, wherein, when the PTI is 1, the first and second wideband PMI are reported in a next reporting instance.

24. A method for receiving channel status information (CSI) in a communication system, comprising:

receiving a report including a precoder type indicator (PTI); and

receiving a report including a first wideband precoder matrix index (PMI) and a second wideband PMI and a report including a subband PMI in an interval following the reporting of the PTI and before a subsequent reporting of the PTI,

wherein reporting instances for the first wideband PMI, the second wideband PMI and the subband PMI are determined based on the PTI,

wherein, when  $PTI=0$ , the reporting instance of at least one of the first wideband PMI, the second wideband PMI and the subband PMI is determined based on a value  $H$  signaled by a higher layer, and

wherein, when  $PTI=1$ , the reporting instance of at least one of the first wideband PMI, the second wideband PMI and the subband PMI is determined based on the value  $H=J*K+1$ , where  $J$  is a number of bandwidth parts and  $K$  is a constant signaled by a base station using higher layer signaling.

25. The method of claim 24, wherein the PTI and a wideband CQI are received on a physical uplink control channel (PUCCH).

26. The method of claim 24, wherein when the PTI is 1, the report including the first wideband PMI and the second wideband PMI is received in a next reporting instance.

27. A terminal for transmitting channel status information (CSI) in a communication system, comprising:

a transceiver for transmitting signals to and from a base station; and

a controller configured to control to report a precoder type indicator (PTI), a first wideband precoder matrix index (PMI), a second wideband PMI, and a subband PMI in an interval following the reporting of the PTI and before a subsequent reporting of the PTI,

wherein reporting instances for the first wideband PMI, the second wideband PMI and the subband PMI are determined based on the PTI,

wherein, when  $PTI=0$ , the reporting instance of at least one of the first wideband PMI, the second wideband PMI and the subband PMI is determined based on a value  $H$  signaled by a higher layer, and

wherein, when  $PTI=1$ , the reporting instance of at least one of the first wideband PMI, the second wideband PMI and the subband PMI is determined based on the value  $H=J*K+1$ , where  $J$  is a number of bandwidth parts and  $K$  is a constant signaled by a base station using higher layer signaling.

28. The terminal of claim 27, wherein the PTI and a wideband CQI are reported on a physical uplink control channel (PUCCH).

29. The terminal of claim 27, wherein when the PTI is 1, the first and second wideband PMI are reported in a next reporting instance.

30. A base station for receiving channel status information (CSI) in a communication system, comprising:

17

- a transceiver for transmitting signals to and from a terminal; and  
 a controller configured to control to receive a report including a precoder type indicator (PTI), and receive a report including a first wideband precoder matrix index (PMI) and a second wideband PMI and a report including a subband PMI in an interval following the reporting of the PTI and before a subsequent reporting of the PTI,  
 wherein reporting instances for the first wideband PMI, the second wideband PMI and the subband PMI are determined based on the PTI,  
 wherein, when  $PTI=0$ , the reporting instance of at least one of the first wideband PMI, the second wideband PMI and the subband PMI is determined based on a value  $H$  signaled by a higher layer, and  
 wherein, when  $PTI=1$ , the reporting instance of at least one of the first wideband PMI, the second wideband PMI and the subband PMI is determined based on the value  $H=J*K+1$ , where  $J$  is a number of bandwidth parts and  $K$  is a constant signaled by a base station using higher layer signaling.
31. The base station of claim 30, wherein the PTI and a wideband CQI are received on a physical uplink control channel (PUCCH).
32. The base station of claim 30, wherein when the PTI is 1, the report including the first wideband PMI and the second wideband PMI is received in a next reporting instance.
33. The mobile station as set forth in claim 1, wherein the mobile station is further configured to:

18

- transmit one of the second feedback report and the third feedback report with a period indicated by the PTI value.
34. The method as set forth in claim 6, further comprising: transmitting one of the second feedback report and the third feedback report with a period indicated by the PTI value.
35. The base station as set forth in claim 11, wherein the base station is further configured to:  
 receive one of the second feedback report and the third feedback report with a period indicated determined from the PTI value.
36. The method as set forth in claim 16, further comprising:  
 receiving one of the second feedback report and the third feedback report with a period indicated determined from the PTI value.
37. The method of claim 21, further comprising:  
 reporting the wideband PMI in the reporting instance determined based on the PTI.
38. The method of claim 24, further comprising:  
 receiving the wideband PMI in the reporting instance determined based on the PTI.
39. The terminal of claim 27, wherein the terminal is further configured to:  
 report the wideband PMI in the reporting instance determined based on the PTI.
40. The base station of claim 30, wherein the base station is further configured to:  
 receive the wideband PMI in the reporting instance determined based on the PTI.

\* \* \* \* \*