



US00RE44001E

(19) **United States**  
(12) **Reissued Patent**  
**Pedicini et al.**

(10) **Patent Number:** **US RE44,001 E**  
(45) **Date of Reissued Patent:** **Feb. 19, 2013**

- (54) **FASTENER DRIVING APPARATUS**
- (75) Inventors: **Christopher Pedicini**, Nashville, TN  
(US); **John Witzigreuter**, Canton, GA  
(US)
- (73) Assignee: **Tricord Solutions, Inc.**, Nashville, TN  
(US)
- (21) Appl. No.: **13/021,424**
- (22) Filed: **Feb. 4, 2011**

3,255,674	A	6/1966	Nelson et al.	
3,397,828	A *	8/1968	Volkman	227/130
3,434,393	A *	3/1969	Cairatti	91/417 A
3,568,780	A *	3/1971	Matsuo	173/201
3,580,458	A *	5/1971	Monacelli	227/124
3,602,103	A *	8/1971	Powers	91/443
3,821,992	A *	7/1974	Matsuo	173/200
3,878,902	A *	4/1975	Matsuo	173/14
4,033,419	A *	7/1977	Pennington	173/34
4,344,555	A *	8/1982	Wolfberg	227/130
6,499,643	B1	12/2002	Hewitt	
6,755,336	B2	6/2004	Harper et al.	
7,419,079	B2 *	9/2008	Chen et al.	227/130
2007/0175945	A1 *	8/2007	Chen et al.	227/130
2007/0181629	A1 *	8/2007	Chen et al.	227/130
2008/0190988	A1	8/2008	Pedicini et al.	

**Related U.S. Patent Documents**

Reissue of:

- (64) Patent No.: **7,793,811**  
Issued: **Sep. 14, 2010**  
Appl. No.: **12/616,227**  
Filed: **Nov. 11, 2009**

U.S. Applications:

- (60) Provisional application No. 61/208,556, filed on Feb. 25, 2009.

- (51) **Int. Cl.**  
**B25C 1/04** (2006.01)  
**B25C 1/06** (2006.01)
- (52) **U.S. Cl.** ..... 227/2; 227/131; 227/130; 60/370
- (58) **Field of Classification Search** ..... 60/370,  
60/387; 91/417 A, 417 R  
See application file for complete search history.

(56) **References Cited**

**U.S. PATENT DOCUMENTS**

1,071,387	A *	8/1913	Behr	173/201
1,319,975	A *	10/1919	Smith	173/78
1,382,821	A *	6/1921	Coates	60/370
1,829,609	A *	10/1931	Robinson	173/201

\* cited by examiner

*Primary Examiner* — Lindsay Low

(74) *Attorney, Agent, or Firm* — Aidenbaum Schloff and Bloom PLLC; Jay Schloff

(57) **ABSTRACT**

A fastener driving apparatus includes a power source, a control circuit, a motor, a first cylinder, a first piston, a linear motion converter, a second cylinder, a second piston, an anvil, a valve arrangement and at least one sensor. During a compression stroke, the first piston is configured to compress gas in a first cylinder to a predetermined pressure. At the predetermined pressure, the valve arrangement assumes an open position for communicating the compressed gas to the second cylinder, thereby causing the second piston to move linearly and enabling the anvil to drive the fastener into the workpiece. During a return stroke, at a predetermined position of the first piston in the first cylinder, the valve arrangement assumes the open position for communicating a vacuum created in the first cylinder to the second cylinder and thereby causing the second piston and the anvil to retract to their initial positions.

**17 Claims, 10 Drawing Sheets**

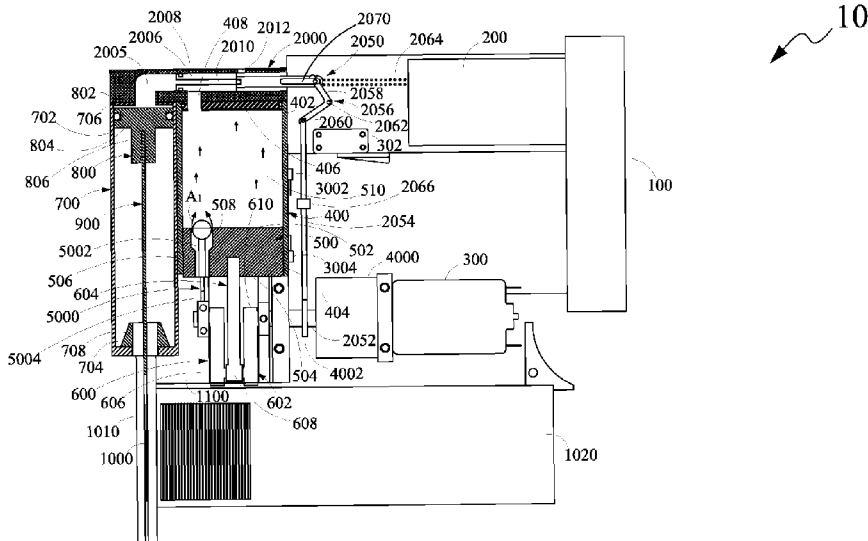

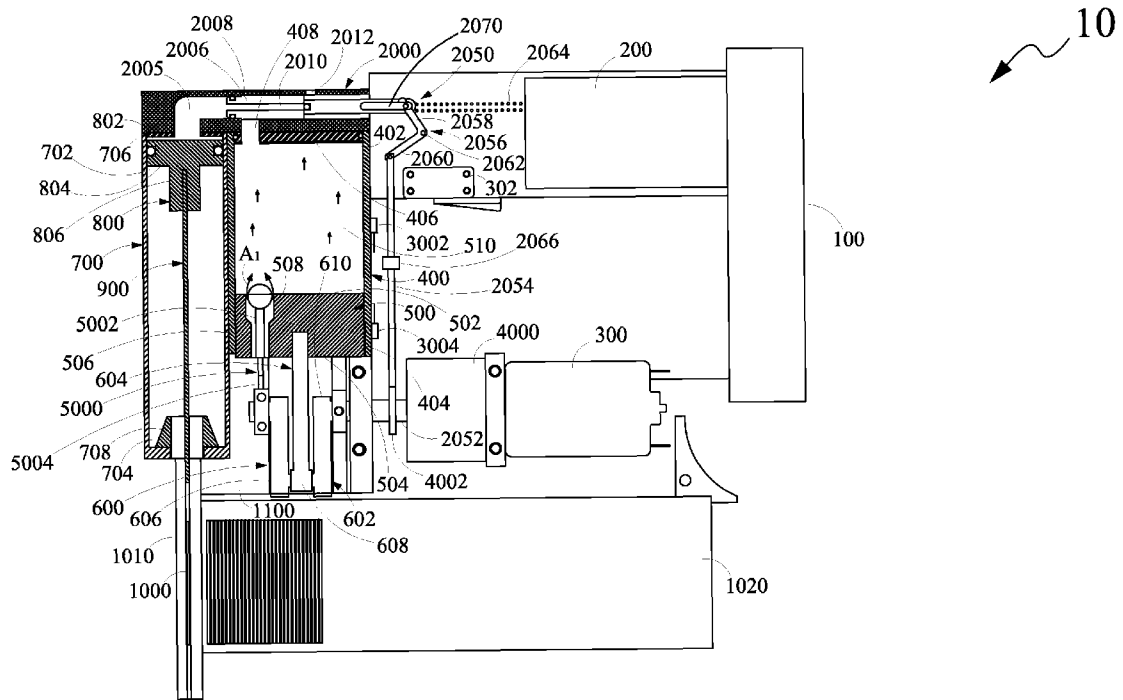

FIG. 1

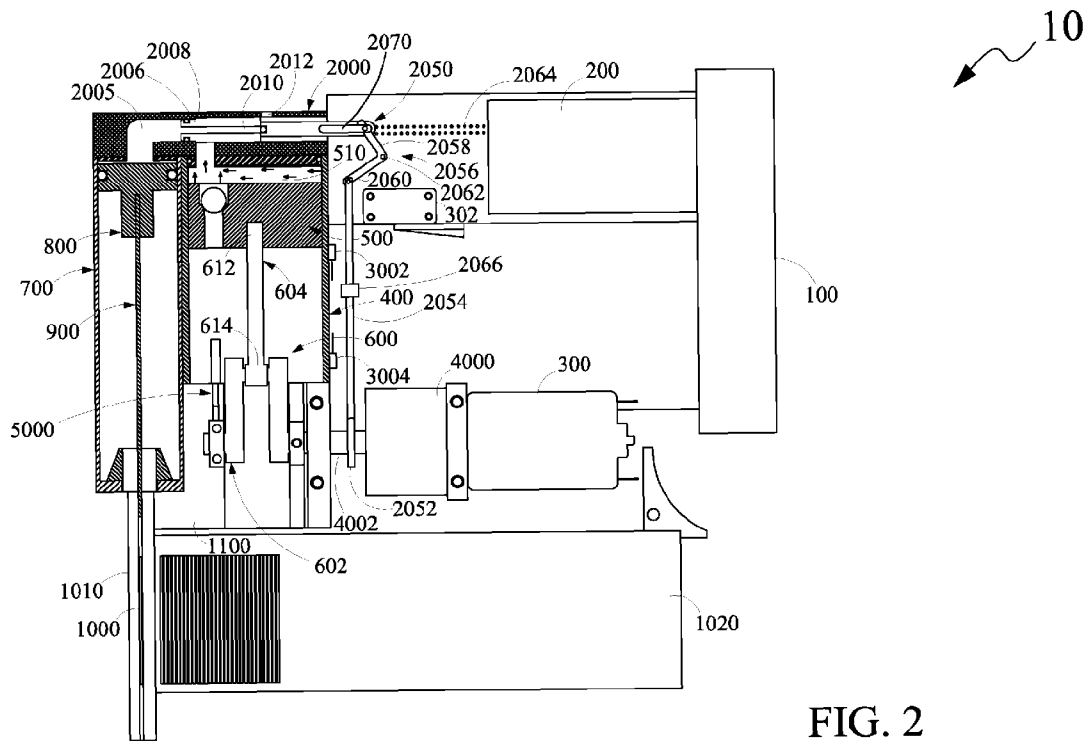

FIG. 2



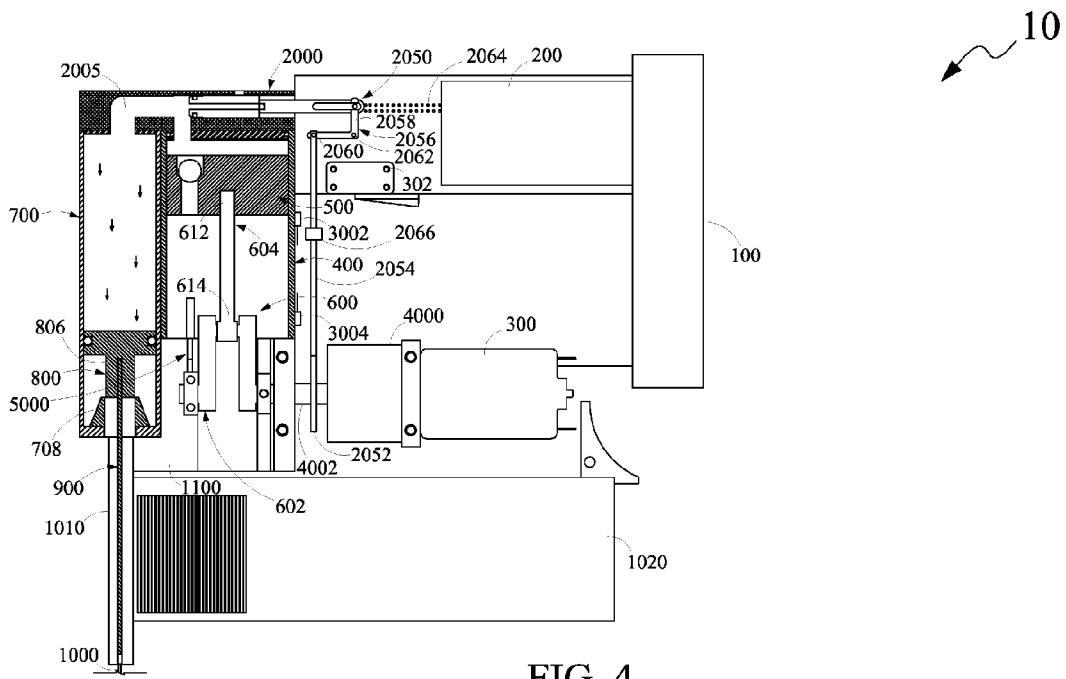

FIG. 4

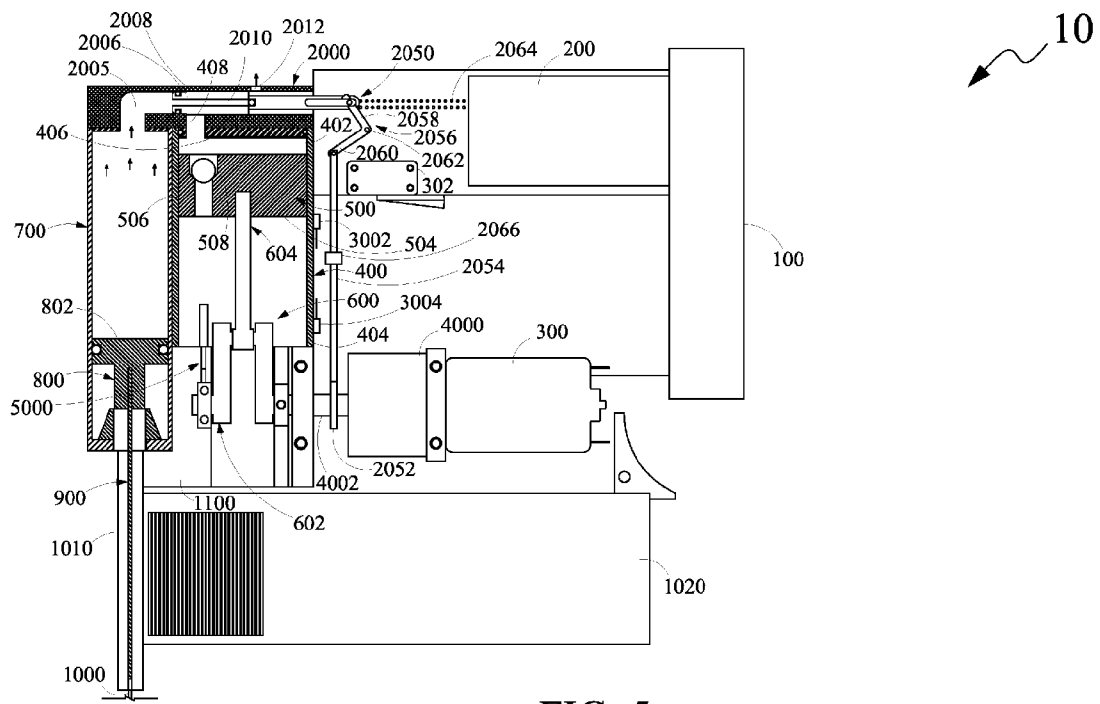

FIG. 5

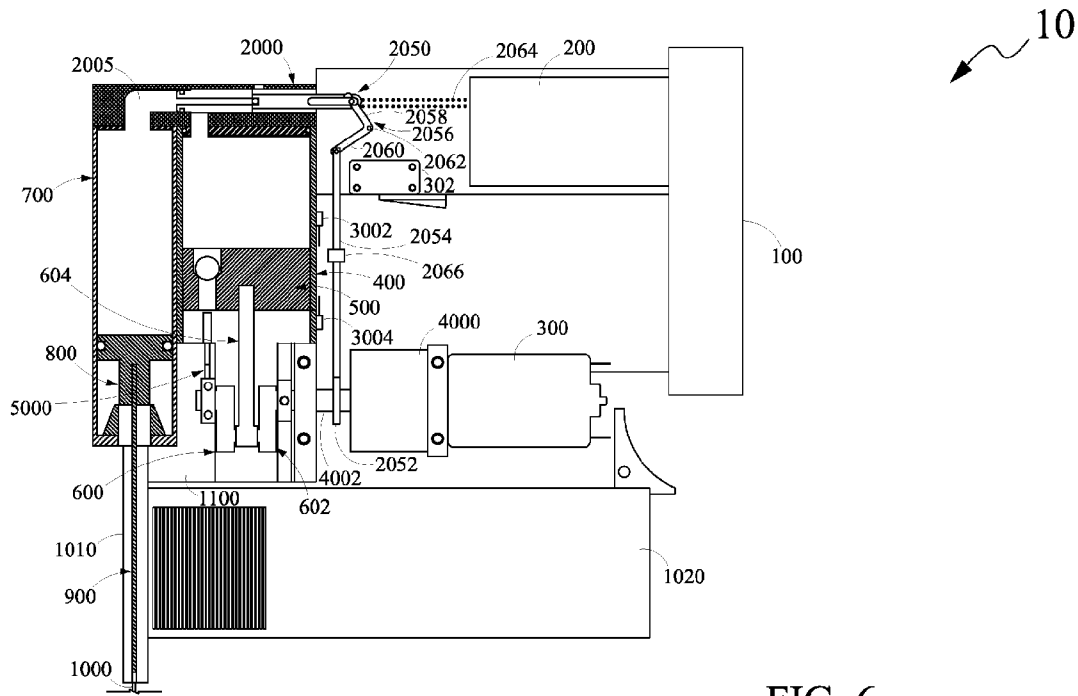

FIG. 6

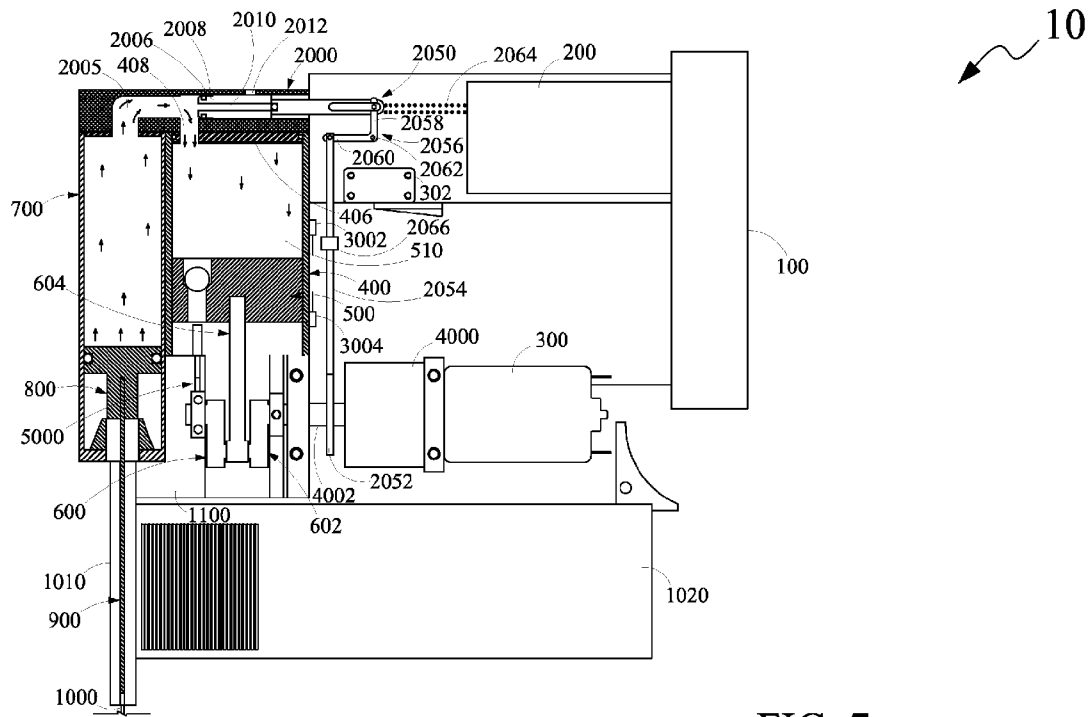

FIG. 7

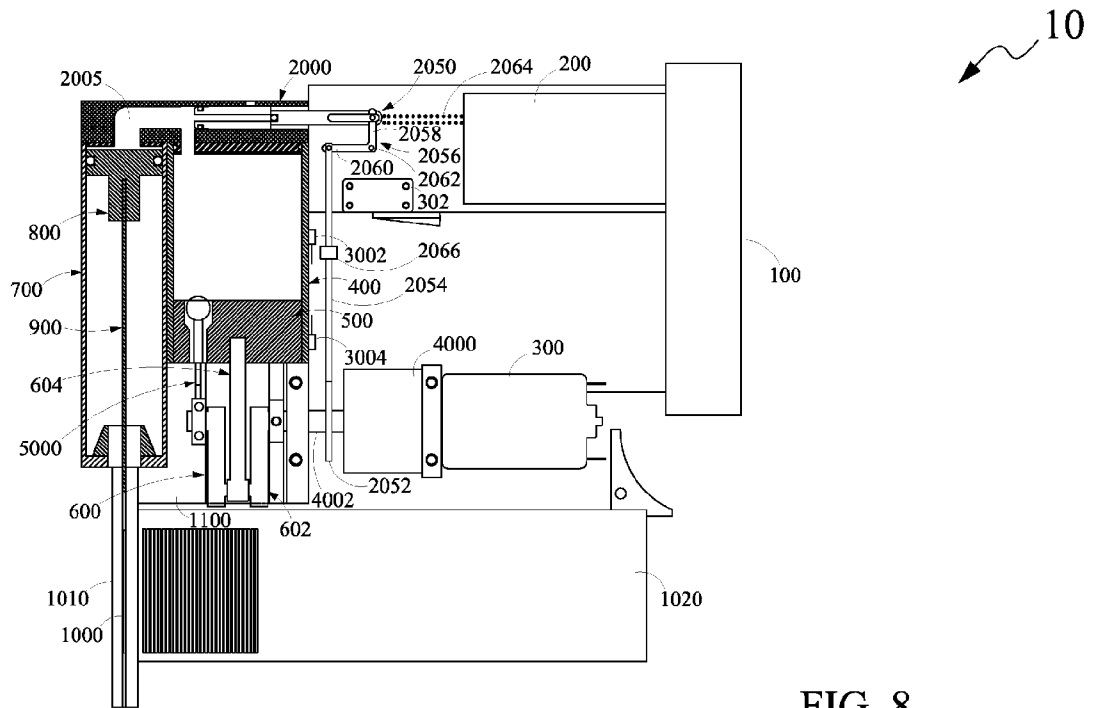

FIG. 8

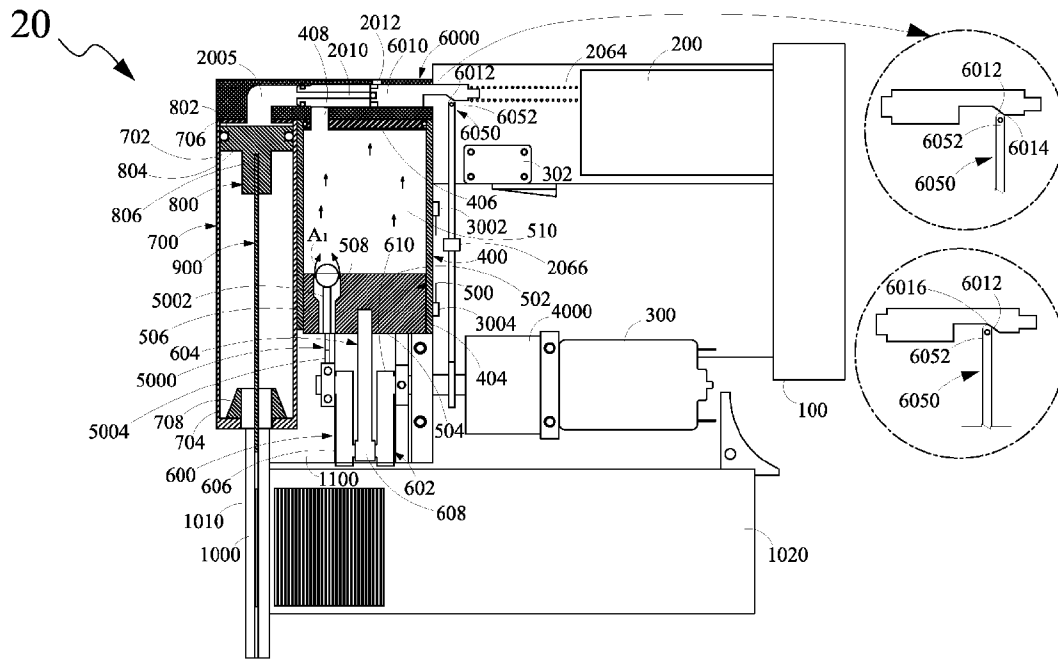

FIG. 9

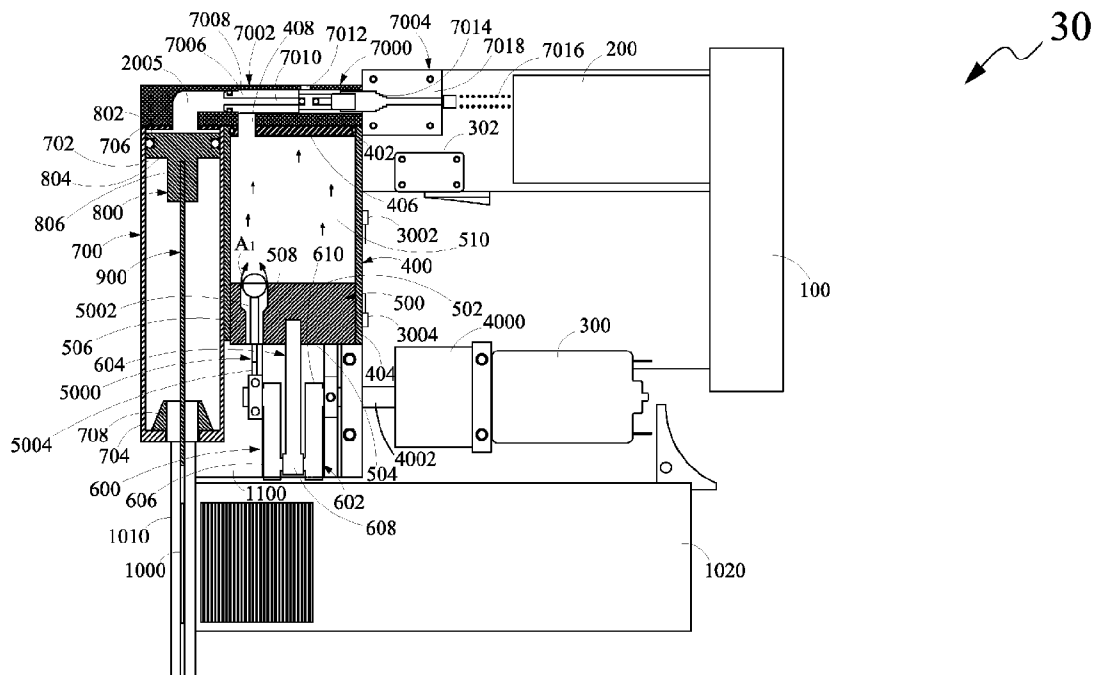

FIG. 10

## FASTENER DRIVING APPARATUS

**Matter enclosed in heavy brackets [ ] appears in the original patent but forms no part of this reissue specification; matter printed in italics indicates the additions made by reissue.**

## CROSS REFERENCE TO RELATED APPLICATIONS

The present invention claims priority under 35 United States Code, Section 119 on the U.S. Provisional Patent Application numbered 61/208,556 filed on Feb. 25, 2009, the disclosure of which is incorporated by reference.

## FIELD OF THE DISCLOSURE

The present disclosure generally relates to apparatuses for driving fasteners into workpiece, and more particularly, to a fastener driving apparatus used as a portable hand tool.

## BACKGROUND OF THE DISCLOSURE

A fastener driving apparatus is a tool used to drive fasteners, such as nails and staples into a workpiece. The fastener driving apparatus may be used for various operations, such as making wooden walls, positioning hang sheathings over the wooden walls, fastening baseboards over a lower portion of an interior wall and crown molding.

There are various fastener driving apparatuses known in the art. These fastener driving apparatuses operate utilize various means and mechanisms known in the art for their operation. For example, the prior art fastener driving apparatuses may be operated based on compressed air generated by an air compressor, fuel cells, electrical energy, a flywheel mechanism, and the like.

Although these fastener driving apparatuses are useful in driving the fasteners into the workpiece, such apparatuses have numerous limitations. For example, the fastener driving apparatuses operated on the compressed air are bulkier, non-portable and costlier due to requirement of the air compressor and associated air-lines. Fastener driving apparatuses operated on the fuel cells are complicated in design and are expensive. Further, the apparatuses that are operated on the fuel cells require both electrical energy and fuel. More specifically, a spark source required for combustion of the fuel derives its energy from various electric energy sources such as batteries, and the like. Furthermore, the fastener driving apparatuses operated on the fuel cells generate loud report and release of combustion products.

Further, the fastener driving apparatuses operated on the electrical energy are limited to fasteners of relatively small lengths, such as one inch or less. Further, the fastener driving apparatuses operated on the electrical energy generate high reactionary force. The high reactionary force is a consequence of the comparatively longer time taken by such fastener driving apparatuses to drive the fasteners into the workpiece. Further, the fastener driving apparatuses operated on the electrical energy are limited in their repetition rate because of long time it takes to drive a fastener into the workpiece. Moreover, although fastener driving apparatuses operated by flywheels are capable of driving the fasteners of longer sizes very quickly, these apparatuses are bulkier in sizes and weight. Further, drive mechanisms of these apparatuses are complicated in design, which results in a high cost of such apparatuses.

Additionally, a majority of the above-mentioned fastener driving apparatuses includes a striker mechanism for driving the fasteners into the workpiece. The striker mechanism may be retracted to its initial position by means of various retracting mechanisms, such as a spring, a bungee and the like. Although such striker mechanisms are useful in driving the fasteners into the workpiece, these retracting mechanisms have numerous limitations. For example, the retracting mechanisms, due to inertia associated therewith, consume significant drive energy of the fastener driving apparatuses and may prevent the fasteners from being fully driven into the workpiece. Accordingly, these retracting mechanisms may require an increase in power to drive the fasteners into the workpiece. Further, these retracting mechanisms reduce drive speed of the fastener driving apparatuses. Furthermore, the existing retracting mechanisms may bias the striker mechanism towards the workpiece, causing a safety hazard for the user.

Based on the foregoing, there exists a need for a fastener driving apparatus employing a retracting mechanism that precludes consumption of drive energy of the fastener driving apparatus and facilitates a fastener to be fully driven into a workpiece. The fastener driving apparatus should have the retracting mechanism capable of precluding reduction of drive speed of the fastener driving apparatus and should be capable of providing safety to a user. Further, the fastener driving apparatus should be portable in nature and should be capable of driving the fastener into the workpiece in a single stroke.

## SUMMARY OF THE DISCLOSURE

In view of the foregoing disadvantages inherent in the prior art, the general purpose of the present disclosure is to provide a fastener driving apparatus that is configured to include all the advantages of the prior art, and to overcome the drawbacks inherent therein.

Accordingly, an object of the present disclosure is to provide a fastener driving apparatus employing a retracting mechanism that precludes consumption of drive energy and reduction in drive speed of the fastener driving apparatus and facilitate a fastener to be fully driven into a workpiece.

Another object of the present disclosure is to provide a fastener driving apparatus that is portable in nature and is capable of providing more safety to a user.

Yet another object of the present disclosure is to provide a fastener driving apparatus that is capable of driving a fastener into a workpiece in a single stroke and is capable of increasing efficiency of the fastener driving apparatus.

Still another object of the present disclosure is to provide a fastener driving apparatus that is capable of minimizing reactionary force generated during fastener driving operation.

In light of the above objects, a fastener driving apparatus for driving a fastener into a workpiece is disclosed. The fastener driving apparatus includes a power source, a control circuit, a motor, a first cylinder, a first piston, a linear motion converter, a second cylinder, a second piston, an anvil, a valve arrangement and at least one sensor. The control circuit is electrically coupled to the power source. The motor is electrically coupled to the power source and is responsive to the control circuit.

The first piston is reciprocally movable within the first cylinder to execute a compression stroke and a return stroke. The first piston is configured to define a gas chamber within the first cylinder. The gas chamber is capable of accommodating gas therein. The first piston is operationally coupled to the linear motion converter. The linear motion converter is

driven by the motor. The linear motion converter is configured to reciprocally move the first piston within the first cylinder. The first cylinder is pneumatically connected to the second cylinder. The second piston is reciprocally movable within the second cylinder. The anvil is coupled to the second piston. The anvil is capable of striking the fastener to drive the fastener into the workpiece. The valve arrangement is operationally disposed between the first cylinder and the second cylinder for pneumatically connecting the first cylinder and the second cylinder. The valve arrangement is configured to define a gas passageway between the first cylinder and the second cylinder in an open position. Further, the valve arrangement is also configured to block the gas passageway in a closed position. The at least one sensor is communicably coupled to the control circuit. The at least one sensor is configured to detect at least one position of the operation cycle and communicate the detected position of the operation cycle to the control circuit. The control circuit is configured to stop an operation cycle of driving the fastener into the workpiece based on the detected position by the at least one sensor.

The control circuit is configured to actuate the valve arrangement to configure one of the open position and the closed position based on the detected position of the first piston.

During the compression stroke, the first piston is configured to move towards a top dead center of the first cylinder thereby compressing the gas in the gas chamber to a predetermined pressure. Further, the valve arrangement assumes the open position at the predetermined pressure for communicating the compressed gas to the second cylinder. The compressed gas communicated to the second cylinder causes the second piston to move linearly and enables the anvil to drive the fastener into the workpiece. During the return stroke, the valve arrangement assumes the closed position and the first piston is configured to move towards a bottom dead center of the first cylinder thereby creating a vacuum in the first cylinder between the top dead center of the first cylinder and the first piston. At a predetermined position of the first piston during the return stroke, the valve arrangement assumes the open position. The open position of the valve arrangement causes the vacuum created in the first cylinder to communicate to the second cylinder, thereby causing the second piston and the anvil to retract to initial positions of the second piston and the anvil.

This aspect together with other aspects of the present disclosure, along with the various features of novelty that characterize the present disclosure, are pointed out with particularity in the claims annexed hereto and form a part of this present disclosure. For a better understanding of the present disclosure, its operating advantages, and the specific objects attained by its uses, reference should be made to the accompanying drawings and descriptive matter in which there are illustrated exemplary embodiments of the present disclosure.

#### BRIEF DESCRIPTION OF THE DRAWINGS

The advantages and features of the present disclosure will become better understood with reference to the following detailed description and claims taken in conjunction with the accompanying drawings, in which:

FIG. 1 illustrates a longitudinal cross-sectional view of a fastener driving apparatus depicting an initial stage of an operation cycle of driving a fastener from the fastener driving apparatus, in accordance with an embodiment of the present disclosure;

FIG. 2 illustrates a longitudinal cross-sectional view of the fastener driving apparatus depicting compression of gas in a

gas chamber to a predetermined pressure, in accordance with an embodiment of the present disclosure;

FIGS. 3 and 4 illustrate longitudinal cross-sectional views of the fastener driving apparatus depicting rapidly expanding gas driving a second piston and an anvil in a downward direction for driving the fastener into a workpiece, in accordance with an embodiment of the present disclosure;

FIG. 5 illustrates a longitudinal cross-sectional view of the fastener driving apparatus depicting a closed position of a valve arrangement and a first piston performing a return stroke, in accordance with an embodiment of the present disclosure;

FIG. 6 illustrates a longitudinal cross-sectional view of the fastener driving apparatus depicting the closed position of the valve arrangement and the first piston generating vacuum in a first cylinder, in accordance with an embodiment of the present disclosure;

FIG. 7 illustrates a longitudinal cross-sectional view of the fastener driving apparatus depicting an open position of the valve arrangement communicating the vacuum created in the first cylinder to the second cylinder for retracting the second piston and the anvil to their initial positions, in accordance with an embodiment of the present disclosure;

FIG. 8 illustrates a longitudinal cross-sectional view of the fastener driving apparatus depicting vacuum retracted initial positions of the second cylinder and the anvil, in accordance with an embodiment of the present disclosure;

FIG. 9 illustrates a longitudinal cross-sectional view of the fastener driving apparatus, in accordance with another embodiment of the present disclosure; and

FIG. 10 illustrates a longitudinal cross-sectional view of the fastener driving apparatus, in accordance with yet another embodiment of the present disclosure.

Like reference numerals refer to like parts throughout the description of several views of the drawings.

#### DETAILED DESCRIPTION OF THE DISCLOSURE

The exemplary embodiments described herein detail for illustrative purposes are subject to many variations in structure and design. It should be emphasized, however, that the present disclosure is not limited to a particular fastener driving apparatus as shown and described. It is understood that various omissions and substitutions of equivalents are contemplated as circumstances may suggest or render expedient, but these are intended to cover the application or implementation without departing from the spirit or scope of the claims of the present disclosure.

The terms "first," "second," and the like, herein do not denote any order, quantity, or importance, but rather are used to distinguish one element from another, and the terms "a" and "an" herein do not denote a limitation of quantity, but rather denote the presence of at least one of the referenced item.

The present disclosure provides a fastener driving apparatus for driving fasteners into a workpiece. As used herein, the term "fastener" refers to, but is not limited to, a nail, a staple, and the like. Further, the term "gas" as used herein, refers to, but is not limited to "atmospheric air". Herein, the terms "gas" and "air" are interchangeably used throughout the description. Furthermore, an 'operation cycle' of driving a fastener refers to steps involved in driving the fastener completely into a workpiece from the fastener driving apparatus. The operation cycle may also be termed as a combination of a "compression stroke" and a "return stroke" of a first piston.

The fastener driving apparatus, disclosed in the present disclosure, includes a power source, a control circuit, a motor, a first cylinder, a first piston, a linear motion converter, a second cylinder, a second piston, an anvil, a valve arrangement and at least one sensor. The first piston is reciprocally movable within the first cylinder to execute a compression stroke and a return stroke. The first piston executes the compression stroke and return stroke with help of the motor and the linear motion converter. Operation of the motor is further controlled by the control circuit. The valve arrangement is configured to pneumatically connect the first cylinder and the second cylinder. The valve arrangement assumes one of an open position and a closed position during an operation cycle of driving a fastener into the workpiece. In the open position of the valve arrangement, the valve arrangement defines a gas passageway allowing any communication of gas between the first cylinder and the second cylinder. Further, in the closed position of the valve arrangement, the gas passageway is blocked to stop any communication of gas between the first and second cylinders.

During the compression stroke of the first piston in the first cylinder, the first piston is configured to move towards a top dead center of the first cylinder, thereby compressing gas in a gas chamber formed above an upper face of the first piston in the first cylinder to a predetermined pressure or a predetermined stroke of the first piston. Further, the valve arrangement assumes the open position at the predetermined pressure or the predetermined stroke and allows the compressed gas to communicate to the second cylinder. The compressed gas communicated to the second cylinder causes the second piston disposed in the second cylinder to move linearly. The anvil is coupled to the second piston. The anvil also moves linearly with the movement of the second piston and strikes the fastener thereby driving the fastener into the workpiece.

During the return stroke of the first piston in the first cylinder, the valve arrangement assumes the closed position, and the first piston is configured to move towards a bottom dead center of the first cylinder. Movement of the first piston towards the bottom dead center of the first cylinder creates a vacuum between the top dead center of the first cylinder and the first piston. When the first piston reaches a predetermined position in the first cylinder during the return stroke, the valve arrangement assumes the open position. The open position of the valve arrangement causes the vacuum created in the first cylinder to communicate to the second cylinder and thereby causes the second piston and the anvil to retract to their initial positions. Further, the fastener driving apparatus becomes ready for driving a next fastener from the fastener driving apparatus. The working mechanism and configuration of the fastener driving apparatus of the present disclosure is described herein in conjunction with FIGS. 1 to 8.

Referring to FIGS. 1 to 8, longitudinal cross-sectional views of a fastener driving apparatus 10 are illustrated. An operation cycle for driving a fastener 1000 from the fastener driving apparatus 10 will be described in conjunction with FIGS. 1 to 8. Referring particularly to FIG. 1, the fastener driving apparatus 10 includes a power source 100, a control circuit 200, a motor 300, a first cylinder 400, a first piston 500, a linear motion converter 600, a second cylinder 700, a second piston 800, an anvil 900, a valve arrangement 2000 and a pair of sensors 3002, 3004.

The power source 100 is configured to provide power for working of the fastener driving apparatus 10. The power source 100 may be a rechargeable battery, a battery pack, or any other power source such as an AC power supply. The power source 100 is electrically coupled to the control circuit 200. The power source 100 may be electrically coupled to the

control circuit 200 by means of wired, wireless means or any other mechanism known in the art.

The control circuit 200 is configured to actuate the power source 100 for initiating the operation cycle for driving the fastener 1000. Similarly, the control circuit 200 is configured to deactivate the power source 100 after completion of the operation cycle. The control circuit 200 may be any of the various control circuits known in the art. In one embodiment of the present disclosure, the control circuit 200 may include a microprocessor, plurality of high power switching elements and control circuit inputs. Further, in another embodiment of the present disclosure, the control circuit 200 may include a limit switch coupled to cams and linkages. Further, the control circuit 200 may be configured to receive input signals from timers, sensors, and the like. Furthermore, the control circuit 200 may also be configured to provide an output signal to an interface, a LED, and the like. Moreover, in one embodiment of the present disclosure, the control circuit 200 may include at least one low battery indicator, a pulse control of motor power, a plurality of communication ports, a status display indicator, a fault lockout protection controller, and the like. The control circuit 200 is configured to control the working of the motor 300 by activating or deactivating the power source 100.

The motor 300 is electrically connected to the power source 100. The motor 300 may be electrically connected to the power source 100 by means of various means and mechanisms, such as an electric wire or a magnetic coupling. The motor 300 is further responsive to the control circuit 200. More specifically, the control circuit 200 is configured to direct the power from the power source 100 to the motor 300 for initiating the operation cycle of driving the fastener such as the fastener 1000 into the workpiece. Similarly, the control circuit 200 is configured to disconnect the power from the power source 100 to the motor 300 after completion of the operation cycle. In one embodiment of the present disclosure, the motor 300 may include a dynamic braking system for halting the rotations of the motor 300. Further, in one embodiment of the present disclosure, the fastener driving apparatus 10 may include a switch 302 for directing and disconnecting the power from the power source 100 to the motor 300 through the control circuit 200. More specifically, the switch 302 may be controlled by the control circuit 200 for appropriately actuating the starting and stopping of the operation cycle of fastener drive apparatus 10. The switch 302 may be an ON/OFF switch. The motor 300 is configured to impart a reciprocating movement to the first piston 500 in the first cylinder 400. The motor 300 provides the reciprocating movement to the first piston 500 through the linear motion converter 600. The linear motion converter 600 is configured to convert the rotational motion of the motor 300 into linear reciprocating movement of the first piston 500 within the first cylinder 400.

The linear motion converter 600 is driven by the motor 300. Without departing from the scope of the present disclosure, the linear motion converter 600 may be driven by the motor 300 through a speed reduction mechanism 4000. The speed reduction mechanism 4000 is configured to reduce the revolutions per minute (rpm) of the motor 300 depending upon a required speed of reciprocating movement of the first piston 500. In one embodiment of the present disclosure, the speed reduction mechanism 4000 may be a gear reduction mechanism. The speed reduction mechanism 4000 is connected to the linear motion converter 600 through a shaft 4002. In the present embodiment of the present disclosure, the linear motion converter 600 is shown as a crankshaft mechanism.

Herein, the linear motion converter **600** includes a crankshaft **602** and a connecting rod **604** connected to the crankshaft **602**.

The crankshaft **602** includes a first end portion **606**, a middle portion **608** and a second end portion **610**. The first end portion **606** of the crankshaft **602** is connected to a body portion **1100** of the fastener driving apparatus **10** and the second end portion **610** is coupled to the shaft **4002** that is coupled to the speed reduction mechanism **4000**. The body portion **1100** refers to a structural framework on which various components of the fastener driving apparatus **10** may be disposed. Further, the speed reduction mechanism **4000** is coupled to the second end portion **610** of the crankshaft **602** for transmitting the rotational motion generated by the motor **300** to the crankshaft **602** and the connecting rod **604**. The connecting rod **604** is connected to the middle portion **608** of the crankshaft **602**. An upper end portion **612** of the connecting rod **604** is connected to the first piston **500**. In one embodiment of the present disclosure, the upper end portion **612** of the connecting rod **604** is connected to the first piston **500** by means of a piston pin (not shown). Further, a lower end portion **614** of the connecting rod is connected to the middle portion **608** of the crankshaft **602**. The lower end portion **614** of the connecting rod **604** may be connected to the middle portion **608** of the crankshaft **602** by means of various means and mechanisms, such as a nut and a bolt, a rivet, and the like.

Although, in the embodiment of the present disclosure shown in FIG. 1, the linear motion converter **600** is described in accordance with the crankshaft mechanism, but the linear motion converter **600** may include other arrangements, such as a slider crank arrangement, a rack and pinion arrangement, a lead screw arrangement, and the like.

Further, the first cylinder **400** of the fastener driving apparatus **10** includes an upper end portion **402**, a lower end portion **404** and a cylinder end cap **406**. The cylinder end cap **406** is configured on the upper end portion **402**. The cylinder end cap **406** further includes an opening **408** configured thereon. The first cylinder **400** may have a volume that is proportional to the amount of energy required for driving the fastener **1000** into the workpiece. In one embodiment of the present disclosure, for driving an 18 gage fastener, the volume of the first cylinder **400** may be around 8 to 12 cubic inch at standard atmospheric temperature and pressure conditions.

The first piston **500** is disposed within the first cylinder **400**. The first piston **500** includes an upper face **502**, a lower face **504**, a body portion **506** and a check valve **508**. Further, the first piston **500** is configured to define a gas chamber **510** within the first cylinder **400**. More specifically, the first piston **500** is configured to define the gas chamber **510** between the upper face **502** of the first piston **500** and the cylinder end cap **406** of the first cylinder **400**. The gas chamber **510** is capable of accommodating gas therein. The first piston **500** is configured to reciprocally move within the first cylinder **400** to execute the compression stroke and the return stroke. During the compression stroke, the first piston **500** is configured to move from the lower end portion **404**, i.e., Bottom Dead Center (BDC) of the first cylinder **400** to the upper end portion **402**, i.e., Top Dead Center (TDC) of the first cylinder **400**. Further, during the return stroke, the first piston **500** is configured to move from the upper end portion **402** (TDC) of the first cylinder **400** to the lower end portion **404** (BDC) of the first cylinder **400**.

Before starting the compression stroke, the gas chamber **510** may have a volume of the gas stored therein, which is proportional to the amount of energy required for driving the fastener **1000** into the workpiece. In one specific embodiment of the present disclosure, for driving the 18 gage fastener, the

gas chamber **510** may have a volume of about 9 to 11 cubic inches, before starting the compression stroke at standard atmospheric pressure and temperature conditions. More specifically, in this embodiment, for driving the 18 gage fastener, the gas chamber **510** may have a volume of about 10 cubic inches at standard atmospheric pressure and temperature conditions. The gas stored in the gas chamber **510** is prevented from flowing towards the lower face **504** of the first piston **500**, as the check valve **508** assumes the closed position.

The check valve **508** is disposed in the body portion **506**. More specifically, the check valve **508** may be disposed on a side portion of the body portion **506**. However, the present disclosure is not limited to a particular disposition of the check valve **508** within the body portion **506**. The check valve **508** is a unidirectional valve configured to allow atmospheric air to flow into the first cylinder **400** in an open position.

As shown in FIG. 1, the fastener driving apparatus **10** includes a vertical actuation member **5000** for the actuation of the check valve **508**. The vertical actuation member **5000** may be disposed on the body portion **1100** of the fastener driving apparatus **10**. More specifically, the vertical actuation member **5000** may be disposed adjacent to the connection of the first end portion **606** of the crankshaft **602** to the body portion **1100**. The vertical actuation member **5000** includes a first end portion **5002** and a second end portion **5004**. The first end portion **5002** of the vertical actuation member **5000** is connected to the body portion **1100**. The second end portion **5004** is configured to actuate the check valve **508** to configure the open position of the check valve **508**, when the first piston **500** reaches the lower end portion **404** of the first cylinder **400**. In one embodiment, the check valve **508** may be configured such that when the crankshaft **602** rotates till 30 degrees from a starting point of the crankshaft **602**, the gas chamber **510** is replenished with the atmospheric air. Herein, the starting point of the crankshaft **602** refers that when the crankshaft **602** is at the starting point, the first piston **500** is at the BDC of the first cylinder **400**.

In another embodiment, instead of using the check valve **508**, the diameter of the lower end portion **404** of the first cylinder **400** may be larger than remaining portion of the first cylinder **400**. Further, the first piston **500** may include O rings formed on lateral surfaces thereof. When the first piston **500** moves towards the TDC of the first cylinder **400** from the BDC of the first cylinder **400**, there are inlets formed between either sides of the first piston **500** and the lower end portion **404** of the first cylinder **400**. The atmospheric air enters the gas chamber **510** through the inlets. Further, during the movement of the first piston **500** towards the TDC, when the O rings go past the lower end portion **404**, i.e., an enlarged section of the first cylinder **400**, the inlets are closed as O rings come in physical contact with walls of the remaining portion of the first cylinder **400**. In one embodiment, positioning of the O rings on the first piston **500** and the dimensions of the lower end portion **404** may be such that with the rotation of the crankshaft **602** by 30 degrees from the starting point of the crankshaft **602**, the gas chamber **510** is replenished with the atmospheric air.

Further, the fastener driving apparatus **10** may include at least one sensor such as a first sensor **3002** and a second sensor **3004**, configured to detect at least one position of the operation cycle and communicate the detected position of the operation cycle to the control circuit. A sensor, such as a first sensor **3002** and a second sensor **3004**, may be disposed anywhere within or on the apparatus that facilitates the sensor in determining the operation cycle of the apparatus. In a non-limiting embodiment, a first sensor **3002** and a second sensor **3004** are disposed on the first cylinder **400**. More

specifically, the first sensor **3002** is disposed on the upper end portion **402** of the first cylinder **400** and the second sensor **3004** is disposed on the lower end portion **404** of the first cylinder **400**. The sensors **3002** and **3004** are communicably coupled to the control circuit **200**. The sensors **3002** and **3004** are communicably coupled to the control circuit **200** by means of various wired or wireless means known to the person skilled in the art. Further, in an embodiment, the sensors **3002** and **3004** are configured to detect at least one position of the first piston **500**. More specifically, the first sensor **3002** is configured to detect position of the first piston **500** when the first piston **500** approaches the TDC of the first cylinder **400**. Similarly, the second sensor **3004** is configured to detect position of the first piston **500** when the first piston **500** approaches the BDC of the first cylinder **400**. Further, the first sensor **3002** and the second sensor **3004** are configured to communicate the detected position of the first piston **500** to the control circuit **200**. Based on the detected position by the sensor **3004**, the control circuit **200** is configured to disconnect the power source **100** from the motor **300** to stop the operation cycle. It will be apparent that at least one sensor **3000** of the present disclosure may be configured at any location in or on the apparatus that causes the sensor discern a position of a component or components of the apparatus for determining a position of the operation cycle of the apparatus. In one embodiment, the control circuit **200** is configured to actuate the valve arrangement **2000** to configure one of the open position and the closed position based on the detected position of the first piston **500**.

The sensors **3002** and **3004** may be selected from, but not limited to, one of or a combination of a limit switch, a Hall Effect sensor, a photo sensor, a reed switch, a timer and a current or voltage sensor without departing from the scope of the disclosure. The sensors **3002** and **3004** may also include Hall sensors combined with at least one magnet. The sensors **3002** and **3004** are shown as disposed on the upper end portion **402** and the lower end portion **404** in FIG. 1, however this disposition should not be considered limiting. In another embodiment, the pair of sensors **3000** may also be disposed on the first piston **500**.

Further, the valve arrangement **2000** is operationally disposed between the first cylinder **400** and the second cylinder **700**. The valve arrangement **2000** is disposed in a manner such that the valve arrangement **2000** acts as a medium for communicating gas between the first cylinder **400** and the second cylinder **700**. The valve arrangement **2000** is configured to assume one of the open position and the closed position. The valve arrangement **2000** is configured to define a gas passageway **2005** between the first cylinder **400** and the second cylinder **700** in the open position. In one embodiment of the present disclosure, a volume of the gas passageway **2005** is less than 15% of the volume of the first cylinder **400**. The volume of the gas passageway **2005** may be less than 15% of the volume of the first cylinder **400** for minimizing losses related to accumulation of the gas in the gas passageway **2005**, and thereby increasing the efficiency of the fastener driving apparatus **10**. The valve arrangement **2000** is configured to block the gas passageway **2005** in the closed position of the valve arrangement **2000**.

The valve arrangement **2000** includes a valve spool **2006** and a valve body **2008**. The valve spool **2006** is slidably disposed in the valve body **2008**. The valve spool **2006** may include an elongated groove **2010** configured on a central portion thereof. Further, in one embodiment of the present disclosure, the valve spool **2006** may be held in position by means of a spring (not shown) and pressure balance between two o-rings (not shown). The valve body **2008** may further

include an vent opening **2012** configured thereon. In the closed position of the valve arrangement **2000**, the vent opening **2012** is configured to receive gas from the elongated groove **2010** and pass the gas to atmosphere.

The valve arrangement **2000** assumes the open position and the closed position by utilizing a coupling member **2050**. The coupling member **2050** is operably coupled between the motor **300** and the valve arrangement **2000**. In one embodiment, the coupling member **2050** may be operatively connected between the speed reduction mechanism **4000** and the valve spool **2006**. The coupling member **2050** is configured such that it imparts a linear movement to the valve spool **2006** in response to the rotation movement of the motor **300** for covering/uncovering the opening **408**, thereby defining the gas passageway **2005**. Accordingly, the valve arrangement **2000** may assume the open position or the closed position.

In one embodiment, the coupling member **2050** may include a cam **2052**, a pushrod **2054**, a rocker arm **2056** and a cam guide **2066**. In one form, the cam **2052** may be coupled to the shaft **4002** that is coupled to the speed reduction mechanism **4000**, so that the cam **2052** may rotate about axis of the shaft **4002**. The pushrod **2054** operably couples the cam **2052** to the rocker arm **2056**. The rocker arm **2056** has a first arm **2058** and a second arm **2060**. The first arm **2058** is connected to a rear portion of the valve spool **2006** and the second arm **2060** is connected to the pushrod **2054**. The first arm **2058** and the second arm **2060** are pivotally connected to each other at a pivot point **2062**. Further, the second arm **2060** is also pivotally connected to the pushrod **2054**. The cam guide **2066** guides the upward and downward movement of the pushrod **2054**.

The cam **2052** has a suitable profile such that with the rotation of the cam **2052**, the pushrod **2054** is moved towards and away from the shaft **4002** and acts on the rocker arm **2056** such that the rocker arm **2056** actuates the valve spool **2006** for the valve arrangement **2000** to assume the open position and the closed position. In one form, the cam **2052** has a profile having two rises and two falls in 360 degrees rotation about the shaft **4002** in one operation cycle. When the pushrod **2054** is pushed away from the shaft **4002**, the pushrod **2054** pushes the second arm **2060** to rotate in a clockwise manner about the pivot point **2062**. Due to the clockwise rotation of the second arm **2060** about the pivot point **2062**, the first arm **2058** pulls the valve spool **2006** away from the opening **408** and compresses a valve spool return spring **2064**. Accordingly, the valve spool **2006** unblocks the opening **408**, thereby causing the valve arrangement **2000** to assume the open position.

Further, with the rotation of the cam **2052** and due to a fall profile of the cam **2052**, the pushrod **2054** comes towards the shaft **4002**, thereby causing the second arm **2060** to make a counter clockwise rotation about the pivot point **2062**. Further, the first arm **2058** moves away from the valve spool return spring **2064**, which is in compressed state. The release of the valve spool return spring **2064** further helps the valve spool **2006** to come toward the opening **408** and thereby closes the opening **408**. Accordingly, the valve arrangement **2000** assumes the closed position. In one embodiment, the valve spool **2006** includes a slot **2070** configured in the rear portion of the valve spool **2006**. In this embodiment, the valve spool return spring **2064** which is in compressed state when the valve arrangement **2000** is in open position, expands and pushes the valve spool **2006** to cover the opening **408**. In this embodiment, the first arm **2058** moves within the slot **2070**. The slot **2070** provides the valve spool **2006** for lost motion control as the valve spool **2006** opens at high speed in relation to speed of the rocker arm **2056**. More specifically, the slot

2070 allows the valve spool 2006 to open rapidly after the valve spool 2006 is tripped by the rocker arm 2056.

In one embodiment of the present disclosure, the valve arrangement 2000 has a flow coefficient (Cv) greater than one. The flow coefficient describes the relationship between the pressure drop across a valve and corresponding flow rate. A valve arrangement having higher flow coefficient provides a larger flow of gas through valve arrangement at a given pressure drop. Further, the valve arrangement 2000 is configured as a snap acting valve. The snap acting valve may be defined as a valve that has an opening time of less than 20 milliseconds. Herein, the opening time of the valve represents a time involved in opening of the valve from the initial closed position to a position at which about 70 percent of full flow of the compressed gas in the valve may be achieved.

The second cylinder 700 is pneumatically connected to the first cylinder 400 via the valve arrangement 2000. The second cylinder 700 is positioned parallel to the first cylinder 400. The second cylinder 700 acts as an expansion cylinder, where the compressed gas within the first cylinder 400 is allowed to expand when the valve arrangement 2000 assumes the open position after the compression stroke of the first piston 500. The second cylinder 700 includes a proximal end portion 702, a distal end portion 704 and a top plate 706. Further, a bumper 708 may be disposed in the distal end portion 704 of the second cylinder 700. The bumper 708 is configured to absorb excess energy at the end of an expansion stroke, i.e., when the anvil 900 strikes the fastener 1000. The bumper 708 may be composed of various impact energy absorbing materials, such as an elastomer, and the like.

The second piston 800 is disposed within the second cylinder 700. The second piston 800 is configured to reciprocally move within the second cylinder 700. The anvil 900 is coupled to a rear face 804 of the second piston 800 by means of a connector 806 coupled to the rear face 804. The connector 806 may be coupled to the rear face 804 by means of various means and mechanisms, such as a nut and bolt arrangement, a rivet, welding and other arrangements known in the art. The anvil 900 may be secured in a central groove (not shown) of the connector 806, by use of suitable means, such as a nut and bolt arrangement, a rivet, welding, and the like known in the art. Further, in one embodiment of the present disclosure, the connector 806 and the anvil 900 may also be configured as a single unit.

The anvil 900 is configured to reciprocally move along with the second piston 800. The anvil 900 is capable of linearly moving within the second cylinder 700 and a fastener guide 1010. Further, the anvil 900 is capable of striking the fastener 1000 to drive the fastener 1000 into the workpiece. The fastener guide 1010 is configured to receive the fastener 1000 from a fastener feeder 1020.

Further, in one embodiment of the present disclosure, the second cylinder 700 may further include a second bumper disposed on the proximal end portion 702 of the second cylinder 700 for absorbing excess energy when the second piston 800 is retracted to its initial position. Furthermore, in one embodiment of the present disclosure, the second cylinder 700 may include an o-ring or a recess in the top plate 706 for maintaining the second piston 800 and the anvil 900 to their initial positions (pre-fastener driving positions as shown in FIG. 1). Moreover, in one embodiment of the present disclosure, the second cylinder 700 may include a magnet disposed on the top plate 706 and a piece of ferrous material in the anvil 900 for maintaining the second piston 800 and the anvil 900 to their initial positions. Accordingly, by maintaining the second piston 800 and the anvil 900 in their upper positions and ensuring that there is little or no extra dead

volume between the second piston 800 and the top plate 706, maximum efficiency may be achieved as the expansion of the gas after the compression stroke acts directly on the second piston 800. Further, such arrangement precludes any accidental release of the anvil 900 and thereby facilitates more safety to the user.

The operation cycle of the fastener driving apparatus 10 is shown in a progressive manner in FIGS. 1 to 8, and will now be described with reference to FIGS. 1 to 8.

Referring again to FIG. 1, a first stage of the operation cycle of the fastener driving apparatus 10 is shown. At this stage of the operation cycle, the first piston 500 is at the BDC of the first cylinder 400, and the second piston 800 and the anvil 900 are at the proximal end portion 702 of the second cylinder 700, the valve arrangement 2000 is in the closed position, the fastener 1000 is disposed in the fastener guide 1010 and the motor 300 is in an OFF state. Positioning of the second piston 800 and the anvil 900 at the proximal end portion 702 represent 'initial positions' of the second piston 800 and the anvil 900 at the beginning of the operation cycle. As the first piston 500 is at the BDC, the vertical actuation member 5000 keeps the check valve 508 in the open position. In the open position of the check valve 508, the atmospheric air gets filled in the gas chamber 510 from the check valve 508 as shown by arrows 'A1' in FIG. 1. Alternatively, in another embodiment of the present disclosure, the atmospheric air may be filled in the gas chamber 510 by means of the series of holes or the enlarged opening configured in the lower end portion 404 of the first cylinder 400. Further, the check valve 508 in its closed position prevents any exit of gas from the gas chamber 510.

Further, for initiating the operation cycle of the fastener driving apparatus 10, the user may actuate the switch 302. The control circuit 200 by means of the second sensor 3004 ensures that the first piston 500 is at the BDC of the first cylinder 400. After ensuring that the first piston 500 is at the BDC of the first cylinder 400, the control circuit 200 actuates the power source 100 to supply power to the motor 300. The motor 300 then drives the linear motion converter 600, which in turn facilitates the first piston 500 to execute the compression stroke. The valve arrangement 2000 is in the closed position and the first piston 500 moves from the lower end portion 404, i.e., BDC of the first cylinder 400 towards the upper end portion 402, i.e., TDC of the first cylinder 400. Further, as the first piston 500 moves towards the TDC, the vertical actuation member 5000 causes the check valve 508 to assume the closed position. More specifically, due to a pressure difference on both sides of the check valve 508 (inside and outside of the first cylinder 400), the check valve 508 is configured to assume the closed position. Further, as valve arrangement 2000 is in the closed position, the first piston 500 compresses the gas in the gas chamber 510. During the compression stroke, due to the cam rise profile of the cam 2052 that is rotating, the second arm 2060 starts rotating in the clockwise direction about the pivot point 2062. Accordingly, the first arm 2058 starts pulling the valve spool 2006 rearward in order to uncover the opening 408. Further, the valve spool return spring 2064 also starts compressing as the valve spool 2006 moves rearward.

Further, as shown in FIG. 2, as the first piston 500 reaches the TDC of the first cylinder 400, the gas is compressed to a predetermined pressure. In one embodiment of the present disclosure, for driving a standard 18 gages and 2 inches long fastener 1000, the gas in the gas chamber 510 may be compressed to a predetermined pressure of 160 psi (pounds per square inch) with a volume of the compressed gas being approximately one cubic inch. The first piston 500 is config-

ured to compress the gas in the gas chamber 510 at the predetermined pressure in a single rapid linear stroke, i.e., the compression stroke. By compressing the gas in the gas chamber 510 in the single rapid linear stroke, the gas is compressed in a way such that the pressure of the compressed gas exceeds a pressure that will be predicted by the formula  $P_1V_1=P_2V_2$ . Herein,  $P_1$  and  $P_2$  represent pressure of the gas and  $V_1$  and  $V_2$  represent volume of the gas. Such increase in the pressure may be modeled with a compression exponent greater than 1.05. Compression exponents greater than 1.05 yield higher gas pressures for a given compression ratio than the gas pressure for a compression done in a normal manner. More specifically, such a compression exponent allows more energy to be stored in the compressed gas than the energy stored if the compression were done via a normal multi-stroke compressor (in which the heat of compression may be lost to the environment.)

A formula for compression exponent greater than 1.05 may be written as:  $PV^n=K$ , where  $P$  is pressure of the compressed gas,  $V$  is volume of the compressed gas,  $n$  is the compression exponent and  $K$  is a constant. For air in an isothermal compression, the compression exponent is 1.05, and for an adiabatic compression the compression exponent is about 1.4. In an embodiment of the present disclosure, as the compression cycle is sufficiently short, the gas in the gas chamber 510 may be compressed to the predetermined pressure at a compression exponent of approximately at least 1.1.

Further, as the first piston 500 reaches towards the TDC of the first cylinder 400, due to the rise profile of the rotating cam 2052, the second arm 2060 continues rotating in the clockwise direction about the pivot point 2062. Accordingly, the first arm 2058 pulls the valve spool 2006 rearward in order to uncover the opening 408 for configuring the open position of the valve arrangement 2000, which is shown in FIGS. 3 and 4.

Now referring to FIG. 3 and FIG. 4, next stages of the operation cycle are shown. Particularly as shown in FIG. 3, the valve arrangement 2000 assumes the open position after completion of the compression stroke. As the valve arrangement 2000 is in the open position, the compressed gas at the predetermined pressure in the first cylinder 400 is communicated to the second cylinder 700 through the gas passageway 2005. The compressed gas is then allowed to expand in the second cylinder 700 causing the second piston 800 and the anvil 900 to move linearly in a downward direction. Further, the anvil 900 extends along a longitudinal axis of the second cylinder 700 into the fastener guide 1010 for striking the fastener 1000. The anvil 900, upon striking the fastener 1000, is capable of driving the fastener 1000 into the workpiece as shown in FIG. 4.

As the compressed gas from the first cylinder 400 is rapidly communicated to the second cylinder 700 through the gas passageway 2005, such rapid communication of the compressed gas from first cylinder 400 to the second cylinder 700 yields a rapid acceleration of the second piston 800 and the anvil 900 in the downward direction. Such rapid acceleration of the second piston 800 and the anvil 900 results in a quick fastener drive stroke with a low reaction force. Additionally, the linear movement of the anvil 900 through the fastener guide 1010 enables in jam clearing of the fastener guide 1010. Such jam clearing removes the fastener fragments or other debris inside the fastener guide 1010 and thereby avoids the need of any manual operation for cleaning the fastener guide 1010. Accordingly, this would automatically make the fastener guide 1010 ready for a next operation cycle of driving the fastener 1000.

After the fastener 1000 is fully driven into the workpiece, the valve arrangement 2000 is configured to assume the

closed position. Due to the fall profile of the rotating cam 2052, the second arm 2060 is free to rotate in the counter clockwise direction about the pivot point 2062. Further, the valve spool return spring 2064 which is in the compressed state during the open position of the valve arrangement 2000, starts expanding and thereby pushes the valve spool 2006 forward in order to cover the opening 408. Accordingly, the valve arrangement 2000 assumes the closed position, as shown in FIG. 5. Further, due to continuous rotation of the motor 300, the first piston 500 is configured to execute the return stroke. During the return stroke, the first piston 500 moves downwardly from the upper end portion 402, i.e., the TDC of the first cylinder 400 towards the lower end portion 404, i.e., the BDC of the first cylinder 400. Further, due to the closed position of the valve arrangement 2000 and the closed position of the check valve 508, a vacuum is created between the TDC of the first cylinder 400 and the first piston 500. More specifically, the vacuum is created between the upper face 502 of the first piston 500 and the cylinder end cap 406.

Further, as shown in FIG. 5, excess gas in the second cylinder 700 may be vented to the atmosphere. The excess gas in the second cylinder 700 may be vented to the atmosphere by means of the elongated groove 2010 of the valve spool 2006 and the vent opening 2012 configured on the valve body 2008. Accordingly, such venting of the excess gas in the second cylinder 700 facilitates reduction of gas pressure above the front face 802 of the second piston 800. Furthermore, in the case that the movement of the first piston 500 is impeded to any extent, such venting releases the pressure on the second piston 800 and the anvil 900, thus providing safety to the user.

Further, as shown in FIG. 6, during the return stroke of the first piston 500, when the first piston 500 reaches a predetermined position, the vacuum created within the first cylinder 400 is sufficient such that the second piston 800 and the anvil 900 may be retracted to their initial positions (as shown in FIG. 1), if the vacuum is communicated to the second cylinder 700. Accordingly, when the first piston 500 reaches the predetermined position in the first cylinder 400, the rocker arm 2056 continues rotating in the clockwise direction about the pivot point 2062 due to the cam rise profile of the rotating cam 2052. Accordingly, the first arm 2058 pulls the valve spool 2006 rearward in order to uncover the opening 408 for configuring the open position of the valve arrangement 2000, which is shown in FIG. 7.

Further, a next stage of the operation cycle is illustrated in FIG. 7. The first arm 2058 pulls the valve spool 2006 rearward and uncovers the opening 408 configured on the cylinder end cap 406 of the first cylinder 400 to configure the open position of the valve arrangement 2000. Thereafter, the vacuum created in the first cylinder 400 is communicated to the second cylinder 700. More specifically, the vacuum created in the first cylinder 400 is filled by the gas communicated from the second cylinder 700, when the valve arrangement 2000 assumes the open position.

Furthermore, as shown in FIG. 8, the vacuum communicated to the second cylinder 700 causes the second piston 800 and the anvil 900 to retract to their initial positions. Further, as the first piston 500 is configured to reach to the BDC of the first cylinder 400, the second piston 800 and the anvil 900 are returned to their initial positions. It would be apparent to those skilled in the art that the second piston 800 and the anvil 900 are retracted to their initial positions without utilizing any drive energy of the fastener driving apparatus 10. Further, a person skilled in the art would appreciate that virtually all energy from the fastener driving apparatus 10 is utilized to drive the fastener 1000 into the workpiece, as the retraction of

15

the second piston **800** and the anvil **900** is performed automatically as the first piston **500** moves towards the BDC of the first cylinder **400** during the return stroke. More specifically, the return of the second piston **800** and the anvil **900** is vacuum actuated, and does not utilize any energy used for driving the fastener **1000**.

Hence, a person skilled in the art would appreciate that the vacuum generated in the first cylinder **400** acts as 'the retracting mechanism' in the fastener driving apparatus **10** of the present disclosure. It would be apparent to those skilled in that art that the anvil **900** of the present disclosure do not require any specific retracting mechanism such as compressing an anvil return spring or a bungee, the fastener driving apparatus **10** of the present disclosure increases the drive speed of the present disclosure. Further, the kinetic energy caused by the axial movement of the second piston **800**, the connector **806** and the anvil **900** is absorbed by the bumper **708**.

As the second piston **800** and the anvil **900** reach to their initial positions, the valve arrangement **2000** is configured to assume the closed position as shown in FIG. 1. When the first piston **500** reaches the BDC of the first cylinder **400**, the second sensor **3004** detects the presence of the first piston **500** at the BDC, and the control circuit **200** receives the detected position from the second sensor **3004**. Further, the control circuit **200** is configured to disconnect the power source **100** from the motor **300** to stop the operation cycle based on feedback from the second sensor **3004**. More specifically, the control circuit **200** disconnects the power from the power source **100** to the motor **300** so that motor **300** stops actuating the linear motion converter **600** for linearly moving the first piston **500** inside the first cylinder **400**. In one embodiment of the present disclosure, the motor **300** may be stopped by means of dynamic braking mechanism. It would be apparent to those ordinary skilled in the art that in this condition, the fastener driving apparatus **10** is in a ready position for performing a next operation cycle of the fastener driving operation. Accordingly, in a single stroke of the first piston **500** the operation cycle of the fastener driving is completed by the fastener driving apparatus **10**. Accordingly, with each triggering (i.e., powering of the switch **302**), one fastener, such as the fastener **1000**, is driven into the workpiece. It would be apparent to those ordinary skilled in the art that in case of continuous driving of fasteners **1000**, the motor **300** may be continued as running in order to execute the successive operation cycles in a continuous manner.

Referring now to FIG. 9, in another embodiment of the present invention, a fastener driving apparatus **20** having a valve arrangement such as a valve arrangement **6000** and a coupling member such as a coupling member **6050**, is shown. The valve arrangement **6000** includes a valve spool **6010**, which has a cam ramp **6012** configured on a rear portion **6014** of the valve spool **6010**. The rear portion **6114** of the valve arrangement **6000** is also operably coupled to a valve spool return spring such as the valve spool return spring **2064**.

The coupling member **6050** includes a cam such as the cam **2052**, a pushrod **6052** and a cam guide such as the cam guide **2066**. The pushrod **6052** is operatively coupled to the cam **2052**. With the rotation of the cam **2052**, the pushrod **6052** executes an upward and downward movement, i.e., towards and away from the shaft **4002**. As shown in FIG. 9, the pushrod **6052** acts against a cam ramp **6012** on the valve spool **6010** to configure the open position or the closed position of the valve arrangement **2000**. The valve spool return spring **2064** also aids in closing the opening **408** when the pushrod **6052** retracts, i.e., goes towards the shaft **4002**.

16

For example, as shown in FIG. 9, due to variable profile of the cam **2052**, when the pushrod **6052** is in contact with the cam ramp **6012** at a point **6016**, the valve arrangement **6000** is in the closed position. Due to the cam rise profile of the cam **2052**, the pushrod **6052** is driven in the upward direction, i.e., away from the shaft **4002**. As the pushrod **6052** acts against the cam ramp **6012** to proceed in the upward direction, a resultant force is applied that pushes the valve spool **6010** in the rearward direction in order to uncover the opening **408** (when the pushrod **6052** is in contact with the cam ramp **6012** at a point **6018**). Due to this, the valve arrangement **6000** assumes the open position and simultaneously the valve spool return spring **2064** also compresses. It would be apparent to those skilled in the art that in an operation cycle, the cam **2052** will rotate by 360 degrees, and the cam **2052** will have a profile having two rises and two falls.

Referring now to FIG. 10, yet another embodiment of the present invention having a valve arrangement such as a valve arrangement **7000** utilized in a fastener driving apparatus **30**, is shown. The fastener driving apparatus **30** does not utilize any coupling member such as the coupling member **2050** operatively coupled between the valve arrangement **7000** and the motor **300**.

The valve arrangement **7000** may include a pneumatic valve **7002** and a valve solenoid **7004**. The valve solenoid **7004** is configured to actuate the pneumatic valve **7002**. The pneumatic valve **7002** includes a valve spool **7006** and a valve body **7008**. The valve spool **7006** is slidably disposed in the valve body **7008**. The valve spool **7006** may include an elongated groove **7010** configured on a central portion thereof. Further, in one embodiment of the present disclosure, the valve spool **7006** may be held in position by means of a spring (not shown) and pressure balance between two o-rings (not shown). The valve body **7008** may further include a vent opening **7012** configured thereon. In the closed position of the valve arrangement **7000**, the vent opening **7012** is configured to receive gas from the elongated groove **7010** and pass the gas to atmosphere.

Further, the valve solenoid **7004** includes an actuating member **7014**, a solenoid return spring **7016**, and a solenoid member **7018**. The actuating member **7014** is configured to actuate the valve spool **7006** to configure one of the closed position and the open position of the valve spool **7006**. The solenoid return spring **7016** is functionally coupled to the actuating member **7014**. The solenoid member **7018** is configured to actuate the actuating member **7014** and the solenoid return spring **7016** such that the valve spool **7006** may assume one of the open position and the closed position. The solenoid member **7018** is electrically coupled to the control circuit **200** that is configured to actuate the solenoid member **7018**. The solenoid member **7018** may be electrically coupled to the control circuit **200** by means of wired, wireless or any other means known in the art. The control circuit **200** may actuate the solenoid member **7018** for configuring the valve arrangement to assume one of the open position and the closed position based on the position of the first piston **500** detected within the first cylinder **400** and timings of start and stop of an operation cycle of the fastener driving apparatus **30**.

More specifically, for configuring the open position of the valve arrangement **7000**, i.e., the open position of the valve spool **7006**, the solenoid member **7018** actuates the actuating member **7014**. Further, the actuating member **7014** moves the valve spool **7006** towards the solenoid member **7018** and unblocks the opening **408** configured on the cylinder end cap **406** of the first cylinder **400**. More specifically, once the valve spool **7006** is cracked open by the solenoid member **7018**, the gas pressure may act on a front face (not shown) of the valve

spool **7006** and moves the valve spool **7006** towards the solenoid member **7018** very fast and snaps the valve spool **7006** to assume the open position. While moving the valve spool **7006** towards the solenoid member **7018**, the actuating member **7014** compresses the solenoid return spring **7016**. Further, the solenoid member **7018** is configured to retain the open position of the valve spool **7006** even when the pressure in the gas chamber **510** drops. Such characteristics of the solenoid member **7018** to retain the open position of the valve spool **7006** even when the pressure in the gas chamber **510** drops, increases efficiency of the valve arrangement **7000** and facilitates a complete driving of the fastener **1000** into the workpiece. Further, the opening force required for configuring the open position of the valve arrangement **7000** is at least 1.5 times of the force required for maintaining the closed position of the valve arrangement **7000**.

Similarly, for configuring the closed position of the valve arrangement **7000**, i.e., the closed position of the valve spool **7006**, the solenoid member **7018** actuates the actuating member **7014** to move towards the second cylinder **700** by means of release of potential energy stored in the solenoid return spring **7016**. Accordingly, the actuating member **7014** moves the valve spool **7006** towards the second cylinder **700**, and thereby blocks the opening **408** configured on the cylinder end cap **406** of the first cylinder **400**.

It would be apparent to those skilled in the art that the valve arrangement **700** may be configured to assume the open position or the closed position based on the signal received from the control circuit **200**. For example, during the compression stroke of the compression stroke of the operation cycle, when the first piston **500** reaches the TDC of the first cylinder **400**, the first sensor **3002** detects the position of the first piston **500** and communicates the detected position of the first piston **500** to the control circuit **200**. Thereafter, the control circuit **200** actuates the solenoid member **7018** of the valve arrangement **7000**. The solenoid member **7018** then actuates the actuating member **7014** for configuring the open position of the valve spool **7006**. Similarly, during the return stroke of the operation cycle, positioning of the first piston **500** at the predetermined position may be detected by the second sensor **3004**. More specifically, the second sensor **3004** is configured to detect the predetermined position of the first piston **500** on the return stroke so as to control the timing when the valve arrangement **7000** should assume the open position. The second sensor **3004** communicates this detected position of the first piston **500** to the control circuit **200**. Further, the control circuit **200** actuates the solenoid member **7018** to configure the open position of the valve arrangement **7000**. Further, as the valve arrangement **7000** assumes the open position, the vacuum is utilized to retract the second piston **800** and the anvil **900** to their initial positions in the second cylinder **700**.

Although in the present embodiment of the present disclosure, the valve arrangement **7000** includes the valve solenoid **7004** for configuring the open position and the closed position of the valve arrangement **7000**, the present disclosure is not limited to this particular arrangement only. In another embodiment of the present disclosure may include a valve arrangement having a pneumatic valve, similar to the pneumatic valve **7002** actuated by a plurality of sensors. Such valve arrangement may be designed by considering various parameters such as pressure drop through the valve arrangement, the opening time of the valve arrangement, and the volume of gas contained in a gas passageway of the valve arrangement.

Various embodiments of the present disclosure offer following advantages. The fastener driving apparatus, such as the fastener driving apparatuses **10**, **10**, **20** and **30**, utilizing

valve arrangements such as valve arrangements **2000**, **6000** and **7000**, respectively. Such fastener driving apparatuses, as described herein, provide retracting mechanisms that precludes consumption of drive energy of the fastener driving apparatuses and facilitates a fastener to be fully driven into a workpiece. Further, the retracting mechanisms of the fastener driving apparatuses of the present disclosure are capable of providing more safety to a user. Furthermore, the retracting mechanisms preclude reduction of drive speed of the fastener driving apparatuses. Moreover, the fastener driving apparatuses of the present disclosure are portable in nature. Further, the fastener driving apparatuses are inexpensive. Furthermore, the fastener driving apparatuses are simple in construction. Still further, the fastener driving apparatuses are capable of minimizing reactionary force and thereby providing more comfort to the user. Additionally, the fastener driving apparatus are capable of driving the fastener into the workpiece in a single stroke.

The foregoing descriptions of specific embodiments of the present disclosure have been presented for purposes of illustration and description. They are not intended to be exhaustive or to limit the present disclosure to the precise forms disclosed, and obviously many modifications and variations are possible in light of the above teaching. The embodiments were chosen and described in order to best explain the principles of the present disclosure and its practical application, and to thereby enable others skilled in the art to best utilize the present disclosure and various embodiments with various modifications as are suited to the particular use contemplated. It is understood that various omissions and substitutions of equivalents are contemplated as circumstances may suggest or render expedient, but such omissions and substitutions are intended to cover the application or implementation without departing from the spirit or scope of the claims of the present disclosure.

What is claimed is:

1. A fastener driving apparatus for driving a fastener into a workpiece, the fastener driving apparatus comprising:
  - a power source;
  - a control circuit electrically coupled to the power source;
  - a motor electrically coupled to the power source and responsive to the control circuit;
  - a first cylinder;
  - a first piston reciprocally movable within the first cylinder to execute a compression stroke and a return stroke in an operation cycle of driving the fastener into the workpiece, the first piston defining a gas chamber within the first cylinder, the gas chamber capable of accommodating gas therein;
  - a linear motion converter driven by the motor and operationally coupled to the first piston for reciprocally moving the first piston within the first cylinder;
  - a second cylinder pneumatically connected to the first cylinder;
  - a second piston reciprocally movable within the second cylinder;
  - an anvil coupled to the second piston, the anvil capable of striking the fastener to drive the fastener into the workpiece;
  - a valve arrangement operationally disposed between the first cylinder and the second cylinder for pneumatically connecting the first cylinder and the second cylinder, the valve arrangement configured to define a gas passageway between the first cylinder and the second cylinder in an open position and blocking the gas passageway in a closed position; and

at least one sensor electrically coupled to the control circuit, the at least one sensor configured to detect at least one position of the operation cycle and communicate the detected position of the operation cycle to the control circuit,

wherein during the compression stroke, the first piston is configured to move towards a top dead center of the first cylinder for compressing the gas in the gas chamber, the valve arrangement assuming the open position for communicating the compressed gas to the second cylinder causing the second piston to move linearly and enabling the anvil to drive the fastener into the workpiece; and

wherein during the return stroke the valve arrangement assumes the closed position and the first piston is configured to move towards a bottom dead center of the first cylinder thereby creating a vacuum in the first cylinder between the top dead center of the first cylinder and the first piston; and

wherein at a predetermined position of the first piston during the return stroke the valve arrangement assumes the open position, thereby communicating the vacuum created in the first cylinder to the second cylinder and causing the second piston and the anvil to retract to initial positions of the second piston and the anvil; and

wherein during the return stroke, based on the at least one detected position by the at least one sensor, the control circuit is configured to disconnect the power source from the motor to stop the operation cycle.

2. The fastener driving apparatus of claim 1, wherein the power source is a rechargeable battery.

3. The fastener driving apparatus of claim 1, wherein the linear motion converter comprises a crankshaft mechanism.

4. The fastener driving apparatus of claim 1, wherein in the open position of the valve arrangement, a compression valve has a flow coefficient greater than one.

5. The fastener driving apparatus of claim 1, wherein during the compression stroke of the first piston the gas in the gas chamber is compressed to the predetermined pressure at a compression exponent greater than 1.05.

6. The fastener driving apparatus of claim 1, wherein the valve arrangement comprises a valve solenoid.

7. The fastener driving apparatus of claim 1, wherein a valve is adapted to allow atmospheric air to flow into the gas chamber after the vacuum has been communicated to from the first cylinder to the second cylinder.

8. The fastener driving apparatus of claim 7 further comprising an actuation member disposed on a body portion of the fastener driving apparatus for actuating the valve to allow the atmospheric air to flow into the gas chamber.

9. The fastener driving apparatus of claim 1, wherein volume of the gas passageway is less than about 15% of volume of the first cylinder.

10. The fastener driving apparatus of claim 1, further comprising a coupling member coupled between the motor and the valve arrangement, the coupling member actuated by the rotation of the motor for actuating the valve arrangement to: assume the open position for communicating the compressed gas to the second cylinder during the compression stroke;

assume the closed position for creating a vacuum in the first cylinder between the top dead center of the first cylinder and the first piston during the return stroke; and assume the open position for communicating the vacuum from the first cylinder to the second cylinder during the return stroke.

11. The fastener driving apparatus of claim 1, wherein the control circuit is further configured to actuate the valve

arrangement to assume the closed position after the vacuum created in the first cylinder is communicated to the second cylinder.

12. The fastener driving apparatus of claim 1, wherein the valve arrangement comprises a pneumatic valve and a valve solenoid for actuating the pneumatic valve, the valve solenoid controlled by the control circuit.

13. The fastener driving apparatus of claim 1, wherein the valve arrangement comprises a vent opening for releasing gas from the second cylinder to atmosphere in the closed position of valve arrangement.

14. A fastener driving apparatus for driving a fastener into a workpiece, the fastener driving apparatus comprising:

a power source;

a control circuit electrically coupled to the power source;

a motor electrically coupled to the power source and responsive to the control circuit;

a first cylinder;

a first piston reciprocally movable within the first cylinder to execute a compression stroke and a return stroke in an operation cycle of driving the fastener into the workpiece, the first piston defining a gas chamber within the first cylinder, the gas chamber capable of accommodating gas therein;

a linear motion converter driven by the motor and operationally coupled to the first piston for reciprocally moving the first piston within the first cylinder;

a second cylinder pneumatically connected to the first cylinder;

a second piston reciprocally movable within the second cylinder;

an anvil coupled to the second piston, the anvil capable of striking the fastener to drive the fastener into the workpiece;

a valve arrangement operationally disposed between the first cylinder and the second cylinder for pneumatically connecting the first cylinder and the second cylinder, the valve arrangement configured to define a gas passageway between the first cylinder and the second cylinder in an open position and blocking the gas passageway in a closed position; and

at least one sensor electrically coupled to the control circuit, the at least one sensor configured to detect at least one position of the operation cycle and communicate the detected position of the operation cycle to the control circuit,

wherein during the compression stroke, the first piston is configured to move towards a top dead center of the first cylinder for compressing the gas in the gas chamber, the valve arrangement assuming the open position for communicating the compressed gas to the second cylinder causing the second piston to move linearly from a first position to a second position and enabling the anvil to move from a first position to a second position to drive the fastener into the workpiece; and

wherein during the return stroke the first piston is configured to move towards a bottom dead center of the first cylinder, thereby creating a vacuum in the gas chamber at the top of the first cylinder,

wherein said valve arrangement assumes an open position during at least a portion of the return stroke of the first piston, thereby communicating said vacuum through said valve arrangement to the second cylinder, which vacuum causes the second piston to move linearly from said second position to said first position and the anvil to move from said second position to said first position;

21

and wherein during the return stroke, based on the at least one detected position by the at least one sensor, the control circuit is configured to disconnect the power source from the motor to stop the operation cycle.

15. The fastener driving apparatus of claim 1, wherein the second cylinder further comprises a magnet disposed on a top plate thereof, and the anvil comprises a ferrous material.

16. The fastener driving apparatus of claim 14, wherein the second cylinder further comprises a magnet disposed on a top plate thereof, and the anvil comprises a ferrous material.

17. A fastener driving apparatus for driving a fastener into a workpiece, the fastener driving apparatus comprising:

a power source;

a control circuit electrically coupled to the power source;

a motor electrically coupled to the power source and responsive to the control circuit;

a first cylinder;

a first piston reciprocally movable within the first cylinder to execute a compression stroke and a return stroke in an operation cycle of driving the fastener into the work-

piece, the first piston defining a gas chamber within the first cylinder, the gas chamber capable of accommodating gas therein;

a linear motion converter driven by the motor and operationally coupled to the first piston for reciprocally moving the first piston within the first cylinder;

a second cylinder pneumatically connected to the first cylinder;

a second piston reciprocally movable within the second cylinder;

an anvil coupled to the second piston, the anvil capable of striking the fastener to drive the fastener into the workpiece;

a valve arrangement operationally disposed between the first cylinder and the second cylinder for pneumatically

22

connecting the first cylinder and the second cylinder, the valve arrangement configured to define a gas passageway between the first cylinder and the second cylinder in an open position and blocking the gas passageway in a closed position; and

at least one sensor electrically coupled to the control circuit, the at least one sensor configured to detect at least one position of the operation cycle and communicate the detected position of the operation cycle to the control circuit,

wherein during the compression stroke, the first piston is configured to move towards a top dead center of the first cylinder for compressing the gas in the gas chamber, the valve arrangement assuming the open position for communicating the compressed gas to the second cylinder causing the second piston to move linearly from a first position to a second position and enabling the anvil to move from a first position to a second position to drive the fastener into the workpiece; and

wherein during the return stroke the first piston is configured to move towards a bottom dead center of the first cylinder, thereby creating a vacuum in the gas chamber at the top of the first cylinder,

wherein said valve arrangement assumes an open position during at least a portion of the return stroke of the first piston, thereby communicating said vacuum through said valve arrangement to the second cylinder, which vacuum causes the second piston to move linearly from said second position to said first position and the anvil to move from said second position to said first position; and

wherein based on the at least one detected position by the at least one sensor, the control circuit is configured to stop the operation cycle.

\* \* \* \* \*