

(19) World Intellectual Property Organization
International Bureau



(43) International Publication Date
25 November 2004 (25.11.2004)

PCT

(10) International Publication Number
WO 2004/101826 A2

(51) International Patent Classification⁷: C12Q 1/68, 1/02

(21) International Application Number:
PCT/US2004/007181

(22) International Filing Date: 8 March 2004 (08.03.2004)

(25) Filing Language: English

(26) Publication Language: English

(30) Priority Data:
10/387,345 10 March 2003 (10.03.2003) US

(71) Applicants (for all designated States except US):
PRINCETON UNIVERSITY [US/US]; Office of Technology Licensing and Intellectual Property, Fourth Floor, New South Building, Post Office Box 36, Princeton, NJ 08544-0036 (US). **UNIVERSITY TECHNOLOGIES INTERNATIONAL, INC.** [CA/CA]; Suite 130, 3553-31 Street, NW, Calgary, Alberta T2L 2K7 (CA).

(72) Inventors; and

(75) Inventors/Applicants (for US only): **BASSLER, Bonnie,**

L. [US/US]; 39 Pine Street, Princeton, NJ 08542 (US). **SURETTE, Michael, G.** [CA/CA]; 58 Hawkwood Boulevard, Calgary, Alberta T2W 4W1 (CA).

(74) Agent: **McKAY, Diane, Dunn;** Mathews, Collins, Shepherd & McKay PA, 100 Thanet Circle, Suite 306, Princeton, NJ 08540-3674 (US).

(81) Designated States (unless otherwise indicated, for every kind of national protection available): AE, AG, AL, AM, AT, AU, AZ, BA, BB, BG, BR, BW, BY, BZ, CA, CH, CN, CO, CR, CU, CZ, DE, DK, DM, DZ, EC, EE, EG, ES, FI, GB, GD, GE, GH, GM, HR, HU, ID, IL, IN, IS, JP, KE, KG, KP, KR, KZ, LC, LK, LR, LS, LT, LU, LV, MA, MD, MG, MK, MN, MW, MX, MZ, NA, NI, NO, NZ, OM, PG, PH, PL, PT, RO, RU, SC, SD, SE, SG, SK, SL, SY, TJ, TM, TN, TR, TT, TZ, UA, UG, US, UZ, VC, VN, YU, ZA, ZM, ZW.

(84) Designated States (unless otherwise indicated, for every kind of regional protection available): ARIPO (BW, GH, GM, KE, LS, MW, MZ, SD, SL, SZ, TZ, UG, ZM, ZW), Eurasian (AM, AZ, BY, KG, KZ, MD, RU, TJ, TM), European (AT, BE, BG, CH, CY, CZ, DE, DK, EE, ES, FI, FR,

[Continued on next page]

(54) Title: COMPOSITIONS AND METHODS FOR REGULATING BACTERIAL PATHOGENESIS

Hybrid quorum sensing circuit of *Vibrio harveyi*

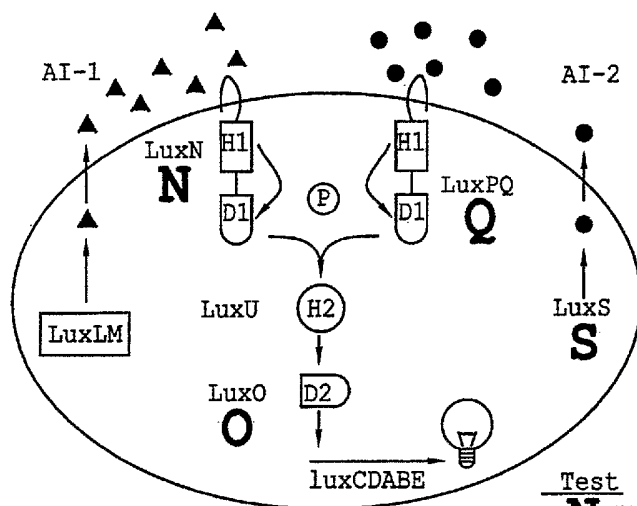

	<u>Test</u>	<u>Control</u>
N	BB170	Q BB886
SN	Double	O JAF78

(57) Abstract: The production of a purified extracellular bacterial signal called autoinducer-2 is regulated by changes in environmental conditions associated with a shift from a free-living existence to a colonizing or pathogenic existence in a host organism. Autoinducer 2 LuxQ luminescence genes, and is believed also to stimulate a variety of pathogenesis related genes in the bacterial species that produce it. A new class of bacterial genes is involved in the biosynthesis of autoinducer-2.

WO 2004/101826 A2



GB, GR, HU, IE, IT, LU, MC, NL, PL, PT, RO, SE, SI, SK,
TR), OAPI (BF, BJ, CF, CG, CI, CM, GA, GN, GQ, GW,
ML, MR, NE, SN, TD, TG).

For two-letter codes and other abbreviations, refer to the "Guidance Notes on Codes and Abbreviations" appearing at the beginning of each regular issue of the PCT Gazette.

Published:

— *without international search report and to be republished upon receipt of that report*

COMPOSITIONS AND METHODS FOR REGULATING BACTERIAL PATHOGENESIS

STATEMENT AS TO FEDERALLY-SPONSORED RESEARCH

[0001] Pursuant to 35 U.S.C. §202(c), the U.S. Government has certain rights in the invention described herein, which was made in part with funds from the National Science Foundation, Grant No. MCB-9506033.

FIELD OF THE INVENTION

[0002] This invention relates to the field of bacterial diseases of humans and other mammals. In particular, the invention provides novel genes and signaling factors involved in inducing pathogenesis in certain bacteria, and methods for controlling such pathogenesis through manipulation of those factors and genes.

BACKGROUND OF THE INVENTION

[0003] Several publications are referenced in this application to more fully describe the state of the art to which this invention pertains.

[0004] The control of gene expression in response to cell density, or quorum sensing, was first described in the marine luminous bacteria *Vibrio fischeri* and *Vibrio harveyi*. This phenomenon has recently become recognized as a general mechanism for gene regulation in many Gram-negative bacteria. Quorum sensing bacteria synthesize, release, and respond to specific acyl-homoserine lactone signaling compounds called autoinducers to control gene expression as a function of cell density. In all acyl-homoserine lactone quorum sensing systems described to date, except that of *V. harveyi*, the autoinducer synthase is encoded by a gene homologous to luxI of *V. fischeri*, and response to the autoinducer is mediated by a transcriptional activator protein encoded by a gene homologous to luxR of *V. fischeri* (Bassler and Silverman, in Two component Signal Transduction, Hoch *et al.*, eds, Am. Soc. Microbiol. Washington D.C., pp 431-435, 1995). In contrast, *V. harveyi* has two independent density sensing systems (called Signaling Systems 1 and 2), and each is composed of a sensor-autoinducer pair. *V. harveyi* Signaling System 1 is composed of Sensor 1 and autoinducer 1 (AI-1), and this autoinducer is N-(3-hydroxybutanoyl)-L-homoserine lactone (see Bassler *et al.*, Mol. Microbiol. 9: 773-786, 1993). *V. harveyi* Signaling System 2 is composed of Sensor 2 and autoinducer 2 (AI-2) (Bassler *et al.*, Mol. Microbiol. 13: 273-286, 1994). The structure of AI-2 heretofore has not been determined, nor have the gene(s) involved in biosynthesis of AI-2 been identified. Signaling System 1 is a highly specific system proposed to be used for intra-species communication and Signaling System 2 appears to be less species-selective, and is hypothesized to be for inter-species communication (Bassler *et al.*, J. Bacteriol. 179: 4043-4045, 1997).

[0005] Reporter strains of *V. harveyi* have been constructed that can produce light exclusively in response to AI-1 or to AI-2 (Bassler *et al.*, 1993, *supra*; Bassler *et al.*, 1994, *supra*). *V. harveyi*

reporter strains have been used to demonstrate that a few species of bacteria produce stimulatory substances that mimic the action of AI-2 (Bassler *et al.*, 1997, *supra*).

[0006] Quorum sensing in *V. harveyi*, mediated by Signaling Systems 1 and 2, triggers the organisms to bioluminesce at a certain cell density. These same signaling systems, particularly Signaling System 2, are believed to trigger other physiological changes in *V. harveyi* and other bacteria possessing the same signaling system. Thus, it would be an advance in the art to identify and characterize the signaling factor autoinducer-2 and the genes encoding the proteins required for its production. Such an advance would provide a means to identify a novel class of compounds useful for controlling mammalian enteric or pathogenic bacteria.

SUMMARY OF THE INVENTION

[0007] In accordance with the present invention, it has now been discovered that a variety of bacterial species, some of them mammalian pathogens, secrete an organic signaling compound that stimulates the expression of luminescence in the *V. harveyi* Signaling System 2 bioassay. The compound secreted by these organisms mimics *V. harveyi* AI-2 in its physical and functional features. The production in bacteria of this novel signaling compound is regulated by changes in environmental conditions associated with a shift from a free-living existence to a colonizing or pathogenic existence in a host organism. Thus, in addition to stimulating luminescence genes (specifically luxCDABE) in *V. harveyi*, the signaling compound is expected to stimulate a variety of pathogenesis related genes in the bacterial species that produce it. A highly purified form of the signaling compound is provided in the present invention. Also provided is a new class of bacterial genes involved in the biosynthesis of the signaling compound.

[0008] According to one aspect, the present invention provides an isolated bacterial extracellular signaling factor comprising at least one compound that is polar and uncharged, and having an approximate molecular weight of less than 1,000 kDa, wherein said factor interacts with LuxQ protein thereby inducing expression of a *Vibrio harveyi* operon comprising luminescence genes luxCDABE. In a preferred embodiment, the factor possesses a specific activity wherein about 0.1 to 1.0 mg of a preparation of the factor stimulates about a 1,000-fold increase in luminescence, as measured in a bioassay using a *V. harveyi* Sensor 2+ reporter strain. In a particularly preferred embodiment, the factor is purified in such a way that it possesses a specific activity wherein about 1 to 10 µg of a preparation of the factor stimulates about a 1,000-fold increase in luminescence, as measured in a bioassay using a *V. harveyi* Sensor 2+ reporter strain.

[0009] The signaling factor of the invention is produced by a variety of bacteria, including but not limited to: *Vibrio harveyi*, *Vibrio cholerae*, *Vibrio parahaemolyticus*, *Vibrio alginolyticus*, *Pseudomonas phosphoreum*, *Yersinia enterocolitica*, *Escherichia coli*, *Salmonella typhimurium*, *Haemophilus influenzae*, *Helicobacter pylori*, *Bacillus subtilis*, *Borrelia burgdorferi*, *Neisseria meningitidis*, *Neisseria gonorrhoeae*, *Yersinia pestis*, *Campylobacter jejuni*, *Deinococcus radiodurans*,

Mycobacterium tuberculosis, *Enterococcus faecalis*, *Streptococcus pneumoniae*, *Streptococcus pyogenes* and *Staphylococcus aureus*.

[0010] In another aspect, the invention provides an isolated bacterial signaling factor having the formula:

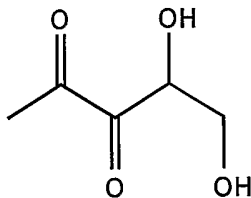

[0011] In yet another aspect, the invention provides a method for detecting an autoinducer compound in a sample by contacting the sample with a bacterial cell, or extract thereof, comprising biosynthetic pathways that produce a detectable amount of light in response to an exogenous autoinducer, the bacterial cell having at least two distinct alterations in gene loci that participate in autoinducer pathways, wherein a first alteration in a gene locus comprises an alteration that inhibits production of a first autoinducer and wherein a second alteration in a gene locus comprises an alteration that inhibits detection of a second autoinducer and measuring light produced by the bacterial cell, or extract thereof.

[0012] In another aspect, the invention provides a bacterial cell having at least two distinct alterations in gene loci that participate in autoinducer pathways, wherein a first alteration inhibits production of a first autoinducer and wherein a second alteration inhibits detection of a second autoinducer and wherein the cell is bioluminescent when contacted with an autoinducer.

[0013] In another aspect, the invention provides a method for identifying an autoinducer analog that regulates the activity of an autoinducer by contacting a bacterial cell, or extract thereof, comprising biosynthetic pathways that produce light in response to an autoinducer with an autoinducer analog and comparing the amount of light produced by the bacterial cell, or extract thereof, in the presence of an autoinducer with the amount produced in the presence of the autoinducer analog, wherein a change in the production of light indicates an autoinducer analog that regulates the activity of an autoinducer.

[0014] Another embodiment of the invention is a method for identifying a compound that modulates the response to a first autoinducer that is not an acyl-homoserine lactone, comprising obtaining a cell that produces a detectable signal in response to the first autoinducer, measuring the response of the cell to the first autoinducer in the presence and absence of a test compound, and comparing the responses obtained in the presence and the absence of the test compound to determine whether the test compound modulates the response to the first autoinducer. In one aspect of this embodiment, the cell has a first genetic alteration that inhibits production of the first autoinducer. For example, the first genetic alteration may be introduced in the cell by genetic engineering. The first autoinducer may be the autoinducer-2 produced by *Vibrio harveyi*. In some aspects of the invention,

the first genetic alteration inhibits production of a pentanedione. For example, in some aspects of the invention, the first genetic alteration may inhibit the production of 4,5-dihydroxy-2,3-pentanedione. In some aspects of the invention, the cell belongs to a species selected from the group consisting of *S. typhimurium* and *E. coli*. In other aspects of the invention, the cell belongs to a species selected from the group consisting of *Haemophilus influenzae*, *Helicobacter pylori*, *Bacillus subtilis*, *Borrelia burgdorferi* and *Vibrio cholerae*. In further aspects of the invention, the cell is a *Vibrio harveyi* cell. In some aspects of the invention, the first genetic alteration is in the *luxS* gene of *Vibrio harveyi*. In other aspects of the invention, the first genetic alteration is in a nucleotide sequence having at least 50% sequence homology or nucleotide sequence identity to the *luxS* gene of *V. harveyi*. In some aspects of the invention, the first genetic alteration is in a nucleotide sequence having at least 60% sequence homology or nucleotide sequence identity to the *luxS* gene of *V. harveyi*. In other aspects of the invention, the first genetic alteration is in a nucleotide sequence having at least 80% sequence homology or nucleotide identity to the *luxS* gene of *V. harveyi*. In some embodiments, nucleotide sequence identity may be measured using BLASTN version 2.0 with the default parameters or tBLASTX with the default parameters. (Altschul, S.F. et al. Gapped BLAST and PSI-BLAST: A New Generation of Protein Database Search Programs, *Nucleic Acid Res.* 25: 3389-3402 (1997)). In still further aspects of the invention, the first genetic alteration is in a gene encoding a protein having at least 57% sequence homology to the LuxS protein of *V. harveyi*. In other aspects of the invention, the first genetic alteration is in a gene encoding a protein having at least 85% sequence homology to the LuxS protein of *V. harveyi*. In further aspects of the invention, the first genetic alteration is in a gene encoding a protein having at least 32% sequence identity to the LuxS protein of *V. harveyi*. In additional aspects of the invention, the first genetic alteration is in a gene encoding a protein having at least 45% sequence identity to the LuxS protein of *V. harveyi*. In yet other aspects of the invention, the first genetic alteration is in a gene encoding a protein having at least 74% sequence identity to the LuxS protein of *V. harveyi*. In additional aspects of the invention, the first genetic alteration is in a gene encoding a protein having at least 80% sequence identity to the LuxS protein of *V. harveyi*. In some embodiments, levels of protein homology or sequence identity may be determined using the FASTA version 3.0t78 algorithm with the default parameters. Alternatively, protein identity or homology may be identified using BLASTP with the default parameters, BLASTX with the default parameters, TBLASTN with the default parameters, or tBLASTX with the default parameters. (Altschul, S.F. et al. Gapped BLAST and PSI-BLAST: A New Generation of Protein Database Search Programs, *Nucleic Acid Res.* 25: 3389-3402 (1997)). In some aspects of the invention, the cell has a second genetic alteration that inhibits detection of a second autoinducer. For example, the second autoinducer may be an acyl-homoserine lactone. In some aspects of the invention, the second autoinducer is N-(3-hydroxyacyl)-L-homoserine lactone and the acyl group comprises 4-12 carbon atoms. For example, the acyl group may comprises four carbon atoms. In some aspects of the invention, the response of the cell is bioluminescence.

[0015] Another embodiment of the invention is a method for identifying a compound that modulates the response to a non-acyl-homoserine lactone autoinducer, comprising obtaining an isolated and purified bacterial strain comprising a first genetic alteration that inhibits production of a first autoinducer that is not an acyl-homoserine lactone, and a second genetic alteration that inhibits detection of a second autoinducer that is an acyl-homoserine lactone, measuring the response of the bacterial strain to the first autoinducer in the presence and absence of a test compound, and comparing the responses obtained in the presence and the absence of the test compound to determine whether the compound modulates the response to the second autoinducer. In some aspects of the invention, the bacterial strain is a strain of *Vibrio harveyi*. In some aspects of the invention, the response is bioluminescence. In some aspects of the invention the first alteration is in the *luxS* gene. In some aspects of the invention, the second alteration is in the *luxN* gene. In some aspects of the invention, the first alteration inhibits production of the autoinducer-2 produced by *Vibrio harveyi*. In some aspects of the invention, the bacterial strain belongs to a species other than *Vibrio harveyi*.

[0016] For example, the bacterial strain may belong to a species selected from the group consisting of *S. typhimurium* and *E. coli*. In some aspects of the invention, the bacterial strain belongs to a species selected from the group consisting of *Haemophilus influenzae*, *Helicobacter pylori*, *Bacillus subtilis*, *Borrelia burgdorferi* and *Vibrio cholerae*. In some aspects of the invention, the second autoinducer is N-(3-hydroxyacyl)-L-homoserine lactone and the acyl group comprises 4-12 carbon atoms. In some aspects of the invention, the first alteration inhibits production of the autoinducer-2 produced by *Vibrio harveyi*. In some aspects of the invention the first and second alterations have been introduced into the strain by genetic engineering. In some aspects of the invention, the first alteration inhibits production of a pentanedione. In some aspects of the invention, the pentanedione is 4,5-dihydroxy-2,3-pentanedione. In some aspects of the invention, the second autoinducer is N-(3-hydroxybutanoyl)-L-homoserine lactone. In some aspects of the invention, the first alteration is in a nucleotide sequence having at least 50% sequence homology or nucleotide sequence identity to the *luxS* gene of *V. harveyi*. In some aspects of the invention. In some aspects of the invention, the first alteration is in a nucleotide sequence having at least 60% sequence homology or nucleotide sequence identity to the *luxS* gene of *V. harveyi*. In some aspects of the invention, the first alteration is in a nucleotide sequence having at least 80% sequence homology or nucleotide sequence identity to the *luxS* gene of *V. harveyi*. In some embodiments, nucleotide sequence identity may be measured using BLASTN version 2.0 with the default parameters or tBLASTX with the default parameters. (Altschul, S.F. et al. Gapped BLAST and PSI-BLAST: A New Generation of Protein Database Search Programs, *Nucleic Acid Res.* 25: 3389-3402 (1997)). In some aspects of the invention, the first alteration is in a gene encoding a protein having at least 57% sequence homology to the LuxS protein of *V. harveyi*. the first alteration is in a gene encoding a protein having at least 85% sequence homology to the LuxS protein of *V. harveyi*. In some embodiments, levels of protein homology or sequence identity may be

determined using the FASTA version 3.0t78 algorithm with the default parameters. Alternatively, protein identity or homology may be identified using BLASTP with the default parameters, BLASTX with the default parameters, TBLASTN with the default parameters, or tBLASTX with the default parameters. (Altschul, S.F. et al. Gapped BLAST and PSI-BLAST: A New Generation of Protein Database Search Programs, *Nucleic Acid Res.* 25: 3389-3402 (1997)). In some aspects of the invention, the first alteration is in a gene encoding a protein having at least 32% sequence identity to the LuxS protein of *V. harveyi*. In some aspects of the invention, the first alteration is in a gene encoding a protein having at least 45% sequence identity to the LuxS protein of *V. harveyi*. In some aspects of the invention, the first alteration is in a gene encoding a protein having at least 74% sequence identity to the LuxS protein of *V. harveyi*. In some aspects of the invention, the first alteration is in a gene encoding a protein having at least 80% sequence identity to the LuxS protein of *V. harveyi*.

[0017] In another aspect, the invention provides a method for producing autoinducer-2 by contacting S-adenosylhomo-cysteine (SAH) with a LuxS protein under conditions and for such time as to promote the conversion of S-adenosylhomo-cysteine to autoinducer-2.

[0018] In another aspect, the invention provides a method for producing autoinducer-2 by contacting S-ribosylhomo-cysteine (SRH) with a LuxS protein under conditions and for such time as to promote the conversion of S-ribosylhomocysteine to autoinducer-2.

[0019] In another aspect, the invention provides A method for producing autoinducer-2 by contacting S-adenosylhomo-cysteine (SAH) with a 5'-methylthioadenosine/S-adenosylhomo-cysteine nucleosidase protein under conditions and for such time as to promote the conversion of S-adenosylhomocysteine to S-ribosylhomocysteine; contacting the above-described S-ribosylhomocysteine with a LuxS protein under conditions and for such time as to promote the conversion of S-ribosylhomocysteine to autoinducer-2.

[0020] In another aspect, the invention provides a method for detecting an autoinducer-associated bacterial biomarker by contacting at least one bacterial cell with an autoinducer compound under conditions and for such time as to promote induction of a bacterial biomarker and detecting the bacterial biomarker.

[0021] In another aspect, the invention provides a method for detecting a target compound that binds to a LuxP protein by contacting the LuxP protein with the target compound and detecting binding of the compound to LuxP.

[0022] In another aspect, the invention provides a method for regulating bacterial biofilm formation comprising contacting a bacterium capable of biofilm formation with a compound capable of regulating biofilm formation, wherein the compound regulates autoinducer-2 activity.

[0023] According to another aspect of the invention, a method is provided for purifying the aforementioned bacterial extracellular signaling factor. The method comprises the steps of: (a) growing, in a culture medium, bacterial cells that produce the signaling compound; (b) separating the bacterial

cells from the culture medium; (c) incubating the bacterial cells in a solution having high osmolarity, under conditions that permit production and secretion of the signaling compound from the bacterial cells; (d) separating the bacterial cells from the high osmolarity solution; and (e) purifying the factor from the high osmolarity solution. The method may further comprise: (f) separating polar factors from non-polar factors in an evaporated sample of the high osmolarity solution; and (g) subjecting the polar factors to reverse-phase High Performance Liquid Chromatography. In a preferred embodiment, the high osmolarity solution comprises at least 0.4 M monovalent salt, most preferably 0.4 - 0.5 M NaCl.

[0024] In another preferred embodiment, the method further comprises growing the bacterial cells in a culture medium containing a carbohydrate selected from the group consisting of glucose, fructose, mannose, glucitol, glucosamine, galactose and arabinose.

[0025] According to another aspect of the invention, an isolated nucleic acid is provided, which encodes a protein necessary for biosynthesis of a bacterial extracellular signaling factor that induces expression of a *Vibrio harveyi* *LuxQ* luminescence gene. The nucleic acid may be isolated from a wide variety of bacteria, including but not limited to: *Vibrio harveyi*, *Vibrio cholera*, *Salmonella typhimurium*, *Escherichia coli*, *Haemophilus influenzae*, *Helicobacter pylori*, *Bacillus subtilis* and *Borrelia burgdorferi*.

[0026] The aforementioned nucleic acid encodes a protein having between about 150 and 200 amino acid residues. Preferably, the encoded protein comprises an amino acid sequence substantially the same as a sequence selected from the group consisting of any of SEQ ID NOS:10-17, or a consensus sequence derived from a comparison of two or more of SEQ ID NOS: 10-17. The nucleic acid preferably has a sequence substantially the same as a sequence selected from the group consisting of any of SEQ ID NOS:1 - 9, or a consensus sequence derived from a comparison of two or more of SEQ ID NOS: 1-9.

[0027] Recombinant DNAs comprising the aforementioned nucleic acids are also provided in accordance with the present invention, as well as proteins produced by expression of any of the nucleic acids.

[0028] Additional features and advantages of the present invention will be better understood by reference to the drawings, detailed description and examples that follow.

BRIEF DESCRIPTION OF THE DRAWINGS

[0029] Figure 1. Signaling substance from *E. coli* AB1157 and *S. typhimurium* LT2 cell-free culture fluids that induces luminescence in *V. harveyi*. The responses of *V. harveyi* reporter strains BB170 (Sensor 1⁻, Sensor 2⁺) (Fig. 1A), and BB886 (Sensor 1⁺, Sensor 2⁻) (Fig. 1B) to signaling substances present in cell-free culture fluids from *E. coli*, *S. typhimurium* and *V. harveyi* strains are shown. A bright culture of each reporter strain was diluted 1:5000 into fresh medium, and the light production per cell was then measured during the growth of the diluted culture. Cell-free culture fluids or sterile growth medium were added at a final concentration of 10% (v/v) at the start of the experiment. The data for the 5 hour time point are shown and are presented as the percent of the activity obtained

when *V. harveyi* cell-free spent culture fluids are added. Abbreviations used for the different strains are: *V.h.*; *Vibrio harveyi*, *S.t.*; *Salmonella typhimurium*, and *E.c.*; *Escherichia coli*.

[0030] Figure 2. Active secretion of the signaling compound by viable *E. coli* and *S. typhimurium*. The response of the *V. harveyi* reporter strain BB170 (Sensor 1⁻, Sensor 2⁺) to a signaling substance produced and secreted by *E. coli* AB1157 and *S. typhimurium* LT2 but not *E. coli* DH5 is shown. *V. harveyi* reporter strain BB170 was diluted 1:5000 in AB medium and light output per cell was monitored during growth. At the start of the experiment, either 1×10^6 *E. coli* AB1157, *S. typhimurium* LT2 or *E. coli* DH5 washed and resuspended viable cells (left-hand, white bars) or UV-killed cells (right-hand, black bars) was added. The data are presented as the fold-activation above the endogenous level of luminescence expressed by *V. harveyi* BB170 at the 5 hour time point. Abbreviations used for the different strains are: *S.t.*; *Salmonella typhimurium*, and *E.c.*; *Escherichia coli*.

[0031] Figure 3. Effect of glucose depletion on the production and degradation of the signaling activity by *S. typhimurium* LT2. *S. typhimurium* LT2 was grown in LB medium containing either 0.1% glucose (Fig. 3A) or 0.5% glucose (Fig. 3B). At the specified times cell-free culture fluids were prepared and assayed for signaling activity in the luminescence stimulation assay (Bars), and the concentration of glucose remaining (circles). The cell number was determined at each time by diluting and plating the *S. typhimurium* LT2 on LB medium and counting colonies the next day (squares). The signaling activity is presented as the percent of the activity obtained when *V. harveyi* cell-free spent culture fluids are added. These data correspond to the 5 h time point in the luminescence stimulation assay. The glucose concentration is shown as % glucose remaining. Cell number is cells/ml $\times 10^9$. The symbol \ indicates that the time axis is not drawn to scale after 8 h.

[0032] Figure 4. Response curve of *V. harveyi* to AI-2 produced by *V. harveyi* and *S. typhimurium*. The *V. harveyi* reporter strain BB170 (Sensor 1⁻, Sensor 2⁺) was tested for its response to the addition of exogenous AI-2 made by *V. harveyi* strain BB152 (AI-1⁻, AI-2⁺) and to that made by *S. typhimurium* LT2. A bright culture of the reporter strain was diluted 1:5000 and either 10% (v/v) growth medium (closed circles), cell-free culture fluid from *V. harveyi* BB152 grown overnight in AB (open circles), or cell-free culture fluid from *S. typhimurium* LT2 grown for 6 h on LB + 0.5% glucose (closed squares) was added at the start of the experiment. RLU denotes relative light units and is defined as (counts min⁻¹ $\times 10^3$)/(colony-forming units ml⁻¹).

[0033] Figure 5. Conditions affecting autoinducer production in *S. typhimurium*. *S. typhimurium* LT2 was subjected to a variety of treatments after which cell-free culture fluids or osmotic shock fluids were prepared. These preparations were added to a diluted culture of the *V. harveyi* AI-2 reporter strain BB170 at 10% (v/v) and light output was measured thereafter. Fold activation is the level of light produced by the reporter following addition of the specified *S. typhimurium* preparation divided by the light output of the reporter when growth medium alone was added. The bars in Fig. 5A represent cell-free fluids prepared from *S. typhimurium* after the following treatments: LB 6h; 6 h growth in LB

at 30°C, LB+Glc 6h; 6 h growth in LB + 0.5 % glucose at 30°C, LB+Glc 24h; 24 h growth in LB + 0.5% glucose at 30°C. In all the experiments presented in Fig. 5B, the *S. typhimurium* were pre-grown at 30°C for 6 h in LB containing 0.5% glucose, then pelleted and resuspended for 2 h under the following conditions: LB; in LB at 30°C, LB+Glc; in LB + 0.5% glucose at 30°C, LB pH 5; in LB at pH 5.0 at 30°C, 0.4 M NaCl; in 0.4 M NaCl at 30°C, 0.1 M NaCl; in 0.1 M NaCl at 30°C, and Heat Shock 43°; in LB + 0.5% glucose at 43°C. After these two hour treatments, cell-free fluids were prepared from each sample and assayed.

[0034] Figure 6. *S. typhimurium* signaling activity in limiting and non-limiting concentrations of glucose. *S. typhimurium* LT2 was grown in LB in the presence of limiting (0.1%) and non-limiting (1.0%) concentrations of glucose. The activity present in the cell-free culture fluids (black bars) was assayed at the times indicated and normalized to that produced by 1×10^9 cells. The increase in signaling activity measured in the 0.4 M NaCl osmotic shock fluids prepared from the same cells is shown as the white bars on top of the black bars. These data are also normalized for 1×10^9 cells. The signaling activity for limiting glucose is shown in Figs. 6A, 6C, and 6E, and that for non-limiting glucose is shown in Figs. 6B, 6D, and 6F. Figs. 6A and 6B also show the percent glucose remaining (triangles), Figs. 6C and 6D show the cell number (squares), and Panels E and F show the pH (circles) at each time point.

[0035] Figure 7. Effects of glucose and pH on signal production by *S. typhimurium*. The quorum sensing signal released by *S. typhimurium* LT2 was measured when the cells were grown in LB medium containing 0.5% glucose at pH 7.2 (Fig. 7A, bars), and when the cells were grown in LB at pH 5.0 without an added carbon source (Fig. 7B, bars). The level of signal present in cell free culture fluids (black bars) and in 0.4 M NaCl osmotic shock fluids was measured (white bars on top of black bars) at the time points indicated. In each panel, the circles represent the pH of the medium, and the squares show the cell number at the different time points.

[0036] Figure 8. High osmolarity induces signal release and low osmolarity induces signal degradation in *S. typhimurium* LT2. The quorum sensing signal released by *S. typhimurium* LT2 resuspended in 0.4 M NaCl and in 0.1 M NaCl was measured in the presence and absence of protein synthesis. *S. typhimurium* LT2 was pre-grown in LB containing 0.5% glucose for 6 h. The cells were harvested and resuspended in 0.4 M NaCl (Fig. 8A) or 0.1 M NaCl (Fig. 8B) in the presence or absence of 30 g/ml Cm for the time periods indicated. In each panel, the open symbols represent the activity measured in the absence of Cm and the closed symbols represent the activity measured in the presence of Cm.

[0037] Figure 9. The *luxS* and *ygaG* genes from *V. harveyi* and *E. coli* MG1655. Fig. 9A shows a restriction map of the *V. harveyi luxS_{V,h}* chromosomal region which was defined by Tn5 insertion. The sites of Tn5 insertions that disrupted the AI-2 production function and one control Tn5 insertion outside of the *luxS_{V,h}* locus are shown (triangles). Fig. 9B depicts the *ygaG* region in the *E. coli* MG1655

chromosome. This ORF is flanked by the *emrB* and *gshA* genes. The direction of transcription of each gene is indicated by the horizontal arrows. The corresponding position of the MudJ insertion that eliminated AI-2 production in *S. typhimurium* LT2 is shown by a vertical arrow. H, R, P, and B denote *HindIII*, *EcoRI*, *PstI* and *BamHI* restriction sites respectively.

[0038] Figure 10. Autoinducer production phenotypes of *V. harveyi* and *S. typhimurium* strains. Cell-free culture fluids from *V. harveyi* and *S. typhimurium* strains were prepared and tested for AI-2 activity in the *V. harveyi* BB170 bioassay. Fig. 10A: AI-2 production phenotypes of the wild type *V. harveyi* strain MM28 which contains a Tn5 insertion outside of *luxS_{V.h.}* (denoted WT) and the *luxS_{V.h.}::Tn5* mutant strain MM30 (denoted *luxS^S*). Fig. 10B: AI-2 production phenotypes of wild type *S. typhimurium* LT2 (denoted WT) and the *ygaG::MudJ* insertion mutant strain CS132 (denoted *ygaG^G*). Activity is reported as fold-induction of luminescence expression of the *V. harveyi* BB170 reporter strain over that when sterile medium was added.

[0039] Figure 11. Complementation of AI-2 production in *S. typhimurium* CS132 and *E. coli* DH5. Cell-free culture fluids from *E. coli* and *S. typhimurium* strains were tested for AI-2 activity in the bioassay. The activity present in these fluids was compared to that produced by wild type *V. harveyi* BB120. In the figure, the level of BB120 activity was normalized to 100%. Fig. 11A: AI-2 activity in cell-free fluids from wild type *V. harveyi* BB120, *E. coli* O157:H7, and *S. typhimurium* LT2. Fig. 11B: Complementation of *S. typhimurium* CS132 (*ygaG::MudJ*) and Fig. 11C: Complementation of *E. coli* DH5. In Panel B and C, the *in trans* AI-2 production genes are the following: vector control (denoted: none), *E. coli* O157:H7 *ygaG*; and *V. harveyi* BB120 *luxS_{V.h.}*. *E. coli* and *V. harveyi* are abbreviated *E.c.* and *V.h.* respectively.

[0040] Figure 12. Alignment of LuxS and YgaG protein sequences. The translated protein sequences for the AI-2 production family of proteins are shown. We determined the sequences for the *luxS_{V.h.}* gene from *V. harveyi* BB120 (SEQ ID NO:10), and the *ygaG* genes (re-named herein as *luxS_{E.C.}* from *E. coli* MG1655 (SEQ ID NO: 11), *E. coli* O157:H7 (SEQ ID NO: 11), and *E. coli* DH5 (SEQ ID NO: 18). The *S. typhimurium* LT2 *ygaG* (re-named herein *luxS_{S.T.}* partial sequence (SEQ ID NO: 12) came from the *S. typhimurium* database. Amino acid residues that are not identical to the *LuxS_{V.H.}* protein are underlined and not in bold font. The site of the frame shift mutation in the *E. coli* DH5 DNA sequence is denoted by an "*". The 20 altered amino acid residues that are translated following the frame shift are enclosed by the box.

[0041] Figure 13. A diagram of the hybrid quorum sensing circuit of *Vibrio harveyi* (is provided. The AI-1 and AI-2 circuits are independently stimulated but integrate their signals for light expression. Each pathway, however, is also independently competent to generate light. This allows for reciprocal mutations in the LuxN or LuxQ sensors to be used to construct a reporter specific for AI-2 or AI-1, respectively.

[0042] Figure 14. Response phenotypes of *V. harveyi* wild-type and lux regulatory mutants. At the first time point, cell-free culture fluids (10%), or nothing (N.A) was added. Wild-type, cell-free culture fluid (AI-1 + AI2); LuxS⁻ cell-free culture fluid (AI-1); LuxM⁻ cell-free culture fluid (AI-2). Relative light units are defined as cpm x 10³/CFU/ml.

[0043] Figure 15. A diagram of the biosynthetic pathway of autoinducer-2 (AI-2), including the structure of AI-2, is shown.

DETAILED DESCRIPTION OF THE INVENTION

[0044] In accordance with the present invention, we have identified, isolated and characterized an extracellular signaling factor produced by several strains of pathogenic bacteria, including *Salmonella typhimurium* and *Escherichia coli*, which has a role in regulating the pathogenesis or virulence of these bacteria. We have also identified and cloned genes involved in the biosynthesis of this signaling factor. The purification and/or cloning of this signaling compound and the genes that encode proteins that catalyze its biosynthesis open a new avenue for drug design aimed at either inhibition of production of or response to this compound by bacteria. Drugs that interfere with signaling by this compound will constitute a new class of antibiotics. The invention further provides methods for detecting an autoinducer and methods for the *in vitro* production of autoinducer-2.

I. Definitions:

[0045] Various terms relating to the biological compounds of the present invention are used throughout the specifications and claims. The terms "substantially the same," "percent similarity" and "percent identity" are defined in detail below.

[0046] The novel signaling factor of the present invention is alternatively referred to herein as "signaling factor", "signaling compound", "autoinducer", and more specifically, "autoinducer-2" or AI-2". The terms "autoinducer-2" and "AI-2" refer specifically to the signaling factor as produced by *Vibrio harveyi*. The terms "signaling factor" or "signaling compound", "autoinducer" or "AI-2-like compound" refer generally to the signaling factors of the present invention, of which AI-2 is an example.

[0047] The term "isolated nucleic acid", when applied to DNA, refers to a DNA that is separated from sequences with which it is immediately contiguous (in the 5' and 3' directions) in the naturally occurring genome of the organism from which it was derived. For example, the "isolated nucleic acid" may comprise a DNA inserted into a vector, such as a plasmid or virus vector, or integrated into the genomic DNA of a procaryote or eucaryote. An "isolated nucleic acid" may also comprise a cDNA.

[0048] The term "isolated nucleic acid", when applied to RNA, refers to an RNA encoded by an isolated DNA as defined above. Alternatively, the term may refer to an RNA that has been sufficiently separated from RNAs with which it would be associated in its natural state (i.e., in cells or tissues), such that it exists in a "substantially pure" form (the term "substantially pure" is defined below).

[0049] The term "isolated protein" or "isolated and purified protein" refers primarily to a protein produced by expression of an isolated nucleic acid of the invention. Alternatively, this term may refer to a protein that has been sufficiently separated from other proteins with which it would naturally be associated, so as to exist in "substantially pure" form.

[0050] The term "substantially pure" refers to a preparation comprising at least 50-60% by weight the factor of interest (e.g., pathogenesis signaling factor, nucleic acid, oligonucleotide, protein, etc.). More preferably, the preparation comprises at least 75% by weight, and most preferably 90-99% by weight, the factor of interest. Purity is measured by methods appropriate for the factor of interest (e.g. chromatographic methods, agarose or polyacrylamide gel electrophoresis, HPLC analysis, and the like).

[0051] With respect to antibodies of the invention, the term "immunologically specific" refers to antibodies that bind to one or more epitopes of a protein of interest, but that do not substantially recognize and bind other compounds in a sample containing a mixed population of antigenic biological constituents.

[0052] With respect to oligonucleotides, the term "specifically hybridizing" refers to the association between two single-stranded nucleotides of sufficiently complementary sequence to permit such hybridization under pre-determined conditions generally used in the art (sometimes termed "substantially complementary"). In particular, the term refers to hybridization of an oligonucleotide with a substantially complementary sequence contained within a single-stranded DNA or RNA of the invention, to the substantial exclusion of hybridization of the oligonucleotide with single-stranded nucleic acids of non-complementary sequence.

[0053] The term "promoter region" refers to the transcriptional regulatory regions of a gene, which may be found at the 5' or 3' side of the coding region, or within the coding region, or within introns.

[0054] The term "selectable marker gene" refers to a gene encoding a product that, when expressed, confers a selectable phenotype such as antibiotic resistance on a transformed cell.

[0055] The term "reporter gene" refers to a gene that encodes a product which is easily detectable by standard methods, either directly or indirectly.

[0056] The term "operably linked" means that the regulatory sequences necessary for expression of the coding sequence are placed in the DNA in the appropriate positions relative to the coding sequence so as to enable expression of the coding sequence. This same definition is sometimes applied to the arrangement of transcription units and other regulatory elements (e.g., enhancers or translation regulatory sequences) in an expression vector.

II. Description of the Signaling Factor

[0057] The invention provides a heterologous bio-assay that has enabled the identification of an extracellular signaling factor produced by *S. typhimurium* and *E. coli*, among other pathogenic bacteria. The factor is sometimes referred to herein as a "pathogenesis signaling" factor or compound,

though it acts as a signal for a variety of physiological changes in bacteria other than pathogenesis. The factor mimics the action of AI-2 (autoinducer-2) of the quorum sensing bacterium *Vibrio harveyi*, and it acts specifically through the *V. harveyi* Signaling System 2 detector, LuxQ.

[0058] The signaling factor is a small, soluble, heat labile organic compound that is involved in intercellular communication in all three bacteria. In *E. coli* and *Salmonella*, maximal secretion of the compound occurs in mid-exponential phase and the extracellular activity is degraded as glucose becomes depleted from the medium or by the onset of stationary phase. Destruction of the signaling compound in stationary phase indicates that, in contrast to other quorum sensing systems, quorum sensing in bacteria that utilize the signaling compound is critical for regulating behavior in the pre-stationary phase of growth. Protein synthesis is required for degradation of the activity, indicating that a complex regulatory circuitry controls quorum sensing in these enteric bacteria.

[0059] Increased signaling activity is observed if, after growing in the presence of glucose, the bacteria are transferred to a high osmolarity (e.g., 0.4 M NaCl) or to a low pH (e.g., pH 5.0) environment. Moreover, degradation of the signal is induced by conditions of low osmolarity (e.g., 0.1 M NaCl). High osmolarity and low pH are two conditions encountered by pathogenic enteric bacteria, such as *S. typhimurium* and *E. coli*, when they undergo the transition to a pathogenic existence inside a host organism. Thus, quorum sensing in these bacteria appears to play a role in regulating their virulence, by way of directing the bacteria to undergo the transition between a host-associated (i.e., pathogenic) and a free-living existence.

[0060] Other factors that regulate the activity of the signaling compound are described in greater detail in Example 2. Particularly exemplified is the regulation of the compound in *S. typhimurium*.

[0061] The timing of *lux* induction in the bio-assay and the shape of the response curve of *V. harveyi* to the *S. typhimurium* and *E. coli* signals are indistinguishable from those of *V. harveyi* responding to its own Signaling System 2 inducer, AI-2. Furthermore, each of the signaling compounds from *S. typhimurium*, *E. coli* and *V. harveyi* can be partially purified according to the same protocol. These results indicate that the signaling compounds from each of the aforementioned organisms are either identical or very closely related. Accordingly, AI-2 from *V. harveyi* is a signaling compound of the invention, but appears to play a different role in that organism than it does in pathogenic enteric bacteria such as *Salmonella* and *Escherichia*.

A. Structure of the AI-2 Signaling Factor

[0062] Thus, in another aspect, the invention provides autoinducer-2 (AI-2) signaling factor and derivatives thereof. AI-2 of the invention can be used to regulate bacterial growth in a variety of applications. The present invention provides autoinducer-2 compounds having the structure:

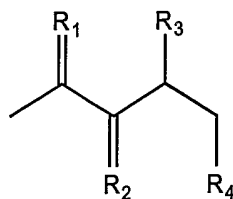

[0063] wherein R₁, R₂, R₃ and R₄ are independently selected from hydrido, halo, alkyl, haloalkyl, cycloalkyl, cycloalkenyl, heterocyclyl, methyl, cyano, alkoxy carbonyl, amino, carboxyl, hydroxyl, formyl, nitro, fluoro, chloro, bromo, methyl, aryl, heteroaryl, aralkyl, heteroarylalkyl, alkylsulfonyl, haloalkylsulfonyl, arylsulfonyl, heteroarylsulfonyl, hydroxyalkyl, mercaptoalkyl, alkoxyalkyl, aryloxyalkyl, heteroaryloxyalkyl, aralkyloxyalkyl, heteroarylalkyloxyalkyl, alkylthioalkyl, arylthioalkyl, heteroarylthioalkyl, aralkylthioalkyl, heteroarylalkylthioalkyl, haloalkylcarbonyl, haloalkyl(hydroxy)alkyl, alkylcarbonyl, arylcarbonyl, aralkylcarbonyl, heteroarylcarbonyl, heteroarylalkylcarbonyl, carboxyalkyl, alkoxy carbonylalkyl, alkylcarbonyloxyalkyl, aminoalkyl, alkylaminoalkyl, arylaminoalkyl, aralkylaminoalkyl, heteroarylaminoalkyl, heteroarylalkylaminoalkyl, alkoxy, and aryloxy; phenyl, cyclohexyl, cyclohexenyl, benzofuryl, benzodioxolyl, furyl, imidazolyl, thienyl, thiazolyl, pyrrolyl, oxazolyl, isoxazolyl, triazolyl, pyrimidinyl, isoquinolyl, quinolinyl, benzimidazolyl, indolyl, pyrazolyl and pyridyl, aminosulfonyl, fluoro, chloro, bromo, methylthio, methyl, ethyl, isopropyl, tert-butyl, isobutyl, pentyl, hexyl, cyano, methoxycarbonyl, ethoxycarbonyl, isopropoxycarbonyl, tert-butoxycarbonyl, propoxycarbonyl, butoxycarbonyl, isobutoxycarbonyl, pentoxycarbonyl, methylcarbonyl, fluoromethyl, difluoromethyl, trifluoromethyl, chloromethyl, dichloromethyl, trichloromethyl, pentafluoroethyl, heptafluoropropyl, difluorochloromethyl, dichlorofluoromethyl, difluoroethyl, difluoropropyl, dichloroethyl, dichloropropyl, methoxy, methylenedioxy, ethoxy, propoxy, n-butoxy, hydroxymethyl, hydroxyethyl, methoxymethyl, ethoxymethyl, trifluoromethoxy, methylamino, N,N-dimethylamino, phenylamino, ethoxycarbonylethyl, and methoxycarbonylmethyl, methyl, ethyl, fluoromethyl, difluoromethyl, trifluoromethyl, cyano, methoxycarbonyl, ethoxycarbonyl, tert-butoxycarbonyl, benzyl, phenylethyl, phenylpropyl, methylsulfonyl, phenylsulfonyl, trifluoromethylsulfonyl, hydroxymethyl, hydroxyethyl, methoxymethyl, ethoxymethyl, methylcarbonyl, ethylcarbonyl, trifluoromethylcarbonyl, trifluoro(hydroxy)ethyl, phenylcarbonyl, benzylcarbonyl, methoxycarbonylmethyl, ethoxycarbonylethyl, carboxymethyl, carboxypropyl, methylcarbonyloxymethyl, phenyloxy, phenyloxymethyl, thienyl, furyl, and pyridyl, wherein the thienyl, furyl, pyridyl, methylthio, methylsulfinyl, methyl, ethyl, isopropyl, tert-butyl, isobutyl, pentyl, hexyl, cyano, fluoromethyl, difluoromethyl, trifluoromethyl, chloromethyl, dichloromethyl, trichloromethyl, pentafluoroethyl, heptafluoropropyl, difluorochloromethyl, dichlorofluoromethyl, difluoroethyl, difluoropropyl, dichloroethyl, dichloropropyl, methoxy, methylenedioxy, ethoxy, propoxy, n-butoxy, hydroxymethyl, hydroxyethyl and trifluoromethoxy.

[0064] The chemical groups disclosed herein are known to those of skill in the art. In addition, alkyl groups refer to "lower alkyl" groups having one to about ten carbon atoms. Most preferred are

lower alkyl groups having one to about six carbon atoms. Examples of such groups include methyl, ethyl, n-propyl, isopropyl, n-butyl, isobutyl, sec-butyl, tert-butyl, pentyl, iso-amyl, hexyl and the like. The term "halo" means halogens such as fluorine, chlorine, bromine or iodine. The terms "carboxy" or "carboxyl" denotes $-CO_2H$. The term "carbonyl", whether used alone or with other terms, denotes $-(S=O)-$.

[0065] Preferably, the autoinducer-2 of the invention is 4,5-dihydroxy-2,3-pentanedione:

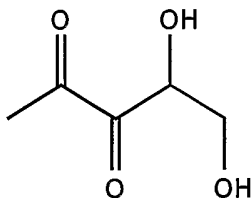

[0066] As used herein, an "autoinducer-2 (AI-2)" of the invention includes a compound that acts as a diffusible sensor for quorum sensing Signaling System 2. For example, AI-2 can regulate gene expression by increasing or decreasing expression of genes associated with pathogenesis of a microorganism. Typically, autoinducers are produced by microorganisms, such as bacteria, during metabolism. For example, the autoinducer-2 (AI-2) of the invention can interact with LuxP, which is the protein encoded by the homologue of the *luxP* gene of pathogenic bacteria such as *V. cholerae*, *S. typhimurium* and *E. coli*. In turn, the AI-2-LuxP complex can interact with LuxQ, which is the protein product encoded by the *luxQ* gene. The AI-2-LuxP-LuxQ interaction promotes luminescence in bacteria such as *Vibrio* spp. The AI-2-LuxP-LuxQ interaction has been linked to the activation of biochemical pathways required for bacterial pathogenicity. Thus, the invention provides a method for controlling bacterial gene expression and for regulating bacterial pathogenicity by modulating AI-2-LuxP-LuxQ interactions.

[0067] In another aspect, the invention provides methods for using homocysteine as an autoinducer. The structure of homocysteine is as follows:

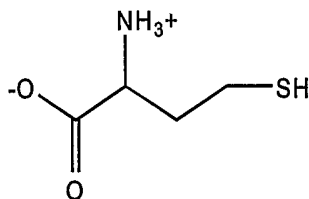

[0068] Homocysteine is produced by the activity of the LuxS protein on S-ribosylhomocysteine (Figure 15). Thus, the invention provides methods for using homoserine as an autoinducer.

[0069] The present invention also encompasses isomers of an autoinducer-2, including both optical isomers and structural isomers.

[0070] In addition to isomers, analogs of an autoinducer-2 are included in the invention. As used herein, an AI-2 "analog" includes compounds that are structurally similar but not identical to the claimed autoinducer 4,5-dihydroxy-2,3-pentanedione. Analogs of AI-2 can include compounds that inhibit rather than stimulate the activity of the LuxP protein. For example, an analog of AI-2 that can

interact nonproductively with LuxP can be produced. Such a compound can retain the ability to bind to LuxP, but the analog AI-2-LuxP complex will not be able to productively interact with LuxQ, resulting in an inhibition of bacterial pathogenicity. Thus, an AI-2 analog of the invention can inhibit bacterial pathogenesis by competing with endogenous AI-2 for binding to LuxP. In addition, an analog of AI-2 can be constructed such that the analog AI-2-LuxP complex can interact nonproductively with LuxQ. In this case, the analog AI-2-LuxP-LuxQ complex is rendered nonfunctional for subsequent biochemical processes such as, for example, transcriptional activation of genes required for pathogenicity. The invention also includes AI-2 analogs that act synergistically to enhance the ability of AI-2 to increase the activity of the LuxP protein.

B. Preparation of the Signaling Factor

[0071] Initial strategies for purifying the signaling compound of the invention resulted in a partially purified preparation comprising the compound with a specific signaling activity estimated at about 0.1 - 1.0 mg of the partially purified material stimulating a 1,000-fold increase in luminescence, as measured in the *V. harveyi* bioassay. The signaling activity does not extract quantitatively into organic solvents and it does not bind to either a cation or an anion exchange column. The compound is a small (less than 1,000 kDa), polar but uncharged organic factor. The activity is acid stable and base labile, and it is heat resistant to 80°C but not 100°C. These features of the signaling compound make clear that the compound differs from any previously described autoinducer.

[0072] The signaling factor of the present invention may be purified from its natural sources, *i.e.* the bacteria that produce it. With regard to purifying AI-2 from natural sources, altering the culture medium, *e.g.*, by adding glucose or another sugar, by increasing the osmolarity, and/or decreasing pH, can increase production of the signaling compound in *Salmonella* and other enteric bacteria, has also enabled purification of the signaling compound to near-homogeneity. Thus, the compound has now been highly purified from culture fluids of enteric bacteria (*e.g.*, *E. coli*, *S. typhimurium*) using the following protocol:

[0073] 1. Grow a culture of the signal producing enteric bacterium overnight in LB containing 0.5% glucose or another sugar (37°C, with aeration). Inoculate fresh LB containing glucose or another sugar at 0.5% with the overnight culture, at a 1:100 dilution. Grow the diluted culture to mid-exponential phase (3.5 h, 37°C, with aeration).

[0074] 2. Pellet the cells (10,000 rpm, 10 min, 4°C). Discard the culture medium. Resuspend the cells and wash in 1/10 th the original volume of low osmolarity NaCl solution (0.1 M NaCl in water).

[0075] 3. Pellet the cells again (10,000 rpm, 10 min, 4°C). Discard the low osmolarity culture fluid. Resuspend the cells in 1/10 th the original volume of high osmolarity NaCl solution (0.4 M NaCl in water). Incubate the suspension at 37°C for 2 h with aeration. During this time, increased production and secretion of the signaling compound occurs.

[0076] 4. Pellet the cells (10,000 rpm, 10 min, 4°C). Collect the supernatant containing the secreted signaling compound, filter the supernatant through a 0.2 M bacterial filter to remove any remaining cells.

[0077] 5. Evaporate the aqueous filtrate using a rotary evaporator at 30°C. Extract the dried filtrate in 1/10 th the original volume of chloroform:methanol (70:30).

[0078] 6. Evaporate the organic extract using a rotary evaporator at room temperature. Redissolve the dried extract in methanol at 1/100 th of the original volume.

[0079] 7. Subject the partially purified signal to High Performance Liquid Chromatography (HPLC), using a preparative reverse phase C18 column. Elute the compound with a linear gradient of 0-100% acetonitrile in water at 5 ml per minute. Collect 30 fractions, 5 ml each.

[0080] 8. Assay the HPLC fractions in the *V. harveyi* BB170 AI-2 assay, and pool the active fractions.

[0081] The product from the C18 column contains the signaling compound and a small number of other organic compounds. This highly purified preparation of the signaling compound has activity 50-100 times greater than that of the partially purified material described above (the preparation of which did not include the high osmoticum step or the final HPLC step), i.e., 1-10 µg material stimulates a 1,000-fold increase in luminescence in the *V. harveyi* bioassay.

[0082] Subsequent strategies for purifying the AI-2 signaling compound have led to the identification of a novel *in vitro* system for producing AI-2. Thus, in addition to providing a cloned, overexpressed and purified *S. typhimurium* LuxS protein, the present invention also provides a method for producing AI-2 *in vitro*. The present invention provides a mechanism for generating large quantities of pure AI-2 useful for mass spectral and NMR analysis, and for screening compounds which regulate the activity of AI-2. Moreover, the present invention provides a method for determining the *in vivo* biosynthetic pathway for AI-2 synthesis. The *in vitro* method for AI-2 production is described below in Example 5 and Figure 15. The method provides a novel means for efficiently producing autoinducers for further study. The method also provides a means for producing substantial quantities of AI-2 for use in commercial applications. Such applications include, but are not limited to, adding AI-2 of the invention to a growth medium to increase bacterial growth. Such a method is particularly useful in the production of antibiotics from cultured bacteria. The addition of AI-2 can increase the antibiotic production of such organisms by promoting cell growth. Preferably, the signaling factor AI-2 is produced by the *in vitro* method set forth in Example 5 of the disclosure.

C. Uses of the Signaling Factor

[0083] The isolated and purified signaling compounds of the present invention are used as targets for the design of compounds that regulate the activity of AI-2. As used herein, "regulate" includes increasing or decreasing the activity of AI-2. As used herein, the "activity" of AI-2 encompasses any aspect of the compound's ability to act as a signaling factor in bacterial quorum sensing. A "compound"

can be any agent or composition that effects the activity of AI-2. For example, a compound of the invention can be a nucleic acid, a protein or small molecule. Thus, the invention provides a means for identifying a new class of antibiotics that inhibit the activity of the AI-2 or otherwise block the signaling pathway in which the compound participates. Such inhibitors may be identified by large-scale screening of a variety of test compounds, using the *V. harveyi* bioassay in the presence of the purified signaling compound. A reduction in signaling activity in the presence of a test compound would be indicative of the ability of that compound to inhibit the activity of the signaling compound or to block some other part of the pathogenesis signaling pathway.

[0084] Further, the invention provides a basis for the rational design of specific inhibitors or non-functional analogs of AI-2. Such structure-specific inhibitors or analogs may be tested in the *V. harveyi* bioassay for their ability to inhibit the signaling compound or to block the pathogenesis signaling pathway.

[0085] The invention also encompasses methods for identifying naturally produced compounds that inhibit the activity of a signaling compound such as autoinducer-2. For example, a defensive strategy employed by eucaryotic organisms to avoid bacterial colonization is to specifically target and inhibit quorum sensing controlled functions. Such a mechanism has been identified in *D. pulchra*. Recent studies indicate that halogenated furanones produced by *D. pulchra* inhibit quorum sensing by competing for the homoserine-lactone (HSL) autoinducer-binding site in LuxR. Thus, by providing a novel autoinducer and the cellular components that interact with the autoinducer, the present invention also provides a method to screen naturally produced compounds for their effect on quorum sensing system-2. For example, naturally produced compounds can be screened for their effect on the autoinducer-2-LuxP interaction. Alternatively, such compounds can be screened for their effect on autoinducer-2-LuxP-LuxQ interactions.

[0086] It will be appreciated by persons skilled in the art that, now that targets for the signaling compound have been identified in *E. coli*, inhibition of the *E. coli* target can also be used to screen potential signaling compound inhibitors or analogs. The inventors have prepared a *ler-lacZ* reporter fusion construct to be used in testing for reduction of expression of the Type III secretion gene in *E. coli* O157:H7 (pathogenic strain) directly. Furthermore, a similar locus exists in *S. typhimurium*.

[0087] Thus, the invention provides a method for selecting inhibitors or synergists of the autoinducer-2, 4,5-dihydroxy-2,3-pentanedione. As used herein, an "inhibitor" of AI-2 is intended to include compounds that interfere with the ability of the autoinducer to act as a signal for luminescence or pathogenesis. Inhibitors include compounds that degrade or bind to AI-2. The method comprises contacting the autoinducer with a suspected inhibitor or synergist, measuring the ability of the treated autoinducer to stimulate the activity of a selected gene then determining whether the suspected inhibitor or synergist represses or enhances the activity of the autoinducer. Actual inhibitors and synergists of the autoinducer are then selected. For example, a suspected inhibitor can be mixed with 4,5-dihydroxy-2,3-

pentanedione and the mixture then combined with a reporter strain of *V. harveyi* disclosed herein. The amount of luminescence in the presence of the suspected inhibitor can be compared with a control mixture that does not include the inhibitor. A decrease in luminescence indicates AI-2 inhibition. In this manner, compounds that regulate bacterial pathogenesis can be rapidly screened.

[0088] One aspect of the invention is a method for identifying a compound that modulates (i.e. increases or decreases) the response to an autoinducer that is not an acyl-homoserine lactone. Such compounds may be useful either as antimicrobial agents or as therapeutic agents. In some embodiments, the autoinducer may be AI-2 from *Vibrio harveyi*, a pentadione, or 4,5-dihydroxy-2,3-pentadione. A cell that produces a detectable signal in response to the autoinducer is obtained and the response of the cell to the autoinducer is measured in the presence and absence of a test compound. The responses of the cells to the autoinducer in the presence and absence of the test compound are compared to determine whether the compound modulates the response to the autoinducer.

[0089] The cell may be from any desired species that produces a detectable signal in response to the autoinducer or a cell that has been engineered to produce a detectable signal in response to the autoinducer. In some embodiments, the cell is a *Vibrio harveyi* cell. In other embodiments, the cell may be a *Salmonella typhimurium*, *E. coli*, *Haemophilus influenza*, *Helicobacter pylori*, *Bacillus subtilis*, *Borrelia burgdorferi* or *Vibrio cholerae* cell.

[0090] The cell may produce any detectable signal in response to the autoinducer. For example, in some embodiments, the cell produces bioluminescence in response to the autoinducer. Thus, in some embodiments, the cell is a *Vibrio harveyi* cell that produces bioluminescence in response to the autoinducer via induction of the *luxCDABE* operon.

[0091] Alternatively, in some embodiments, the detectable signal may be induction of mRNA transcription or protein expression in response to the autoinducer. Induction of mRNA transcription may be measured with any of a variety of techniques familiar to those skilled in the art, including Northern analysis or detection of the transcript through use of nucleic acid amplification techniques such as PCR. Induction of protein expression may also be measured with any of a variety of techniques familiar to those skilled in the art including gel electrophoresis, Western blotting, or enzymatic activity assays. For example, in some embodiments, the cell may be genetically engineered to express a marker protein such as β -galactosidase, chloramphenicol acetyltransferase, β -glucuronidase, luciferase or green fluorescent protein in response to the autoinducer. Thus, in some embodiments, a nucleic acid encoding the marker protein may be operably linked to the *luxCDABE* promoter and introduced into the cell such that expression of the marker protein is induced by the autoinducer. Alternatively, in other embodiments, an autoinducer responsive promoter other than the *luxCDABE* promoter may be operably linked to a nucleic acid encoding the marker protein. The the autoinducer responsive promoter may be from the same species as the cell to be used in the method or, alternatively, the the autoinducer responsive promoter may be from a heterologous organism.

[0092] The response of the cell to the autoinducer is measured in the presence and absence of a test compound. The test compound may be naturally-occurring, such as a compound from a natural products library, or may be of synthetic origin, such as a compound generated through use of combinatorial chemistry.

[0093] The response of the cell to the autoinducer in the presence and absence of the test compound is compared. In some embodiments, the test compound alters the response to the autoinducer at least two fold, at least 10 fold, at least 20 fold, at least 50 fold, at least 100 fold, at least 1000 fold, or even more than 1000 fold.

[0094] In some embodiments, the cell that produces a detectable signal in response to the autoinducer has a genetic alteration that inhibits production of the autoinducer. In some embodiments, the genetic alteration is introduced into the cell through use of such genetic engineering techniques as site directed mutagenesis, insertional mutagenesis, or chemical mutagenesis followed by appropriate selection. Alternatively, cells containing the genetic alteration may be isolated or selected from a natural population.

[0095] In some embodiments, the genetic alteration that inhibits production of the autoinducer is in the *Vibrio harveyi luxS* gene, a gene having homology to the *Vibrio harveyi luxS* gene, or a gene encoding a polypeptide having homology to the *Vibrio harveyi luxS* polypeptide. For example, the genetic alteration may be in a gene having a nucleotide sequence with at least 50%, at least 60%, or at least 80% sequence homology to the *Vibrio harveyi luxS* gene. In other embodiments the genetic alteration is in a gene encoding a polypeptide having at least 57% or at least 85% homology to the *Vibrio harveyi luxS* polypeptide. In still further embodiments, the genetic alteration is in a gene encoding a polypeptide having at least 32%, at least 45%, at least 74% or at least 80% amino acid sequence identity to the *Vibrio harveyi luxS* polypeptide.

[0096] In some embodiments, the cells have a first genetic alteration that inhibits production of an autoinducer that is not an acyl-homoserine lactone and a second genetic alteration that inhibits detection or response to another autoinducer that is an acyl-homoserine lactone. For example, in some embodiments, the cell is a *Vibrio harveyi* cell, the first genetic alteration is in the *luxS* gene and the second genetic alteration is in the *luxN* gene. Thus, in some embodiments, the cell may be a *Vibrio harveyi* MM32 cell as described herein. However, the first and second genetic alterations may be in any gene that provides the phenotypes discussed above, including the genes discussed above, and the cell may be from any suitable species, including the species specifically enumerated herein.

[0097] In another aspect, the invention also provides methods of selecting inhibitory and synergistic analogs of AI-2. The method comprises mixing a known amount of the autoinducer with a known amount of the suspected inhibitory or synergistic analog, measuring the ability of the treated autoinducer to stimulate the activity of a selected gene then determining whether the suspected inhibitory

or synergistic analog represses or enhances the activity of the autoinducer. Actual inhibitory or synergistic analogs of the autoinducer are then selected.

[0098] Autoinducer-2 can be purified from the native source through use of conventional purification techniques, derived synthetically by chemical means, or preferably, produced by the *in vitro* method of the invention described below. As used herein, "purified from a native source" includes an autoinducer-2 of the above formula that has been manufactured by an organism. "Purified from the native source" includes isolating the autoinducer from the culture medium or cytoplasm of bacteria such as *S. typhimurium* through use of conventional purification techniques. As used herein, "synthesized by chemical means" includes autoinducers of the claimed formula that have been artificially produced outside of an organism. The invention includes an autoinducer of the invention manufactured by a person skilled in the art from chemical precursors through use of standard chemical synthesis techniques.

[0099] The invention further provides methods of inhibiting the infectivity of a pathogenic organism as well as therapeutic compositions containing an AI-2 analog or AI-2 inhibitor of the invention. The methods comprise administering to a subject a therapeutically effective amount of a pharmaceutical composition that inhibits the activity of AI-2. As used herein, "inhibiting infectivity" includes methods of affecting the ability of a pathogenic organism to initially infect or further infect a subject that would benefit from such treatment. A pharmaceutical composition of the invention can include, but is not restricted to, an agent that prevents the transcriptional activation of extracellular virulence factors such as exotoxin A and elastolytic proteases. As used herein, an "agent" includes compounds that inhibit the ability of the LuxP protein and LuxQ protein to activate transcription of extracellular virulence factors. Agents include inhibitors that interact directly with AI-2 such that AI-2 is prevented from acting as a sensor for quorum sensing Signaling System-2. Preferably, the agent interacts with 4,5-dihydroxy-2,3-pentanedione. Agents further include analogs of AI-2 that can compete with 4,5-dihydroxy-2,3-pentanedione for binding to LuxP or LuxQ.

[0100] The invention further provides pharmaceutical compositions for preventing or treating pathogen-associated diseases by targeting factors involved in the Signaling System type-2 pathway. For example, LuxP or LuxQ, or homologues thereof, provide a common target for the development of a vaccine. Antibodies raised to LuxP or LuxQ, or homologues thereof, can inhibit the activation of bacterial pathways associated with virulence. Thus, LuxP and LuxQ provide common antigenic determinants which can be used to immunize a subject against multiple pathogen-associated disease states. For example, the autoinducer Signaling System type-2 is believed to exist in a broad range of bacterial species including bacterial pathogens. As discussed above, the autoinducer-2 signaling factor is believed to be involved in inter-species as well as intra-species communication. In order for the quorum sensing Signaling System type-2 to be effective for inter-species communication, it is likely to be highly conserved among various bacterial species. Thus, challenging a subject with the LuxP or LuxQ polypeptide, or an antigenic fragment thereof, isolated from a particular organism may confer protective

immunity to other disease states associated with a different organism. For example, a vaccine developed to the LuxP protein isolated from *V. cholerae* may be capable of cross-reacting with a LuxP homologue expressed by a different organism. Thus, it is envisioned that methods of the present invention can be used to treat pathogen-associated disease states.

[0101] Generally, the terms "treating", "treatment", and the like are used herein to mean obtaining a desired pharmacologic and/or physiologic effect. The effect may be prophylactic in terms of completely or partially preventing a spirochete infection or disease or sign or symptom thereof, and/or may be therapeutic in terms of a partial or complete cure for an infection or disease and/or adverse effect attributable to the infection or disease. "Treating" as used herein covers any treatment of (e.g., complete or partial), or prevention of, an infection or disease in a mammal, particularly a human, and includes:

[0102] (a) preventing the disease from occurring in a subject that may be predisposed to the disease, but has not yet been diagnosed as having it;

[0103] (b) inhibiting the infection or disease, *i.e.*, arresting its development; or

[0104] (c) relieving or ameliorating the infection or disease, *i.e.*, cause regression of the infection or disease.

[0105] Thus, the invention includes various pharmaceutical compositions useful for ameliorating symptoms attributable to a bacterial infection or, alternatively, for inducing a protective immune response to prevent such an infection. For example, a pharmaceutical composition according to the invention can be prepared to include an antibody against, for example, LuxP or LuxQ, a peptide or peptide derivative of LuxP or LuxQ, a LuxP or LuxQ mimetic, or a LuxP or LuxQ-binding agent according to the present invention into a form suitable for administration to a subject using carriers, excipients and additives or auxiliaries. Frequently used carriers or auxiliaries include magnesium carbonate, titanium dioxide, lactose, mannitol and other sugars, talc, milk protein, gelatin, starch, vitamins, cellulose and its derivatives, animal and vegetable oils, polyethylene glycols and solvents, such as sterile water, alcohols, glycerol and polyhydric alcohols. Intravenous vehicles include fluid and nutrient replenishers. Preservatives include antimicrobial, anti-oxidants, chelating agents and inert gases. Other pharmaceutically acceptable carriers include aqueous solutions, non-toxic excipients, including salts, preservatives, buffers and the like, as described, for instance, in *Remington's Pharmaceutical Sciences*, 15th ed. Easton: Mack Publishing Co., 1405-1412, 1461-1487 (1975) and *The National Formulary XIV.*, 14th ed. Washington: American Pharmaceutical Association (1975). The pH and exact concentration of the various components of the pharmaceutical composition are adjusted according to routine skills in the art. See Goodman and Gilman's *The Pharmacological Basis for Therapeutics* (7th ed.).

[0106] The pharmaceutical compositions according to the invention may be administered locally or systemically. By "therapeutically effective dose" is meant the quantity of a compound according to the invention necessary to prevent, to cure or at least partially arrest the symptoms of the

disease and its complications. Amounts effective for this use will, of course, depend on the severity of the disease and the weight and general state of the patient. Typically, dosages used *in vitro* may provide useful guidance in the amounts useful for *in situ* administration of the pharmaceutical composition, and animal models may be used to determine effective dosages for treatment of particular disorders. Various considerations are described, *e.g.*, in Langer, *Science*, 249: 1527, (1990); Gilman *et al.* (eds.) (1990).

[0107] As used herein, "administering a therapeutically effective amount" is intended to include methods of giving or applying a pharmaceutical composition of the invention to a subject which allow the composition to perform its intended therapeutic function. The therapeutically effective amounts will vary according to factors such as the degree of infection in a subject, the age, sex, and weight of the individual. Dosage regimens can be adjusted to provide the optimum therapeutic response. For example, several divided doses can be administered daily or the dose can be proportionally reduced as indicated by the exigencies of the therapeutic situation.

[0108] The pharmaceutical composition can be administered in a convenient manner such as by injection (subcutaneous, intravenous, etc.), oral administration, inhalation, transdermal application, or rectal administration. Depending on the route of administration, the pharmaceutical composition can be coated with a material to protect the pharmaceutical composition from the action of enzymes, acids and other natural conditions which may inactivate the pharmaceutical composition. The pharmaceutical composition can also be administered parenterally or intraperitoneally. Dispersions can also be prepared in glycerol, liquid polyethylene glycols, and mixtures thereof and in oils. Under ordinary conditions of storage and use, these preparations may contain a preservative to prevent the growth of microorganisms.

[0109] Pharmaceutical compositions suitable for injectable use include sterile aqueous solutions (where water soluble) or dispersions and sterile powders for the extemporaneous preparation of sterile injectable solutions or dispersions. In all cases, the composition must be sterile and must be fluid to the extent that easy syringability exists. It must be stable under the conditions of manufacture and storage and must be preserved against the contaminating action of microorganisms such as bacteria and fungi. The carrier can be a solvent or dispersion medium containing, for example, water, ethanol, polyol (for example, glycerol, propylene glycol, and liquid polyethylene glycol, and the like), suitable mixtures thereof, and vegetable oils. The proper fluidity can be maintained, for example, by the use of a coating such as lecithin, by the maintenance of the required particle size in the case of dispersion and by the use of surfactants. Prevention of the action of microorganisms can be achieved by various antibacterial and antifungal agents, for example, parabens, chlorobutanol, phenol, ascorbic acid, thimerosal, and the like. In many cases, it will be preferable to include isotonic agents, for example, sugars, polyalcohols such as mannitol, sorbitol, sodium chloride in the composition. Prolonged absorption of the injectable compositions can be brought about by including in the composition an agent which delays absorption, for example, aluminum monostearate and gelatin.

[0110] Sterile injectable solutions can be prepared by incorporating the pharmaceutical composition in the required amount in an appropriate solvent with one or a combination of ingredients enumerated above, as required, followed by filtered sterilization. Generally, dispersions are prepared by incorporating the pharmaceutical composition into a sterile vehicle which contains a basic dispersion medium and the required other ingredients from those enumerated above.

[0111] The pharmaceutical composition can be orally administered, for example, with an inert diluent or an assimilable edible carrier. The pharmaceutical composition and other ingredients can also be enclosed in a hard or soft shell gelatin capsule, compressed into tablets, or incorporated directly into the individual's diet. For oral therapeutic administration, the pharmaceutical composition can be incorporated with excipients and used in the form of ingestible tablets, buccal tablets, troches, capsules, elixirs, suspensions, syrups, wafers, and the like. Such compositions and preparations should contain at least 1% by weight of active compound. The percentage of the compositions and preparations can, of course, be varied and can conveniently be between about 5 to about 80% of the weight of the unit. The amount of pharmaceutical composition in such therapeutically useful compositions is such that a suitable dosage will be obtained.

[0112] The tablets, troches, pills, capsules and the like can also contain the following: a binder such as gum tragacanth, acacia, corn starch or gelatin; excipients such as dicalcium phosphate; a disintegrating agent such as corn starch, potato starch, alginic acid and the like; a lubricant such as magnesium stearate; and a sweetening agent such as sucrose, lactose or saccharin or a flavoring agent such as peppermint, oil of wintergreen, or cherry flavoring. When the dosage unit form is a capsule, it can contain, in addition to materials of the above type, a liquid carrier. Various other materials can be present as coatings or to otherwise modify the physical form of the dosage unit. For instance, tablets, pills, or capsules can be coated with shellac, sugar or both. A syrup or elixir can contain the agent, sucrose as a sweetening agent, methyl and propylparabens as preservatives, a dye and flavoring such as cherry or orange flavor. Of course, any material used in preparing any dosage unit form should be pharmaceutically pure and substantially non-toxic in the amounts employed. In addition, the pharmaceutical composition can be incorporated into sustained-release preparations and formulations.

[0113] As used herein, a "pharmaceutically acceptable carrier" is intended to include solvents, dispersion media, coatings, antibacterial and antifungal agents, isotonic and absorption delaying agents, and the like. The use of such media and agents for pharmaceutically active substances is well known in the art. Except insofar as any conventional medium or agent is incompatible with the pharmaceutical composition, use thereof in the therapeutic compositions and methods of treatment is contemplated. Supplementary active compounds can also be incorporated into the compositions.

[0114] It is especially advantageous to formulate parenteral compositions in dosage unit form for ease of administration and uniformity of dosage. Dosage unit form as used herein refers to physically discrete units suited as unitary dosages for the individual to be treated; each unit containing a

predetermined quantity of pharmaceutical composition is calculated to produce the desired therapeutic effect in association with the required pharmaceutical carrier. The specification for the novel dosage unit forms of the invention are dictated by and directly dependent on (a) the unique characteristics of the pharmaceutical composition and the particular therapeutic effect to be achieved, and (b) the limitations inherent in the art of compounding such a pharmaceutical composition for the treatment of a pathogenic infection in a subject.

[0115] The principal pharmaceutical composition is compounded for convenient and effective administration in effective amounts with a suitable pharmaceutically acceptable carrier in an acceptable dosage unit. In the case of compositions containing supplementary active ingredients, the dosages are determined by reference to the usual dose and manner of administration of the said ingredients.

[0116] In addition to generating antibodies which bind to antigenic epitopes of proteins of the invention, it is further envisioned that the method of the invention can be used to induce cellular responses, particularly cytotoxic T-lymphocytes (CTLs), to antigenic epitopes of, for example LuxP or LuxQ. Typically, unmodified soluble proteins fail to prime major histocompatibility complex (MHC) class I-restricted CTL responses whereas particulate proteins are extremely immunogenic and have been shown to prime CTL responses *in vivo*. CTL epitopes and helper epitopes have been identified in proteins from many infectious pathogens. Further, these epitopes can be produced concurrently such that multiple epitopes can be delivered in a form that can prime MHC class I restricted CTL responses. An example of a system that can produce recombinant protein particles carrying one or more epitopes entails the use of the p1 protein of the retrotransposon Ty1 of *Saccharomyces cerevisiae* (Adams, *et al.*, *Nature*, 329:68, 1987). Sequences encoding CTL epitopes can, for example, be fused to the C-terminus of p1 and the resulting Ty virus-like particles (Ty-VLPs) may be able to generate a CTL response. Thus, conserved regions of pathogenic antigens, such as those that are involved in, or result from, the activation of Signaling System type-2, can be identified and incorporated together in a particle which enables the host immune system to mount an effective immune response against multiple spirochetal organisms. Further, the method of the invention can be used to generate particles with multiple epitopes to a single protein, such as LuxP, or multiple epitopes from various proteins.

[0117] The method of the invention also includes slow release antigen delivery systems such as microencapsulation of antigens into liposomes. Such systems have been used as an approach to enhance the immunogenicity of proteins without the use of traditional adjuvants. Liposomes in the blood stream are generally taken up by the liver and spleen, and are easily phagocytosed by macrophages. Liposomes also allow co-entrapment of immunomodulatory compounds along with the antigens, so that such compounds may be delivered to the site of antigen encounter, allowing modulation of the immune system towards protective responses.

[0118] In another embodiment, the invention provides a method for identifying a compound that binds to a protein of the invention, such as LuxP or LuxQ. The method includes incubating

components comprising the compound and LuxP or LuxQ under conditions sufficient to allow the components to interact and measuring the binding of the compound to LuxP or LuxQ. Compounds that bind to LuxP or LuxQ include peptides, peptidomimetics, polypeptides, chemical compounds and biologic agents as described above.

[0119] Incubating includes conditions which allow contact between the test compound and LuxP or LuxQ. Contacting includes in solution and in solid phase. The test ligand(s)/compound may optionally be a combinatorial library for screening a plurality of compounds. Compounds identified in the method of the invention can be further evaluated, detected, cloned, sequenced, and the like, either in solution or after binding to a solid support, by any method usually applied to the detection of a specific DNA sequence such as PCR, oligomer restriction (Saiki, *et al.*, *Bio/Technology*, 3:1008-1012, 1985), allele-specific oligonucleotide (ASO) probe analysis (Conner, *et al.*, *Proc. Natl. Acad. Sci. USA*, 80:278, 1983), oligonucleotide ligation assays (OLAs) (Landegren, *et al.*, *Science*, 241:1077, 1988), and the like. Molecular techniques for DNA analysis have been reviewed (Landegren, *et al.*, *Science*, 242:229-237, 1988). Also included in the screening method of the invention are combinatorial chemistry methods for identifying chemical compounds that bind to LuxP or LuxQ. See, for example, Plunkett and Ellman, "*Combinatorial Chemistry and New Drugs*", *Scientific American*, April, p.69, (1997).

[0120] The invention further provides a method for promoting the production of a bacterial product, such as, for example, an antibiotic, by contacting a culture of bacteria with an AI-2 of the invention at a concentration effective to stimulate or promote cellular metabolism, growth or recovery. For example, it is known that antibiotic-producing bacteria only produce an antibiotic at or near the peak of log phase growth. By contacting a culture medium containing such antibiotic-producing bacteria with AI-2 of the invention, production of an antibiotic can be induced at an earlier phase of growth. Thus, AI-2 of the invention provides a method for increasing the amount of antibiotic produced by a culture. "Culture medium", as used herein, is intended to include a substance on which or in which cells grow. The autoinducer can be included in commercially available cell culture media including broths, agar, and gelatin.

[0121] The invention further provides a method for identifying factors that degrade or inhibit synthesis autoinducer-2. For example, it is known that autoinducer-1 concentration peaks in mid- to late log phase of a bacterial cell culture. In contrast, autoinducer-2 concentration increases earlier in log phase of bacterial cell culture growth and is present in lower amounts in late log phase and stationary phase. This data indicates that a mechanism exists for the degradation of autoinducer-2 at a specific point in bacterial growth. By providing isolated and purified autoinducer-2, the invention allows for the identification of the mechanism whereby autoinducer-2 levels are controlled. For example, partially purified bacterial extracts can be assayed against isolated autoinducer-2 to identify those fractions which degrade autoinducer-2. Fractions that degrade autoinducer-2 can be further fractionated by techniques

known to those skilled in the art until those cellular components involved in autoinducer degradation are isolated.

[0122] The present invention also provides a method of regulating the expression of a gene. The method comprises inserting a gene into bacteria chosen for enhancement of gene expression by an agent capable of stimulating the activity of the LuxQ protein and incubating the bacteria with an agent capable of stimulating the activity of the LuxP protein. Thus, the signaling compound of the invention can also be used in screens for other targets that it regulates. Cloned promoter-fusion libraries can be prepared from any species of bacteria and these libraries can be used to identify genes that are induced or repressed by the signaling factor, simply by screening for differences in reporter activity in Petri or microtiter plates containing the signaling compound compared to plates that do not contain the compound.

[0123] In addition, quorum sensing is a major regulator of biofilm control and quorum sensing blockers can therefore be used to prevent and/or inhibit biofilm formation. Also, quorum sensing blockers are effective in removing, or substantially decreasing the amount of, biofilms which have already formed on a surface. Thus, by providing the structure of autoinducer-2 (AI-2), the present invention provides a new approach to identifying compounds which inhibit bacterial infections by regulating biofilm formation.

[0124] It is known that quorum sensing blockers can reduce protease production by 50% in some strains of bacteria but the discovery that certain compounds can substantially eliminate protease production imparts clear clinical advantages. Furthermore, the unexpected finding that biofilm formation can be inhibited or prevented by quorum sensing blockers leads to the reasonable conclusion that other quorum sensing blockers that are known to exhibit quorum sensing blocking in other systems, such as protease production, will also be effective against biofilm formation.

[0125] The compounds of the invention are advantageously used to treat and/or prevent infections, such as those caused by *V. anguillarum* or *Aeromonas spp.* Examples of this type of infection are vibriosis and furunculosis disease in fish. Inhibition of biofilm formation by the bacteria, optionally together with a reduction or elimination of extracellular protease production, renders the bacteria substantially non-pathogenic. The compounds of the invention may be formulated by conventional methods for use in the treatment and/or prevention of bacterial infection. For example, the compounds may be used as solid or liquid preparations (such as tablets, suspensions or solutions for oral administration or sterile injectable compositions), optionally together with pharmaceutically acceptable diluents, carriers or other additives.

[0126] For the treatment of vibriosis or furunculosis disease in fish, the compounds or compositions containing them may be applied directly to the fish or they may be added to the fish's food or water.

[0127] In another embodiment, the invention provides a method of removing a biofilm from a surface that comprises treating the surface with a compound of the invention. The surface is preferably the inside of an aqueous liquid distribution system, such as a drinking water distribution system or a supply line connected to a dental air-water system. The removal of biofilms from this type of surface can be particularly difficult to achieve. The compound is preferably applied to the surface as a solution of the compound either alone or together with other materials such as conventional detergents or surfactants.

[0128] A further embodiment of the invention is an antibacterial composition comprising a compound of the invention together with a bacteriocidal agent. In the antibacterial compositions, the compound of the invention helps to remove the biofilm whilst the bacteriocidal agent kills the bacteria. The antibacterial composition is preferably in the form of a solution or suspension for spraying and/or wiping on a surface.

[0129] In yet another aspect, the invention provides an article coated and/or impregnated with a compound of the invention in order to inhibit and/or prevent biofilm formation thereon. The article is preferably of plastics material with the compound of the invention distributed throughout the material.

III. Description of Nucleic Acids Encoding Proteins Involved in Signaling Factor Biosynthesis

[0130] In accordance with another aspect of the present invention, we have cloned and characterized the genes responsible for production of the signaling compound of the invention in *V. harveyi*, *S. typhimurium* and *E. coli*. These genes encode a novel family of proteins responsible for autoinducer production. We have designated the members of this family of autoinducer production genes as *luxS*, specifically *luxS_{E.c.}*, *luxS_{S.t.}*, and *luxS_{V.h.}* for *E. coli*, *S. typhimurium* and *V. harveyi* respectively.

[0131] Mutagenesis of *luxS* in *V. harveyi*, *S. typhimurium* and *E. coli* eliminates production of the signaling compound in all three species of bacteria. *S. typhimurium* could be complemented to full production of the compound by the introduction of either the *E. coli* O157:H7 *luxS_{E.c.}* gene or the *V. harveyi* BB120 *luxS_{V.h.}* gene. These results indicate that both the *E. coli* and *V. harveyi* LuxS proteins can function with *S. typhimurium* cellular components to produce the signaling compound. *E. coli* DH5 was only partially complemented to production of the signaling compound by the introduction of either the *E. coli* O157:H7 *luxS_{E.c.}* or the *V. harveyi* BB120 *luxS_{V.h.}* gene. Because *in trans* expression of *luxS* genes in *E. coli* DH5 did not completely restore signaling compound production, other biochemical or physiological factors may contribute to signal production.

[0132] The regulation of signaling compound production differs between pathogenic and non-pathogenic strains. For example *E. coli* O157:H7 strains produce AI-2 at 30° and 37°C with or without glucose while *E. coli* K-12 strains do not produce the compound in the absence of a preferred carbon source. And, all of the *E. coli* O157 strains tested produce greater signaling activity than do non-pathogenic *E. coli* strains. Likewise, pathogenic *S. typhimurium* 14028 produces significantly more signaling activity than does *S. typhimurium* LT2.

[0133] Sequence analysis shows that the LuxS proteins are highly homologous, and complementation data suggest that the proteins can function across species. These results indicate that the enzymatic activity carried out by the LuxS proteins and any other cellular machinery that contributes to synthesis of the signaling compound are conserved. We did not identify any amino acid sequence motif in the LuxS proteins that is indicative of a particular function. Therefore, the LuxS proteins most likely catalyze one specific enzymatic step in biosynthesis of the signaling compound. The remainder of the steps involved in signaling compound biosynthesis could be a consequence of normal intermediary metabolic processes. The *luxS* genes identified here bear no homology to other genes known to be involved in production of acyl-homoserine lactone autoinducers (*luxI*-like (Fuqua *et al.*, J. Bacteriol. 176, 269-275, 1994), *luxLM-ainS*-like (Bassler *et al.*, 1993, *supra*; Gilson *et al.*, J. Bacteriol. 177, 6946-6951, 1995), further indicating that the signaling compounds of the present invention are novel.

[0134] Database analysis of finished and unfinished bacterial genomes reveals that many other species of bacteria possess a gene homologous to *luxS* from *V. harveyi*, *S. typhimurium* and *E. coli*. The species of bacteria identified and the percent homology/identity (H/I) to the LuxS protein of *V. harveyi* are as follows: *Haemophilus influenzae* (88/72), *Helicobacter pylori* (62/40), *Bacillus subtilis* (58/38), *Borrelia burgdorferi* (52/32), *Neisseria meningitidis* (89/80), *Neisseria gonorrhoeae* (89/80), *Yersinia pestis* (85/77), *Campylobacter jejuni* (85/74), *Vibrio cholerae* (95/90), *Deinococcus radiodurans* (65/45), *Mycobacterium tuberculosis* (59/41), *Enterococcus faecalis* (60/44), *Streptococcus pneumoniae* (57/36) and *Streptococcus pyogenes* (57/36). As reported earlier (Bassler *et al.*, 1997, *supra*), a few of these species were tested for production of the signaling compound. We showed that *V. cholerae* and *Y. enterocolitica* but not *B. subtilis* produced signaling activity. We believe that *B. subtilis* does produce the compound but the environmental conditions that induce its synthesis have not yet been determined. Furthermore, we believe that all of the species identified in the database analysis produce an AI-2-like compound.

[0135] The nucleotide sequences of the *luxS* genes from *V. harveyi*, *E. coli* and *S. typhimurium* are set forth at the end of the specification as SEQ ID NO:1, SEQ ID NO:2 and SEQ ID NOS:3 and 4, respectively (the sequences read in the 5' to 3' direction). These genes are sometimes referred to herein as "*LuxS_{V.h.}*", "*LuxS_{E.c.}*" and "*LuxS_{S.t.}*", respectively. The amino acid sequences deduced from SEQ ID NOS: 1-4 are set forth at the end of the specification (and in Figure 11) as SEQ ID NO:10, SEQ ID NO:11 and SEQ ID NO:12, respectively. It is believed that SEQ ID NOS:1 and 2 constitute full-length clones, whereas SEQ ID NO:3 and SEQ ID NO:4 do not.

[0136] The *LuxS* genes from *V. harveyi*, *E. coli* and *S. typhimurium* are described in greater detail in Example 3. Although those particular *LuxS* genes and their encoded proteins are exemplified herein, this invention encompasses *LuxS* genes and their encoded enzymes from any bacterial species, having the sequence, structural and functional properties of the *LuxS*-encoded proteins described herein.

As mentioned in Example 3, homologous nucleic acid sequences have been identified in a variety of bacterial species, but identity of those sequences as *LuxS* genes heretofore had not been appreciated. *LuxS* nucleotide and deduced amino acid sequences from other bacterial species are set forth at the end of the specification as SEQ ID NOS: 5-9 and 13-17, respectively, and include sequences from the following species: *Haemophilus influenzae*, *Helicobacter pylori*, *Bacillus subtilis*, *Borrelia burgdorferi* and *Vibrio cholerae*.

[0137] In addition to *LuxS* homologs from species other than *V. harveyi*, *E. coli* or *S. typhimurium*, variants and natural mutants of SEQ ID NOS:1-9 are likely to exist within different species or strains of *Vibrio*, *Escherichia* and *Salmonella* (indeed, *E. coli* strain DH5 possesses a non-functional mutant form of the gene). Because such variants are expected to possess certain differences in nucleotide and amino acid sequence, this invention provides an isolated *LuxS* nucleic acid and encoded protein having at least about 50-60% (preferably 60-80%, most preferably over 80%) sequence homology or sequence identity in the coding region with the nucleotide sequences set forth as SEQ ID NOS:1-9, respectively (and, preferably, specifically comprising the coding regions of SEQ ID NOS:1-9), and the amino acid sequence of SEQ ID NOS:10-17. Because of the natural sequence variation likely to exist among these proteins and nucleic acids encoding them, one skilled in the art would expect to find up to about 40-50% sequence variation, while still maintaining the unique properties of the *LuxS*-encoded proteins of the present invention. Such an expectation is due in part to the degeneracy of the genetic code, as well as to the known evolutionary success of conservative amino acid sequence variations, which do not appreciably alter the nature of the protein. Accordingly, such variants are considered substantially the same as one another and are included within the scope of the present invention.

[0138] For purposes of this invention, the term "substantially the same" refers to nucleic acid or amino acid sequences having sequence variation that do not materially affect the nature of the protein (i.e. the structural characteristics and/or biological activity of the protein). With particular reference to nucleic acid sequences, the term "substantially the same" is intended to refer to the coding region and to conserved sequences governing expression, and refers primarily to degenerate codons encoding the same amino acid, or alternate codons encoding conservative substitute amino acids in the encoded polypeptide. With reference to amino acid sequences, the term "substantially the same" refers generally to conservative substitutions and/or variations in regions of the polypeptide not involved in determination of structure or function. The terms "percent identity" and "percent similarity" are also used herein in comparisons among amino acid sequences. These terms are intended to be defined as they are in the UWGCG sequence analysis program (Devereaux *et al.*, Nucl. Acids Res. 12: 387-397, 1984), available from the University of Wisconsin, and the default parameters used by that program are the parameters intended to be used herein to compare sequence identity and similarity.

A. Preparation of *LuxS* Nucleic acids, Encoded Proteins, and Immunologically Specific Antibodies**1. Nucleic Acids**

[0139] *LuxS* nucleic acids of the invention may be prepared by two general methods: (1) They may be synthesized from appropriate nucleotide triphosphates, or (2) they may be isolated from biological sources. Both methods utilize protocols well known in the art.

[0140] The availability of nucleotide sequence information, such as the DNAs having SEQ ID NOS:1-9, enables preparation of an isolated nucleic acid of the invention by oligonucleotide synthesis. Synthetic oligonucleotides may be prepared by the phosphoramidite method employed in the Applied Biosystems 38A DNA Synthesizer or similar devices. The resultant construct may be purified according to methods known in the art, such as high performance liquid chromatography (HPLC). Long, double-stranded polynucleotides, such as a DNA of the present invention, must be synthesized in stages, due to the size limitations inherent in current oligonucleotide synthetic methods. Such long double-stranded nucleic acids may be synthesized as several smaller segments of appropriate complementarity. Complementary segments thus produced may be annealed such that each segment possesses appropriate cohesive termini for attachment of an adjacent segment. Adjacent segments may be ligated by annealing cohesive termini in the presence of DNA ligase to construct an entire 1.8 kb double-stranded nucleic acid. A synthetic DNA so constructed may then be cloned and amplified in an appropriate vector.

[0141] *LuxS* nucleic acids also may be isolated from appropriate biological sources using methods known in the art. In a preferred embodiment, a genomic clone is isolated from a cosmid expression library of an *S. typhimurium* or *E. coli* genome. In another embodiment, a genomic clone is isolated from a cosmid library of another bacterial genome.

[0142] In accordance with the present invention, nucleic acids having the appropriate level sequence homology or nucleotide sequence identity with the protein coding region of any of SEQ ID NOS:1-9 may be identified by using hybridization and washing conditions of appropriate stringency. For example, hybridizations may be performed, according to the method of Sambrook *et al.*, using a hybridization solution comprising: 5X SSC, 5X Denhardt's reagent, 1.0% SDS, 100 g/ml denatured, fragmented salmon sperm DNA, 0.05% sodium pyrophosphate and up to 50% formamide. Hybridization is carried out at 37-42NC for at least six hours. Following hybridization, filters are washed as follows: (1) 5 minutes at room temperature in 2X SSC and 1% SDS; (2) 15 minutes at room temperature in 2X SSC and 0.1% SDS; (3) 30 minutes-1 hour at 37°C in 1X SSC and 1% SDS; (4) 2 hours at 42-65Nin 1X SSC and 1% SDS, changing the solution every 30 minutes.

[0143] One common formula for calculating the stringency conditions required to achieve hybridization between nucleic acids of a specified sequence homology (Sambrook *et al.*, 1989):

$$T_m = 81.5C + 16.6\text{Log} [\text{Na}^+] + 0.41(\% \text{G+C}) - 0.63 (\% \text{formamide}) - 600/\#\text{bp in duplex}$$

[0144] As an illustration of the above formula, using $[\text{Na}^+] = [0.368]$ and 50% formamide, with GC content of 42% and an average probe size of 200 bases, the T_m is 57C. The T_m of a DNA duplex

decreases by 1-1.5°C with every 1% decrease in homology. Thus, targets with greater than about 75% sequence identity would be observed using a hybridization temperature of 42°C.

[0145] Another way to isolate the *luxS* nucleic acids is to search the publicly available databases for the *luxS* sequence in the bacterial genome of interest, design PCR primers from the sequence and amplify the gene directly from the chromosome. The PCR product can then be cloned. Alternatively, if the complete sequence of a specific bacterial genome is not available, the sequences set forth in the present invention, or any other *luxS* sequence, may be used to design degenerate oligonucleotides for PCR amplification and cloning of *luxS* from the chromosome.

[0146] Nucleic acids of the present invention may be maintained as DNA in any convenient cloning vector. In a preferred embodiment, clones are maintained in plasmid cloning/expression vector, such as pBluescript (Stratagene, La Jolla, CA), which is propagated in a suitable *E. coli* host cell.

[0147] *LuxS* nucleic acids of the invention include DNA, RNA, and fragments thereof which may be single- or double-stranded. Thus, this invention provides oligonucleotides (sense or antisense strands of DNA or RNA) having sequences capable of hybridizing with at least one sequence of a nucleic acid of the present invention, such as selected segments of the DNA having SEQ ID NOS:1, 2 or 3. Such oligonucleotides are useful as probes for detecting *LuxS* genes or transcripts.

2. Proteins and Antibodies

[0148] A full-length *LuxS* gene product of the present invention may be prepared in a variety of ways, according to known methods. The protein may be purified from appropriate sources, e.g., cultured bacteria such as *S. typhimurium*, *E. coli* or *V. harveyi*.

[0149] The availability of full-length *LuxS* nucleic acids enables production of the encoded protein using *in vitro* expression methods known in the art. According to a preferred embodiment, the enzyme may be produced by expression in a suitable expression system. For example, part or all of a DNA, such as the DNA having SEQ ID NO:1 or 2, may be inserted into a plasmid vector adapted for expression in a bacterial cell, such as *E. coli*, or a eucaryotic cell, such as *Saccharomyces cerevisiae* or other yeast. Such vectors comprise the regulatory elements necessary for expression of the DNA in the host cell, positioned in such a manner as to permit expression of the DNA in the host cell. Such regulatory elements required for expression include promoter sequences, transcription initiation sequences and, optionally, enhancer sequences.

[0150] The protein produced by *LuxS* gene expression in a recombinant procaryotic or eucaryotic system may be purified according to methods known in the art. In a preferred embodiment, a commercially available expression/secretion system can be used, whereby the recombinant protein is expressed and thereafter secreted from the host cell, to be easily purified from the surrounding medium. If expression/secretion vectors are not used, an alternative approach involves purifying the recombinant protein by affinity separation, such as by immunological interaction with antibodies that bind specifically to the recombinant protein. Such methods are commonly used by skilled practitioners.

[0151] The protein encoded by the *LuxS* gene of the invention, prepared by one of the aforementioned methods, may be analyzed according to standard procedures. For example, the protein may be subjected to amino acid sequence analysis, according to known methods. The stability and biological activity of the enzyme may be determined according to standard methods, such as by the ability of the protein to catalyze production of the signaling compound under different conditions.

[0152] The present invention also provides antibodies capable of immunospecifically binding to the *LuxS*-encoded protein of the invention. Polyclonal antibodies may be prepared according to standard methods. In a preferred embodiment, monoclonal antibodies are prepared, which react immunospecifically with various epitopes of the protein. Monoclonal antibodies may be prepared according to general methods of Köhler and Milstein, following standard protocols. Polyclonal or monoclonal antibodies that immunospecifically interact with the *LuxS*-encoded proteins can be utilized for identifying and purifying such proteins. For example, antibodies may be utilized for affinity separation of proteins with which they immunospecifically interact. Antibodies may also be used to immunoprecipitate proteins from a sample containing a mixture of proteins and other biological molecules.

B. Uses of *LuxS* Nucleic acids, Encoded Protein and Immunologically Specific Antibodies

[0153] *LuxS* nucleic acids may be used for a variety of purposes in accordance with the present invention. DNA, RNA, or fragments thereof may be used as probes to detect the presence of and/or expression of *LuxS* genes. Methods in which *LuxS* nucleic acids may be utilized as probes for such assays include, but are not limited to: (1) *in situ* hybridization; (2) Southern hybridization (3) northern hybridization; and (4) assorted amplification reactions such as polymerase chain reactions (PCR).

[0154] The *LuxS* nucleic acids of the invention may also be utilized as probes to identify related genes from other bacteria. As is well known in the art, hybridization stringencies may be adjusted to allow hybridization of nucleic acid probes with complementary sequences of varying degrees of homology.

[0155] As described above, *LuxS* nucleic acids are also used to advantage to produce large quantities of substantially pure encoded protein, or selected portions thereof. It should be noted in this regard that the cloned genes inserted into expression vectors can be used to make large quantities of the signaling compound itself, from any selected bacterial species, in a recombinant host such as *E. coli* DH5. Specific *luxS* genes are cloned, a large quantity of the encoded protein produced, thereby producing a large quantity of the specific signaling compound. This will be particularly useful determining differences in the structures of signaling compounds from different species, if such differences are found to exist. Alternatively, a large quantity of signaling compound from the species of interest could be made using the cloned gene in an expression vector, and thereafter used in library screens for potential targets in petri plate assays, as described above.

[0156] Purified *LuxS* gene products, or fragments thereof, may be used to produce polyclonal or monoclonal antibodies which also may serve as sensitive detection reagents for the presence and accumulation of those proteins in cultured cells. Recombinant techniques enable expression of fusion proteins containing part or all of a selected *LuxS*-encoded protein. The full length protein or fragments of the protein may be used to advantage to generate an array of monoclonal or polyclonal antibodies specific for various epitopes of the protein, thereby providing even greater sensitivity for detection of the protein in cells or tissue. Other uses of the LuxS proteins include overproduction to make a quantity of the LuxS proteins sufficient for crystallization. Solving the crystal structure of the LuxS proteins would enable the exact determination of the LuxS active site for catalysis of production of the signaling compound. The LuxS crystal structure can therefore be used for computer modeling that would greatly facilitate design of signaling compound analogs, LuxS inhibitors, and rational drug design in general.

[0157] Polyclonal or monoclonal antibodies immunologically specific for a *LuxS*-encoded protein may be used in a variety of assays designed to detect and quantitate the protein. Such assays include, but are not limited to: (1) flow cytometric analysis; (2) immunochemical localization of a LuxS protein in cells or tissues; and (3) immunoblot analysis (e.g., dot blot, Western blot) of extracts from various cells and tissues. Additionally, as described above, antibodies can be used for purification of the proteins (e.g., affinity column purification, immunoprecipitation).

IV. *Vibrio Harveyi* Screening Strain

[0158] In another aspect, the invention provides a novel strain of *Vibrio Harveyi* having a genotype that is $luxN^-$, $luxS^-$. The Gram-negative bacterium *Vibrio harveyi* contains two parallel quorum sensing circuits which synthesize and detect two different autoinducers (Fig. 13). Circuit 1 synthesizes AI-1 a HSL autoinducer similar in structure to autoinducers synthesized by the LuxI/R pathway found in other Gram-negative bacteria. Circuit 2 synthesizes AI-2, the structure of which has not been determined. Synthesis of AI-1 and AI-2 is dependent on LuxLM and LuxS respectively. Following the buildup of a critical external concentration of the autoinducers, signaling occurs via a series of a phosphorylation/ dephosphorylation reactions. The AI-1 and AI-2 detectors, LuxN and LuxQ respectively, contain both a sensor kinase domain with a conserved histidine (H1) and an attached response regulator domain with a conserved aspartate (D1). Signals from both sensors are channeled to the shared integrator protein LuxU, which is phosphorylated on a histidine residue (H2). Subsequently, the signal is transduced to a conserved aspartate residue (D2) on the response regulator protein LuxO. LuxO-phosphate controls the expression of the luciferase structural operon *luxCDABE* which results in the emission of light. The presence of either AI-1 or AI-2 is sufficient to turn on light production in wild-type *V. harveyi* (strain BB120). For this reason, we have *V. harveyi* strains containing separate mutations in Lux genes L, M, S or Q which are defective in their ability to synthesize or detect AI-1 or AI-2, respectively. AI-2 is detectable using strain BB170 which is sensor 1⁻, sensor 2⁺ ($luxN^-$, $luxQ^+$). This

strain was used to detect AI-2 in diverse bacteria. The light emission response of wild type, LuxN⁻ and LuxQ⁻ phenotypes to increasing cell density is shown in figure 14.

[0159] BB170 is a sensitive reporter for AI-2, however, the BB170 strain is not optimal for use as a reporter for inhibitors of the quorum pathway in a microtiter based assay. The desired strain is defective in its ability to detect AI-1 (sensor 1⁻) and defective in its ability to synthesize AI-2. Thus, the invention provides a strain of *V. harveyi* that is genotypically luxN⁻ and luxS⁻. The new strain, designated MM32, is useful for identifying inhibitors of the quorum sensing pathway. For example, since the new strain is sensor 1⁻, its growth or ability to luminesce will not be affected by those organisms producing AI-1. Further, since MM32 is defective for production of AI-2, the addition of exogenous AI-2, or analogs thereof, allows for the rapid identification of modulators (activators or inhibitors) of AI-2.

[0160] In addition, the materials described above are ideally suited for the preparation of a kit. Such a kit may comprise a carrier means being compartmentalized to receive in close confinement one or more container means such as vials, tubes, and the like, each of the container means comprising one of the separate elements to be used in the method.

[0161] The container means may comprise a strain of bacteria capable of detecting the presence of an autoinducer. Preferably, the bacterial strain will be capable of providing an easily detectable signal in the presence of autoinducer-2. More preferably, the desired strain is defective in its ability to detect AI-1 (sensor 1⁻) and defective in its ability to synthesize AI-2. Thus, the kit may provide a strain of *V. harveyi* that is genotypically luxN⁻ and luxS⁻ designated MM32. The bacterial strain is useful for identifying autoinducer-2 as well as modulators (activators and inhibitors) of autoinducer-2 and the quorum sensing pathway.

V. Methods for Detecting a Bacterial Biomarker

[0162] Many bacteria presently known to utilize the autoinducer-1 signaling factor associate with higher organisms, *i.e.*, plants and animals, at some point during their lifecycles. For example, *Pseudomonas aeruginosa* is an opportunistic pathogen in humans with cystic fibrosis. *P.aeruginosa* regulates various virulence determinants with AI. Other examples of AI producing bacteria include *Erwinia carotovora*, *Pseudomonas aureofaciens*, *Yersinia enterocolitica*, *Vibrio harveyi*, and *Agrobacterium tumefaciens*. *E. carotovora* infects certain plants and creates enzymes that degrade the plant's cell walls, resulting in what is called "soft rot disease." *Yersinia enterocolitica* is a bacterium which causes gastrointestinal disease in humans and has been reported to produce an autoinducer. *P.aureofaciens* associates with the roots of plants and produces antibiotics that block fungus growth in the roots. The antibiotic synthesis is under autoinducer control. The present invention provides novel autoinducer-2 and methods of using autoinducer-2. In contrast to autoinducer-1, autoinducer-2 is believed to be an intra-species as well as inter-species signaling factor. Autoinducer-2 is further believed to regulate the expression of pathogenic and virulence factors not regulated by autoinducer-1. Thus, the

present invention provides a method to identify and regulate the expression of bacterial biomarkers in, for example, pathogenic bacteria. Methods of the invention can be used to regulate the activity of bacterial pathogens that are present in both plants and animals.

[0163] The invention further provides a method for detecting an autoinducer-associated bacterial biomarker by contacting at least one bacterial cell with an autoinducer under conditions and for such time as to promote induction of a bacterial biomarker. As used herein, an "autoinducer-associated bacterial biomarker" is any bacterial cell component which is regulated, modified, enhanced, inhibited or induced in response to an autoinducer. A biomarker can be any bacterial cell component that is identifiable by known microscopical, histological or molecular biological techniques. Such biomarkers can be used, for example, to distinguish pathogenic from non-pathogenic bacteria. Such a biomarker can be, for example, present on a cell surface, and it can be a protein, a nucleic acid, a phosphorylation event or any molecular or morphological characteristic of a bacterial cell that is modified as a result of the bacterium being contacted with an autoinducer. Preferably, the autoinducer is autoinducer-2. The method of the invention is particularly useful for identifying a biomarker which is indicative of bacterial pathogenicity. As previously noted, autoinducers are extracellular signalling factors used by a variety of bacteria to regulate cellular functions in response to various environmental stimuli, including high population density. It is believed that pathogenic bacteria express a biomarker, such as an antigenic determinant, as a result of increased autoinducer concentration in the surrounding environment. Thus, the present invention provides a method for identifying a biomarker by contacting a bacterium with autoinducer-2 and assaying for the presence of the biomarker.

[0164] The method of the invention contemplates the use of a probe to identify a biomarker present in a bacterial cell. As used herein, a "probe" can be a nucleic acid, protein, small molecule or antibody useful for detecting a bacterial biomarker present in a sample. The probe can be used in a screening assay to identify a biomarker present in a sample after the sample has been contacted with, for example, an autoinducer. For example, a bacterial biomarker produced by a bacterium following contact with an autoinducer can be identified by contacting a sample containing the bacterium with a probe that binds to the biomarker. Such assays can be used to detect, prognose, diagnose, or monitor various conditions, diseases, and disorders, or monitor the treatment thereof. A probe can be detectably labeled such that the probe is detectable when bound to its target marker. Such means for detectably labeling a probe include a biotin-binding protein, such as avidin or streptavidin, bound to a reporter, such as an enzymatic, fluorescent, or radionuclide label. Other reporter means and labels are well known in the art.

[0165] In addition, the method of the invention can be used to analyze differential gene expression in a bacterial cell following contact with an autoinducer. For example, where the expression of genes in different cells, normally a cell of interest and a control, is compared and any discrepancies in expression are identified. In such assays, the presence of discrepancies indicates a difference in the

classes of genes expressed in the cells being compared. Methods that can be used to carry out the foregoing are commonly known in the art.

[0166] The present invention provides a method for identifying a biomarker which can be a protein. For example, a bacterial protein expressed in response to an autoinducer can be detected using the appropriate antibody. The expressed protein can be, for example, an antigenic determinant indicative of a pathogenic bacterium. Antibodies used in the method of the invention are suited for use, for example, in immunoassays for the detection of such a determinant. The term "antibody" as used herein is meant to include intact polyclonal or monoclonal antibodies, as well as fragments thereof, such as Fab and F(ab')₂. For example, monoclonal antibodies are made from antigen containing fragments of a protein by methods well known to those skilled in the art (Kohler, *et al.*, *Nature*, 256:495, 1975).

[0167] In addition, the monoclonal antibodies in these immunoassays can be detectably labeled in various ways. For example, radioisotopes may be bound to an immunoglobulin either directly or indirectly by using an intermediate functional group. Intermediate functional groups which often are used to bind radioisotopes which exist as metallic ions to immunoglobulins are the bifunctional chelating agents such as diethylenetriamine-pentacetic acid (DTPA) and ethylenediaminetetraacetic acid (EDTA) and similar compounds. Typical examples of metallic ions which can be bound to monoclonal antibodies are ¹¹¹In, ⁹⁷Ru, ⁶⁷Ga, ⁶⁸Ga, ⁷²As, ⁸⁹Zr, and ²⁰¹Tl.

[0168] A probe useful in the method of the invention can also be a nucleic acid probe. For example, nucleic acid hybridization techniques are well known in the art and can be used to identify an RNA or DNA biomarker present in a sample containing a bacterium contacted with an autoinducer. Screening procedures which rely on nucleic acid hybridization make it possible to identify a biomarker from any sample, provided the appropriate probe is available. For example, oligonucleotide probes, which can correspond to a part of the sequence encoding a target protein, can be synthesized chemically. The DNA sequence encoding the protein can be deduced from the genetic code, however, the degeneracy of the code must be taken into account. For such screening, hybridization is preferably performed under *in vitro* or *in vivo* conditions known to those skilled in the art.

[0169] In addition, the materials described above are ideally suited for the preparation of a kit. Such a kit may comprise a carrier means being compartmentalized to receive in close confinement one or more container means such as vials, tubes, and the like, each of the container means comprising one of the separate elements to be used in the method. A kit of the invention may contain a first container means comprising isolated autoinducer-2. The isolated autoinducer-2 can be used to regulate the expression of a biomarker in a target bacterium. For example, autoinducer-2 can be used to induce expression of a particular biomarker which can then be identified by a probe. Thus, the kit may contain a second container means comprising a probe that can be detectably labeled. The kit may also have a third container comprising a reporter-means, such as a biotin-binding protein, such as avidin or streptavidin, bound to a reporter, such as an enzymatic, fluorescent, or radionuclide label. Other reporter

means and labels are well known in the art. For example, the kit of the invention may provide reagents necessary to perform nucleic acid hybridization analysis as described herein or reagents necessary to detect antibody binding to a target.

[0170] The following description sets forth the general procedures involved in practicing this aspect of the present invention. To the extent that specific materials are mentioned, it is merely for purposes of illustration and is not intended to limit the invention. Unless otherwise specified, general cloning procedures, such as those set forth in Sambrook *et al.*, Molecular Cloning, Cold Spring Harbor Laboratory (1989) (hereinafter "Sambrook *et al.*") or Ausubel *et al.* (eds) Current Protocols in Molecular Biology, John Wiley & Sons (1998) (hereinafter "Ausubel *et al.*") are used.

EXAMPLE 1

Quorum Sensing in *Escherichia coli* and *Salmonella typhimurium*

[0171] There have been preliminary indications that *E. coli* senses cell density (Huisman *et al.*, *Science* 265: 537-539, 1994; Sitnikov *et al.*, *Proc. Natl. Acad. Sci. USA* 93: 336-341, 1996; Garcia-Lara *et al.*, *J. Bacteriol.* 178: 2742-2748, 1996). We took advantage of the reduced selectivity of the Signaling System 2 sensor in *V. harveyi* to develop a sensitive assay for detection of extracellular signal compounds produced by *E. coli* and *S. typhimurium*. Using this assay we could determine the conditions under which many strains of *E. coli* and *S. typhimurium* synthesize, secrete, and degrade a signaling substance that will interact with the *V. harveyi* System 2 detector.

MATERIALS AND METHODS

[0172] Preparation of cell-free culture fluids. *E. coli* strains AB1157 and DH5 and *S. typhimurium* strain LT2 were grown at 30°C overnight with aeration in LB broth containing glucose at the concentrations specified in the text. The following morning fresh LB medium containing the same concentration of glucose used for the overnight growth was inoculated at a 1:100 dilution with the overnight grown cultures. The fresh cultures were grown for various times at 30°C with aeration. Cell-free culture fluids were prepared by removing the cells from the growth medium by centrifugation at 15,000 rpm for 5 min in a microcentrifuge. The cleared culture fluids were passed through 0.2 m HT Tuffryn filters (Gelman) and stored at -20°C. Cell-free culture fluids containing *V. harveyi* Autoinducer-2 were prepared from *V. harveyi* strain BB152 (Autoinducer 1⁻, Autoinducer 2⁺). *V. harveyi* BB120 (Autoinducer 1⁺, Autoinducer 2⁺) was used to prepare culture fluids containing Autoinducer-1. In both cases, the *V. harveyi* strains were grown overnight at 30°C with aeration in AB (Autoinducer Bioassay) (Bassler *et al.*, 1993, *supra*) medium. Cell-free culture fluids from *V. harveyi* were prepared from the overnight culture exactly as described above for *E. coli* and *S. typhimurium*.

[0173] Assay for production of signaling compounds. Cell-free culture fluids from *E. coli*, *S. typhimurium* and *V. harveyi* strains were tested for the presence of signaling substances that could induce luminescence in the *V. harveyi* reporter strain BB170 or BB886. In the assays, 10 l of cell-free culture fluids from *E. coli* AB1157, *E. coli* DH5, and *S. typhimurium* LT2 strains grown and harvested

as described above were added to 96-well microtiter dishes. The *V. harveyi* reporter strain BB170 or BB886 was grown for 16 h at 30°C with aeration in AB medium, diluted 1:5000 into fresh AB medium, and 90 l of the diluted cells were added to the wells containing the *E. coli* and *S. typhimurium* cell-free culture fluids. Positive control wells contained 10 l of cell-free culture fluid from strain *V. harveyi* BB152 (Autoinducer-1⁻, Autoinducer-2⁺) or *V. harveyi* BB120 (Autoinducer-1⁺, Autoinducer-2⁺). Negative control wells contained 10 l of sterile growth medium. The microtiter dishes were shaken in a rotary shaker at 175 rpm at 30°C. Every hour, light production was measured using a Wallac Model 1450 Microbeta Plus liquid scintillation counter in the chemiluminescence mode. The *V. harveyi* cell density was measured by diluting the same aliquots of cells used for measuring luminescence, spreading the dilutions onto solid LM medium (Bassler *et al.*, 1993, *supra*), incubating the plates overnight at 30C, and counting the resulting colonies the following day.

[0174] Preparation of *E. coli* and *S. typhimurium* viable and UV-killed cells for the activity assay. *E. coli* AB1157, *E. coli* DH5 and *S. typhimurium* LT2 cultures were grown for 8 h in LB containing 0.5% glucose at 30°C with aeration. The cultures were subjected to centrifugation for 5 min at 15,000 rpm in a microcentrifuge and the growth medium was removed from the cell pellets by aspiration. The cell pellets were resuspended in AB medium and washed by vigorous mixing. The cells were again subjected to centrifugation for 5 min at 15,000 rpm. The AB wash medium was removed and discarded and the cells were resuspended in fresh AB medium. Each cell suspension was diluted to give 1×10^6 cells/10 l, and multiple 10 l aliquots were added to wells of microtiter dishes. Half of the cell aliquots were treated with short wavelength ultraviolet light for 15 min at a distance of 10 cm. This treatment was sufficient to kill all of the cells as judged by plating and incubating the UV-treated cells, and ensuring that no growth occurred by the next day. 90 l of the diluted *V. harveyi* reporter strain BB170 was next added to the wells containing either the viable or dead *E. coli* and *S. typhimurium* cells, and the activity assay was carried out exactly as described in the previous section.

[0175] Analysis of glucose in *S. typhimurium* LT2 culture fluids. Glucose concentrations were determined in cell-free culture fluids prepared from *S. typhimurium* using a Trinder assay (Diagnostic Chemicals Ltd.) according to the recommendations of the manufacturer, except that the glucose standards were prepared in LB medium. The assay was sensitive to less than 0.002% glucose. No interfering substances were present in LB medium or spent LB culture fluids.

RESULTS AND DISCUSSION

[0176] *E. coli* AB1157 and *S. typhimurium* LT2 produce a signaling substance that specifically induces one of the two quorum sensing systems of *V. harveyi*. The *V. harveyi* reporter strain BB170 has the quorum sensing phenotype Sensor 1⁻, Sensor 2⁺. It induces *lux* expression in response to extracellular signals that act exclusively through the Signaling System 2 detector. Addition of 10% cell-free spent culture fluid prepared from *V. harveyi* strain BB152 (which contains the System 2 autoinducer) stimulates the reporter strain roughly 1000-fold over the endogenous level of luminescence expression.

In Figure 1, the light production by *V. harveyi* BB170 induced by the addition of 10% cell-free spent culture fluids is normalized to 100% activity.

[0177] *E. coli* strain AB1157 and *S. typhimurium* strain LT2 were grown for 8 h in LB broth or LB broth containing 0.5% glucose. The *E. coli* and *S. typhimurium* cells were removed from the growth medium and the cell-free culture fluids were prepared and assayed for an activity that could induce luminescence expression in *V. harveyi*. Addition of 10% cell-free culture fluid from *S. typhimurium* LT2 or *E. coli* AB1157 grown in LB containing glucose maximally induced luminescence in the reporter strain BB170, similar to culture fluids from *V. harveyi* BB152 (Fig. 1A). Specifically, *E. coli* AB1157 produced 106% and *S. typhimurium* produced 237% of the *V. harveyi* BB152 activity. When the *E. coli* and *S. typhimurium* were grown in LB without added glucose they did not produce the signaling factor. Substitution of 10% (v/v) of LB medium containing 0.5% glucose did not stimulate luminescence in the reporter strain, indicating that there is no substance in the LB-glucose growth medium that induces luminescence expression in *V. harveyi*. We tested obvious candidates for the signal including glucose, amino acids, cAMP, acetate, homoserine lactone, -ketoglutarate and other keto acids that are known to be excreted. None of these compounds has activity. These results suggest that *V. harveyi* BB170 can respond to some substance secreted by *E. coli* AB1157 and *S. typhimurium* LT2 when they are grown on LB containing glucose.

[0178] Analogous experiments were performed with the *V. harveyi* reporter strain BB886 (Sensor 1⁺, Sensor 2⁻). *V. harveyi* BB886 is defective in its response to signaling compounds that act through the Signaling System 2 detector, but it is an otherwise wild type strain (Bassler *et al.*, Mol. Microbiol. 13: 273-286, 1994). Fig. 1B shows the normalized 100% activation of *V. harveyi* BB886 by cell-free spent culture fluids prepared from *V. harveyi* BB120. *V. harveyi* BB120 produces the System 1 autoinducer *N*-(3-hydroxybutanoyl)-L-homoserine lactone (Bassler *et al.*, 1993, *supra*). Addition of *S. typhimurium* LT2 and *E. coli* AB1157 cell-free culture fluids to *V. harveyi* strain BB886 caused a 5% and a 1% increase above the control level (Fig. 1B). Together the results of Figure 1A and 1B show that the signaling compound produced by *E. coli* and *S. typhimurium* must act specifically through *V. harveyi* Signaling System 2 and not some other, unidentified pathway.

[0179] Viable *E. coli* AB1157 and *S. typhimurium* LT2 are required for secretion of the signaling compound. We considered the possibility that growth of *E. coli* AB1157 and *S. typhimurium* LT2 in LB medium containing glucose simply allowed them to utilize and therefore remove some pre-existing inhibitor of induction of luminescence. To show that the cells themselves produce the soluble signaling factor, we added washed *E. coli* and *S. typhimurium* cells directly to the luminescence assay. These results are presented in Figure 2. In this experiment, *E. coli* AB1157 and *S. typhimurium* LT2 were grown for 8 h in LB containing 0.5% glucose; the conditions for maximal production of the signaling factor. The cells were removed from the LB-glucose growth medium by centrifugation, and sterile *V. harveyi* luminescence assay medium was used to wash and resuspend the cell pellets. 1×10^6

E. coli AB1157 or *S. typhimurium* LT2 cells were added to the diluted *V. harveyi* BB170 culture at the start of the experiment. In Figure 2, the left-hand bar in each series shows that the presence of washed *E. coli* AB1157 or *S. typhimurium* LT2 cells is sufficient to fully induce luminescence in *V. harveyi* BB170. *E. coli* AB1157 and *S. typhimurium* LT2 stimulated *lux* expression in *V. harveyi* BB170 821-fold and 766-fold respectively. Identical aliquots of the washed *E. coli* or *S. typhimurium* cells were killed with short wave ultraviolet light prior to addition to the assay. When dead cells were included in the assay, no stimulation of luminescence occurred. In Figure 2, these results are shown in the right-hand bar for each strain. Taken together, the results show that the stimulatory factor is produced by the *E. coli* AB1157 and *S. typhimurium* LT2 cells themselves during the time course of the experiment; the factor could not have come from the medium in which the cells had been grown. This factor is actively released into the medium by *E. coli* and *S. typhimurium* because dead cells have no activity.

[0180] *E. coli* DH5 does not produce the signaling activity. Clinical isolates of *E. coli* and *Salmonella* also produce the signaling compound. Ten clinical isolates of *Salmonella* and five pathogenic isolates of *E. coli* O157 were assayed and all produced the activity. It was conceivable that the signal was some normal byproduct of glucose metabolism that simply diffuses out of the cells. This is not the case however, because we show that *E. coli* DH5, which is equally capable of utilizing glucose as *E. coli* AB1157 and *S. typhimurium* LT2, does not produce the signaling activity. Fig. 1A demonstrates that unlike *E. coli* AB1157 and *S. typhimurium* LT2, the addition of 10% cell-free culture fluid prepared from *E. coli* DH5 grown 8 h in LB containing 0.5% glucose does not stimulate light production in *V. harveyi* BB170. Similarly, inclusion of washed viable or killed *E. coli* DH5 cells in the luminescence assay does not stimulate *V. harveyi* BB170 to produce light (Figure 2). The inability of *E. coli* DH5 to produce the activity indicates that this highly domesticated strain lacks the gene or genes necessary for either the production or the export of the signaling activity. We assayed other laboratory strains of *E. coli* for the signaling activity (Table 1). Only *E. coli* DH5 was completely defective in producing the extracellular signal.

[0181] Table 1. The induction of luminescence in *V. harveyi* reporter strain BB170 by cell-free culture fluids from *V. harveyi*, *S. typhimurium* and *E. coli* is shown. Cell-free culture fluids were prepared from various strains of *V. harveyi*, *S. typhimurium* and *E. coli* as described and tested for production of a signaling substance that could stimulate light production in the reporter strain *V. harveyi* BB170. The level of *V. harveyi* stimulation was normalized to 100%. The data for the 5 h time point are shown.

Species and Strain	Induction of luminescence (%)
<i>V. harveyi</i> <i>V. harveyi</i> BB152	100
Salmonella <i>S. typhimurium</i> LT2	237
<i>E. coli</i> <i>E. coli</i> AB1157 <i>E. coli</i> DH5 <i>E. coli</i> JM109 <i>E. coli</i> MG1655 <i>E. coli</i> MC4100	106 5 76 100 93

[0182] Glucose regulates the production and degradation of the signaling factor by *S. typhimurium* LT2. Cell-free culture fluids from *S. typhimurium* LT2 and *E. coli* AB1157 cells grown in LB without added glucose did not stimulate the expression of luminescence in the reporter strain, indicating that metabolism of glucose is necessary for the production of the signal. We tested other carbohydrates, and in general, growth in the presence of PTS sugars (see Postma *et al.*, in *Escherichia coli and Salmonella Cellular and Molecular Biology*, (F.C. Niehardt, ed), Am. Soc. Microbiol., Washington D.C., pp. 1149-1174, 1996) enabled *E. coli* AB1157 and *S. typhimurium* LT2 to produce the signal. Of the sugars tested, growth on glucose induced the synthesis of the highest level of activity. Growth on other carbon sources, for example TCA cycle intermediates and glycerol, did not induce significant production of the signaling activity.

[0183] We tested whether the presence of glucose was required for the cells to continue to produce the signal. Figure 3 shows results with *S. typhimurium* LT2 grown in LB containing limiting (0.1%) and non-limiting (0.5%) glucose concentrations. Fig. 3A shows that when glucose is limiting, *S. typhimurium* LT2 produces the signal in mid-exponential phase (after 4 h growth), but stops producing the signaling activity once glucose is depleted from the medium. Fig. 3B shows that when glucose does not become limiting, *S. typhimurium* LT2 produces greater total activity and continues to produce the signaling activity throughout exponential phase, with maximal activity at 6 h growth. Furthermore, the Figure also shows that the signaling activity synthesized by mid-exponential phase cells is degraded by the time the cells reach stationary phase. In conditions of limiting glucose, no activity remained at stationary phase, and when glucose was plentiful, only 24% of the activity remained. Increasing the concentration of glucose in the growth medium did not change these results, *i.e.*, the activity was secreted during mid-exponential growth and severely reduced activity remained in the spent culture fluids by stationary phase.

[0184] In sum, the results presented in this example show that *E. coli* and *S. typhimurium* produce a signaling substance that stimulates one specific quorum sensing system in *V. harveyi*. Many other bacteria have previously been assayed for such an activity, and only rarely were species identified that are positive for production of this factor (Bassler *et al.*, 1997, *supra*). Furthermore, as shown here, the *E. coli* and *S. typhimurium* signal is potent, these bacteria make activity equal to that of *V. harveyi*.

The degradation of the *E. coli* and *S. typhimurium* signal prior to stationary phase indicates that quorum sensing in these bacteria is tuned to low cell densities, suggesting that quorum sensing in *E. coli* and *S. typhimurium* is modulated so that the response to the signal does not persist into stationary phase. Additionally, quorum sensing in *E. coli* and *S. typhimurium* is influenced by several environmental factors. The production and the degradation of the signal are sensitive not only to growth phase but also to the metabolic activity of the cells. These results indicate that the quorum sensing signal in *E. coli* and *S. typhimurium* has two functions; it allows the cells to communicate to one another their growth phase and also the metabolic potential of the environment.

[0185] Understanding the regulation of quorum sensing in *E. coli* and *S. typhimurium* is important for understanding community structure and cell-cell interactions in pathogenesis. In the wild, pathogenic *E. coli* and *S. typhimurium* may never reach stationary phase because dispersion is critical. It is therefore appropriate that quorum sensing in *E. coli* and *S. typhimurium* should be functioning at low cell density. This situation is in contrast to that of *V. fischeri*, the luminescent marine symbiont, where the quorum sensing system is only operational at high cell densities; cell densities indicative of existence inside the specialized light organ of the host. The specific quorum sensing systems of *V. fischeri* and *E. coli* and *S. typhimurium* appear appropriately regulated for the niche in which each organism exists. In both cases, quorum sensing could be useful for communicating that the bacteria reside in the host, not free-living in the environment. Additional complexity exists in the *E. coli* and *S. typhimurium* systems because these bacteria channel both cell density information and metabolic cues into the quorum sensing circuit. Again, signals relaying information regarding the abundance of glucose or other metabolites could communicate to the bacteria that they should undergo the transition from a free-living mode to the mode of existence inside the host.

[0186] Under all the conditions we have tested, the signaling activity described in this example does not extract quantitatively into organic solvents and it does not bind to either a cation or anion exchange column. Preliminary characterization indicates that the signal is a small (less than 1000 MW) polar but apparently uncharged organic compound. The activity is acid stable and base labile, it is heat resistant to 80 but not 100°C. Purification of the *E. coli*, *S. typhimurium* and *V. harveyi* signal is described in greater detail in the following examples.

EXAMPLE 2

Regulation of Autoinducer Production in *Salmonella typhimurium*

[0187] In this example, the conditions under which *S. typhimurium* LT2 produces AI-2, the extracellular factor that stimulates *lux* expression in the *V. harveyi* Sensor 1⁻, Sensor 2⁺ reporter strain, are elucidated. Production of the signaling compound by *S. typhimurium* occurs during growth on preferred carbohydrates that, upon utilization by the bacteria, result in a decrease in the pH of the medium. Lowering the pH of the growth medium in the absence of a preferred carbon source induces limited production of the factor, indicating that the cells are influenced by both the changing pH and the

utilization of the carbon source. The signaling activity is degraded by the time the cells reach stationary phase, and protein synthesis is required for degradation of the activity. Osmotic shock following growth on an appropriate carbon source greatly increases the amount of activity present in the *S. typhimurium* culture fluids. This increased activity is apparently due to induction of synthesis of the autoinducer and repression of degradation of the activity. *E. coli* and *S. typhimurium* possess a protein called SdiA which is homologous to LuxR from *V. fischeri* (Wang *et al.*, EMBO J. 10: 3363-3372, 1991; Ahmer *et al.*, J. Bacteriol. 180: 1185-1193, 1998). SdiA is proposed to respond to an extracellular factor (Sitnikov *et al.*, Proc. Natl. Acad. Sci. USA 93: 336-341, 1996; Garcia-Lara *et al.*, J. Bacteriol. 178: 2742-2748, 1996), and it has been shown to control virulence factor production in *S. typhimurium* (Ahmer *et al.*, 1998, *supra*). The analysis set forth below shows that the AI-2 autoinducer signaling activity does not function through the SdiA pathway.

MATERIALS AND METHODS

[0188] Strains and Media. The bacterial strains used in this study and their genotypes and phenotypes are listed in Table 2.

Table 2. Bacterial strains; their genotypes and relevant phenotypes.

Strain	Genotype	Relevant Phenotype
<i>S. typhimurium</i> LT2		Wild type
<i>E. coli</i> O157		Wild type
<i>E. coli</i> MG1655	F, <i>ilvG</i> , <i>rfb-50</i>	Wild type
<i>E. coli</i> MC4100	(<i>lac</i>)U169, <i>araD139</i> , <i>rpsL</i> , <i>thi</i>	LacZ ⁺
<i>E. coli</i> DH5	<i>supE44</i> , <i>hsdR17</i> , <i>recA1</i> , <i>endA1</i> , <i>gyrA96</i> , <i>thi-1</i> , <i>relA1</i>	AI-2 ⁻
<i>V. harveyi</i> BB170	<i>luxN::Tn5</i>	Sensor 1 ⁻ , Sensor 2 ⁺
<i>V. harveyi</i> BB152	<i>luxL::Tn5</i>	AI-1 ⁻ , AI-2 ⁺
<i>V. harveyi</i> JAF305	<i>luxN::Cm^r</i>	Sensor 1 ⁻ , Sensor 2 ⁺

[0189] Luria broth (LB) contained 10 g Bacto Tryptone (Difco), 5 g Yeast Extract (Difco) and 10 g NaCl per liter (Sambrook *et al.*, 1989). The recipe for Autoinducer Bioassay (AB) medium has been reported previously (Greenberg *et al.*, Arch. Microbiol. 120: 87-91, 1979). LM medium (L-Marine) contains 20 g NaCl, 10 g Bacto Tryptone, 5 g Bacto Yeast Extract and 15 g Agar per liter (Bassler *et al.*, 1994, *supra*). Regulation of AI-2 production similar to that reported here was also observed with the ATCC strain *Salmonella enterica* Serovar *Typhimurium* 14028, an independent clinical isolate of *Salmonella enterica* Serovar *Typhimurium*, and nine other *Salmonella enterica* serovars (other than *Typhimurium*).

[0190] Growth conditions for *S. typhimurium* LT2 and preparation of cell-free culture fluids. *S. typhimurium* LT2 was grown overnight in LB broth with shaking at 30°C. The next day, 30 l of the overnight culture was used to inoculate 3 ml of fresh LB broth. In cultures containing additional carbon sources, at the time of inoculation, 20% sterile stock solutions were added to give the specified final concentrations. Following subculturing of the cells, the tubes were shaken at 200 rpm at 30C for the time

periods indicated in the text. Cell-free culture fluids were prepared by removal of the cells from the culture medium by centrifugation for 5 min at 15,000 rpm in a microcentrifuge. The cleared supernatants were passed through 0.2 m cellulose acetate Spin X filters (CoStar, Cambridge, MA) by centrifugation for 1 min at 8000 X g. Samples were stored at -20°C. Similar results to those reported here were obtained when we grew the *S. typhimurium* at 37°C. The preparation of cell-free culture fluids from *V. harveyi* strains has already been reported (Bassler *et al.*, 1993, *supra*; Bassler *et al.*, 1997, *supra*).

[0191] Density-dependent bioluminescence assay. The *V. harveyi* reporter strain BB170 (Sensor 1⁻, Sensor 2⁺) (Bassler *et al.*, 1993, *supra*) was grown for 12 h at 30°C in AB medium, and diluted 1:5000 into fresh AB medium. Luminescence was measured as a function of cell density by quantitating light production at different times during growth with a Wallac Model 1409 liquid scintillation counter (Wallac Inc., Gaithersburg, MD). The cell density was measured by diluting the same aliquots of cells used for measuring luminescence, spreading the dilutions onto solid LM medium, incubating the plates overnight at 30°C, and counting the resulting colonies the following day. Relative Light Units are (counts min⁻¹ ml⁻¹ X 10³)/(colony forming units ml⁻¹). Cell-free culture supernatants from *V. harveyi* or *S. typhimurium* strains were added to a final concentration of 10% (v/v) at the time of the first measurement. In control experiments, 10% (v/v) of AB medium, LB medium or LB medium containing 0.5% glucose was added instead of cell-free culture fluids.

[0192] *S. typhimurium* autoinducer activity assay. The quorum sensing signaling activity released by *S. typhimurium* LT2 was assayed following growth under various conditions. 10 l of cell-free culture fluids from *S. typhimurium* LT2 grown and harvested as described above were added to 96-well microtiter dishes. The *V. harveyi* reporter strain BB170 was grown overnight and diluted as described above. 90 l of the diluted *V. harveyi* cells were added to the wells containing the *S. typhimurium* cell-free culture fluids. Positive control wells contained 10 l of cell-free culture fluid from *V. harveyi* BB152 (AI-1⁻, AI-2⁺) (Bassler *et al.*, 1993, *supra*). The microtiter dishes were shaken in a rotary shaker at 200 rpm at 30°C. Light production was measured hourly using a Wallac Model 1450 Microbeta Plus liquid scintillation counter designed for microtiter dishes (Wallac Inc., Gaithersburg, MD). In these experiments, the cell density was not measured at each time point. Rather, to ensure that increased light production was due to a signaling activity and not a growth medium component, the luminescence production by *V. harveyi* in wells containing cell-free culture fluids was compared to that produced by *V. harveyi* in wells containing 10 l of the identical growth medium alone. Data are reported as fold-stimulation over that obtained for growth medium alone.

[0193] Factors controlling signal production in *S. typhimurium*. *S. typhimurium* LT2 was grown for 6 h in LB containing 0.5% glucose as described above. The mid-exponential phase culture was divided into several identical aliquots. One aliquot of cells was grown to stationary phase (24 h at 30°C with shaking). In the remaining aliquots, the cells were removed from the LB-glucose growth medium by centrifugation for 5 min at 15,000 rpm in a microcentrifuge. The resulting cell pellets were

resuspended at an OD₆₀₀ of 2.0 in either LB, LB + 0.5% glucose, LB at pH 5.0, or in 0.1 M NaCl, or 0.4 M NaCl (in water). The resuspended cells were shaken at 30°C or 43°C for 2 h. Cell-free fluids were prepared from the stationary phase culture, and from the cells that had been resuspended and incubated in the various media or the osmotic shock solutions. The cell-free fluids were tested for signaling activity in the *S. typhimurium* activity assay as described above.

[0194] Effects of growth phase, pH, glucose concentration and osmolarity on autoinducer production by *S. typhimurium*. *S. typhimurium* LT2 was grown at 30°C for various times in LB containing limiting (0.1%) and non-limiting (1.0%) glucose concentrations. At the times specified in the text, the cell number was determined by plating dilutions of the *S. typhimurium* cultures onto LB medium and counting colonies the following day. The pH of the two cultures was measured, and the percent glucose remaining in each culture was determined using the Trinder assay as described in Example 1. Cell-free culture fluids were prepared from the LB-glucose cultures as described above. The same cells from which the cell-free culture fluids were prepared were resuspended in 0.4 M NaCl osmotic shock solution and shaken at 200 rpm, 30°C for 2 h. We determined that this timing was optimal for production of autoinducer. The cells were removed from the osmotic shock solution by centrifugation at 15,000 rpm for 5 min in a microcentrifuge. Cell-free osmotic shock fluids were prepared from the resuspended cells exactly as described for cell-free culture fluids. Signaling activity in both the cell-free culture fluids and the cell-free osmotic shock fluids was assayed as described above. In experiments in which the pH was maintained at 7.2, the cells were grown in LB + 0.5% glucose containing 50 mM MOPS at pH 7.2. The pH was adjusted every 15-30 min using 1 M MOPS pH 7.2. In experiments performed at pH 5.0, LB broth was maintained between pH 5.0 and 5.2 with 1M NaOH.

[0195] Requirement for protein synthesis in signal production, release and degradation by *S. typhimurium* LT2. *S. typhimurium* LT2 was pre-grown in LB containing 0.5% glucose at 30°C to an OD₆₀₀ of 2.5 (approximately 6-8 h). The culture was divided into four identical aliquots. Two aliquots were treated with 100 g/ml Cm for 5 min at room temperature after which the cells were harvested by centrifugation at 15,000 rpm for 5 min. One Cm-treated cell pellet was resuspended in 0.1 M NaCl containing 30 g/ml Cm, and the second pellet was resuspended in 0.4 M NaCl containing 30 g/ml Cm. Each of these pellets was resuspended to a final OD₆₀₀ of 2.0. The remaining two culture aliquots were not treated with Cm. Instead, the cells in these two aliquots were harvested by centrifugation and resuspended in 0.1 M and 0.4 M NaCl exactly as described for the Cm-treated cells. The cell suspensions were incubated at 30°C with shaking. At the times indicated in the text, 1.5 ml aliquots were removed from the cell suspensions and cell-free osmotic shock fluids were prepared by the procedure described above.

[0196] Analysis of the effect of autoinducer on SdiA regulated gene expression. A sequence that includes the ftsQ1p and ftsQ2p promoters (Wang *et al.*, 1991, *supra*) was amplified from *E. coli* MG1655 chromosomal DNA using the following primers:

ftsQ1p, 5'-CGGAGATCTGCGTTTCAATGGATAAACTACG-3' (SEQ ID NO: 19);

ftsQ2p, 5'-CGCGGATCCTTCTTTCGCTGTTTCGCGTG-3' (SEQ ID NO: 20).

The amplified product contained both the ftsQ promoters and the first 14 codons of the ftsQ gene flanked by BamHI and BglII sites. The ftsQ1p2p PCR product was cloned into the BamHI site of vector pMLB1034 (Silhavy *et al.*, Experiments with Gene Fusions, Cold Spring Harbor Press, 1984) to generate a lacZ fusion that contained the promoters, ribosome binding site, and initiation codon of ftsQ. A correctly oriented clone, pMS207, and a clone containing the ftsQ1p2p insert in the opposite orientation, pMS209, were chosen for further analysis. Both inserts were sequenced to ensure that no errors were introduced during the PCR reaction.

[0197] For *ftsQ* regulation in *E. coli*, the plasmids pMS207 and pMS209 were transformed into *E. coli* strain MC4100 (Silhavy *et al.*, 1984, *supra*), and the transformants were grown overnight in LB containing 100 mg/L ampicillin at 30°C with aeration. For *rck* regulation, *S. typhimurium* strains BA1105 (*rck::MudJ*) and BA1305 (*rck::MudJ sdiA*) were grown overnight in LB containing 100 mg/L kanamycin at 30°C with aeration. The overnight cultures were diluted 20-fold into fresh medium and grown for an additional 4.5 h. At this time, each culture was divided into five identical aliquots and 10% (v/v) of one of the following was added to each aliquot: LB, 0.4 M NaCl, 0.4 M osmotic shock fluids from *S. typhimurium* LT2, *E. coli* O157 or *E. coli* strain DH5 (negative control). The osmotic shock fluids were prepared as described above, following pre-growth of the *S. typhimurium* LT2 and *E. coli* in LB containing 0.5% glucose for 6h. The cell suspensions were incubated at 30°C for 2 h, after which standard -galactosidase reactions were performed on the samples (Miller, A Short Course in Bacterial Genetics, Cold Spring Harbor Laboratory Press, 1992).

RESULTS

[0198] *S. typhimurium* LT2 produces an autoinducer-like activity. In Example 1 it was demonstrated that *S. typhimurium* and *E. coli* strains produce a signaling activity that stimulates *lux* expression in *V. harveyi*, and the signaling compound acts exclusively through the *V. harveyi* quorum sensing System 2. Figure 4 shows the induction of luminescence in the *V. harveyi* System 2 reporter strain BB170 (Sensor 1⁻, Sensor 2⁺). The characteristic quorum sensing behavior of *V. harveyi* is shown in the control experiment (closed circles). Immediately after dilution into fresh medium, the light emitted per cell by *V. harveyi* drops rapidly, over 1000-fold. At a critical cell density, which corresponds to the accumulation of a critical concentration of endogenously produced autoinducer (AI-2) in the medium, the luminescence per cell increases exponentially, approximately 3 orders of magnitude, to again reach the pre-dilution level.

[0199] Addition of 10% cell-free culture fluid prepared from *V. harveyi* BB152 (AI-1⁻, AI-2⁺) caused the reporter strain to maintain a high level of light output following dilution (open circles). The increased light output is due to the *V. harveyi* BB170 cells responding to the presence of AI-2 in the cell-free culture fluids prepared from *V. harveyi* strain BB152 (Bassler *et al.*, 1993, *supra*). Similarly,

addition of cell-free culture fluid from *S. typhimurium* LT2 grown in LB + 0.5% glucose induced luminescence in the reporter strain approximately 800-fold over the control level (solid squares). No activity similar to *V. harveyi* AI-1 was produced by *S. typhimurium* LT2 under these conditions and there is no AI-1 or AI-2 activity in LB + 0.5% glucose (see Example 1).

[0200] Environmental factors influence autoinducer production and degradation in *S. typhimurium*. Control of autoinducer production in *S. typhimurium* is different than in other described quorum sensing systems. Fig. 5A demonstrates three important aspects of the regulation of autoinducer production in *S. typhimurium*. First, no autoinducer activity is observed when *S. typhimurium* is grown for 6 h in LB in the absence of glucose. Second, growth in the presence of glucose for 6 h results in substantial production of autoinducer (760-fold activation of the reporter strain). Third, activity, while detectable, is severely reduced when the *S. typhimurium* culture is allowed to grow to stationary phase (33-fold activation of the reporter strain).

[0201] We subjected *S. typhimurium* LT2 to several different treatments including some environmental stresses in order to begin to understand what conditions favor autoinducer production versus those that favor autoinducer degradation. In the experiment presented in Fig. 5B, the *S. typhimurium* cells were induced for signal production by pre-growth in LB containing 0.5% glucose for 6 h. We have shown that under these conditions, the glucose is not depleted (Surette and Bassler, 1998). After the induction phase of growth, the culture fluid was removed and aliquots of the cells were resuspended and incubated for 2 h under a variety of conditions that are described in the description of Figure 2. Following each of these treatments cell-free fluids were prepared and tested for activity on BB170.

[0202] It is important to note that in the results presented in Fig. 5B, the *S. typhimurium* were pre-induced for autoinducer production at the start of the experiment, *i.e.*, their cell-free culture fluid activated the reporter strain 760-fold. Fig. 5B shows that removal of the pre-growth culture fluid from these cells and resuspension of the cells in LB without glucose, in 0.1 M NaCl (hypotonic conditions), or heat shock at 43°C for 2 h resulted in no or very low autoinducer production. These results indicate that the above treatments result in termination of autoinducer production, or degradation of newly released autoinducer, or both.

[0203] In contrast to the above results, resuspension of pre-induced cells in fresh LB + glucose resulted in continued high-level production of autoinducer (735-fold activation of the reporter). Similarly, acidic pH promoted continued production of autoinducer (600-fold activation), and hypertonic osmotic shock (0.4 M NaCl) resulted in 1300-fold induction of the reporter. Increased AI-2 activity was only observed in the pH 5.0 fluids or 0.4 M NaCl osmotic shock fluids of cells that were already actively producing AI-2, *i.e.*, if glucose was not included during the pre-growth, no measurable activity was produced following the identical 2 h treatments.

[0204] Shifting *S. typhimurium* cells from LB + glucose to 0.4 M NaCl resulted in an accumulation of AI-2 activity to a level much greater than that observed under any other condition tested. Below it is shown that *S. typhimurium* cells resuspended in 0.4 M NaCl increase the biosynthesis and/or release of autoinducer, and furthermore they apparently do not degrade significant quantities of the released activity. A similar increase in AI-2 production occurs when the *S. typhimurium* cells are resuspended in 0.4 M NaCl, 0.4 M KCl or 0.8M sucrose, indicating that the NaCl effect on AI-2 production is an osmotic one, not an ionic one. This apparent osmotic shock effect on the *S. typhimurium* cells was extremely useful because it enabled us to measure maximal release of autoinducer activity in the absence of loss due to degradation.

[0205] The effect of glucose on signal production in *S. typhimurium*. In Example 1 we showed that the continued presence of glucose was required for *S. typhimurium* to produce the quorum sensing signaling factor. Because sugar utilization both increases the growth rate while decreasing the pH of the culture, we further analyzed the effect of metabolism of glucose, decreasing pH and increasing cell number on signal production by *S. typhimurium*. In the experiment presented in Figure 6, we measured signal production, growth rate, and pH in growing *S. typhimurium* LT2 cultures containing limiting (0.1%) and non-limiting (1.0%) concentrations of glucose. In the data presented in Figure 6, at various times, the level of autoinducer produced in both the cell-free culture fluids and in the corresponding 0.4 M NaCl osmotic shock fluids was measured and normalized for 1×10^9 cells. It should be noted that unlike in Figure 5, the cells in this experiment were not pre-induced for signal production.

[0206] Figure 6 shows that the pattern of production and disappearance of autoinducer observed in 0.4 M NaCl osmotic shock fluids mimics that observed in cell-free culture fluids. However, at every time point that autoinducer is produced, much greater activity is detected in the osmotic shock fluids than in the corresponding cell-free culture fluids. Under conditions of limiting (0.1%) glucose (Figs. 6A, 6C and 6E), *S. typhimurium* produces the signaling activity between 2-4 h (Bars). However, the glucose becomes completely depleted at 4 h, and at that time production of the factor ceases (Fig. 6A). In contrast, when the cells are grown in 1.0% glucose (Figs. 6B, 6D, and 6F), glucose is present in the medium throughout the entire experiment (Fig. 6B). Under these conditions, the cells continue to synthesize activity for 12 hours. Similar to the results shown in Figure 5 and those reported in Example 1, almost no activity was observed in cell-free culture fluids or osmotic shock fluids from stationary phase cells at 24 h regardless of the glucose concentration.

[0207] *S. typhimurium* grows at roughly the same rate in both high and low glucose media during exponential phase. In fact, the *S. typhimurium* culture grown in high glucose medium does not reach the cell density achieved by the *S. typhimurium* grown in the low glucose medium (Figs. 6C and 6D). Cell growth is probably inhibited in this culture by the dramatically reduced pH that occurs from increased glucose utilization. These results show that the higher level of activity produced by *S.*

typhimurium in the LB containing 1% glucose is not due to higher cell number, but due to induction of signal production caused by glucose metabolism.

[0208] Figs. 6E and 6F show the pH of the low and high glucose cultures at each time point. Under conditions of low glucose (Fig. 6E), the pH of the culture initially decreases as the cells utilize the glucose. However, simultaneous to the complete depletion of the glucose, the pH begins to rise. In contrast, under conditions of high glucose, the pH of the medium decreases to below pH 5 (Fig. 6F). In the experiments presented in Figure 6, both glucose catabolism and decreasing pH occur simultaneously suggesting that either or both of these factors could be responsible for signal production by *S. typhimurium*.

[0209] Both glucose metabolism and low pH independently control signal production in *S. typhimurium*. To distinguish between the contribution from glucose metabolism and that from low pH in signal production by *S. typhimurium*, we compared the activity produced by *S. typhimurium* grown in LB containing 0.5% glucose in a culture in which the pH was maintained at 7.2 (Fig. 7A), to that produced by *S. typhimurium* grown in LB without glucose where the pH was maintained at 5.0 (Fig. 7B). Again, we measured the signal present in cell-free culture fluids and in 0.4 M NaCl osmotic shock fluids. Similar to the data presented in Figure 3, the level of signal observed in cell-free culture fluids was lower than that observed in the 0.4 M osmotic shock fluids.

[0210] When *S. typhimurium* was grown in LB + 0.5% glucose at pH 7.2 increasing amounts of the quorum sensing signal were detected for 6 h. At 6 h, in 0.4 M NaCl osmotic shock fluids, there was an approximately 550-fold stimulation of light production of the *V. harveyi* reporter strain BB170. No activity was produced after the 6 h time point. Fig. 7A shows that the pH was maintained between 7.15 and 7.25 for 8 h, after this time, the pH of the culture no longer decreased, but began increasing presumably because the cells had depleted the glucose. We allowed the pH to continue to increase for the duration of the experiment. Also shown in the Figure is the cell number at each time point. At pH 7.2, the cells grew rapidly and reached a high cell density.

[0211] Analysis of time courses similar to those presented here, has shown that *S. typhimurium* does not produce any signal when it is grown in LB without glucose at neutral pH (see Example 1). However, *S. typhimurium* did transiently produce the quorum sensing factor in the absence of glucose when grown at pH 5.0 (Fig. 7B). Signal was produced for 4 h, and about 450-fold stimulation of the reporter was the maximum activity achieved in 0.4 M NaCl osmotic shock fluids. Very little signal was produced by 5 h, and signal was completely absent after 6 h of incubation. Fig. 7B shows that the pH was maintained between 5.0 and 5.2 in this experiment. Note that the cells grew much more slowly at pH 5.0 than at pH 7.2.

[0212] Preliminary characterization of the *S. typhimurium* autoinducer degradative apparatus. The quorum sensing activity produced by *S. typhimurium* LT2 is degraded by the onset of stationary phase. We have determined that the activity contained in cell-free culture supernatants and 0.4 M NaCl

osmotic shock fluids from cells grown for 6 h in LB + glucose is stable for at least 24 h at 30°C, indicating that no degradative activity is present in these cell-free fluids. Furthermore, mixing cell-free culture fluids prepared from actively producing *S. typhimurium* (i.e., from cultures grown for 6 h in LB + glucose) with cell-free culture fluids prepared from *S. typhimurium* that have degraded the factor (i.e., from cultures grown for 12 or 24 h in LB + glucose) does not result in degradation of the activity. This result indicates that the degradative activity is not released, but instead, is associated with the cells.

[0213] We show in Figure 5 that no further autoinducer is produced if *S. typhimurium* cells that are actively releasing autoinducer are shifted to 0.1 M NaCl. However, when these same cells are shifted to 0.4 M NaCl, we observe even greater autoinducer production. This result implies that low osmolarity could be a signal that induces the autoinducer degradative machinery. To begin to analyze the mechanism by which osmolarity affects autoinducer production and degradation in *S. typhimurium*, we investigated the requirement for protein synthesis in signal production and degradation by *S. typhimurium* in high and low osmolarity. As described in the legend to Figure 5, *S. typhimurium* LT2 was grown in LB containing 0.5% glucose to achieve maximal induction of signal production then treated with 0.1 M or 0.4 M NaCl in the presence and absence of protein synthesis. Cell-free fluids were prepared and tested for signaling activity. Because half of the cell-free osmotic shock fluids contained chloramphenicol (Cm), *V. harveyi* JAF305 was used as the reporter strain in the activity assay. This *V. harveyi* strain contains a Cm^r cassette in the *luxN* gene, and its phenotype is Sensor 1⁻, Sensor 2⁺, a phenotype identical to that of *V. harveyi* BB170.

[0214] When the cells were resuspended in 0.4 M NaCl, the *S. typhimurium* produced and released increasing amounts of the signal for 200 min (Fig. 8A, open squares). After this time, the level of signaling activity present in the cell-free osmotic shock fluid decreased somewhat, suggesting that some of the released signal was degraded. Quite different results were obtained when the *S. typhimurium* cells were resuspended in 0.1 M NaCl (Fig. 8B, open squares). In this case, at early time points, the *S. typhimurium* produced a quantity of activity equivalent to that produced by cells resuspended in 0.4 M NaCl. However, by 120 min, no activity remained in the cell-free low osmolarity fluid. This result indicates that under conditions of low osmolarity, the released activity is rapidly degraded. We do not observe degradation of the activity in cell-free culture fluids, indicating that the disappearance of the activity from low osmolarity cell-free fluids is not due to chemical instability of the signaling compound.

[0215] Under conditions of high osmolarity, when the cells were treated with Cm to inhibit protein synthesis, only about one quarter of the activity was produced compared to untreated cells. The closed squares in Fig. 8A show that 300-fold induction of the reporter strain occurred in the presence of Cm as compared to 1200-fold induction with the untreated cells (Fig. 8A, open squares). When the *S. typhimurium* was resuspended in low osmolarity (Fig. 8B), roughly three-quarters of the activity produced in the absence of Cm (open squares) was produced in the presence of Cm (closed squares).

In the presence of Cm, the released activity was not degraded by 300 min in high osmolarity and only partially degraded in low osmolarity.

[0216] To show that high osmolarity does not inhibit AI-2 signal degradation, we added the activity contained in the 0.4 M NaCl cell-free osmotic shock fluids to *S. typhimurium* cells that had been resuspended in 0.1 M NaCl for two hours. As shown in Figure 8, these are cells that can degrade the factor. Table 3 shows that these *S. typhimurium* cells degraded greater than 98% of the signaling activity while incubated at high osmolarity. The table also shows that *S. typhimurium* cells that had been incubated in 0.4 M NaCl (these are cells that are actively producing the signal) released no further activity when resuspended in the 0.1 M NaCl incubation fluid obtained from the actively degrading cells. Furthermore, mixing active and inactive 0.4 M and 0.1 M cell-free osmotic fluids did not result in degradation of the activity in the 0.4 M fluids.

Table 2. High osmolarity induces release and low osmolarity induces degradation of the *S. Typhimurium* signaling factor.

Treatment	Fold-induction of luminescence
0.1 M NaCl activity ^a	4
0.4 M NaCl activity ^a	944
0.1 M cells + 0.4 M activity ^b	17
0.4 M cells + 0.1 M activity ^c	6

^a *S. typhimurium* was grown for 6 h in LB containing 0.5% glucose. The cells were pelleted and resuspended in either 0.1 M or 0.4 M NaCl for 2 h. Cell-free fluids were prepared and tested for activity.

^b *S. typhimurium* cells that had been incubated in 0.1 M NaCl for two hours were pelleted and resuspended in the activity contained in the cleared osmotic shock fluids obtained from cells suspended in 0.4 M NaCl for 2 h. Cell-free fluids were prepared after a 2 h incubation and assayed for signaling activity.

^c *S. typhimurium* cells that had been suspended in 0.4 M NaCl were pelleted and incubated for 2 h in the cleared osmotic shock fluids obtained from cells suspended for 2 h in 0.1 M NaCl. Cell-free fluids were prepared after the 2 h incubation and assayed for signaling activity.

[0217] The LuxR homolog SdiA is not involved in response to the AI-2 autoinducer. A gene homologous to *luxR* of *V. fischeri* has been identified in *E. coli* and *S. typhimurium* and is called *sdiA*. Two reports suggest that in *E. coli*, SdiA modestly regulates the expression of the cell division locus *ftsQAZ* in response to a factor present in cell-free culture fluids (Garcia-Lara *et al.*, 1996, *supra*), and in response to a few homoserine lactone autoinducers (Sitnikov, *et al.*, 1996, *supra*). Completion of the sequence of the *E. coli* genome shows that no LuxI homologue exists in *E. coli* so the locus responsible for the biosynthesis of the hypothesized soluble factor(s) has not been determined. Overexpression of SdiA in *S. typhimurium* has recently been shown to influence the expression of several ORFs located on the *S. typhimurium* virulence plasmid (Ahmer, *et al.*, 1998, *supra*). As in the *E. coli* studies, SdiA activity in *S. typhimurium* is proposed to be modulated by an extracellular factor.

[0218] It was possible that the AI-2 autoinducer that we have been characterizing in *S. typhimurium* and *E. coli* acted through SdiA. We tested whether AI-2 had an effect on genes regulated by SdiA in *E. coli* and *S. typhimurium*. In *E. coli*, we assayed an *ftsQ1p2p-lacZ* reporter, and in *S. typhimurium* we assayed an *rck::MudJ* fusion in both an *sdiA*⁺ and *sdiA*⁻ background. We tested the effects of addition of LB, 0.4 M NaCl, 0.4 M NaCl osmotic shock fluids containing AI-2 activity from *S. typhimurium* LT2, *E. coli* O157, and 0.4 M NaCl osmotic shock fluid from *E. coli* DH5. We have shown previously in Example 1 that DH5 does not produce AI-2 activity under our growth conditions.

[0219] For the *E. coli* experiments we determined that MC4100 and MC4100/pMS209 (containing *ftsQ1p2p* in the incorrect orientation) had no measurable -galactosidase activity. The level of -galactosidase produced by MC4100/pMS207 (containing the *ftsQ1p2p-lacZ* fusion) was roughly 20-30 Miller units, and this level of activity did not change under any of the conditions tested here. This level of activity of the fusion was comparable to that reported previously (Sitnikov *et al.*, 1996, *supra*; Garcia-Lara *et al.*, 1996, *supra*). In the *S. typhimurium* SdiA studies, similar to Ahmer *et al.* (1998, *supra*), we obtained ~30 Miller units of *rck::MudJ* activity in the *sdiA*⁺ background and this level was reduced to 10 units in the *sdiA*⁻ background. No change in -galactosidase production occurred following the addition of AI-2 from *E. coli* or *S. typhimurium*. These results indicate that, if an extracellular factor exists that modulates the activity of SdiA, under the conditions we have tested, it is not AI-2.

DISCUSSION

[0220] Quorum Sensing in *E. coli* and *S. typhimurium*. We have developed a heterologous bioassay that enables us to detect an extracellular signaling factor produced by *S. typhimurium*. The factor mimics the action of AI-2 of the quorum sensing bacterium *V. harveyi*, and it acts specifically through the *V. harveyi* Signaling System 2 detector LuxQ. Results using *lacZ* fusions to the *ftsQ* and *rck* promoters indicate that, under our assay conditions, the AI-2 quorum sensing factor does not signal to SdiA, at least with respect to regulation of these genes. The AI-2 quorum sensing system is therefore involved in a different *S. typhimurium* and *E. coli* signal transduction pathway than the one(s) investigated previously.

[0221] *S. typhimurium* LT2 produces an amount of activity roughly equivalent to that produced by *V. harveyi*. We observe approximately 800-fold stimulation of the *V. harveyi* reporter strain BB170 upon addition of 10% *S. typhimurium* cell-free culture fluids. The timing of *lux* induction and the shape of the response curve of *V. harveyi* to the *S. typhimurium* signal are indistinguishable from those of *V. harveyi* responding to its own AI-2. Furthermore, we have been successful at partially purifying both the *V. harveyi* AI-2 and the *S. typhimurium* signal compound using identical purification procedures. These two results lead us to believe that the *S. typhimurium* signaling compound is identical to or very closely related to AI-2 of *V. harveyi*.

[0222] Growth Conditions Regulate Signal Production and Degradation in *S. typhimurium*. In this example, we further characterize the regulation of the signaling activity in *S. typhimurium* LT2.

Accumulation of signaling activity in *S. typhimurium* culture supernatants is maximal during mid-exponential phase when the cells are actively utilizing glucose in rich medium. Under these growth conditions, utilization of glucose is accompanied by a rapid drop in pH of the culture. The results demonstrate that either glucose metabolism or low pH is sufficient to induce *S. typhimurium* LT2 to produce the quorum sensing factor, indicating that both glucose and acidity generate independent signals for autoinducer production. In the presence of glucose, when the pH is not maintained, probably both the decreasing pH and the presence of an appropriate carbon source contribute to the regulation of quorum sensing in *S. typhimurium*. The results also show that production of the autoinducer ceases prior to stationary phase in the presence of glucose at neutral pH and in the absence of glucose at low pH. Therefore, a combination of acidic conditions and the absence of glucose is not required to cue *S. typhimurium* to terminate production of autoinducer.

[0223] In addition to glucose, growth on several other carbohydrates also induces production of the signaling activity. These include both PTS (fructose, mannose, glucitol, and glucosamine) and non-PTS (galactose and arabinose) sugars. These findings eliminate an exclusive role for the PTS in the regulation of autoinducer biosynthesis. When the *S. typhimurium* LT2 are grown on several other carbon sources (acetate, glycerol, citrate and serine) no significant accumulation of signaling activity is observed. We have demonstrated in Example 1 that the signal is not any of a number of substances known to be secreted by *S. typhimurium* including the major products of mixed acid fermentation. Clearly, production of the signaling compound is precisely regulated by the cells and is favored under conditions of growth on preferred carbohydrates for reasons that we do not yet understand. Identification of the signaling compound and cloning of the biosynthetic gene(s) will aid in a fuller understanding of the regulation process.

[0224] Results presented in this example show that, in contrast to other quorum sensing systems, the *S. typhimurium* signal does not accumulate in stationary phase. At least two competing processes contribute to this regulation; autoinducer production and autoinducer degradation. In this example we are defining autoinducer production as an increase in the signaling activity present in cell-free fluids. We recognize that an increase in activity could result from release of newly biosynthesized autoinducer, release of stored autoinducer, repression of degradation of autoinducer, or some combination of these activities. We define autoinducer degradation as the disappearance of signaling activity from the cell-free fluids. This disappearance could be due to destruction of the autoinducer, reuptake of the autoinducer, or a combination of these activities. It is possible that under some of the conditions used in our studies, autoinducer production and autoinducer degradation are occurring simultaneously. If this is the case, the activity detected in cell-free culture fluids is a measure of which of these processes, production or degradation, predominates. These findings indicate that quorum sensing in *S. typhimurium* is regulated such that the signal and presumably the response to the signal do not persist into stationary phase. Because the utilization of a preferred carbohydrate is also required for

signal production, quorum sensing in *S. typhimurium* may be used both for measuring the cell density and for measuring the potential of the environment for growth.

[0225] Osmolarity Influences Signal Production and Degradation in *S. typhimurium*. *S. typhimurium* cells that are actively producing signal can be further stimulated to produce signal by specific environmental treatments, indicating that several independent regulatory pathways channel information into autoinducer synthesis. One of these treatments is 0.4 M NaCl osmotic shock. When autoinducer producing *S. typhimurium* cells are resuspended in 0.4 M NaCl, the cells release significantly greater activity when they have the capability to synthesize protein than when protein synthesis is blocked. Furthermore, degradation of the signal also requires protein synthesis. These results have several implications. First, in the presence of Cm, *S. typhimurium* resuspended at both high and low osmolarity produce a similar amount of activity. This result indicates that, following growth in the presence of glucose, the *S. typhimurium* cells have a pre-defined capacity to produce signaling activity (and/or to release already synthesized activity from the cell). Second, when the cells are resuspended at high osmolarity, signal production increases well beyond this level. This increase in signal production requires protein synthesis, and we interpret this to mean that high osmolarity is one environmental cue that induces *S. typhimurium* to synthesize more of the biosynthetic apparatus necessary for signal production and/or release. Third, under conditions of low osmolarity, we observe an initial release of activity, followed by a rapid degradation of the activity. And, signal degradation requires protein synthesis because it is not observed in the presence of Cm. These results imply that the environment has changed from conditions favoring autoinducer production (LB + a preferred carbohydrate, or high osmolarity) to conditions where autoinducer production is not favored (low osmolarity, or absence of a preferred carbon source). This environmental change induces *S. typhimurium* to synthesize the protein(s) required for degradation of the signaling activity.

[0226] When the *S. typhimurium* cells were incubated in 0.4 M NaCl no significant degradation of the activity occurred by 200 min. This result indicates that either the necessary degradative protein(s) are not synthesized under these conditions, or alternatively, the degradative apparatus is assembled, but its activity is inhibited by high osmolarity. The results show that high osmolarity does not inhibit signal degradation, because cells induced to degrade the activity can do so at high osmolarity. Therefore, the persistence of the activity in the high NaCl samples occurs because the degradation machinery is not synthesized, not because its activity is inhibited.

[0227] It is difficult to precisely determine when *S. typhimurium* cells are autoinducer producers and when they are autoinducer degraders because both processes could occur simultaneously. It appears, however, that no or very low degradation occurs in high osmolarity, and conversion of cells from overall signal producers to overall signal degraders occurs in low osmolarity and requires protein synthesis. Our preliminary characterization of the degradative process indicates that it is cell-associated because the autoinducer activity is stable in cell-free culture supernatants for long periods of time, and

combining active with inactive cell-free culture fluids or active and inactive high and low osmolarity cell-free fluids does not promote degradation of the autoinducer. We have recently isolated a *S. typhimurium* mutant that does not produce the AI-2 activity. If this mutant retains the capability to degrade autoinducer, analysis of it will be informative for understanding the timing of degradation, and for identifying the cues that induce the degradative machinery. We are currently attempting to isolate *S. typhimurium* mutants capable of autoinducer production but incapable of autoinducer degradation.

[0228] The Role for Quorum Sensing in *Salmonella* Pathogenesis. The observations presented here on the regulation of signal production and degradation by *S. typhimurium* LT2 implicate a role for quorum sensing in pathogenesis of *Salmonella*. The conditions favoring signal production (nutrient rich, high osmolarity and low pH) are those likely to be encountered upon the first interaction of an enteric pathogen with its host. Conditions favoring degradation of the signal (nutrient poor, low osmolarity) are those most probably encountered as the pathogen exits the host. The initial colonization of the host may be a concerted effort between a population of cells coordinated through this cell-cell signaling system. Other cues, that we have not yet tested, could also regulate quorum sensing in *S. typhimurium*. These may represent independent or overlapping signaling pathways involved in pathogenesis. We are isolating *S. typhimurium* mutants to test these hypotheses. Finally, *Salmonella* pathogenesis is a dynamic process of interaction between the host and metabolically active bacteria. Consistent with a role for quorum sensing in pathogenesis, our evidence suggests that this quorum sensing system is not functioning during stationary phase. We have shown that the signaling compound is not produced during stationary phase, and furthermore, existing signal is degraded. Perhaps quorum sensing is critical for *S. typhimurium* to undergo the transition between a host-associated and a free-living existence.

EXAMPLE 3

Quorum Sensing in *Escherichia coli*, *Salmonella typhimurium* and *Vibrio harveyi*: A New Family of Genes Responsible for Autoinducer Production

[0229] In this example we report the analysis of a gene responsible for AI-2 production in *V. harveyi*, *E. coli* and *S. typhimurium*. The gene identified in all three species of bacteria is highly homologous, and we propose that these genes define a new family of proteins involved in autoinducer production. The genes, which we named *luxS_{V.h.}*, *luxS_{E.c.}*, and *luxS_{S.t.}* have been identified in many species of bacteria by genome sequencing projects, but until now no function has been ascribed to this gene in any organism. The *luxS* genes do not bear homology to any other gene known to be involved in autoinducer production.

MATERIALS AND METHODS

[0230] Bacterial strains, media and recombinant DNA techniques. *V. harveyi* BB120 is the wild type strain (Bassler *et al.*, 1997, *supra*). *S. typhimurium* strain LT2 was obtained from Dr. K. Hughes (University of Washington), *S. typhimurium* 14028 is ATCC strain 14028 Organism: *Salmonella choleraesuis*. *E. coli* O157:H7 is a clinical isolate supplied by Dr. Paddy Gibb (University of Calgary).

Luria broth (LB) contained 10 g Bacto Tryptone (Difco), 5 g Yeast Extract (Difco) and 10 g NaCl per liter. The recipe for Autoinducer Bioassay (AB) medium has been reported previously (Greenberg, E.P., Hastings, J.W., and Ulitzur, S. (1979) *Arch. Microbiol.* 120, 87-91). Where specified, glucose was added from a sterile 20% stock to a final concentration of 0.5%. Antibiotics were used at the following concentrations (mg/L): Ampicillin (Amp) 100, Chloramphenicol (Cm) 10, Gentamycin (Gn) 100, Kanamycin (Kn) 100, and Tetracycline (Tet) 10. DNA isolation, restriction analysis and transformation of *E. coli* was performed as described by Sambrook *et al.* Probes for Southern Blot analysis were labeled using the Multiprime DNA labeling system of Amersham. Sequencing was carried out using an Applied Biosystems sequencing apparatus. The *V. harveyi* BB120 genomic library was constructed in the cosmid pLAFR2 as described (Bassler *et al.*, 1993, *supra*). The method for Tn5 mutagenesis of cloned *V. harveyi* genes, and the allelic replacement technique for inserting Tn5 mutated genes into the *V. harveyi* chromosome have been reported (Bassler *et al.*, 1993, *supra*).

[0231] Bioluminescence Assay. The AI-2 bioassay using the *V. harveyi* reporter strain BB170 (Sensor 1⁻, Sensor 2⁺) has been discussed in the previous examples. Cell-free culture fluids from *V. harveyi*, *E. coli*, or *S. typhimurium* strains to be tested for AI-2 activity were prepared as described above, and assayed at 10% (v/v). AI-2 activity is reported as the fold-induction of the reporter strain over background, or as the percent of the activity obtained from *V. harveyi* BB120 (wild type) cell-free culture fluid.

[0232] Mutagenesis and analysis of the AI-2 production gene in *S. typhimurium* LT2. MudJ insertion mutants of *S. typhimurium* LT2 were generated using a phage P22 delivery system as described (Maloy, S.R., Stewart, V.J., and Taylor, R.K. (1996) *Genetic analysis of pathogenic bacteria: a laboratory manual*. Cold Spring Harbor Laboratory Press, Cold Spring Harbor, N.Y.). Following growth to mid-exponential phase in LB containing 0.5% glucose, the *S. typhimurium* insertion mutants were tested for AI-2 production using the *V. harveyi* BB170 bioassay. The site of the MudJ insertion that inactivated the AI-2 production function in *S. typhimurium* was identified by PCR amplification and sequencing of the chromosomal DNA at the insertion junction. A two-step amplification procedure was used (Caetano-Annoles, G. (1993) *Meth. Appl.* 3, 85-92). In the first PCR reaction, the arbitrary primer 5'-GGCCACGCGTCGACTAGTACNNNNNNNNNNACGCCC-3' (SEQ ID NO: 21), and the MudJ specific primer 5'-GCACTACAGGCTTGCAAGCCC-3' (SEQ ID NO: 22) were used. Next, 1 μl of this PCR reaction was used as the template in a second PCR amplification employing a second arbitrary primer (5'-GGCCACGCGTCGACTAGTCA-3') (SEQ ID NO: 23) and another MudJ specific primer (5'-TCTAATCCATCAGATCCCG-3') (SEQ ID NO: 24). The PCR product from the second reaction was purified and sequenced.

[0233] Cloning and sequencing of the *E. coli* MG1655, *E. coli* 0157:H7, and *E. coli* DH5 AI-2 production genes. The DNA sequence obtained from the *S. typhimurium* LT2 MudJ screen was used to search the *E. coli* MG1655 genome sequence to identify the corresponding *E. coli* region (Blattner

et al., Science 277, 1453-1462, 1997). The gene identified from the sequencing project had the designation *ygaG*. Primers that flanked the *ygaG* gene and incorporated restriction sites were designed and used to amplify the *E. coli* MG1655, *E. coli* 0157:H7 and *E. coli* DH5 *ygaG* genes. The primers used are: 5' -GTGAAGCTTGTCTTACTGACTAGATC-3' (SEQ ID NO: 25) and 5' -GTGTCTAGAAAAACACGCCTGACAG-3' (SEQ ID NO: 26). The PCR products were purified, digested and cloned into pUC19. In each case, the PCR products from three independent reactions were cloned and sequenced.

RESULTS

[0234] Identification and cloning of the gene responsible for AI-2 production in *V. harveyi*. We have discussed in previous examples that, unlike many other *E. coli* strains, *E. coli* strain DH5 does not produce an AI-2 signal compound that can be detected by *V. harveyi*. We reasoned therefore, that we could use *E. coli* DH5 as a mutant to clone the *V. harveyi* AI-2 production gene. A library of wild type *V. harveyi* BB120 genomic DNA was transformed into *E. coli* strain DH5, and the transformants were screened for AI-2 production in the *V. harveyi* BB170 AI-2 detection bioassay. The library consisted of 2,500 clones each containing roughly 25 kb of *V. harveyi* genomic DNA. Five DH5 clones were identified that resulted in upwards of 300-fold stimulation of the reporter strain in the bioassay.

[0235] The recombinant cosmid DNA from the five AI-2 producing *E. coli* DH5 clones was analyzed by restriction analysis and Southern blotting. All five of the cosmids contained an overlapping subset of identical *V. harveyi* genomic restriction fragments, indicating that we had cloned the same locus several times. One cosmid, called pBB2929 was selected for further analysis. Random mutagenesis using transposon Tn5 was carried out on cosmid pBB2929, and pools of cosmids harboring Tn5 insertions were subsequently transformed into *E. coli* DH5. We tested 962 individual *E. coli* DH5/pBB2929::Tn5 strains for the loss of the ability to produce AI-2. Four *E. coli* DH5 strains harboring Tn5 insertions in pBB2929 were identified that failed to produce AI-2. We mapped the locations of these Tn5 insertions in pBB2929 and found that all four transposon insertions resided in the same 2.6 kb *Hind*III *V. harveyi* genomic DNA fragment (Fig. 9A).

[0236] Cosmid pBB2929 was digested with *Hind*III and the 8 resulting fragments were subcloned in both orientations into pALTER (Promega). The pALTER subclones were transformed into *E. coli* DH5, and subsequently tested for AI-2 production. The only strains capable of producing AI-2 contained the 2.6 kb *Hind*III fragment identified in the Tn5 mutagenesis. This fragment was sequenced, and only one open reading frame (ORF) could be identified, and its location corresponded to the map positions of the four Tn5 insertions that eliminated AI-2 production. We named the ORF *luxS_{V,h}*. (Fig. 9A).

[0237] Mutagenesis of *luxS_{V,h}* in *V. harveyi*. We analyzed the effects of *luxS_{V,h}* null mutations on AI-2 production in *V. harveyi*. The four Tn5 insertions that mapped to the *luxS_{V,h}* gene and the control Tn5 insertion adjacent to the *luxS_{V,h}* locus were transferred to the corresponding locations in the

V. harveyi BB120 chromosome to make strains MM37, MM30, MM36, MM38 and MM28 respectively (Fig. 9A). Southern blotting was used to confirm the correct placement of all five Tn5 insertions in the *V. harveyi* chromosome. The four *V. harveyi luxS_{V.h.}::Tn5* insertion strains were tested for the ability to produce AI-2, and all four strains gave identical results.

[0238] In Fig. 10A, we show the AI-2 production phenotypes of the wild type control Tn5 insertion strain MM28 and one representative *luxS_{V.h.}::Tn5* insertion strain, MM30. *V. harveyi* MM28 and MM30 were grown to high cell density, after which cell-free culture fluids were prepared. The culture fluids were assayed for AI-2 activity by the ability to induce luminescence in the AI-2 detector strain BB170. Fig. 10A shows that addition of culture fluids from the control Tn5 insertion strain MM28 induced luminescence in the reporter 780-fold, while culture fluid from the *luxS_{V.h.}::Tn5* insertion strain MM30 did not induce the expression of luminescence in the reporter. Therefore, a null mutation in *luxS_{V.h.}* in *V. harveyi* eliminates AI-2 production.

[0239] Identification and analysis of *S. typhimurium* autoinducer production mutants. In order to identify the gene responsible for AI-2 production in *S. typhimurium*, we randomly mutagenized *S. typhimurium* LT2 using the MudJ transposon (Maloy *et al.*, 1996, *supra*). Ten-thousand *S. typhimurium* LT2 insertion mutants were assayed for AI-2 production in the *V. harveyi* BB170 bioassay. One *S. typhimurium* MudJ insertion mutant (strain CS132) was identified that lacked detectable AI-2 in culture fluids at mid-exponential phase.

[0240] Fig. 10B shows the AI-2 production phenotypes of *S. typhimurium* strain LT2 and the corresponding MudJ insertion strain CS132. The strains were grown to mid-exponential phase in LB containing glucose, and cell-free culture fluids were prepared and assayed for AI-2. *S. typhimurium* LT2 culture fluids induced the reporter strain 500-fold, while culture fluids from strain CS132 contained no AI-2 activity. Furthermore, strain CS132 did not produce AI-2 under any of the growth conditions that we have previously reported induce AI-2 production in *S. typhimurium* (not shown).

[0241] The site of the MudJ insertion in *S. typhimurium* CS132 was determined by PCR amplification followed by sequencing of the 110 bp of chromosomal DNA adjacent to the transposon. This sequence was used to search the database for DNA homologies. The sequence matched a site (89/105 bp identity) in the *E. coli* MG1655 genome that corresponded to an ORF of unknown function denoted *ygaG* (Blattner *et al.*, 1997, *supra*). In the chromosome, the *E. coli ygaG* gene is flanked by the *gshA* and *emrB* genes (Fig. 9B). The *ygaG* gene is transcribed from its own promoter which is located immediately upstream of the gene, indicating that it is not in an operon with *gshA*. The *emrB* gene is transcribed in the opposite direction. We PCR amplified the *ygaG* region from the chromosomes of *E. coli* O157:H7 and *E. coli* MG1655, and the two *E. coli ygaG* genes were cloned into pUC19.

[0242] Complementation of *S. typhimurium* and *E. coli* AI-2⁻ mutants. We tested whether the *E. coli* O157:H7 *ygaG* gene and the *V. harveyi luxS_{V.h.}* gene could restore AI-2 production in the AI-2⁻ strains *S. typhimurium* CS132 and *E. coli* DH5. In Fig. 11A, we show the AI-2 activity produced by wild

type *V. harveyi* BB120, *E. coli* O157:H7 and *S. typhimurium* LT2. In this figure, the level of AI-2 activity present in *V. harveyi* BB120 cell-free culture fluids was normalized to 100%, and the activities in cell-free culture fluids from *E. coli* and *S. typhimurium* compared to that. In this experiment, *E. coli* O157:H7 produced 1.5 times and *S. typhimurium* LT2 produced 1.4 times more AI-2 activity than *V. harveyi* BB120 (i.e., 150% and 141% respectively).

[0243] Fig. 11B and 11C show the AI-2 complementation results for *S. typhimurium* CS132 and *E. coli* DH5. Fig. 11B demonstrates that introduction of the *E. coli* O157:H7 *ygaG* gene into *S. typhimurium* CS132 restored AI-2 production beyond the level of production of wild type *S. typhimurium* (i.e., 209% activity). Comparison of the data in Fig. 11A and 11B shows that the *E. coli* *ygaG* gene in *S. typhimurium* resulted in AI-2 production exceeding that produced *in vivo* by *E. coli* O157:H7. Introduction of the *V. harveyi* *luxS_{V.h.}* gene into *S. typhimurium* resulted in AI-2 production at slightly less than the level produced by wild type *V. harveyi* BB120 (i.e., 73% of the level of *V. harveyi* BB120). Fig. 11C shows that *E. coli* DH5 was also complemented to AI-2 production by both the cloned *E. coli* O157:H7 and the *V. harveyi* BB120 AI-2 production genes. However, introduction of *E. coli* O157:H7 *ygaG* and *V. harveyi* BB120 *luxS_{V.h.}* into *E. coli* DH5 resulted in only 31% and 43% of the *V. harveyi* BB120 AI-2 activity respectively. Fig. 11B and 11C show that the control vectors produced no activity in the complementation experiments.

[0244] Analysis of the AI-2 production genes from *V. harveyi*, *E. coli* and *S. typhimurium*. We sequenced the AI-2 production gene *luxS_{V.h.}* from *V. harveyi* BB120 and the *ygaG* loci from *E. coli* O157:H7, *E. coli* MG1655 and *E. coli* DH5. The translated protein sequences encoded by the *ygaG* ORF's are shown in Figure 12, and they are aligned with the translated LuxS protein sequence from *V. harveyi*. The non-bold, underlined amino acids indicate the residues in the *E. coli* proteins that differ from the *V. harveyi* LuxS protein. The *ygaG* loci from *E. coli* encode proteins that are highly homologous to one another and also to LuxS from *V. harveyi*. The *E. coli* MG1655 and the *E. coli* O157:H7 YgaG proteins are 77% and 76% identical to LuxS from *V. harveyi* BB120. The DNA sequence we determined for *ygaG* from *E. coli* O157:H7 differs at five sites from the reported (and our) sequence for the *E. coli* MG1655 *ygaG* gene. Four of the changes are silent, the fifth results in a conservative Ala to Val alteration at amino acid residue 103 in the *E. coli* O157:H7 protein.

[0245] Identification of the *ygaG* locus in *E. coli* MG1655 and *E. coli* O157:H7 allowed us to investigate the AI-2 production defect in *E. coli* DH5. *E. coli* DH5 possesses the *ygaG* gene because we could PCR amplify this region from the chromosome using the same primers we employed to amplify it from *E. coli* MG1655 and *E. coli* O157:H7. Examination of the *E. coli* DH5 *ygaG* promoter showed that it is identical to that of *E. coli* MG1655, indicating that the AI-2 defect in *E. coli* DH5 is not simply due to decreased transcription of *ygaG*. However, sequence analysis of the *E. coli* DH5 *ygaG* coding region showed that a one G-C base pair deletion and a T to A transversion exist at bp 222 and 224 respectively. The frameshift mutation resulting from the G/C deletion causes premature truncation of

the *E. coli* DH5 protein. Figure 12 shows that the truncated *E. coli* DH5 protein is 111 amino acids, while the *E. coli* MG1655 and *E. coli* O157:H7 proteins are 171 residues. Twenty altered amino acids are translated after the frame shift and prior to termination of the protein. Our complementation results (Figure 11) demonstrate that the AI-2 production defect in *E. coli* DH5 is recessive to *in trans* expression of *ygaG*, which is consistent with the defect being due to a null mutation caused by the frame shift in the *E. coli* DH5 *ygaG* gene.

[0246] We searched the *S. typhimurium* database using the sequence we obtained adjacent to the MudJ that inactivated the AI-2 production function in *S. typhimurium* CS132. A perfect match (110/110 bp) was identified to fragment B_TR7095.85-T7 in the *S. typhimurium* LT2 genome sequencing database (Genome Sequencing Center, Washington University, St. Louis). However, the *S. typhimurium* LT2 database *ygaG* sequence is incomplete (Figure 12). The translated sequence matches the *E. coli* and *V. harveyi* sequences beginning at amino acid residue 8. The translated sequence shows that the *S. typhimurium* protein is 75% identical to LuxS of *V. harveyi*. In order to align the *S. typhimurium* sequence with the *V. harveyi* LuxS protein, we corrected three apparent frame shift errors in the database sequence. Considering that only crude, unannotated sequence data is currently available for *S. typhimurium*, we predict that the *S. typhimurium* protein contains 7 more amino acids, and that the frame shift mutations are sequencing errors. We were unsuccessful at PCR amplifying either the *S. typhimurium* 14028 or the *S. typhimurium* LT2 *ygaG* gene using the primers designed for *E. coli*, so we do not yet have the complete sequence of the *S. typhimurium* gene.

[0247] The results set forth above indicate that the genes we have identified and analyzed encode a novel family of proteins responsible for autoinducer production. Members of this new family of genes, referred to herein as *LuxS*, are highly homologous to one another but not to any other identified genes. The encoded product of the *LuxS* genes catalyze an essential step in the synthesis of the signaling compounds of the present invention.

EXAMPLE 4

Construction of a Sensor 1⁻, AI2⁻ *V. harveyi* Reporter Strain

[0248] *V. harveyi* null mutants in each of the *lux* genes *luxL*, *luxM*, *luxN*, *luxS* and *luxQ* have been constructed. These mutants fail to either make or respond to one specific autoinducer, but they still produce light because, in each case, one quorum sensing system remains operational. A double *luxN*, *luxS* *V. harveyi* mutant will not emit light without the addition of exogenous AI-2 because this mutant will not respond to AI-1 and it will not produce AI-2.

[0249] The *V. harveyi* *luxS* gene has been cloned into *E. coli* DH5 α on a broad host range mobilizable cosmid called pLAFR2. This construction restores AI-2 production to *E. coli* DH5 α . A marked null mutation was engineered into the *luxS* gene by introducing a chloramphenicol resistance (Cm^r) cassette into an internal restriction site. Placement of the Cm^r cassette at this site in *luxS* subsequently eliminated AI-2 production in *E. coli* DH5 α .

[0250] The *luxS*::Cm^r null allele was transferred onto the chromosome of *V. harveyi* strain BB170. Strain BB170 contains a Tn5Kan^r in *luxN* and does not respond to AI-1. To construct the double mutant, triparental conjugations were carried out by mixing stationary phase cultures of *E. coli* DH5 α carrying the *V. harveyi luxS*::Cm^r construction in pLAFR2 (pLAFR2 carries tetracycline resistance), *E. coli* DH5_ carrying the *tra* donor plasmid pRK2013 and the *V. harveyi* recipient strain BB170. Exchange of the *luxS*::Cm^r mutant allele for the wild type *luxS* allele on the chromosome occurs by homologous recombination. The exogenote cosmid in *V. harveyi* was eliminated by the introduction of a second incompatible plasmid pPH1JI. This was accomplished by mating *E. coli* DH5 α containing pPH1JI with the *V. harveyi* BB170 recipient containing the *luxS*::Cm^r cosmid, and selecting for exconjugants on plates containing ampicillin (for counter selection of the *E. coli* donor) chloramphenicol (for inheritance of the mutant *luxS*::Cm^r allele) and gentamicin (for maintenance of the plasmid pPH1JI). Southern blot analysis was used to verify that the exogenote pLAFR2 cosmid has been eliminated and that the *luxS*::Cm^r construction had been transferred to the corresponding position in the genome of *V. harveyi*. The pPH1JI cosmid was subsequently eliminated by growth in the absence of gentamicin selection.

[0251] Verification that the *luxN*, *luxS* Double Mutant Responds to AI-2. The *V. harveyi* strain that is mutant in *luxN* and *luxS* was stimulated to produce light in response to the exogenous addition of AI-2 but not AI-1. This was verified in a luminescence assay for response to *V. harveyi* AI-1 and AI-2. *V. harveyi* strain MM30 (*luxS*::Tn5) which is phenotypically AI-1⁺, AI-2⁻, and *V. harveyi* strain BB152 (*luxM*::Tn5) which is phenotypically AI-1⁻, AI-2⁺ were used as the sources of AI-1 and AI-2 respectively. The AI-1 and AI-2 present in culture fluids of these strains was tested for stimulation of light production of the *V. harveyi luxN*, *luxS* double mutant reporter strain. In this assay, autoinducer preparations from MM30, BB152 or sterile medium controls were added to the wells of microtiter plates, followed by the addition of the *V. harveyi* reporter strain. The resulting light production was monitored using a liquid scintillation counter in the chemiluminescence mode. Maximal stimulation of light production in the *V. harveyi luxN*, *luxS* reporter strain was compared to that produced by the Sensor 1⁺, Sensor 2⁻ *V. harveyi* strain BB886 and the Sensor 1⁻, Sensor 2⁺ *V. harveyi* strain BB170. These two *V. harveyi* strains are routinely used in this assay as reporters of AI-1 and AI-2 activity respectively.

[0252] Determine optimum concentrations of AI-2 in microtiter assays. The aforementioned screen will be optimized for use in 96-well microtiter assays. The screen will be used in inhibitor assays for identifying inhibitors of AI-2. Purified or synthetic AI-2 will be added to the microtiter wells containing the newly constructed reporter strain and inhibition will be measured by a decrease in light emission from the wells containing an inhibitor. The assay will be optimized by determining the concentration of cells and AI-2 in the microtiter wells that will allow for maximal sensitivity. The optimal AI-2 concentration will be that which stimulates half-maximal light output for a given concentration of cells per unit time. Initial experiments will be conducted in this concentration range to

determine the range of AI-2 concentration that produces the greatest change in light output. Similar experiments using AI-1 and a non self-stimulating sensor-1⁺, sensor-2⁻ mutant (BB886) showed that the assay was sensitive to concentrations as low as 100nM AI-1 and that light emission was linear over 6 orders of magnitude (light emission from a self-stimulating strain was linear over 3 orders). Similar results for AI-2 using the new reporter strain which will not self-stimulate and therefore have zero background light emission are predicted. Light emission from the microtiter wells will be measured with a Wallac TriLux liquid scintillation counter model 1450-021 in the chemiluminescence mode. This machine will accommodate 16 plates and will therefore allow for 1536 separate concentration experiments per run.

EXAMPLE 5

In-Vitro Method for Synthesizing AI-2

[0253] Purification and Identification of AI-2. The AI-2 class of compound is refractory to purification by conventional techniques used for the isolation of acyl-homoserine lactone (HSL) autoinducers such as AI-1 from *V. harveyi*. Unlike other HSL autoinducers, under the conditions tested, the AI-2 activity does not extract quantitatively into organic solvents. Furthermore, it fails to bind to either a cation or anion exchange column. The present characterization of AI-2 indicates that it has a molecular weight of less than 1000 kDa, and is a polar but apparently uncharged organic compound. The AI-2 activity is acid stable and base labile and heat resistant to about 80 but not 100°C. These results indicate that the AI-2's are not acyl-homoserine lactones. The *luxS* genes identified in the present study bear no homology to other genes known to be involved in production of HSL autoinducers further indicating that the present AI-2 class of autoinducers is novel.

[0254] Thus, in addition to providing a cloned, overexpressed and purified *S. typhimurium* LuxS protein, the present invention also provides a method for producing AI-2 *in vitro*. The present invention provides a mechanism for generating large quantities of pure AI-2 useful for mass spectral and NMR analysis, and for screening compounds which modulate the activity of AI-2. Moreover, the present invention provides a method for determining the *in vivo* biosynthetic pathway for AI-2 synthesis.

[0255] The analysis of the genomic locations of the various *luxS* genes identified in the present invention indicates that the *luxS* genes do not consistently reside in any one location in the chromosome, nor are they typically found in close proximity to any specific gene(s). However, in one case, the *luxS* gene is the third gene in a three-gene operon with two genes (*metK* and *pfs*). In *E. coli*, *Salmonella* and many other bacteria, MetK and Pfs are involved in the conversion of S-adenosyl methionine (SAM) to homocysteine and 4,5-dihydroxy-2,3 pentanedione (Figure 15). The function of MetK is to convert methionine to SAM which is an important cofactor in one-carbon metabolism. SAM is used to methylate DNA, RNA and a variety of cell proteins, and several SAM dependent methyl transferases act at this step. S-adenosyl homocysteine (SAH) is produced when the methyl group is transferred from SAM to its substrates. SAH functions as a potent inhibitor of SAM dependent methyltransferases. Therefore,

bacteria rapidly degrade SAH via the enzyme Pfs. The designation "pfs" refers to an open reading frame in the *E. coli* genome that has recently been determined to encode the enzyme 5'-methylthioadenosine/S-adenosylhomocysteine nucleosidase, also known as MTA/SAH nucleosidase. In the present system, the enzyme cleaves the glycosidic bond in S-adenosylhomocysteine (SAH). Thus, the function of Pfs is to convert SAH to adenine and S-ribosyl homocysteine. In a final step, S-ribosyl homocysteine is converted to homocysteine and 4,5-dihydroxy-2,3-pentanedione. Homocysteine can re-enter this pathway; it is methylated to generate methionine which can be converted to SAM by MetK.

[0256] The catabolism of SAH is considered a salvage pathway for recycling metabolic intermediates (adenine and homocysteine). However, some species of bacteria eliminate SAH by a different pathway. In this alternative pathway, adenosine is directly removed from SAH which generates homocysteine. Therefore, cells that use this second mechanism do not produce 4,5-dihydroxy-2,3-pentanedione. In the pathway shown in Figure 15, the enzyme responsible for conversion of S-ribosyl homocysteine to 4,5-dihydroxy-2,3-pentanedione has never been identified, cloned or purified. Furthermore, no role for 4,5-dihydroxy-2,3-pentanedione is known.

[0257] LuxS is involved in the pathway shown in Figure 15, and SAM and SAH are involved in AI-2 production. The structure of AI-2 could be 4,5-dihydroxy-2,3-pentanedione, in which case LuxS is the uncharacterized enzyme that acts on S-ribosyl homocysteine. Second, LuxS could act on one of the intermediates to make AI-2. LuxS would represent a branch point off the known pathway.

[0258] To confirm that LuxS is involved in the conversion of SAM to AI-2, the gene encoding the *S. typhimurium* LuxS protein was cloned, overexpressed and the *S. typhimurium* LuxS protein was purified. This protein was used in combination with dialyzed cell-free extracts prepared from a *S. typhimurium luxS* null mutant to show that addition of SAM and LuxS protein could restore AI-2 production to dialyzed LuxS- cell extracts. Reaction mixtures were prepared containing 10 mM Sodium Phosphate buffer pH 7.0, dialyzed *S. typhimurium* LuxS- cell extract and SAM. Purified LuxS protein was added to some of these mixtures. The reactions were incubated at room temperature for 60 min, followed by centrifugation in a 5000 MWCO centricon. The material with MW < 5000 was added to the standard *V. harveyi* bioassay as previously described. Dialyzed LuxS- cell extracts to which SAM was added or extracts containing LuxS protein without the addition of SAM produced no AI-2 activity. However, identical extracts to which LuxS protein and SAM had been added produced AI-2 that resulted in over 500-fold stimulation in light production in the bioassay.

[0259] Further investigation showed that SAM is not the direct substrate for LuxS, and that LuxS must act at a step subsequent to the conversion of SAM to SAH (Figure 15). It was determined that AI-2 was not produced if SAM was added directly to LuxS protein, however activity was produced by pre-incubation of SAM with the LuxS- extracts, filtration, and subsequent addition of LuxS protein to the filtrate. Importantly, these studies indicate that SAM can react with an element in the cell extract before it can be used by LuxS to make AI-2. Presumably, the SAM dependent methyl transferases

present in the cell extract use SAM as a methyl donor and convert it to SAH in the process. To verify this, SAH was substituted for SAM in an *in vitro* assay. Addition of SAH to the *in vitro* assay resulted in much greater AI-2 production than when SAM was added. This result indicates that LuxS functions in the pathway subsequent to the conversion of SAM to SAH. Again, addition of SAH directly to LuxS protein is not sufficient for production of AI-2 activity, while pre-incubation of SAH with dialyzed LuxS- extracts followed by filtration and subsequent addition of LuxS protein to the filtrates does result in AI-2 production. Presumably SAH is converted to S-ribosyl homocysteine and then LuxS acts to produce AI-2.

[0260] The proposed pathway shown in Figure 15 is not a salvage pathway for recycling secondary metabolites, but rather is the pathway for production of AI-2. The present invention has narrowed the possibilities for point of LuxS activity in the biosynthesis of AI-2. The remaining possibilities are shown in Figure 15 (designated LuxS?).

[0261] According to the invention, AI-2 is a derivative of ribose. It is noteworthy that, in *V. harveyi*, LuxP, the primary sensor for AI-2, is a homologue of the *E. coli* and *S. typhimurium* ribose binding protein.

[0262] Characterization and Biosynthesis of AI-2. The invention further provides a method for an *in vitro* procedure for large scale production of pure AI-2. As indicated in Figure 15, SAH is a precursor in the LuxS dependent biosynthesis of AI-2. Furthermore, LuxS does not act directly on SAH. Prior to the action of LuxS, SAH must first be acted on by some enzyme in dialyzed cell extracts. Presumably this step is the conversion of SAH to S-ribosyl homocysteine by Pfs. Therefore the substrate for LuxS is S-ribosyl homocysteine.

[0263] To confirm that LuxS acts on S-ribosyl homocysteine, the Pfs enzyme can be purified and used to convert SAH to S-ribosyl homocysteine. Toward this end, the *pfs* gene has been cloned from *S. typhimurium* 14028 placed into the overexpression vector pLM-1. The Pfs enzyme will be overexpressed and SAH will be added to purified Pfs to produce S-ribosyl homocysteine. The conversion of SAH to S-ribosyl homocysteine will be confirmed by reverse phase HPLC analysis (SAH is UV active while S-ribosyl homocysteine is not). Subsequently, the S-ribosyl homocysteine produced by Pfs will be added to purified LuxS. Following incubation, the mixture will be filtered over a 5000 MWCO centricon. The filtrate will be tested for AI-2 activity in the previously described *V. harveyi* bioassay. The identification of activity will confirm that 4,5-dihydroxy-2,3-pentanedione is AI-2.

[0264] In addition, AI-2 structure obtained from *E. coli* and *V. harveyi* AI-2 will be determined. The *E. coli* and *V. harveyi luxS* genes have been cloned in to overexpression vectors. The identity/biosynthesis of the *S. typhimurium* AI-2 provided by the present invention should greatly facilitate these analyses. In the event that the *S. typhimurium*, *E. coli* and *V. harveyi* AI-2's are identical these data will indicate that AI-2's are the same.

EXAMPLE 6

Identification of Compounds that Modulate the Response to AI-2

[0265] A library of chemical compounds generated by combinatorial chemistry techniques is obtained. A plurality of test mixtures is generated wherein each test mixture contains one or more of the compounds from the library and AI-2. Each of the test mixtures is placed in contact with a culture of *Vibrio harveyi* MM32 cells and bioluminescence is measured as described above. The amount of bioluminescence from each the cultures contacted with the test mixtures is compared to the amount of bioluminescence from a control culture of *Vibrio harveyi* MM32 cells that was contacted with AI-2 but not with a compound from the library.

[0266] A test mixture that resulted in a reduced level of bioluminescence relative to the control culture is identified. This test mixture contains a compound that decreases the response to AI-2. The compound is purified and its structure is determined. The compound may be directly useful as an antimicrobial compound to reduce the extent of an infection or, alternatively, the compound may be further optimized to produce a compound that may be used to to reduce the extent of an infection.

[0267] The present invention is not limited to the embodiments described and exemplified above, but is capable of variation and modification within the scope of the appended claims.

WHAT IS CLAIMED IS:

1. A method for identifying a compound that modulates the response to a first autoinducer that is not an acyl-homoserine lactone and which is able to interact with the *Vibrio harveyi* LuxQ protein thereby inducing expression of a *Vibrio harveyi* operon comprising the luxCDABE genes, comprising:

obtaining a cell that produces a detectable signal in response to the first autoinducer;
measuring the response of the cell to the first autoinducer in the presence and absence of a test compound; and

comparing the responses to determine whether the test compound modulates the response to the first autoinducer.

2. The method of Claim 1, wherein the cell has a first genetic alteration that inhibits production of the first autoinducer.

3. The method of Claim 2, wherein the first genetic alteration has been introduced in the cell by genetic engineering.

4. The method of Claim 2, wherein the first autoinducer is the autoinducer-2 produced by *Vibrio harveyi*.

5. The method of Claim 2, wherein the first genetic alteration inhibits production of a pentanedione.

6. The method of Claim 5, wherein the pentanedione is 4,5-dihydroxy-2,3-pentanedione.

7. The method of Claim 2, wherein the cell belongs to a species selected from the group consisting of *S. typhimurium* and *E. coli*.

8. The method of Claim 2, wherein the cell belongs to a species selected from the group consisting of *Haemophilus influenzae*, *Helicobacter pylori*, *Bacillus subtilis*, *Borrelia burgdorferi* and *Vibrio cholerae*.

9. The method of Claim 2, wherein the cell is a *Vibrio harveyi* cell.

10. The method of Claim 9, wherein the first genetic alteration is in the *luxS* gene.

11. The method of Claim 2, wherein the first genetic alteration is in a nucleotide sequence having at least 50% nucleotide sequence identity to the *luxS* gene of *V. harveyi*.

12. The method of Claim 11, wherein the first genetic alteration is in a nucleotide sequence having at least 60% nucleotide sequence identity to the *luxS* gene of *V. harveyi*.

13. The method of Claim 12, wherein the first genetic alteration is in a nucleotide sequence having at least 80% nucleotide sequence identity to the *luxS* gene of *V. harveyi*.

14. The method of Claim 2, wherein the first genetic alteration is in a gene encoding a protein having at least 57% sequence homology to the LuxS protein of *V. harveyi*.

15. The method of Claim 14, wherein the first genetic alteration is in a gene encoding a protein having at least 85% sequence homology to the LuxS protein of *V. harveyi*.

16. The method of Claim 15, wherein the first genetic alteration is in a gene encoding a protein having at least 32% sequence identity to the LuxS protein of *V. harveyi*.

17. The method of Claim 16, wherein the first genetic alteration is in a gene encoding a protein having at least 45% sequence identity to the LuxS protein of *V. harveyi*.

18. The method of Claim 17, wherein the first genetic alteration is in a gene encoding a protein having at least 74% sequence identity to the LuxS protein of *V. harveyi*.

19. The method of Claim 18, wherein the first genetic alteration is in a gene encoding a protein having at least 80% sequence identity to the LuxS protein of *V. harveyi*.

20. The method of Claim 2, wherein the cell has a second genetic alteration that inhibits detection of a second autoinducer.

21. The method of Claim 20, wherein the second autoinducer is an acyl-homoserine lactone.

22. The method of Claim 21, wherein the second autoinducer is N-(3-hydroxyacyl)-L-homoserine lactone and the acyl group comprises 4-12 carbon atoms.

23. The method of Claim 22, wherein the acyl group comprises four carbon atoms.

24. The method of Claim 2, wherein the response of the cell is bioluminescence.

25. A method for identifying a compound that modulates the response to a non-acyl-homoserine lactone autoinducer which is able to interact with the *Vibrio harveyi* LuxQ protein thereby inducing expression of a *Vibrio harveyi* operon comprising the luxCDABE genes, comprising:

obtaining an isolated and purified bacterial strain comprising a first genetic alteration that inhibits production of a first autoinducer that is not an acyl-homoserine lactone, and a second genetic alteration that inhibits detection of a second autoinducer that is an acyl-homoserine lactone;

measuring the response of the bacterial strain to the first autoinducer in the presence and absence of a test compound; and

comparing the responses to determine whether the compound modulates the response to the second autoinducer.

26. The method of Claim 25, wherein the bacterial strain is a strain of *Vibrio harveyi*.

27. The method of Claim 26, wherein the response is bioluminescence.

28. The method of Claim 26, wherein the first alteration is in the *luxS* gene.
29. The method of Claim 28, wherein the second alteration is in the *luxN* gene.
30. The method of Claim 25, wherein the first alteration inhibits production of the autoinducer-2 produced by *Vibrio harveyi*.
31. The method of Claim 25, wherein the bacterial strain belongs to a species other than *Vibrio harveyi*.
32. The method of Claim 31, wherein the bacterial strain belongs to a species selected from the group consisting of *S. typhimurium* and *E. coli*.
33. The method of Claim 31, wherein the bacterial strain belongs to a species selected from the group consisting of *Haemophilus influenzae*, *Helicobacter pylori*, *Bacillus subtilis*, *Borrelia burgdorferi* and *Vibrio cholerae*.
34. The method of Claim 25, wherein the second autoinducer is N-(3-hydroxyacyl)-L-homoserine lactone and the acyl group comprises 4-12 carbon atoms.
35. The method of Claim 26, wherein the first alteration inhibits production of the autoinducer-2 produced by *Vibrio harveyi*.
36. The method of Claim 25, wherein the first and second alterations have been introduced into the strain by genetic engineering.
37. The method of Claim 25, wherein the first alteration inhibits production of a pentanedione.
38. The method of Claim 25, wherein the pentanedione is 4,5-dihydroxy-2,3-pentanedione.
39. The method of Claim 25, wherein the second autoinducer is N-(3-hydroxybutanoyl)-L-homoserine lactone.
40. The method of Claim 25, wherein the first alteration is in a nucleotide sequence having at least 50% nucleotide sequence identity to the *luxS* gene of *V. harveyi*.
41. The method of Claim 40, wherein the first alteration is in a nucleotide sequence having at least 60% nucleotide sequence identity to the *luxS* gene of *V. harveyi*.
42. The method of Claim 41, wherein the first alteration is in a nucleotide sequence having at least 80% nucleotide sequence identity to the *luxS* gene of *V. harveyi*.
43. The method of Claim 42, wherein the first alteration is in a gene encoding a protein having at least 57% sequence homology to the LuxS protein of *V. harveyi*.
44. The method of Claim 43, wherein the first alteration is in a gene encoding a protein having at least 85% sequence homology to the LuxS protein of *V. harveyi*.

FIG. 1B

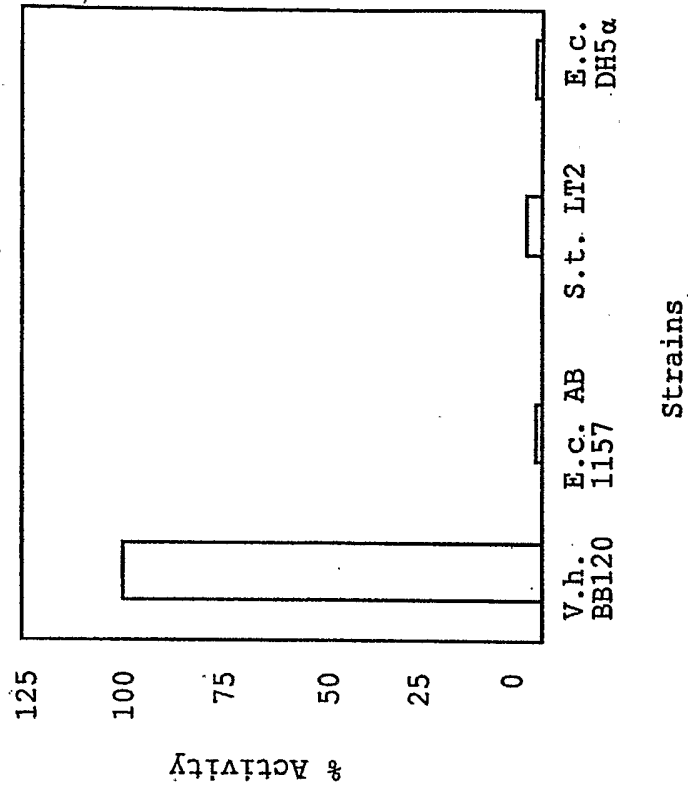

FIG. 1A

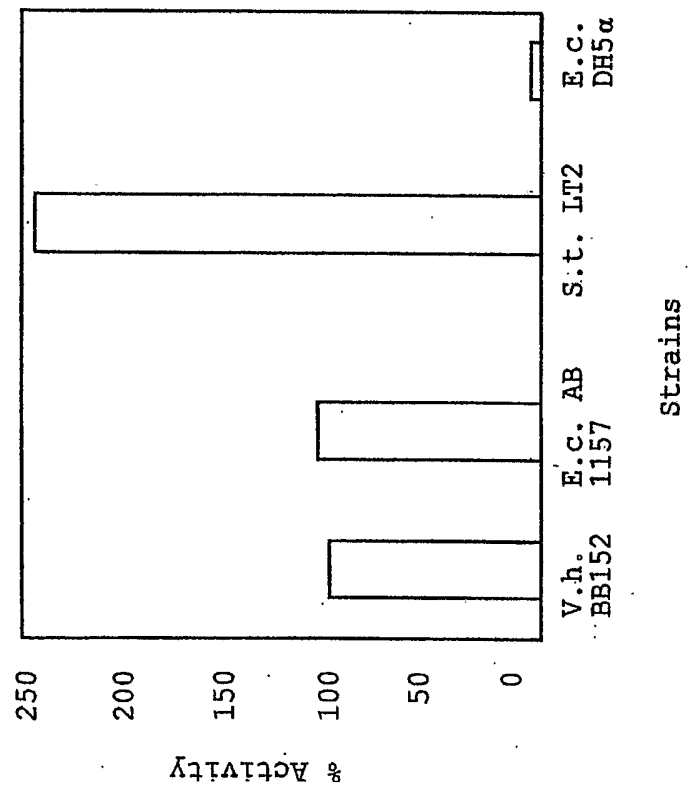
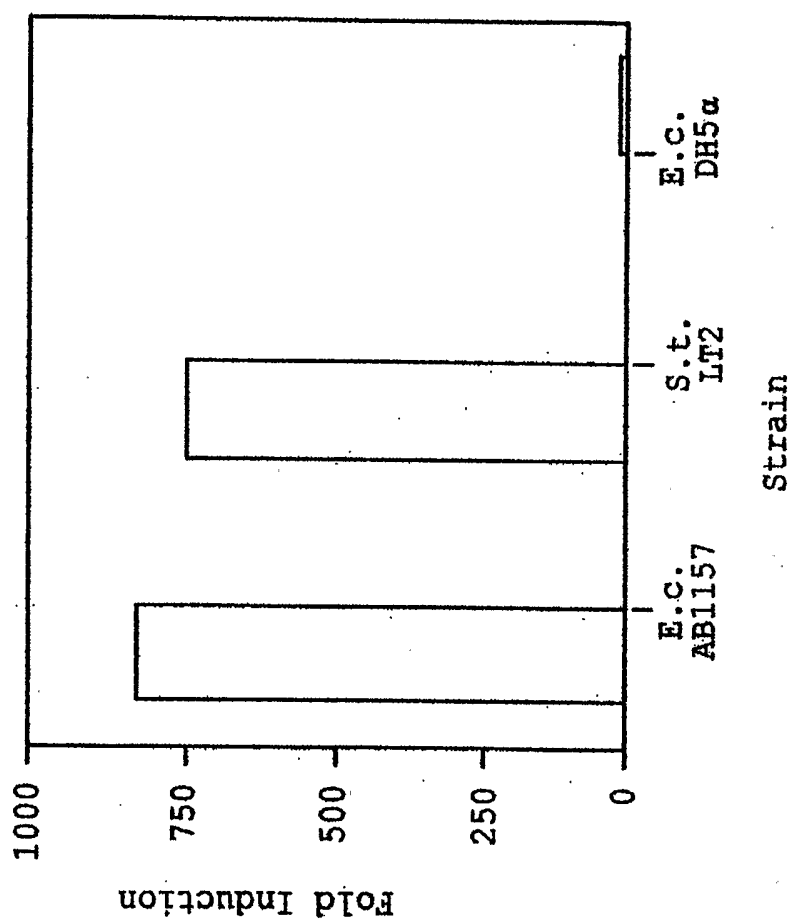
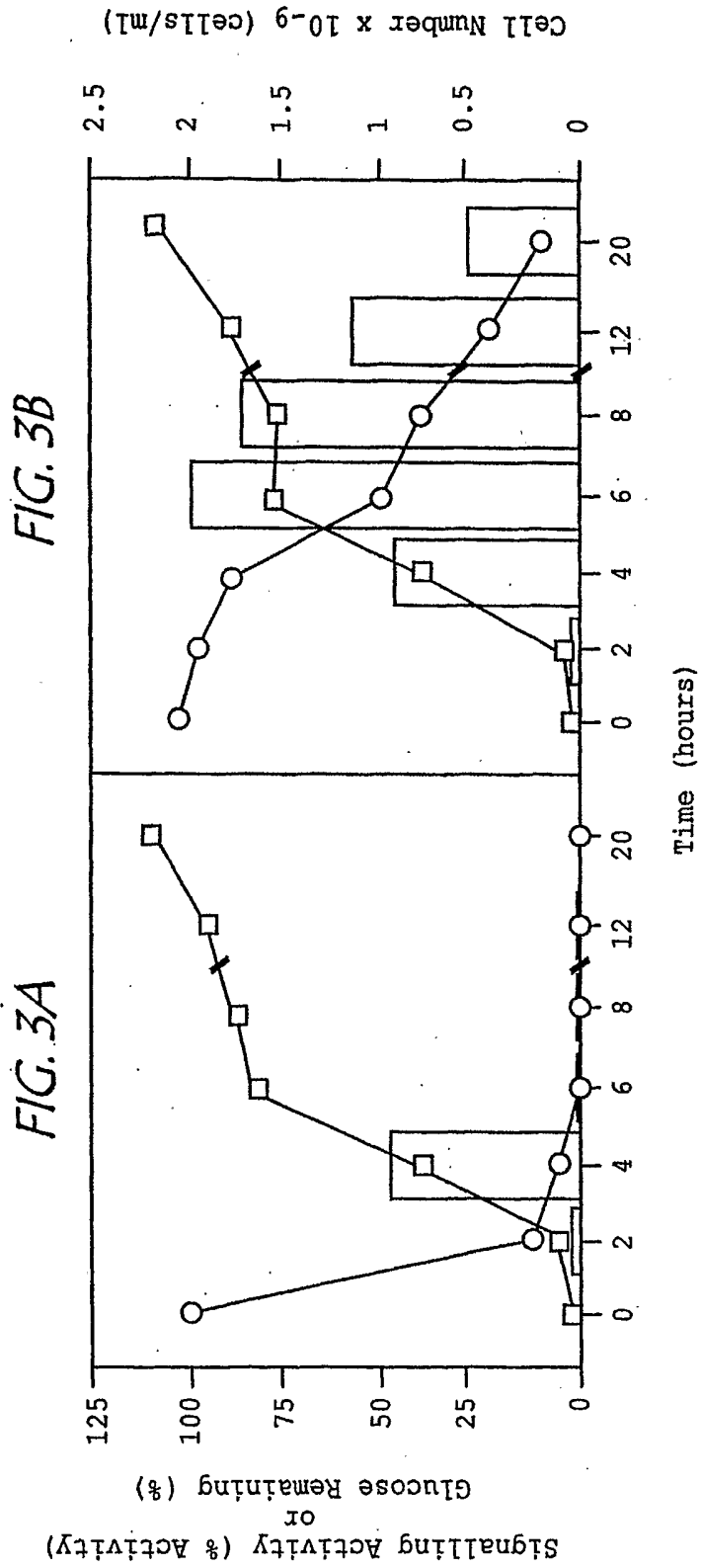
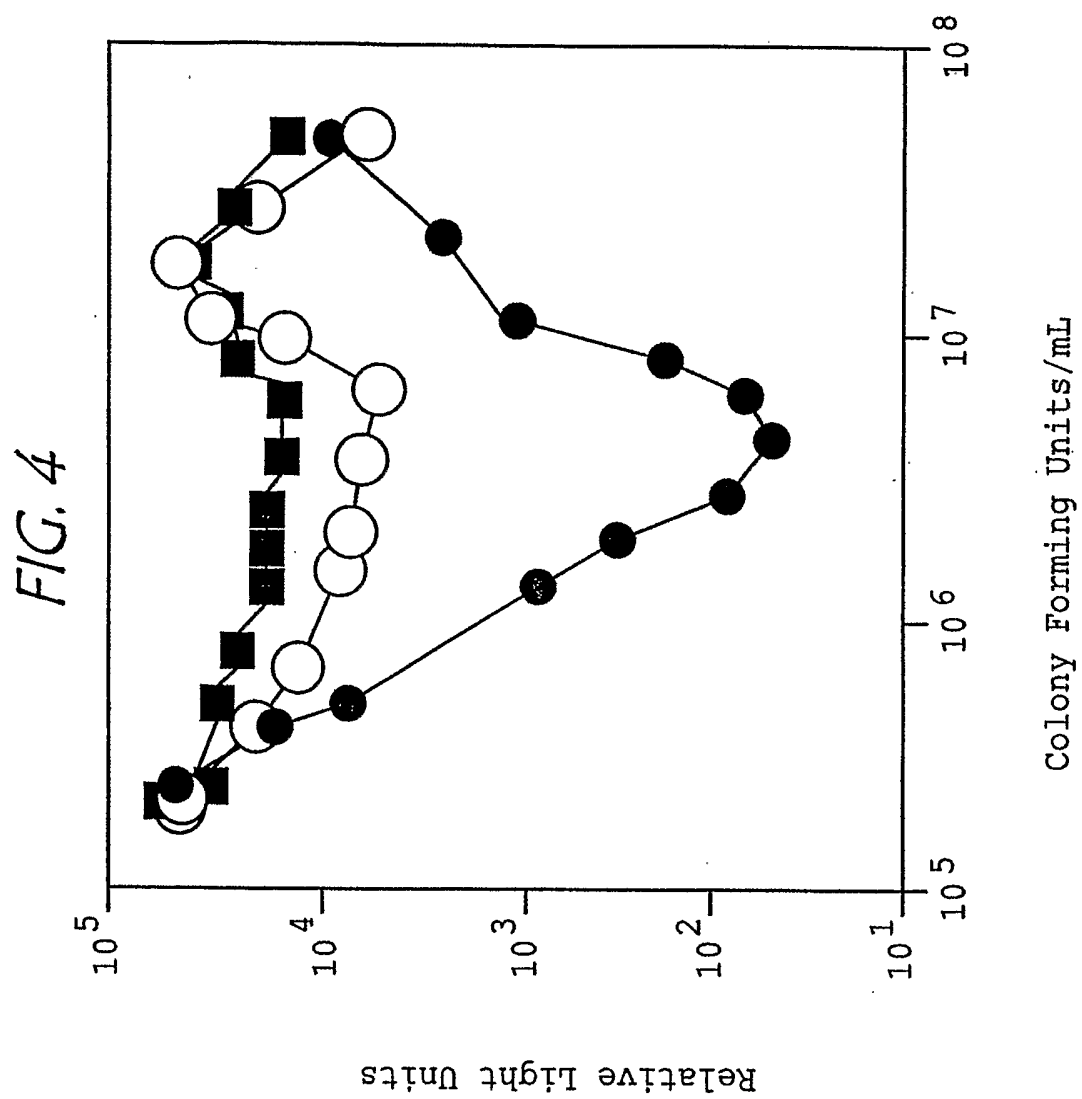

FIG. 2







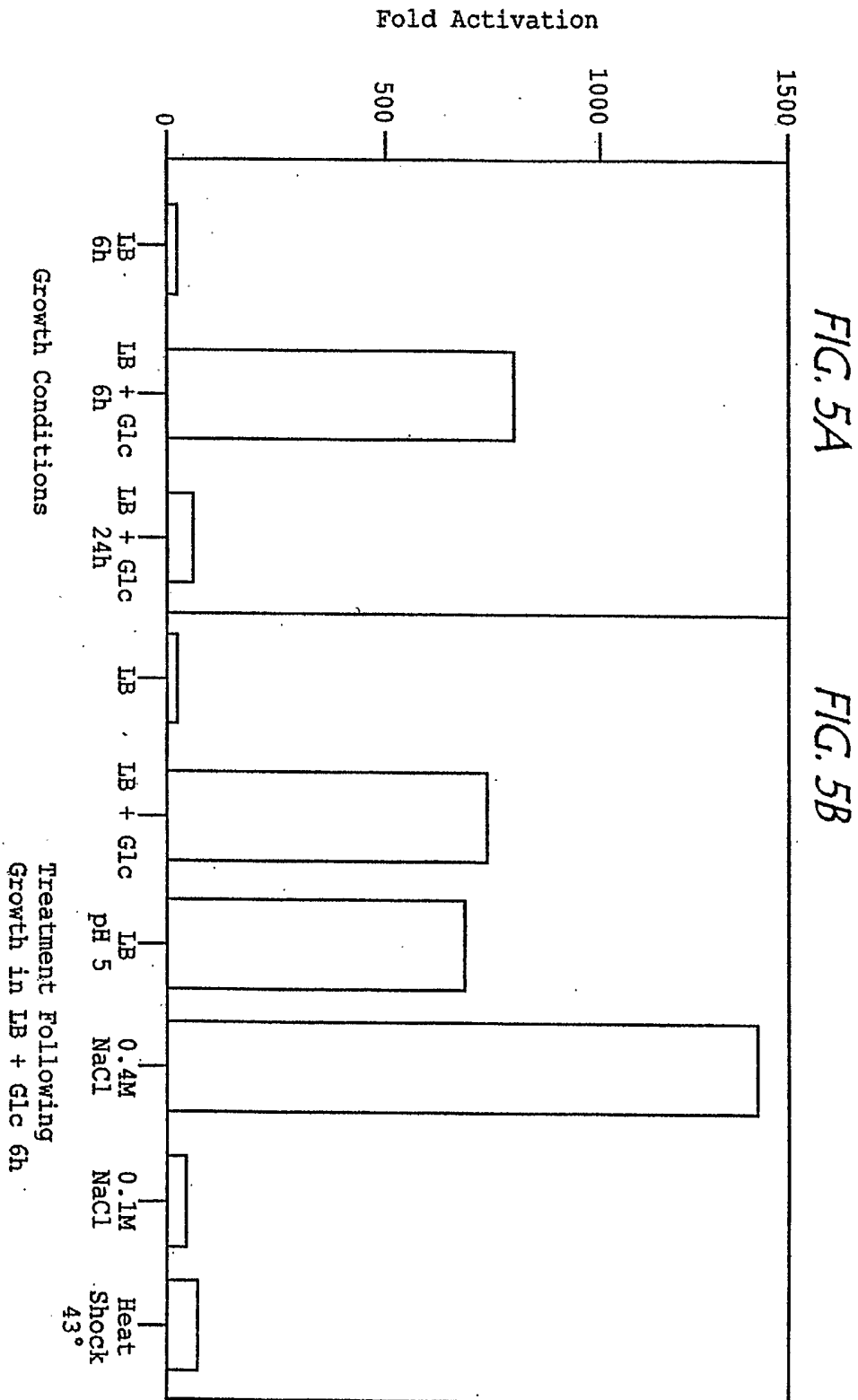

FIG. 5A

FIG. 5B

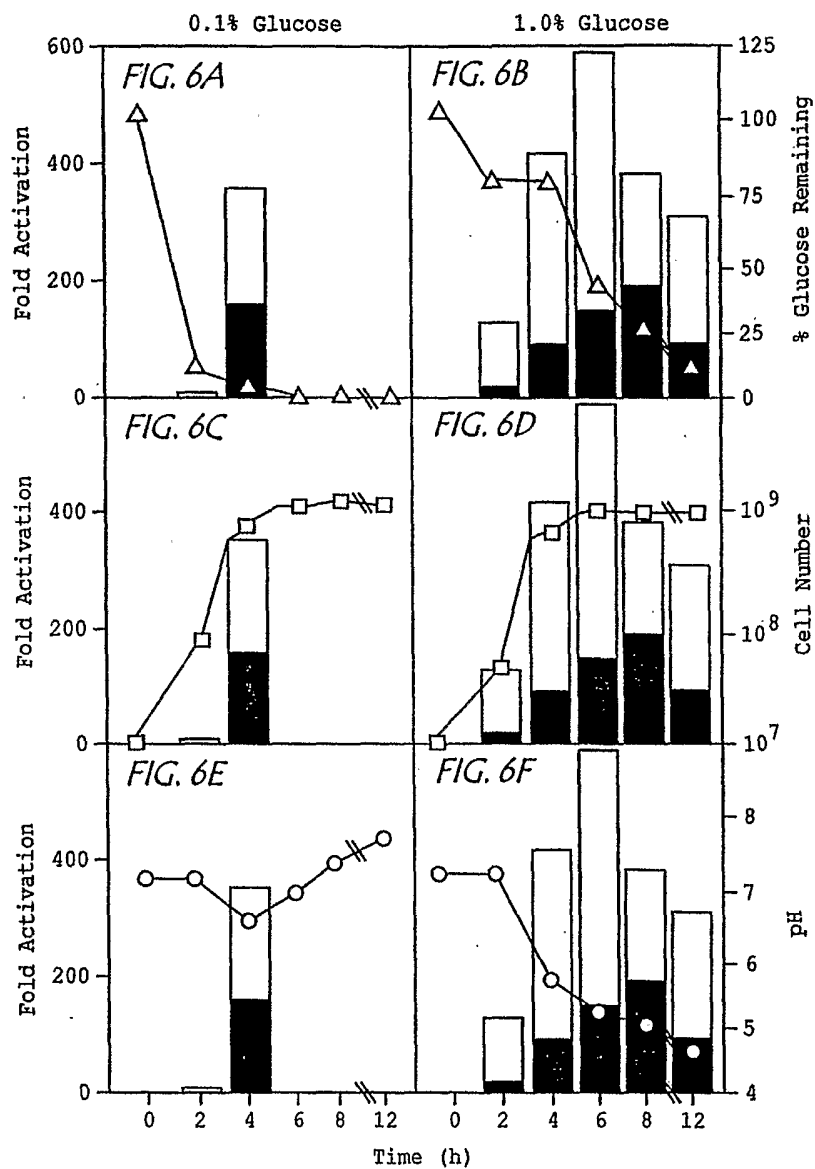

FIG. 7A

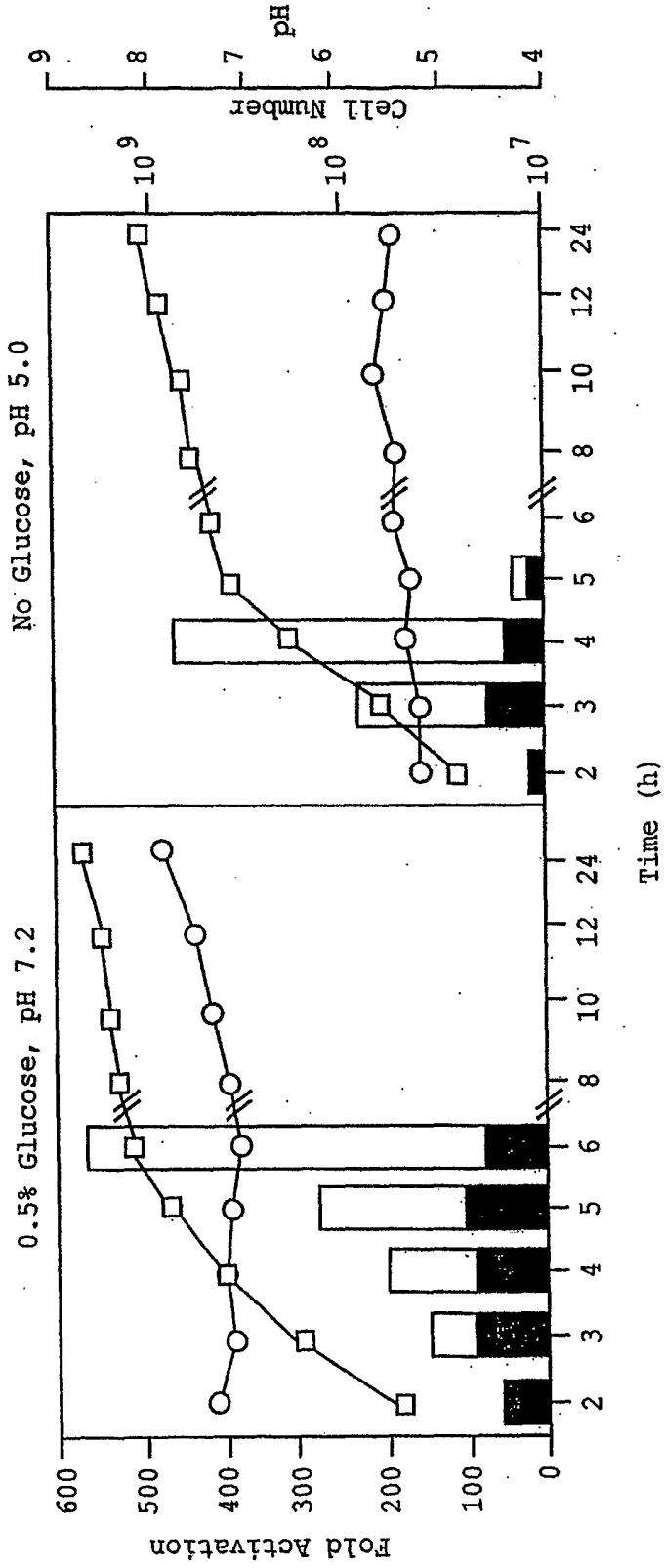

FIG. 7B

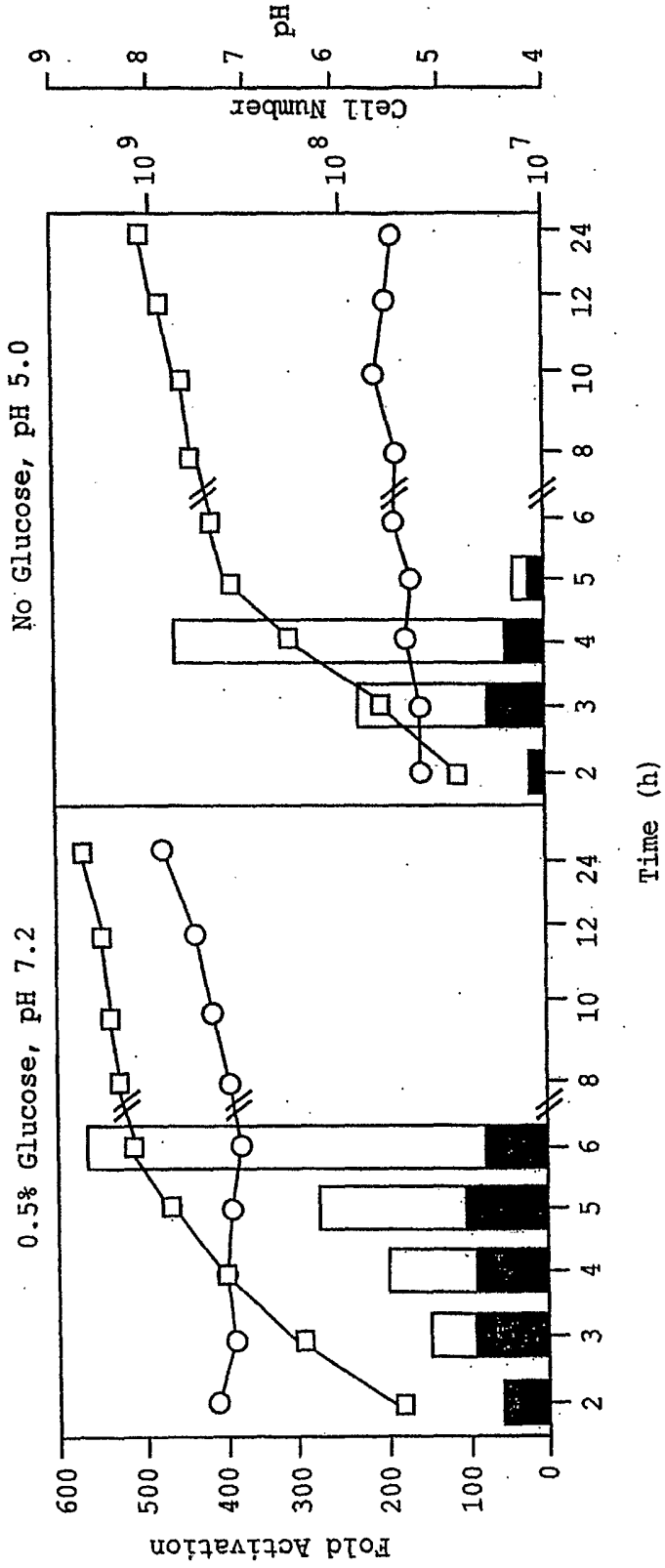

FIG. 8B

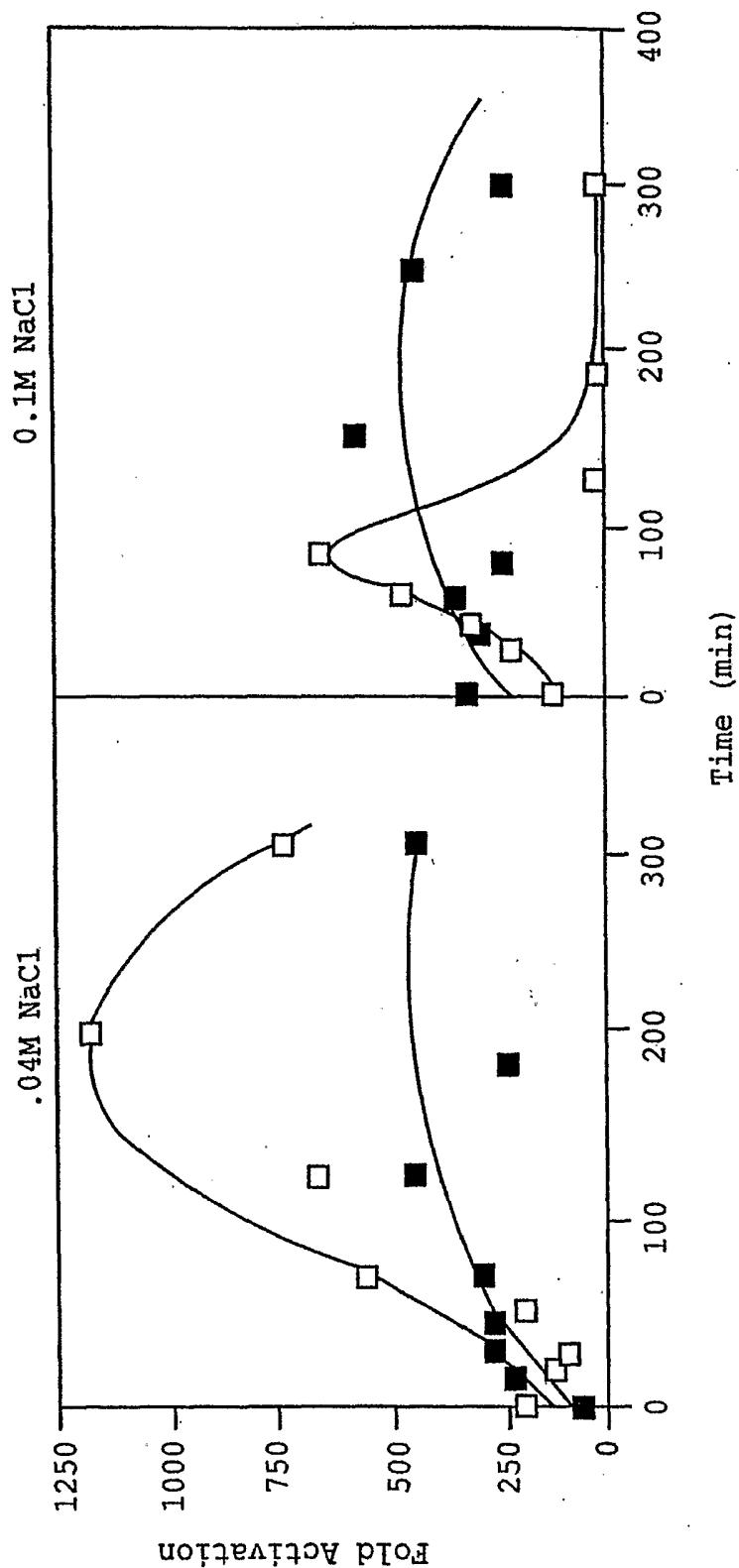

FIG. 8A

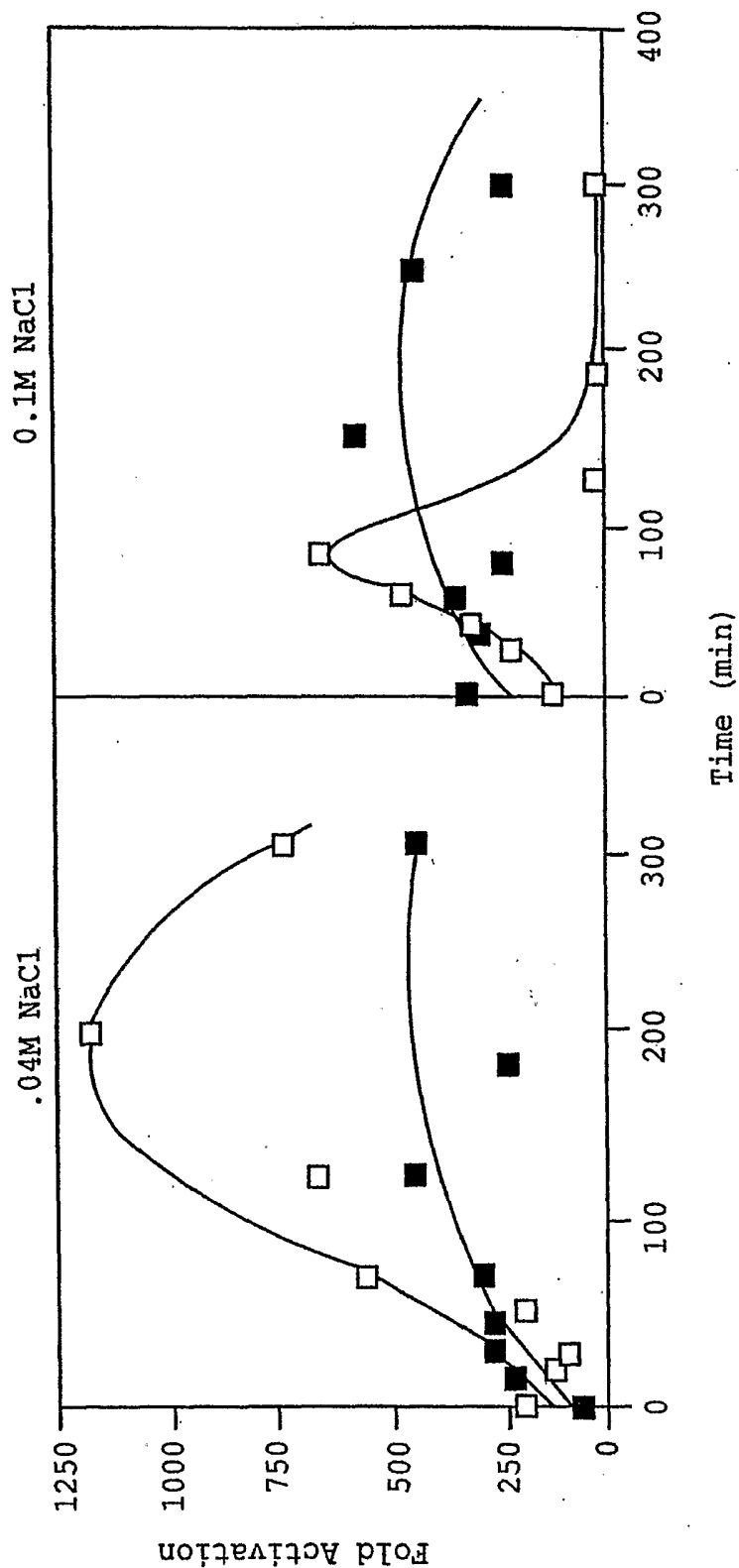

FIG. 9A

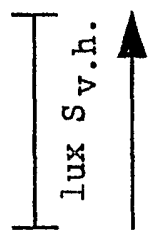
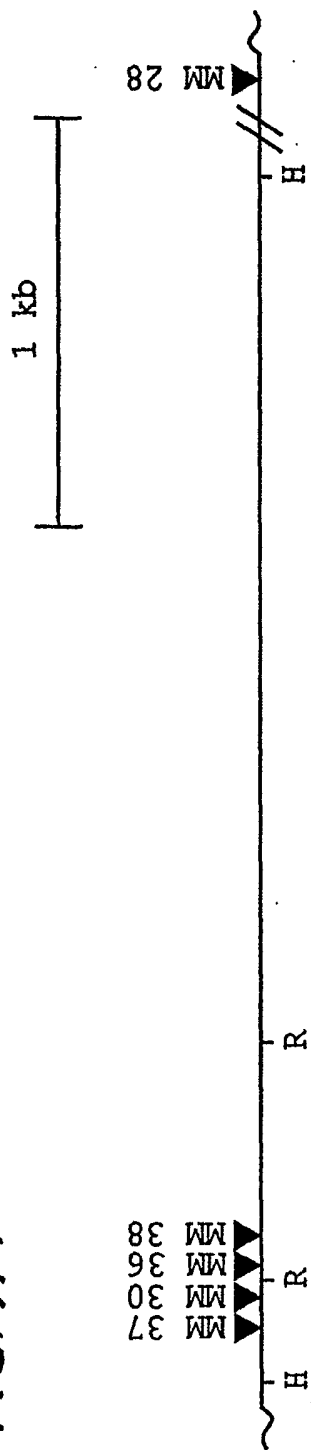

FIG. 9B

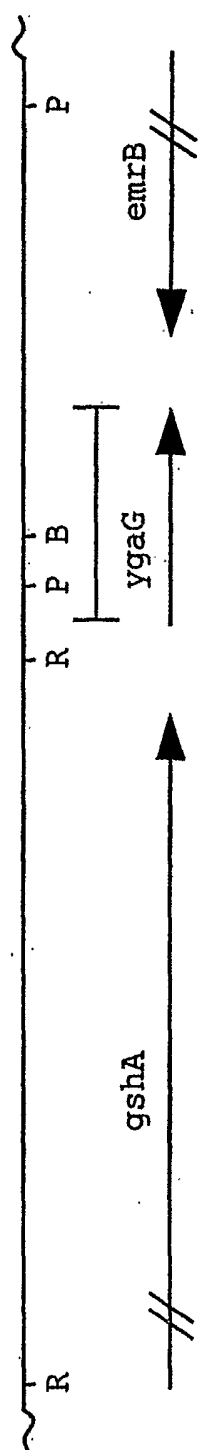

FIG. 10A

FIG. 10B

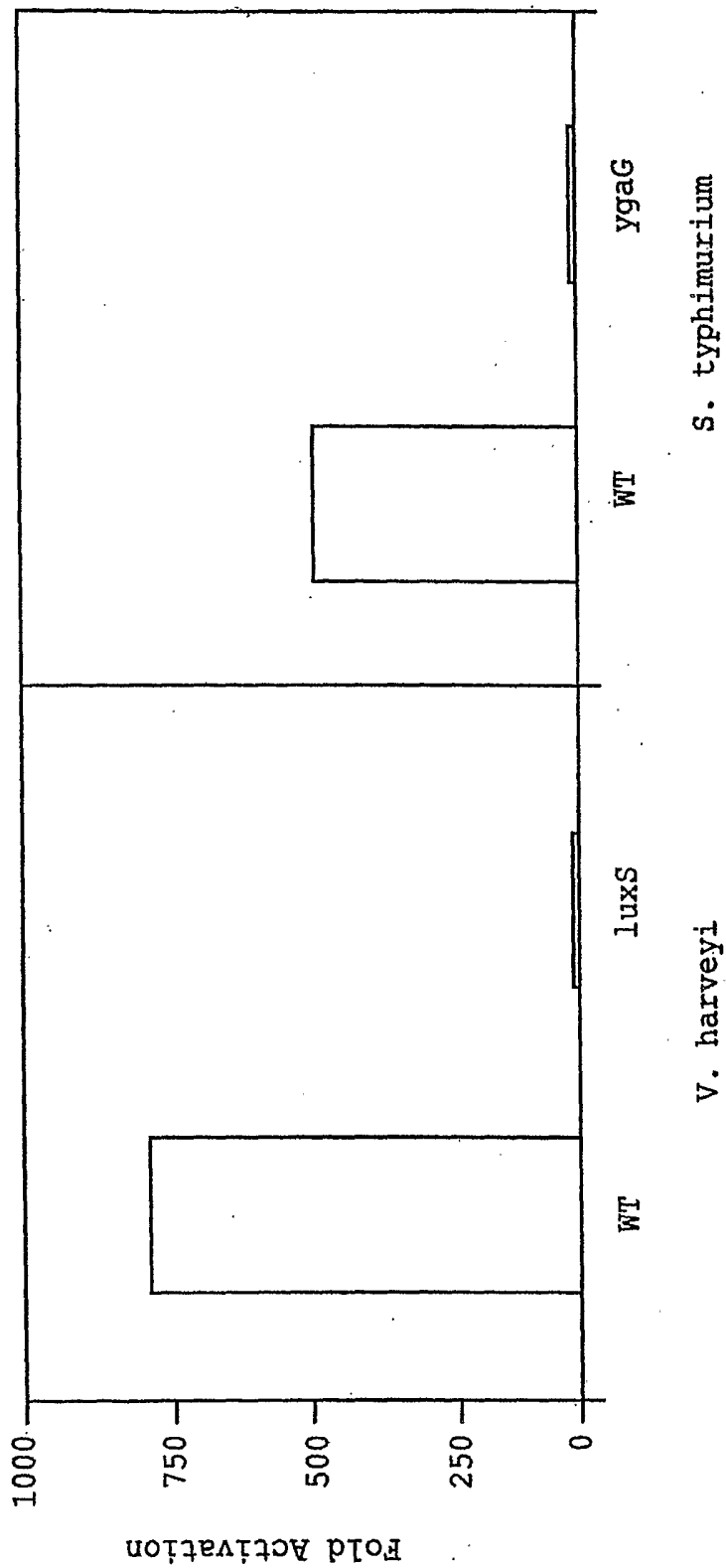
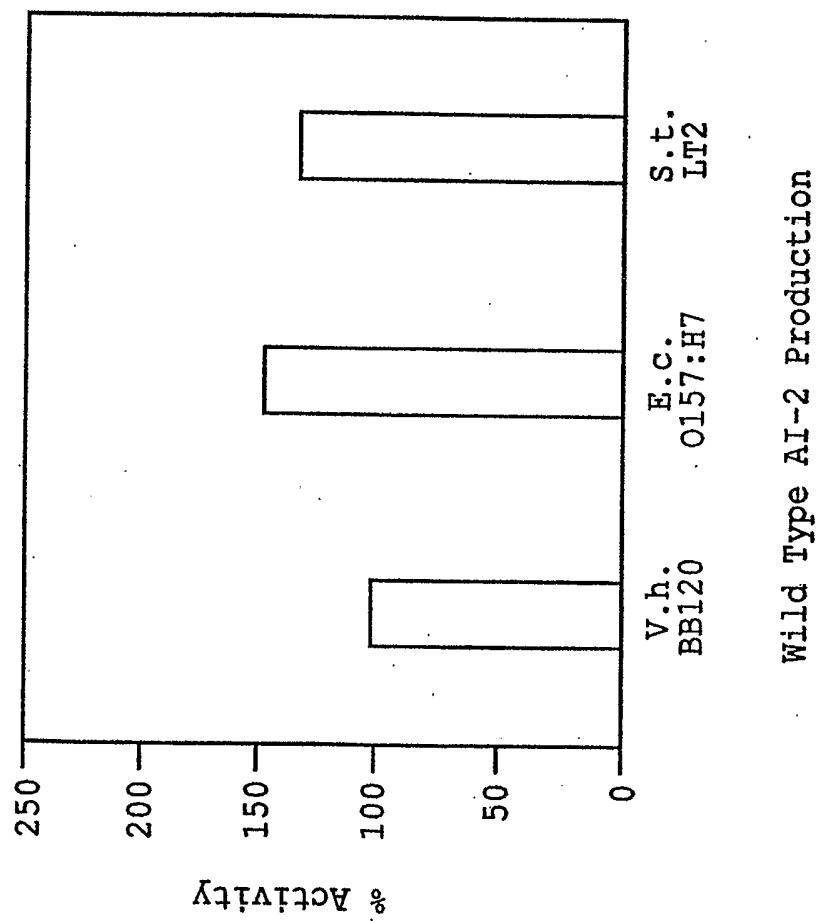

FIG. 11A



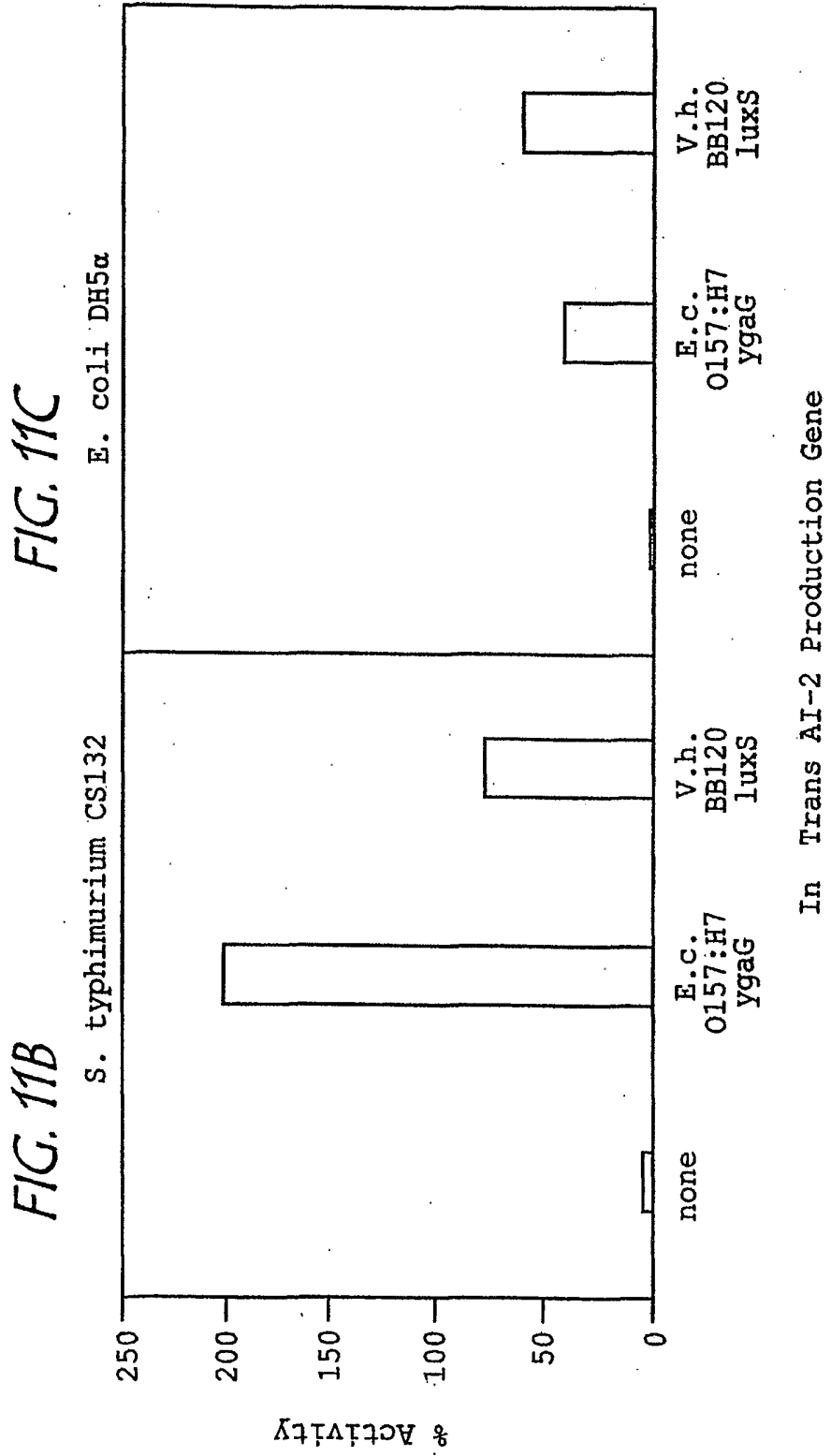
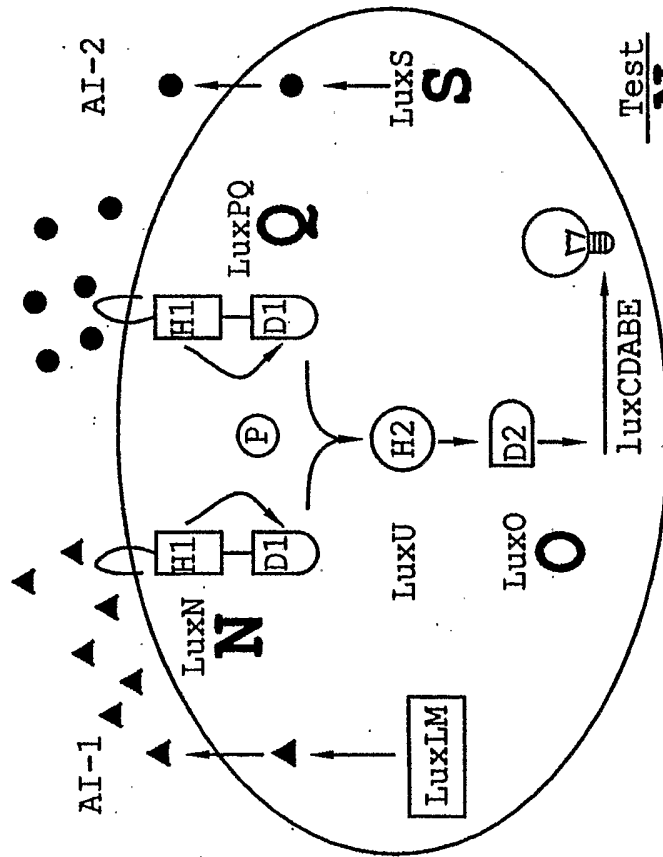

FIG. 12

V. h.	BB120	1	MPLLDSEFTVDHTRMAPAVRVAKTMQTPRGDTITVFDLRFAPNKDILSEKGIHTLEHLFAGFMRNHLNGSDSVIIDISPMGCRGTG
E. c.	MG1655	1	MPLLDSEFTVDHTRMEAPAVRVAKTMQTPMGDAITVFDLRFVCPNLEVM PERGIHTLEHLFAGFMRNHLNGV EIIDISPMGCRGTG
E. c.	0157:H7	1	MPLLDSEFTVDHTRMEAPAVRVAKTMQTPMGDAITVFDLRFVCPNLEVM PERGIHTLEHLFAGFMRNHLNGV EIIDISPMGCRGTG
S. t.	LT2	1	NSDHTRMQAPAVRVAKTMQTPMGDAITVFDLRFVCPNLEVM PERGIHTLEHLFAGFMRNHLNGV EIIDISPMGCRGTG
E. c.	DH5α	1	MPLLDSEFTVDHTRMEAPAVRVAKTMQTPMGDAITVFDLRFVCPNLEVM PERGIHTLEHLFAGFMRNHLNGV EIIDISPMGCRGTG
V. h.	BB120	87	FYMSLIGTSPKQOVADAWIAAMEDVLKVENQNKIPELNEYCCGTAA MHSLDEAKQIAKNI LEVGVAVNKNDLALPESMLRRLRID
E. c.	MG1655	87	FYMSLIGTDPKORVADAWKAAMEDVLKVQDONQIPELNVYCCGT YQMHSLQEAQDI ARSILERDVRINSNEELALPKKIQELHI
E. c.	0157:H7	87	FYMSLIGTDPKORVADVWKAAMEDVLKVQDONQIPELNVYCCGT YQMHSLQEAQDI ARSILERDVRINSNEELALPKKIQELHI
S. t.	LT2	87	FYMSLIGTDPKORVADAWKAAMADV LKVQDONQIP ELNVYCCGT YQMHSLSEAQDI ARHILERDVRVNSKELALPKKIQELHI
E. c.	DH5α	87	FYMSLIVRQMSVLLMPKGRQWKTC

FIG. 13

Hybrid quorum sensing circuit of *Vibrio harveyi*



<u>Test</u>	N	BB170	<u>Control</u>	Q	BB886
	SN	Double		O	JAF78

FIG. 14

Autoinducer Production and Response
Phenotypes of *V. harveyi* Lux mutants

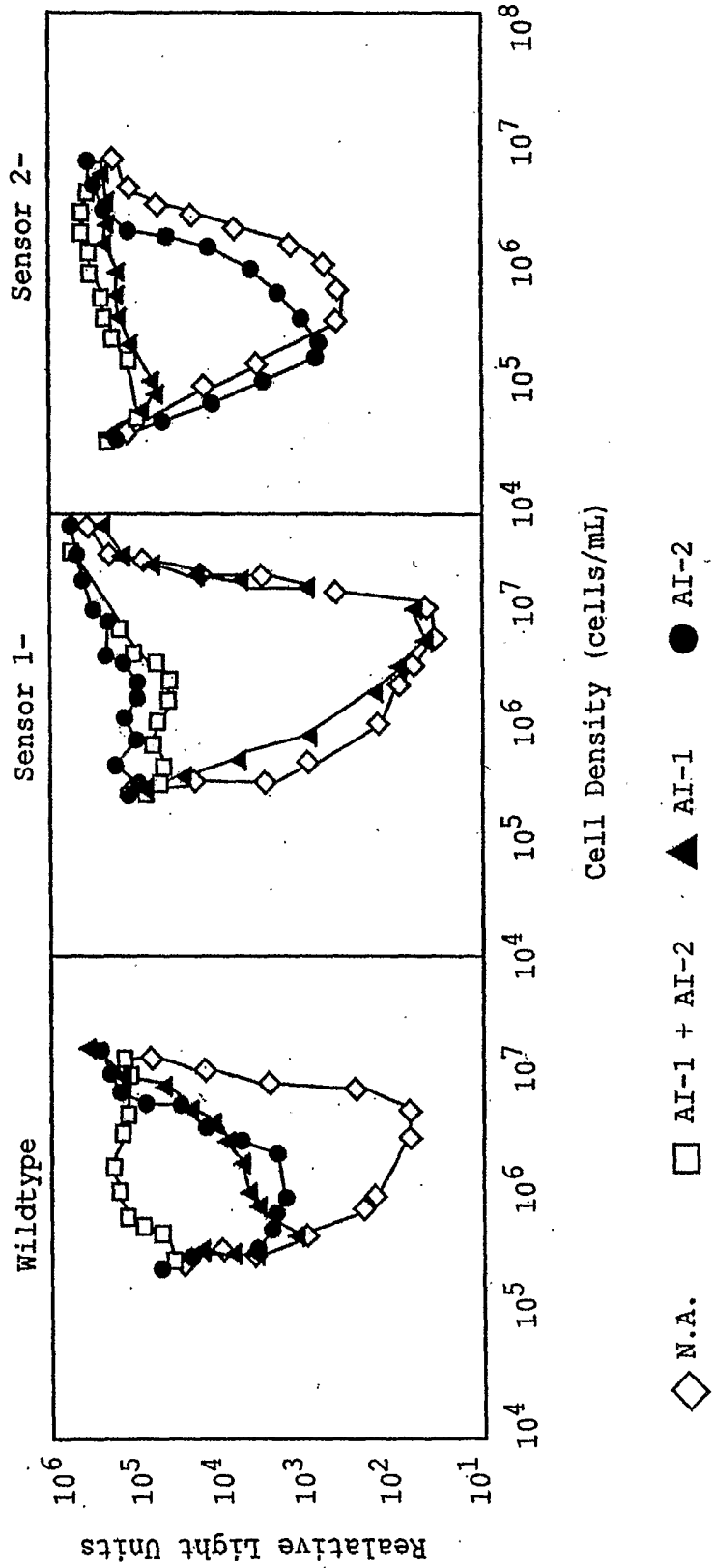

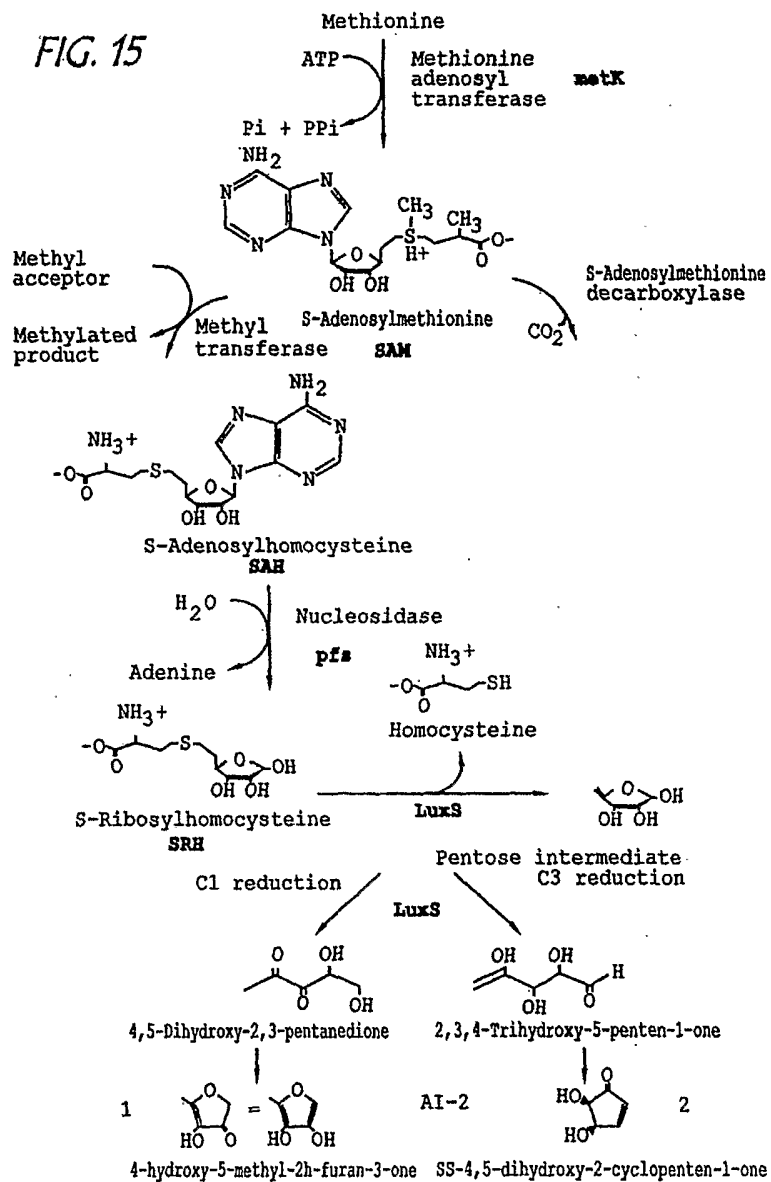

SEQUENCE LISTING

<110> PRINCETON UNIVERSITY
UNIVERSITY TECHNOLOGIES INTERNATIONAL, INC.
BASSLER, Bonnie L.
SURETTE, Michael G.

<120> COMPOSITIONS AND METHODS FOR REGULATING
BACTERIAL PATHOGENESIS

<130> PUNIV.001QPC

<150> US 10/387,345
<151> 2003-03-10

<160> 26

<170> FastSEQ for Windows Version 4.0

<210> 1
<211> 519
<212> DNA
<213> *Vibrio harveyi*

<400> 1
atgcctttat tagacagctt taccgtagac cacacgcgta tgaatgcacc agcggttcgt 60
gtggcetaaaa cgatgcaaac tccaaaagga gacaccatca cggatttcga cctacgtttc 120
actgctccaa acaaagacat cttttctgag aaaggaattc atacattaga gcatttgtac 180
gcaggcttta tgcgtaatca cctaaatggt gatagcgttg agatcattga tatctcacca 240
atgggggtgcc gtactggttt ctacatgagc ttgattggta cgccttcaga gcagcaagtg 300
gctgacgctt ggattgccgc gatggaagac gtactaaaag tagaaaacca aaacaagatc 360
cctgagttga acgaatacca atgtggtaca gcagcgtgc actctctgga tgaagcgaag 420
caaatcgcga agaacattct agaagtgggt gtggcgggtga ataagaatga tgaattggca 480
ctgccagagt caatgctgag agagctacgc atcgactaa 519

<210> 2
<211> 516
<212> DNA
<213> *Escherichia coli*

<400> 2
atgcccgttg tagatagctt cacagtcgat catacccga tggaaagcgc tgcagttcgg 60
gtggcgaaaa caatgaacac cccgcatggc gacgcaatca cgtgttcga tctgcgcttc 120
tgcgtgccga acaaagaagt gatgccagaa agagggatcc ataccctgga gcacctgttt 180
gctggtttta tgcgtaacca tcttaacggt aatgggtgag agattatcga tatctcgcca 240
atgggctgcc gcaccggtt ttatatgagt ctgattggtg cccagatga gcagcgtggt 300
gctgatgcct ggaaagcggc aatggaagac gtgctgaaag tgcaggatca gaatcagatc 360
ccggaactga acgtctacca gtgtggcact taccagatgc actcgttgca ggaagcgcag 420
gatattgcgc gtagcattct ggaacgtgac gtacgcatca acagcaacga agaactggca 480
ctgccgaaag agaagttgca ggaactgcac atctag 516

<210> 3
<211> 110
<212> DNA
<213> *Salmonella typhimurium*

<220>
 <221> misc_feature
 <222> (0)...(0)
 <223> sequence from MudJ

<400> 3
 gatgtgctga aagtgcagga tcaaaaccag atcccggagc tgaacgttta ccagtgcggg 60
 acgtatcaga tgcactcgct cagtgaagcg caggacattg cccgtcatat 110

<210> 4
 <211> 492
 <212> DNA
 <213> Salmonella typhimurium

<220>
 <221> misc_feature
 <222> (0)...(0)
 <223> sequence from alignment; starts with codon 8 and
 requires 3 frameshifts

<400> 4
 aattcggatc ataccggatg caagcgccgg cggtcggggt tgcaaaaacg atgaacaccc 60
 cgcattggcg cgcaatcacg tgtttgatct gcgtttttgc attccgaaca aagaagtgat 120
 gccggaaaaa gggattcata cgcttgagca tctgtttgct ggctttatgc gcgaccacct 180
 caacggtaac ggcgttgaga ttatcgatat ctgcgggatg ggctgcccga ccggctttta 240
 catgagcctg attggcacgc cggacgagca gcgtgttggc gacgcctgga aagcggcgat 300
 ggcgatgtg ctgaaagtgc aggatcaaaa ccagatcccg gagctgaacg tttaccagtg 360
 cggtagctat cagatgcact cgctcagtga agcgcaggac attgcccgtc atattctgga 420
 gcgtgatgtg cgcgtgaaca gcaataaaga gctggcgctg ccgaaagaaa aactgcagga 480
 actgatattt ag 492

<210> 5
 <211> 504
 <212> DNA
 <213> Haemophilus influenzae

<400> 5
 atgccattac ttgatagttt taaagtggat cacacaaaaa tgaacgcacc tgcagtacgc 60
 attgcaaaaa cgatgctcac gccaaaaggc gataatatta ctgtttttga tttacgtttt 120
 tgtattccaa acaaagaaat tctttcccca aaaggcattc atacacttga acatttattt 180
 gctggattta tgcgcatca ttaaatggc gatagcatag aaattattga tatttctccg 240
 atgggatgtc gcacgggatt ttatatgtct ttgattggca caccaaatga acagaaagtg 300
 tctgaggctt ggttagcttc aatgcaagat gttttaggtg tacaagatca agcttctatt 360
 cctgaattaa atatctatca atgcggaagc tatacggaac attccttaga agatgcacac 420
 gaaattgcc aaaaatgttat cgcacgaggc ataggtgtaa ataaaaatga agatttgtca 480
 ctcgataatt ccttattaa atag 504

<210> 6
 <211> 468
 <212> DNA
 <213> Helicobacter pylori

<400> 6
 atgaaaacac caaaaatgaa tgtagagagt ttaattttgg atcacaccaa agtcaaagcc 60
 ccttatgtgc gtgtcgctga tcgcaaaaag ggcgttaatg gggatttgat tgtcaaatatc 120
 gatgtgctgt tcaagcagcc caaccaagat cacatggaca tgcctagcct acattcttta 180

gagcatttag	tcgctgaaat	tatccgcaac	catgccagtt	atgtcgtgga	ttggtcgcct	240
atgggttgcc	aaacgggatt	ttatctcaca	gtgttaaacc	atgacaatta	cacagagatt	300
ttagaggttt	tagaaaagac	catgcaagat	gtgttaaagg	ctacagaagt	gcctgccagc	360
aatgaaaagc	aatgcggttg	ggcggctaac	cacactttag	agggtgctaa	ggatttagcg	420
cgcgcttttt	tagacaaaag	cgctgagtg	tctgaagtgg	gggtttga		468

<210> 7
 <211> 482
 <212> DNA
 <213> *Bacillus subtilis*

<400> 7						
atgccttcag	tagaaagttt	tgagottgat	cataatgagg	ttgttgctcc	atatgtaaga	60
cattgaggcg	tgcataaagt	gggaacagac	ggcgttgtaa	ataaatttga	cattcgtttt	120
tgccagccaa	ataaacaggc	gatgaagcct	gacaccattc	acacactcga	gcatttgctc	180
gcgtttacga	ttcgttctca	cgctgagaaa	tacgatcatt	ttgatatcat	tgatatttct	240
ccaatgggct	gccagacagg	ctattatcta	gttgtagcgg	gagagccgac	atcagcggaa	300
atcgttgatc	tgcttgaaga	cacaatgaag	gaagcggtag	agattacaga	aatacctgct	360
gcgaatgaaa	agcagtgcgg	ccaagcgaag	cttcatgata	tggaggcgcg	taaactttta	420
atgcgtttct	ggctttcaca	ggataaagaa	gaattgctaa	aagtatttgg	ctaaaataga	480
aa						482

<210> 8
 <211> 537
 <212> DNA
 <213> *Borrelia burdorferi*

<400> 8						
atgaatttga	atgggaaaaa	ttagattttg	taaaaaaaaa	acaaacagcg	ctaaaaaaaaa	60
gaaaaaaaaa	acaagcttta	caatagatca	tacaaaactc	aaccctggca	tatatgtctc	120
aagaaaagat	acctttgaaa	atgtaatatt	tactacaata	gacattagaa	tcaaagctcc	180
caacatcgaa	ccaataattg	aaaacgcagc	aatacataca	atagagcaca	taggagctac	240
tttacttaga	aataatgaag	tttggaccga	aaaaatagta	tattttggcc	ctatgggatg	300
cagaactggt	ttttacttaa	taatttttgg	agactatgaa	agtaaagatc	ttgttgactt	360
agtctcatgg	cttttttccg	aaatcgtaaa	tttttcagaa	cctatcccag	gcgcaagtga	420
taaggaatgc	ggaaattaca	aagaacataa	ccttgatatg	gctaaatatg	aatcttctaa	480
atacttacia	atattaaaca	atattaaaga	agaaaattta	aaatatcctt	agctcat	537

<210> 9
 <211> 519
 <212> DNA
 <213> *Vibrio cholerae*

<400> 9						
atgccattat	tagacagttt	taccgtcgat	catactcgta	tgaatgcacc	ggcgggtcgt	60
gttgccaaaa	ccatgcaaac	cccaaaagg	gatacgatta	cogtatttga	tttgcgtttt	120
actatgccaa	acaaagatat	cttgtctgag	cgcggtatcc	atactctaga	gcatctctac	180
gcgggcttta	tgcgcaatca	ccttaacggc	agccaagtgg	agatcatcga	tatttcacca	240
atgggttgcc	gtacaggttt	ctacatgagc	ttgattgggtg	cgccgacaga	acagcaagtg	300
gcacaagcat	ggctagccgc	aatgcaagat	gtgttgaaag	ttgaaagcca	agagcaaatt	360
cctgagctga	atgagtacca	gtgcggcact	gcggcgatgc	actcgtcga	agaagccaaa	420
gcgattgcga	aaaacgtgat	tgcggcaggc	atctcgttta	accgtaacga	tgagttggcg	480
ctgcccgaat	ctatgctcaa	tgagctgaag	gttcaactaa			519

<210> 10
 <211> 172
 <212> PRT

<213> *Vibrio harveyi*

<400> 10

```

Met Pro Leu Leu Asp Ser Phe Thr Val Asp His Thr Arg Met Asn Ala
 1          5          10          15
Pro Ala Val Arg Val Ala Lys Thr Met Gln Thr Pro Lys Gly Asp Thr
          20          25          30
Ile Thr Val Phe Asp Leu Arg Phe Thr Ala Pro Asn Lys Asp Ile Leu
 35          40          45
Ser Glu Lys Gly Ile His Thr Leu Glu His Leu Tyr Ala Gly Phe Met
 50          55          60
Arg Asn His Leu Asn Gly Asp Ser Val Glu Ile Ile Asp Ile Ser Pro
 65          70          75
Met Gly Cys Arg Thr Gly Phe Tyr Met Ser Leu Ile Gly Thr Pro Ser
          85          90
Glu Gln Gln Val Ala Asp Ala Trp Ile Ala Ala Met Glu Asp Val Leu
          100          105          110
Leu Val Glu Asn Gln Asn Lys Ile Pro Glu Leu Asn Glu Tyr Gln Cys
          115          120          125
Gly Thr Ala Ala Met His Ser Leu Asp Glu Ala Lys Gln Ile Ala Lys
          130          135          140
Asn Ile Leu Glu Val Gly Val Ala Val Asn Lys Asn Asp Glu Leu Ala
 145          150          155          160
Leu Pro Glu Ser Met Leu Arg Glu Leu Arg Ile Asp
          165          170

```

<210> 11

<211> 171

<212> PRT

<213> *Escherichia coli*

<400> 11

```

Met Pro Leu Leu Asp Ser Phe Thr Val Asp His Thr Arg Met Glu Ala
 1          5          10          15
Pro Ala Val Arg Val Ala Lys Thr Met Asn Thr Pro His Gly Asp Ala
          20          25          30
Ile Thr Val Phe Asp Leu Arg Phe Cys Val Pro Asn Lys Glu Val Met
 35          40          45
Pro Glu Arg Gly Ile His Thr Leu Glu His Leu Phe Ala Gly Phe Met
 50          55          60
Arg Asn His Leu Asn Gly Asn Gly Val Glu Ile Ile Asp Ile Ser Pro
 65          70          75
Met Gly Cys Ala Thr Gly Phe Tyr Met Ser Leu Ile Gly Thr Pro Asp
          85          90
Glu Gln Arg Val Ala Asp Ala Trp Lys Ala Ala Met Glu Asp Val Leu
          100          105          110
Lys Val Gln Asp Gln Asn Gln Ile Pro Glu Leu Asn Val Tyr Gln Cys
          115          120          125
Gly Thr Tyr Gln Met His Ser Leu Gln Glu Ala Gln Asp Ile Ala Arg
          130          135          140
Ser Ile Leu Glu Arg Asp Val Arg Ile Asn Ser Asn Glu Glu Leu Ala
 145          150          155          160
Leu Pro Lys Glu Lys Leu Gln Glu Leu His Ile
          165          170

```

<210> 12

<211> 164

<212> PRT

<213> Salmonella typhimurium

<220>

<221> VARIANT

<222> (0)...(0)

<223> starts with residue 8 and has 3 frameshifts

<400> 12

```

Asn Ser Asp His Thr Arg Met Gln Ala Pro Ala Val Arg Val Ala Lys
 1          5          10          15
Thr Met Asn Thr Pro His Gly Asp Ala Ile Thr Val Phe Asp Leu Arg
 20          25          30
Phe Cys Ile Pro Asn Lys Glu Val Met Pro Glu Lys Gly Ile His Thr
 35          40          45
Leu Glu His Leu Phe Ala Gly Phe Met Arg Asp His Leu Asn Gly Asn
 50          55          60
Gly Val Glu Ile Ile Asp Ile Ser Pro Met Gly Cys Arg Thr Gly Phe
 65          70          75          80
Tyr Met Ser Leu Ile Gly Thr Pro Asp Glu Gln Arg Val Ala Asp Ala
 85          90          95
Trp Leu Ala Ala Met Ala Asp Val Leu Lys Val Gln Asp Gln Asn Gln
 100         105         110
Ile Pro Glu Leu Asn Val Tyr Gln Cys Gly Thr Tyr Gln Met His Ser
 115         120         125
Leu Ser Glu Ala Gln Asp Ile Ala Arg His Ile Leu Glu Arg Asp Val
 130         135         140
Arg Val Asn Ser Asn Lys Glu Leu Ala Leu Pro Lys Glu Lys Leu Gln
 145         150         155         160
Glu Thr Asp Ile
    
```

<210> 13

<211> 167

<212> PRT

<213> Haemophilus influenzae

<400> 13

```

Met Pro Leu Leu Asp Ser Phe Lys Val Asp His Thr Lys Met Asn Ala
 1          5          10          15
Pro Ala Val Arg Ile Ala Lys Thr Met Leu Thr Pro Lys Gly Asp Asn
 20          25          30
Ile Thr Val Phe Asp Leu Arg Phe Cys Ile Pro Asn Lys Glu Ile Leu
 35          40          45
Ser Pro Lys Gly Ile His Thr Leu Glu His Leu Phe Ala Gly Phe Met
 50          55          60
Arg Asp His Leu Asn Gly Asp Ser Ile Glu Ile Ile Asp Ile Ser Pro
 65          70          75          80
Met Gly Cys Arg Thr Gly Phe Tyr Met Ser Leu Ile Gly Thr Pro Asn
 85          90          95
Glu Gln Lys Val Ser Glu Ala Trp Leu Ala Ser Met Gln Asp Val Leu
 100         105         110
Gly Val Gln Asp Gln Ala Ser Ile Pro Glu Leu Asn Ile Tyr Gln Cys
 115         120         125
Gly Ser Tyr Thr Glu His Ser Leu Glu Asp Ala His Glu Ile Ala Lys
 130         135         140
Asn Val Ile Ala Arg Gly Ile Gly Val Asn Lys Asn Glu Asp Leu Ser
    
```

<210> 16
 <211> 173
 <212> PRT
 <213> *Borrelia burgdorferi*

<400> 16
 Met Gly Lys Ile Arg Phe Cys Lys Lys Asn Thr Asn Ser Ala Lys Lys
 1 5 10 15
 Met Lys Leu Ile Thr Ser Phe Thr Ile Asp His Thr Lys Leu Asn Pro
 20 25 30
 Gly Ile Tyr Val Ser Arg Lys Asp Thr Phe Glu Asn Val Ile Phe Thr
 35 40 45
 Thr Ile Asp Ile Arg Ile Lys Ala Pro Asn Ile Glu Pro Ile Ile Glu
 50 55 60
 Asn Ala Ala Ile His Thr Ile Glu His Ile Gly Ala Thr Leu Leu Arg
 65 70 75 80
 Asn Asn Glu Val Trp Thr Glu Lys Ile Val Tyr Phe Gly Pro Met Gly
 85 90 95
 Cys Arg Thr Gly Phe Tyr Leu Ile Ile Phe Gly Asp Tyr Glu Ser Lys
 100 105 110
 Asp Leu Val Asp Leu Val Ser Trp Leu Phe Ser Glu Ile Val Asn Phe
 115 120 125
 Ser Glu Pro Ile Pro Gly Ala Ser Asp Lys Glu Cys Gly Asn Tyr Lys
 130 135 140
 Glu His Asn Leu Asp Met Ala Lys Tyr Glu Ser Ser Lys Leu Tyr Gln
 145 150 155 160
 Ile Leu Asn Asn Ile Lys Glu Glu Asn Leu Lys Tyr Pro
 165 170

<210> 17
 <211> 172
 <212> PRT
 <213> *Vibrio cholerae*

<400> 17
 Met Pro Leu Leu Asp Ser Phe Thr Val Asp His Thr Arg Met Asn Ala
 1 5 10 15
 Pro Ala Val Arg Val Ala Lys Thr Met Gln Thr Pro Lys Gly Asp Thr
 20 25 30
 Ile Thr Val Phe Asp Leu Arg Phe Thr Met Pro Asn Lys Asp Ile Leu
 35 40 45
 Ser Glu Arg Gly Ile His Thr Leu Glu His Leu Tyr Ala Gly Phe Met
 50 55 60
 Arg Asn His Leu Asn Gly Ser Gln Val Glu Ile Ile Asp Ile Ser Pro
 65 70 75 80
 Met Gly Cys Arg Thr Gly Phe Tyr Met Ser Leu Ile Gly Ala Pro Thr
 85 90 95
 Glu Gln Gln Val Ala Gln Ala Trp Leu Ala Ala Met Gln Asp Val Leu
 100 105 110
 Lys Val Glu Ser Gln Glu Gln Ile Pro Glu Leu Asn Glu Tyr Gln Cys
 115 120 125
 Gly Thr Ala Ala Met His Ser Leu Glu Glu Ala Lys Ala Ile Ala Lys
 130 135 140
 Asn Val Ile Ala Ala Gly Ile Ser Val Asn Arg Asn Asp Glu Leu Ala
 145 150 155 160
 Leu Pro Glu Ser Met Leu Asn Glu Leu Lys Val His

165

170

<210> 18
 <211> 111
 <212> PRT
 <213> Escherichia coli

<400> 18
 Met Pro Leu Leu Asp Ser Phe Thr Val Asp His Thr Arg Met Glu Ala
 1 5 10 15
 Pro Ala Val Arg Val Ala Lys Thr Met Asn Thr Pro His Gly Asp Ala
 20 25 30
 Ile Thr Val Phe Asp Leu Arg Phe Cys Val Pro Asn Lys Glu Val Met
 35 40 45
 Pro Glu Arg Gly Ile His Thr Leu Glu His Leu Phe Ala Gly Phe Met
 50 55 60
 Arg Asn His Leu Asn Gly Asn Gly Val Glu Ile Ile Asp Ile Ser Pro
 65 70 75 80
 Met Gly Cys Ala Thr Gly Phe Tyr Met Ser Leu Leu Val Arg Gln Met
 85 90 95
 Ser Ser Val Leu Leu Met Pro Gly Lys Arg Gln Trp Lys Thr Cys
 100 105 110

<210> 19
 <211> 32
 <212> DNA
 <213> Artificial Sequence

<220>

<223> Aritificial Primer

<400> 19
 cggagatctg cgctttcaat ggataaacta cg 32

<210> 20
 <211> 30
 <212> DNA
 <213> Artificial Sequence

<220>

<223> Aritificial Primer

<400> 20
 cgcgatcct cttcttcgct gtttcgctg 30

<210> 21
 <211> 36
 <212> DNA
 <213> Artificial Sequence

<220>

<223> Aritificial Primer

<221> misc_feature
 <222> 30...39
 <223> n = a,t,g or c

<400> 21
 ggccacgcgt cgactagtac nnnnnnnnnn acgccc 36

<210> 22
 <211> 21
 <212> DNA
 <213> Artificial Sequence

<220>

<223> Aritificial Primer

<400> 22
 gcactacagg cttgcaagcc c 21

<210> 23
 <211> 20
 <212> DNA
 <213> Artificial Sequence

<220>

<223> Aritificial Primer

<400> 23
 ggccacgcgt cgactagtca 20

<210> 24
 <211> 20
 <212> DNA
 <213> Artificial Sequence

<220>

<223> Aritificial Primer

<400> 24
 tctaattcca tcagatcccg 20

<210> 25
 <211> 25
 <212> DNA
 <213> Artificial Sequence

<220>

<223> Aritificial Primer

<400> 25
 gtgaagcttg tttactgact agatc 25

<210> 26
<211> 25
<212> DNA
<213> Artificial Sequence

<220>

<223> Aritificial Primer

<400> 26
gtgtctagaa aaacacgcct gacag

25