

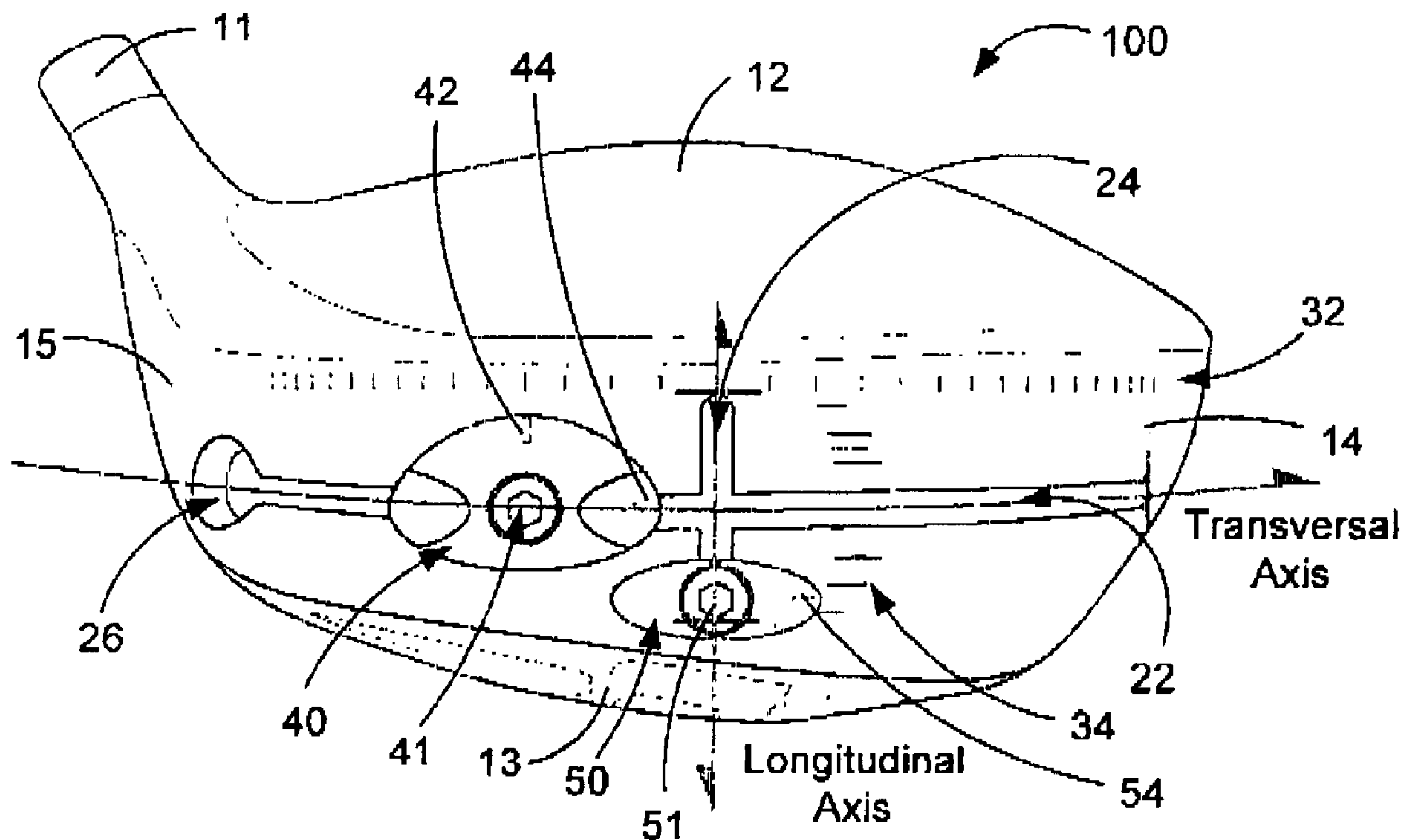

(86) Date de dépôt PCT/PCT Filing Date: 2007/03/09
 (87) Date publication PCT/PCT Publication Date: 2007/09/13
 (85) Entrée phase nationale/National Entry: 2009/09/09
 (86) N° demande PCT/PCT Application No.: CA 2007/000387
 (87) N° publication PCT/PCT Publication No.: 2007/101350
 (30) Priorité/Priority: 2006/03/09 (US60/780,344)

(51) Cl.Int./Int.Cl. *A63B 69/00* (2006.01),
A63B 53/04 (2006.01), *A63B 59/00* (2006.01),
A63B 69/36 (2006.01), *A63B 69/38* (2006.01)
 (71) Demandeur/Applicant:
 CASATI, ETTORE, CA
 (72) Inventeur/Inventor:
 CASATI, ETTORE, CA
 (74) Agent: BCF LLP

(54) Titre : ARTICLE DE SPORT A CONFIGURATION DE POIDS AJUSTABLE
 (54) Title: SPORTING ARTICLE WITH ADJUSTABLE WEIGHT CONFIGURATION



(57) Abrégé/Abstract:

A sporting article having moveable weight members of various weight values that may be positioned along a guide in various configurations, for example, transversally, longitudinally and/or diagonally, at various positions and angles on the sporting article so that the user may properly adjust the weight distribution of the sporting article to perform a desired shot or improve maneuverability.

(12) INTERNATIONAL APPLICATION PUBLISHED UNDER THE PATENT COOPERATION TREATY (PCT)

(19) World Intellectual Property Organization
International Bureau



(43) International Publication Date
13 September 2007 (13.09.2007)

PCT

(10) International Publication Number
WO 2007/101350 A1

(51) International Patent Classification:

A63B 69/00 (2006.01) A63B 69/36 (2006.01)
A63B 53/04 (2006.01) A63B 69/38 (2006.01)
A63B 59/00 (2006.01)

(21) International Application Number:

PCT/CA2007/000387

(22) International Filing Date: 9 March 2007 (09.03.2007)

(25) Filing Language: English

(26) Publication Language: English

(30) Priority Data:

60/780,344 9 March 2006 (09.03.2006) US

(71) Applicant (for all designated States except US): **POWER GOLF CORPORATION** [CA/CA]; 9620 Ignace, Unit P, Brossard, Québec J4Y 2R4 (CA).

(72) Inventor; and

(75) Inventor/Applicant (for US only): **CASATI, Ettore** [CA/CA]; 8390 Racine, Brossard, Québec J4X 1T8 (CA).

(74) Agents: **VOULOUMANOS, Tom et al.**; BCF LLP, 1100 René-Lévesque Blvd. West, 25th Floor, Montréal, Québec H3B 5C9 (CA).

(81) Designated States (unless otherwise indicated, for every kind of national protection available): AE, AG, AL, AM, AT, AU, AZ, BA, BB, BG, BR, BW, BY, BZ, CA, CH, CN, CO, CR, CU, CZ, DE, DK, DM, DZ, EC, EE, EG, ES, FI, GB, GD, GE, GH, GM, GT, HN, HR, HU, ID, IL, IN, IS, JP, KE, KG, KM, KN, KP, KR, KZ, LA, LC, LK, LR, LS, LT, LU, LY, MA, MD, MG, MK, MN, MW, MX, MY, MZ, NA, NG, NI, NO, NZ, OM, PG, PH, PL, PT, RO, RS, RU, SC, SD, SE, SG, SK, SL, SM, SV, SY, TJ, TM, TN, TR, TT, TZ, UA, UG, US, UZ, VC, VN, ZA, ZM, ZW.

(84) Designated States (unless otherwise indicated, for every kind of regional protection available): ARIPO (BW, GH, GM, KE, LS, MW, MZ, NA, SD, SL, SZ, TZ, UG, ZM, ZW), Eurasian (AM, AZ, BY, KG, KZ, MD, RU, TJ, TM), European (AT, BE, BG, CH, CY, CZ, DE, DK, EE, ES, FI, FR, GB, GR, HU, IE, IS, IT, LT, LU, LV, MC, MT, NL, PL, PT, RO, SE, SI, SK, TR), OAPI (BF, BJ, CF, CG, CI, CM, GA, GN, GQ, GW, ML, MR, NE, SN, TD, TG).

Published:

— with international search report

For two-letter codes and other abbreviations, refer to the "Guidance Notes on Codes and Abbreviations" appearing at the beginning of each regular issue of the PCT Gazette.

(54) Title: SPORTING ARTICLE WITH ADJUSTABLE WEIGHT CONFIGURATION

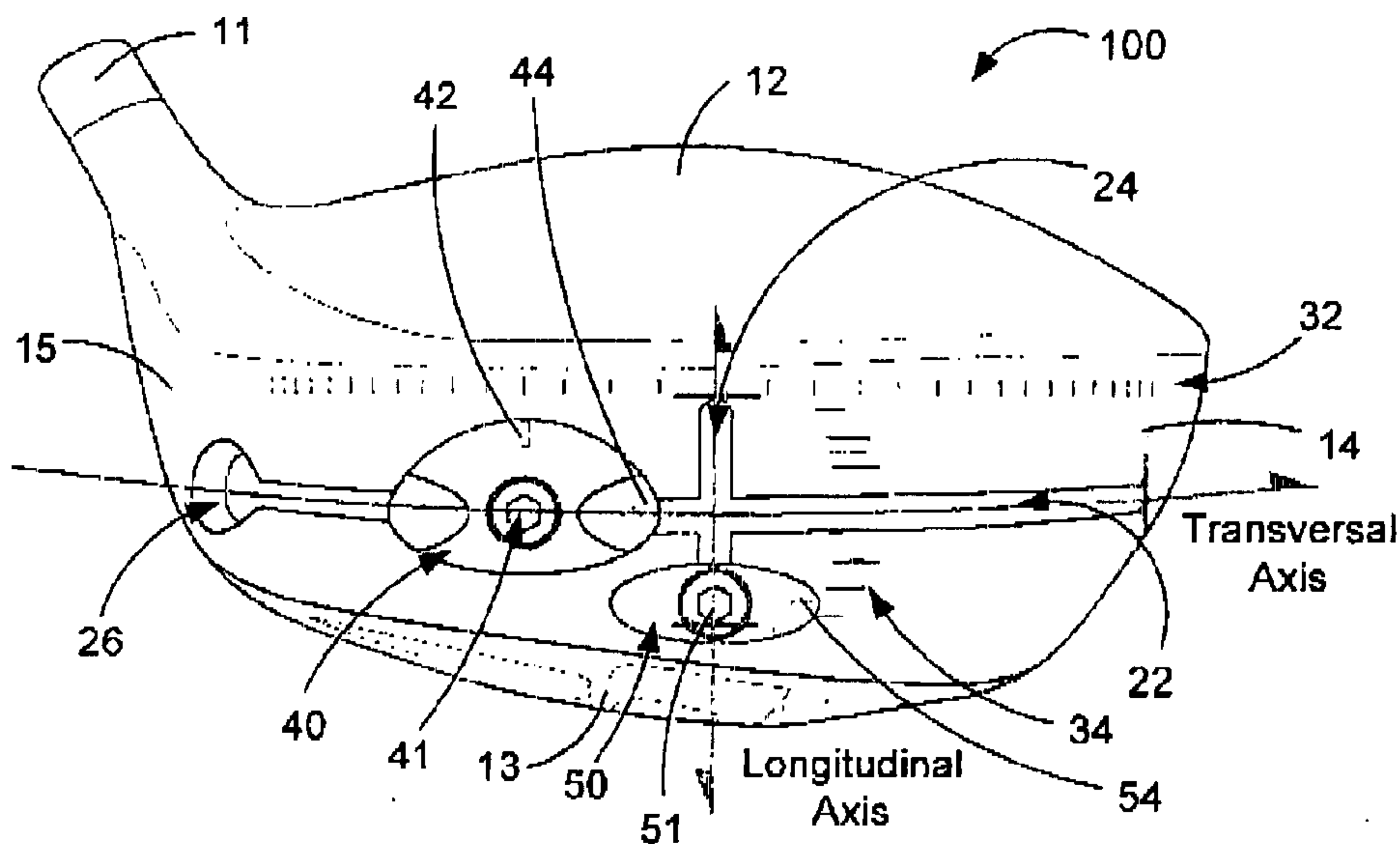

(57) Abstract: A sporting article having moveable weight members of various weight values that may be positioned along a guide in various configurations, for example, transversally, longitudinally and/or diagonally, at various positions and angles on the sporting article so that the user may properly adjust the weight distribution of the sporting article to perform a desired shot or improve maneuverability.

WO 2007/101350 A1

SPORTING ARTICLE WITH ADJUSTABLE WEIGHT CONFIGURATION**CROSS-REFERENCE TO RELATED APPLICATION**

[0001] The present application claims the benefits of U.S. provisional patent application No. 60/780,344 filed March 9, 2006, which is hereby incorporated by reference.

TECHNICAL FIELD

[0002] The present invention relates to a sporting article with an adjustable weight configuration. More specifically, the present invention relates to a golf club head with an adjustable weight configuration.

BACKGROUND

[0003] When practicing sports, the weight balance of a sporting article may have an impact on the performance of the user, be the sporting article be a golf club, racket, a hockey stick, a ski, etc.

[0004] For example, when swinging a golf club at a golf ball, some golfers have a swing such that the heel portion of the golf club head tends to move faster than the toe portion. This results in the heel portion arriving ahead of the toe portion at impact, causing the impact surface to be misoriented. This is what is commonly referred to as a "slice". Conversely, some golfers have a swing such that the toe portion of the golf club head tends to move faster than the heel portion. This results in the toe portion arriving ahead of the heel portion at impact, causing the impact surface to be misoriented. This is what is commonly referred to as a "hook".

[0005] Thus, golf club heads are configured in a variety of geometries in order to move the weight of the golf club head to points that enhance stability, i.e. more weight at either the heel or toe portion slows down that portion during the swing. These points differ from one model of golf club to another.

[0006] While common golf clubs operate satisfactorily, most of the weighted golf club heads suffer from the limitation that their weight distribution cannot be readily altered to customize the golf club to the needs of a particular golfer. Other sporting articles suffer from

SUMMARY

[0007] The present invention relates a sporting article comprising at least one body portion providing a guide, the at least one body portion defining a generally longitudinal length, a generally transversal length and a generally diagonal length thereof, the guide comprising at least two guide sections, and at least one moveable weight member for being moveably engaged to the guide. Each of the guide sections providing for selectively moving the moveable weight member along at least one of the generally longitudinal, generally transversal and generally diagonal lengths of the at least one body portion.

[0008] The present invention also relates to a sporting article comprising a guide channel formed within at least one body portion of the sporting article and at least one moveable weight member for being moveably engaged within the guide channel. The moveable weight member comprises an external element for being positioned externally relative to the guide channel, an internal element for being positioned within the guide channel and an intermediate element for mounting the external and internal elements thereon near opposite ends thereof. When mounting the moveable weight member to the guide channel, selective actuation of the intermediate element provides for moving the external and internal elements closer to one another along the intermediate element causing the external and internal elements to respectively frictionally abut an external surface the body portion and an internal surface of the guide channel thereby locking the moveable weight member at a given position along the guide channel.

[0009] The present invention further relates to a sporting article comprising a guide provided on at least one body portion of the sporting article, positioning indicators being provided on the at least one body portion along the guide and at least one moveable weight member for being moveably mounted to the guide. The moveable weight member being configured to be lockingly positioned at a desired position indicated by a given positioning indicators along the guide.

[0010] The present invention further still relates to a weight member for a sporting article having a guide channel formed within at least one body portion thereof, the weight member being moveably engaged within the guide channel. The weight member comprising an external element for being positioned externally relative to the guide channel, an internal element for being positioned within the guide channel and an intermediate element for mounting the external and internal elements thereon near opposite ends thereof. When engaging the weight member to the guide channel, selective actuation of the intermediate element provides for moving the external and internal elements closer to one another along the intermediate element causing the external and internal elements to respectively frictionally abut an external surface the body portion and an internal surface of the guide channel thereby locking the weight member at a given position along the guide channel.

BRIEF DESCRIPTION OF THE DRAWINGS

[0011] Non-limitative illustrative embodiments of the invention will now be described by way of examples only with reference to the accompanying drawings, in which:

[0012] Figure 1 is a back view of a golf club head provided with an adjustable weight configuration according to a first embodiment of the present invention;

[0013] Figure 2 is a top view of the golf club head of Figure 1;

[0014] Figure 3A is a cross sectional view of a first embodiment of a moveable weight member and a corresponding guide section in an unlocked position;

[0015] Figure 3B is a cross sectional view of the moveable weight member and corresponding guide section of Figure 3A in a locked position;

[0016] Figure 4A is a cross sectional view of a second embodiment of a moveable weight member and a corresponding guide section in an unlocked position;

[0017] Figure 4B is a cross sectional view of the moveable weight member and corresponding guide section of Figure 4A in a locked position;

[0018] Figure 5A is a cross sectional view of a third embodiment of a moveable weight member and a corresponding guide section in an unlocked position;

[0019] Figure 5B is a cross sectional view of the moveable weight member and corresponding guide section of Figure 5A in a locked position;

[0020] Figure 6 is a toe side view of the golf club head of Figure 1;

[0021] Figure 7 is a back view of the golf club head of Figure 1 with the adjustable weight configuration disposed in a first sample configuration; and

[0022] Figure 8 is a back view of the golf club head of Figure 1 with the adjustable weight configuration disposed in a second sample configuration.

[0023] Figure 9 is a back view of a golf club head provided with an adjustable weight configuration according to a second embodiment of the present invention;

[0024] Figure 10 is a back view of a golf club head provided with an adjustable weight configuration according to a third embodiment of the present invention;

[0025] Figure 11 is a back view of a golf club head provided with an adjustable weight configuration according to a fourth embodiment of the present invention;

[0026] Figure 12 is a back view of a golf club head provided with an adjustable weight configuration according to a fifth embodiment of the present invention;

[0027] Figure 13 is a front view of a racket provided with an adjustable weight configuration according to a sixth embodiment of the present invention;

[0028] Figure 14 is a side view of the racket of Figure 13;

[0029] Figure 15 is a front view of a hockey stick provided with an adjustable weight configuration according to a seventh embodiment of the present invention;

[0030] Figure 16 is a top view of a ski provided with an adjustable weight configuration according to an eight embodiment of the present invention; and

[0031] Figure 17 is a top view of a ski provided with an adjustable weight configuration according to a ninth embodiment of the present invention.

DETAILED DESCRIPTION

[0032] Generally stated, the illustrative embodiments of the present invention provide sporting articles for users of all calibers; from amateur to professional. The present invention allows the user to adjust the weight distribution of the sporting article in order to customize it to his or her particular needs. Moveable weight members of various weight values may be

positioned along a guide in various configurations, for example, transversally, longitudinally and/or diagonally, at various positions and angles on the sporting article so that the user may properly adjust the weight distribution of the sporting article to perform a desired shot or improve maneuverability.

[0033] Referring to Figures 1 and 2, there is shown an example of a sporting article in the form of a golf club head 100 having a hosel 11, to connect the golf club head 100 to a golf club shaft (not shown), a crown portion 12, a sole portion 13, a toe portion 14, a heel portion 15, a face portion 16 with an impact surface 17 and a rear portion 18. In the illustrated embodiment, the golf club head 100 includes two moveable weight members 40 and 50, which may be positioned in various configurations along transversal 22 and longitudinal 24 guide sections. It is to be understood that in alternative embodiments the number of moveable weight members may vary as well as the number of transversal and longitudinal guide sections, and may also include diagonal guide sections.

[0034] Furthermore, in this particular example the illustrated golf club head 100 is that of a driver. However, it is to be understood that the adjustable weight configuration may be applied to any other type of golf club head such as, for example, irons, wedges (pitching (pw), gap (gw), sand (sw), lobe (lw)) or a putter, made of whatever type of material.

[0035] The first moveable weight member 40 is generally displaced along the transversal guide section 22, which runs on the rear portion 18 of the golf club head 100 from its toe portion 14 to its heel portion 15, while the second moveable weight member 50 is generally displaced along the longitudinal guide section 24, which runs on the rear portion 18 of the golf club head 100 from its crown portion 12 to its sole portion 13. It is to be understood, however, that both moveable weight members 40 and 50 may be displaced along either or both the transversal guide section 22 and the longitudinal guide section 24.

[0036] The moveable weight members 40 and 50 typically weigh between 0.2g and 1.0g. However, it is to be understood that the weight value of the moveable weight members 40, 50 are given as examples only; other weight values may be used depending on the desired weight distribution, the type of club, gender and size of the golfer, etc. It is further to be understood that the weight values may also vary depending on the type of sporting article and its intended use.

[0037] Referring to Figures 3A and 3B, there is shown a cross sectional view of the interaction between the first moveable weight member 40 and the transversal guide section 22. It is to be understood that the first moveable weight member 40 may similarly interact with the longitudinal guide section 24 and that the second moveable weight member 50 may similarly interact with either or both of the transversal 22 and longitudinal 24 guide sections.

[0038] The first moveable weight member 40 includes an external element 40a, an intermediate element in the form of a locking element 41, which includes a head portion 43, a threaded body 45 and a blocking portion 47, and an internal element 49. The threaded body 45 operatively engages the internal element 49, which has a complementary thread pattern. The blocking portion 47 ensuring that the internal element 49 remains operatively connected to the locking element 41.

[0039] The first moveable weight member 40 may be engaged to the golf club head 100 by inserting the internal element 49 into the transversal guide section 22, which forms a channel within the golf club head 100, through an opening 26 which is located near the heel portion 15, the locking element 41 protruding from a slot 22a in the transversal guide section 22 such that the external element 40a rests on the outer surface 10 of the golf club head 100. It is to be understood that the opening 26 may be located at the toe portion 14, along the longitudinal guide section 24 or may be absent altogether in an

alternative embodiment were the moveable weight members 40 and 50 are not removable.

[0040] Although not illustrated, it is to be understood that the second moveable weight member 50 may be described in a similar fashion as the first moveable weight member 40. Furthermore, the second moveable weight member 50 may be engaged to the transversal 22 and longitudinal 24 guide sections in a fashion similar to the first moveable weight member 40.

Locking

[0041] Rotating the head portion 43 of the locking element 41 in a first direction results in the external element 40a and the internal element 49 moving towards each other. The size of the external 40a and internal 49 elements being greater than the slot 22a of the transversal guide section 22, the external 40a and internal 49 elements respectively frictionally abut the outer surface 10 of the golf club head 100 and part of the internal surface 22b of the transversal guide section 22, thereby locking the first moveable weight member 40 at a given position along the transversal guide section 22, as best seen in Figure 3B.

[0042] Advantageously, the geometry of the internal element 49 may be such as to be complementary to the geometry of the transversal guide section 22 so as to maximize the contact between the internal element 49 and part of the internal surface 22b of the transversal guide section 22.

Unlocking

[0043] Rotating the head portion 43 of the locking element 41 in a second opposite direction results in the external element 40a and the internal element 49 moving away from each other, thus unlocking the first moveable weight member 40 and allowing for a space 19 to be created between the external element 40a and the outer surface 10 of the golf club head 100 so

that the first moveable weight member 40 may be moved along the transversal guide section 22, as best seen in Figure 3A. As previously mentioned, the blocking portion 47 ensures that in an unlocked position the internal element 49 remains operatively connected to the locking element 41.

[0044] Figures 4A, 4B, 5A and 5B show alternative embodiments of the internal element 49', 49'' and corresponding transversal guide section 22', 22'' having complimentary geometries. It is to be understood that other geometries may be used as well.

[0045] It is also to be understood that other locking means may be used in order to secure the moveable weight member 40 in a desired position and to release it in order to modify the weight configuration of the sporting article.

[0046] Although the above description makes reference to the transversal guide section 22, it is further to be understood that it may similarly apply to the longitudinal guide section 24 (or even a diagonal guide section in an alternative embodiment).

[0047] Referring to Figures 2 and 6, the transversal 22 and longitudinal 24 guide sections may be of various length. For example, in the illustrated embodiment the transversal guide section 22 may be of a length such that the first moveable weight member 40 may have a range of possible positions from line 62, at the heel portion 15, to line 64, at the toe portion 14, of about 110° along the rear portion 18. The extreme positions of the first moveable weight member 40 are identified by numerals 40' and 40''. It is to be understood that the range of possible positions may be other than 110°, for example 120° if we use positions from line 62' to line 64.

[0048] The moveable weight members 40 and 50 may also include transversal and/or longitudinal position indicators. In the illustrated embodiment the first moveable weight member 40 includes a transversal 42 and longitudinal 44 position indicator while the second moveable weight

member 50 includes a longitudinal position indicator 34. Complementary transversal 32 and longitudinal 34 position markers may also be provided on the golf club head 100 so that a golfer may remember the position of the moveable weight members 40 and 50 in a desired weight configuration. Furthermore, the user may wish to use various weight configurations depending on the desired effect or shot.

[0049] It is to be understood that in the case of alternative embodiments having diagonal guide sections, the moveable weight members 40 and 50 may also include diagonal position indicators (not shown).

[0050] Referring now to Figures 7 and 8, there are shown two examples of weight configurations. In particular, Figure 8 shows a configuration with only the first moveable weight member 40 present, which is positioned in the longitudinal guide section 24, thus the presence of the longitudinal indicator 44. The Figure 8 configuration illustrates that the first moveable weight member 40, may be used in the longitudinal guide section 24 as well as the transversal guide section 22 and that moveable weight members are not restricted to a specific guide section.

[0051] Referring to Figures 9 to 12, there are shown further illustrative embodiments of golf club heads 200, 300, 400 and 500 having various combinations of transversal, longitudinal and diagonal guide sections. More specifically, Figure 9 shows a golf club head 200 having a transversal guide section 22 and two longitudinal guide sections 23, 25, a first longitudinal guide section 23 biased towards the heel portion 15 and a second longitudinal guide section 25 biased towards the toe portion 14.

[0052] Figure 10 shows a golf club head 300 having a longitudinal guide section 24 and two transversal guide sections 21, 22, a first transversal guide section 21 biased towards the sole portion 13 and a second transversal guide section 22 biased towards the crown portion 12.

[0053] As for Figure 11, it shows a golf club head 400 having two transversal guide sections 21, 22 a first transversal guide section 21 biased towards the sole portion 13 and a second transversal guide section 22 biased towards the crown portion 12, and two longitudinal guide sections 23, 25, a first longitudinal guide section 23 biased towards the heel portion 15 and a second longitudinal guide section 25 biased towards the toe portion 14.

[0054] Finally, Figure 12 shows a golf club head 500 having a transversal guide section 22, a longitudinal guide section 25, biased towards the heel portion 15, and a diagonal guide section 47, biased towards the toe portion 14.

[0055] It is to be understood that the illustrative embodiments of Figures 9 to 12 are not meant to be exhaustive and that many other embodiments having various combinations of transversal and/or longitudinal and/or diagonal guide sections may be used, as well as embodiments with discontinuous guide sections.

[0056] Although a golf club head was used as an example of a sporting article in the above description, it is to be understood that the adjustable weight configuration may also be used with other sporting articles such as, for example, racquets (tennis, badminton, squash, racquetball, ping pong, etc.), hockey sticks, skis, curling brooms, polo sticks, baseball bats, croquet sticks, cricket sticks, lacrosse sticks or any other sporting goods where repartition of the weight balance may have an impact on the user's performance and/or use of the sporting article.

[0057] For example, Figures 13 and 14 show a racket 600 having a guide section 692, with opening 696, running along a portion of the frame 662 of the racket head 664. A moveable weight member 690, with locking element 691, is engaged to the guide section 692 and may be moved along the guide section 692 so as to modify the balance of the racket 600 by locking it into place using the locking element 691. The moveable weight member 690 may

be engaged or removed from the guide section 692 using the guide section opening 696.

[0058] In another example, Figure 15 shows a hockey stick 700 having a guide section 792, with opening 796, running along a portion of the shaft 762 of the hockey stick 700. A moveable weight member 790, with locking element 791, is engaged to the guide section 792 and may be moved along the guide section 792 so as to modify the balance of the hockey stick 700 by locking it into place using the locking element 791. The moveable weight members 790 may be engaged or removed from the guide section 792 using the guide section opening 796. It is to be understood that the guide section 792 may be positioned at different locations on the hockey stick 700 and that multiple guide sections and/or moveable weight members may be used.

[0059] In a further example, Figure 16 shows a ski 800 having a guide section 892, with opening 896, running along a portion of the upper surface 862 of the ski 800. A moveable weight member 890, with locking element 891, is engaged to the guide section 892 and may be moved along the guide section 892 so as to modify the balance of the ski 800 by locking it into place using the locking element 891. The moveable weight members 890 may be engaged or removed from the guide section 892 using the guide section opening 896. It is to be understood that the guide section 892 may be positioned at different locations on the ski 800 and that multiple guide sections and/or moveable weight members may be used.

[0060] In yet another example, Figure 17 shows a ski 900 having a first 992 and second guide section 993, with opening 996, running along a portion of the upper surface 962 of the ski 900, the first 992 and second 993 guide sections crossing each other at an angle. A moveable weight member 990, with locking element 991, is engaged to the guide section 992 and may be moved along the either of the first 992 and second 993 guide section so as to modify the balance of the ski 900 by locking it into place using the locking

element 991. The moveable weight members 990 may be engaged or removed from the guide section 992 using the guide section opening 996. It is to be understood that the first 992 and second 993 guide section may be positioned at different locations on the ski 900, at various angle and that multiple guide sections and/or moveable weight members may be used.

[0061] It is to be understood that in the illustrative embodiments of Figures 13 to 17 the moveable weight members 690, 790, 890 and 990 may be permanently engaged to their respective guide sections 692, 792, 892 and 992, in which case openings 696, 796, 986 and 996 may be omitted. It is also to be understood that although not shown, the locking elements 691, 791, 891 and 991 may be similar to the locking element 41 shown in Figures 3A to 5B.

[0062] It is further to be understood that the illustrative embodiments of Figures 13 to 17 are not meant to be exhaustive and that many other embodiments the adjustable weight configuration may be used with other sporting articles and in various other configurations.

[0063] It is to also be understood that the various features of the various embodiments described above may be combined in a variety of ways within the context of the present invention.

[0064] Although the present invention has been described by way of a non-limitative illustrative embodiments and examples thereof, it will be apparent to persons skilled in the art that modifications may be applied to the illustrative embodiments without departing from the scope of the present invention.

What is claimed is:

1. A sporting article comprising:

at least one body portion providing a guide, said at least one body portion defining a generally longitudinal length, a generally transversal length and a generally diagonal length thereof; and said guide comprising at least two guide sections; and

at least one moveable weight member for being moveably engaged to said guide;

wherein each of said guide sections provides for selectively moving said moveable weight member along at least one of said generally longitudinal, generally transversal and generally diagonal lengths of said at least one body portion.

2. A sporting article according to claim 1, wherein said at least two guide sections comprise discontinuous guide sections.

3. A sporting article according to claim 2, wherein at least one of said guide sections provides for selectively moving said moveable weight member along the generally longitudinal length of said body portion.

4. A sporting article according to claim 2, wherein at least one of said guide sections provides for selectively moving said moveable weight member along the generally transversal length of said body portion.

5. A sporting article according to claim 2, wherein at least one of said guide sections provides for selectively moving said moveable weight member along the generally diagonal length of said body portion.

6. A sporting article according to claim 1, wherein said at least two guide sections comprise contiguous guide sections.

7. A sporting article according to claim 6, wherein at least one of said guide sections provides for selectively moving said moveable weight member along the generally longitudinal length of said body portion.

8. A sporting article according to claim 6, wherein at least one of said guide sections provides for selectively moving said moveable weight member along the generally transversal length of said body portion.

9. A sporting article according to claim 6, wherein at least one of said guide sections provides for selectively moving said moveable weight member along the generally diagonal length of said body portion.

10. A sporting article according to any of claims 1 to 9, wherein each of said guide sections comprise a channel.

11. A sporting article according to claim 10, wherein said moveable weight member comprises:

an external element for being positioned externally relative to said channel;

an internal element for being positioned within said channel; and

an intermediate element for mounting said external and internal elements thereon near opposite ends thereof;

wherein when engaging said moveable weight member to one of said channel, selective actuation of said intermediate element provides for moving said external and internal elements closer to one another along said intermediate element causing said external and internal elements to respectively frictionally abut an external surface said body portion and an internal surface of said channel thereby locking said moveable weight member at a given position along said channel.

12. A sporting article according to claim 11, wherein said channel comprises a slot having a size smaller than the size of said internal element, thereby

preventing said moveable weight member from being removed from said guide sections.

13. A sporting article according to claim 12, wherein at least one of said guide sections has a slot comprising an opening having a size greater than the size of said internal element, thereby providing for the removal of said moveable weight member from said at least one of said guide sections.

14. A sporting article according to any of claims 1 to 13, further comprising:

positioning indicators provided on said at least one body portion along said guide;

wherein said moveable weight member is configured to be lockingly positioned at a desired position indicated by a given said positioning indicators along said guide.

15. A sporting article according to any of claims 1 to 14, wherein said sporting article is selected from a group consisting of a tennis racquet, a badminton racket, a squash racket, a racquetball racket, a ping pong racket, a hockey stick, a ski, a curling broom, a polo stick, a baseball bat, a croquet stick, a cricket stick and a lacrosse sticks.

16. A sporting article comprising:

a guide channel formed within at least one body portion of said sporting article; and

at least one moveable weight member for being moveably engaged within said guide channel, said moveable weight member comprising:

an external element for being positioned externally relative to said guide channel;

an internal element for being positioned within said guide channel; and

an intermediate element for mounting said external and internal elements thereon near opposite ends thereof;

wherein when mounting said moveable weight member to said guide channel, selective actuation of said intermediate element provides for moving said external and internal elements closer to one another along said intermediate element causing said external and internal elements to respectively frictionally abut an external surface said body portion and an internal surface of said guide channel thereby locking said moveable weight member at a given position along said guide channel.

17. A sporting article according to claim 16, wherein said at least one body portion defines a generally longitudinal length, a generally transversal length and a generally diagonal length thereof.

18. A sporting article according to claim 17, wherein said guide channel provides for selectively moving said moveable weight member along at least one of said generally longitudinal, generally transversal and generally diagonal lengths of said at least one body portion.

19. A sporting article according to claim 17, wherein said guide channel comprises at least two guide channel sections.

20. A sporting article according to claim 18, wherein said at least two guide channel sections comprise discontinuous guide channel sections.

21. A sporting article according to claim 20, wherein at least one of said guide channel sections provides for selectively moving said moveable weight member along the generally longitudinal length of said body portion.

22. A sporting article according to claim 20, wherein at least one of said guide channel sections provides for selectively moving said moveable weight member along the generally transversal length of said body portion.

23. A sporting article according to claim 20, wherein at least one of said guide channel sections provides for selectively moving said moveable weight member along the generally diagonal length of said body portion.

24. A sporting article according to claim 18, wherein said at least two guide channel sections comprise contiguous guide channel sections.

25. A sporting article according to claim 24, wherein at least one of said guide channel sections provides for selectively moving said moveable weight member along the generally longitudinal length of said body portion.

26. A sporting article according to claim 24, wherein at least one of said guide channel sections provides for selectively moving said moveable weight member along the generally transversal length of said body portion.

27. A sporting article according to claim 24, wherein at least one of said guide channel sections provides for selectively moving said moveable weight member along the generally diagonal length of said body portion.

28. A sporting article according any of claims 19 to 27, wherein said guide channel sections comprise a slot having a size smaller than the size of said internal element, thereby preventing said moveable weight member from being removed from said guide channel sections.

29. A sporting article according to claim 28, wherein at least one of said guide channel sections has a slot comprising an opening having a size greater than the size of said internal element, thereby providing for the removal of said moveable weight member from said at least one of said guide channel sections.

30. A sporting article according to any of claims 16 to 28, further comprising:
positioning indicators provided on said at least one body portion along said
guide channel;

wherein said moveable weight member is configured to be lockingly positioned at a desired position indicated by a given said positioning indicators along said guide channel.

31. A sporting article according to any of claims 16 to 30, wherein said sporting article is selected from a group consisting of a tennis racquet, a badminton racket, a squash racket, a racquetball racket, a ping pong racket, a hockey stick, a ski, a curling broom, a polo stick, a baseball bat, a croquet stick, a cricket stick and a lacrosse sticks.

32. A sporting article comprising:

a guide provided on at least one body portion of said sporting article;

positioning indicators being provided on said at least one body portion along said guide; and

at least one moveable weight member for being moveably mounted to said guide;

wherein said moveable weight member is configured to be lockingly positioned at a desired position indicated by a given said positioning indicators along said guide.

33. A sporting article according to claim 32, wherein said at least one body portion defines a generally longitudinal length, a generally transversal length and a generally diagonal length thereof.

34. A sporting article according to claim 33, wherein said guide provides for selectively moving said moveable weight member along at least one of said generally longitudinal, generally transversal and generally diagonal lengths of said at least one body portion.

35. A sporting article according to claim 34, wherein said guide comprises at least two guide sections.

36. A sporting article according to claim 35, wherein said at least two guide sections comprise discontinuous guide sections.

37. A sporting article according to claim 36, wherein at least one of said guide sections provides for selectively moving said moveable weight member along the generally longitudinal length of said body portion.

38. A sporting article according to claim 36, wherein at least one of said guide sections provides for selectively moving said moveable weight member along the generally transversal length of said body portion.

39. A sporting article according to claim 36, wherein at least one of said guide sections provides for selectively moving said moveable weight member along the generally diagonal length of said body portion.

40. A sporting article according to claim 35, wherein said at least two guide sections comprise contiguous guide sections.

41. A sporting article according to claim 40, wherein at least one of said guide sections provides for selectively moving said moveable weight member along the generally longitudinal length of said body portion.

42. A sporting article according to claim 40, wherein at least one of said guide sections provides for selectively moving said moveable weight member along the generally transversal length of said body portion.

43. A sporting article according to claim 40, wherein at least one of said guide sections provides for selectively moving said moveable weight member along the generally diagonal length of said body portion.

44. A sporting article according to any of claims 32 to 43, wherein each of said guide sections comprise a channel.

45. A sporting article according to claim 44, wherein said moveable weight member comprises:

an external element for being positioned externally relative to said channel;

an internal element for being positioned within said channel; and

an intermediate element for mounting said external and internal elements thereon near opposite ends thereof;

wherein when engaging said moveable weight member to one of said channel, selective actuation of said intermediate element provides for moving said external and internal elements closer to one another along said intermediate element causing said external and internal elements to respectively frictionally abut an external surface said body portion and an internal surface of said channel thereby locking said moveable weight member at a given position along said channel.

46. A sporting article according to claims 45, wherein said channel comprises a slot having a size smaller than the size of said internal element, thereby preventing said moveable weight member from being removed from said guide sections.

47. A sporting article according to claim 46, wherein at least one of said guide sections has a slot comprising an opening having a size greater than the size of said internal element, thereby providing for the removal of said moveable weight member from said at least one of said guide sections.

48. A sporting article according to any of claims 33 to 47, wherein said sporting article is selected from a group consisting of a tennis racquet, a badminton racket, a squash racket, a racquetball racket, a ping pong racket, a hockey stick, a ski, a curling broom, a polo stick, a baseball bat, a croquet stick, a cricket stick and a lacrosse sticks.

49. A weight member for a sporting article having a guide channel formed within at least one body portion thereof, said weight member being moveably engaged within said guide channel and comprising:

an external element for being positioned externally relative to said guide channel;

an internal element for being positioned within said guide channel; and

an intermediate element for mounting said external and internal elements thereon near opposite ends thereof;

wherein when engaging said weight member to said guide channel, selective actuation of said intermediate element provides for moving said external and internal elements closer to one another along said intermediate element causing said external and internal elements to respectively frictionally abut an external surface said body portion and an internal surface of said guide channel thereby locking said weight member at a given position along said guide channel.

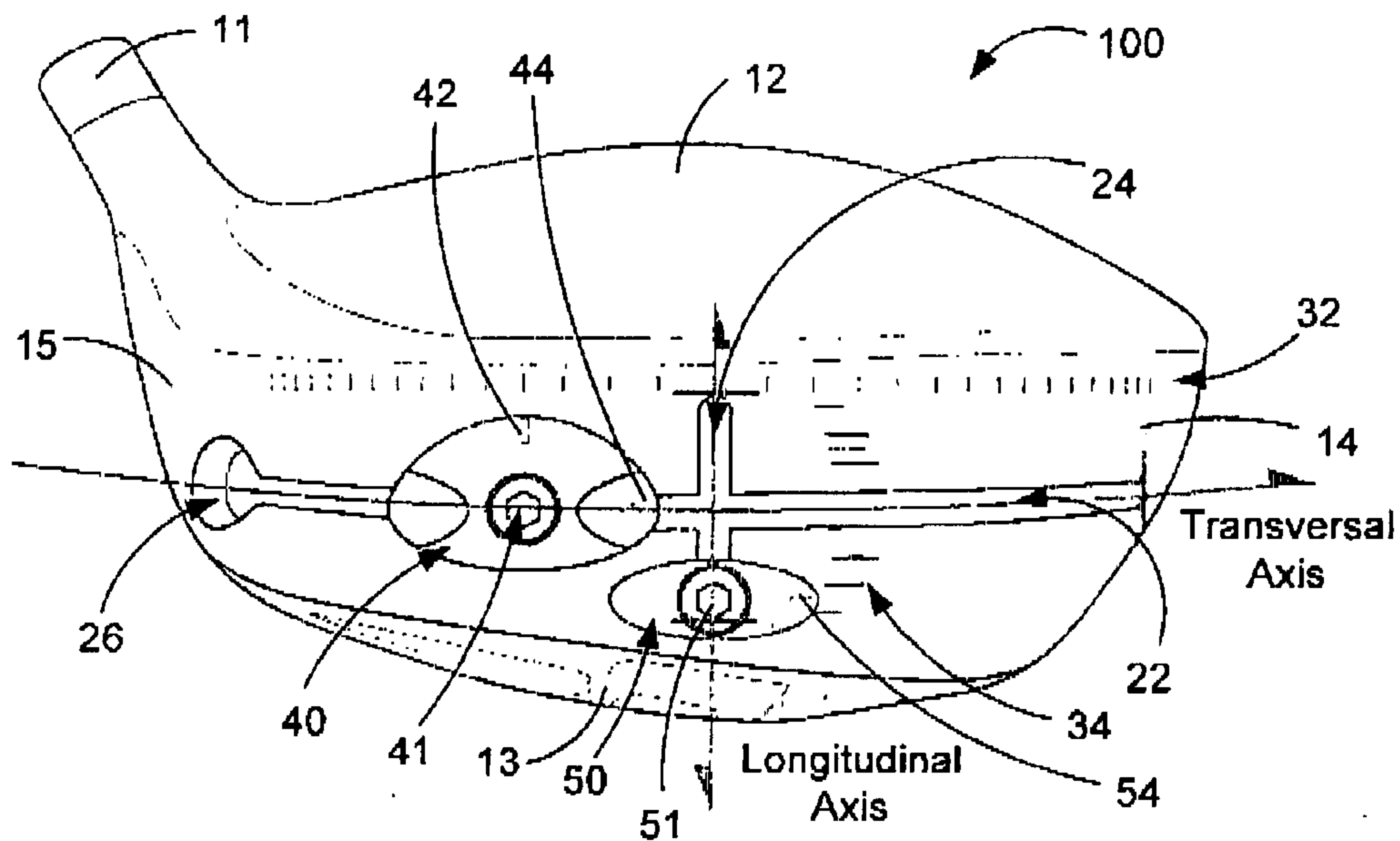

Figure 1

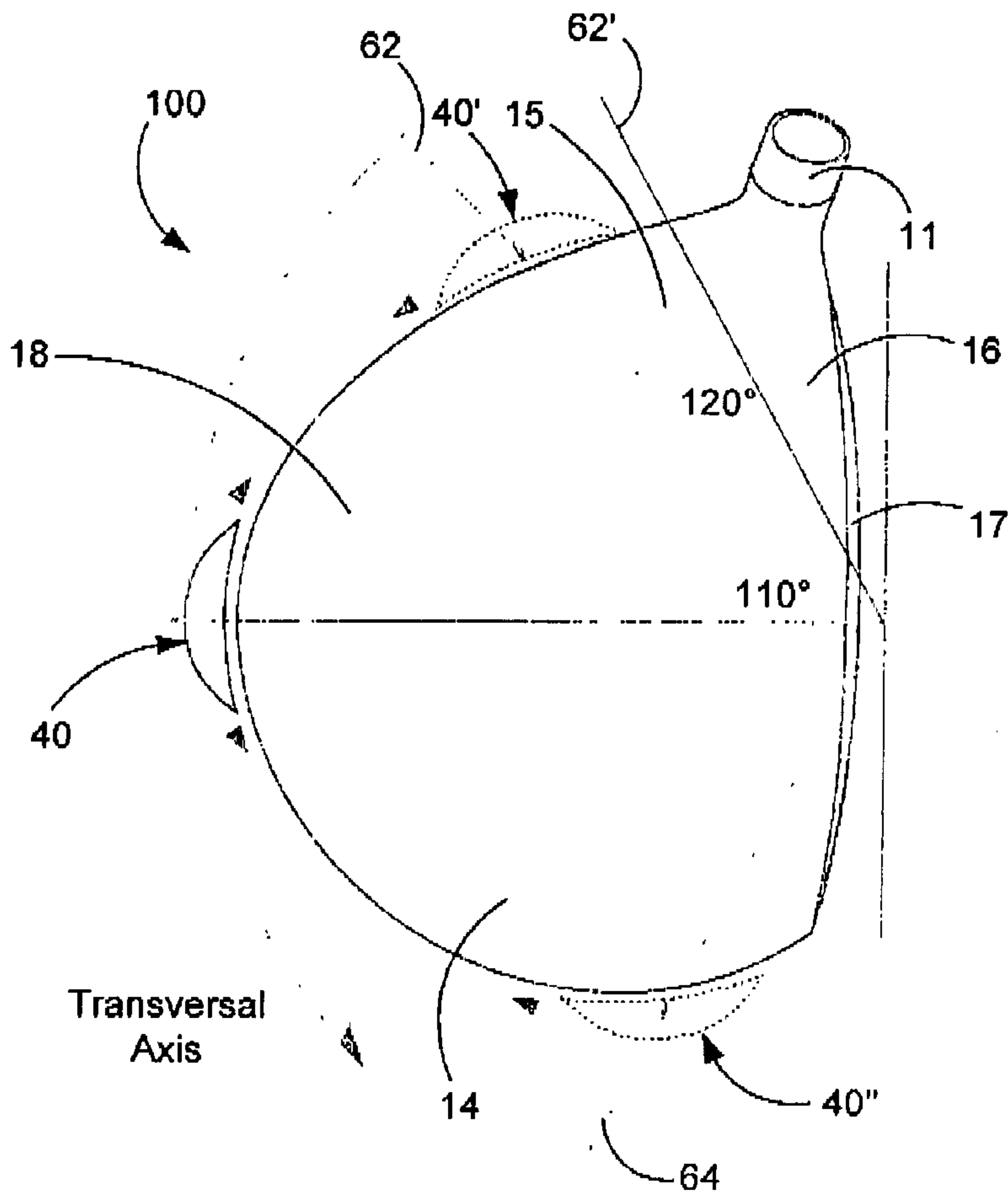

Figure 2

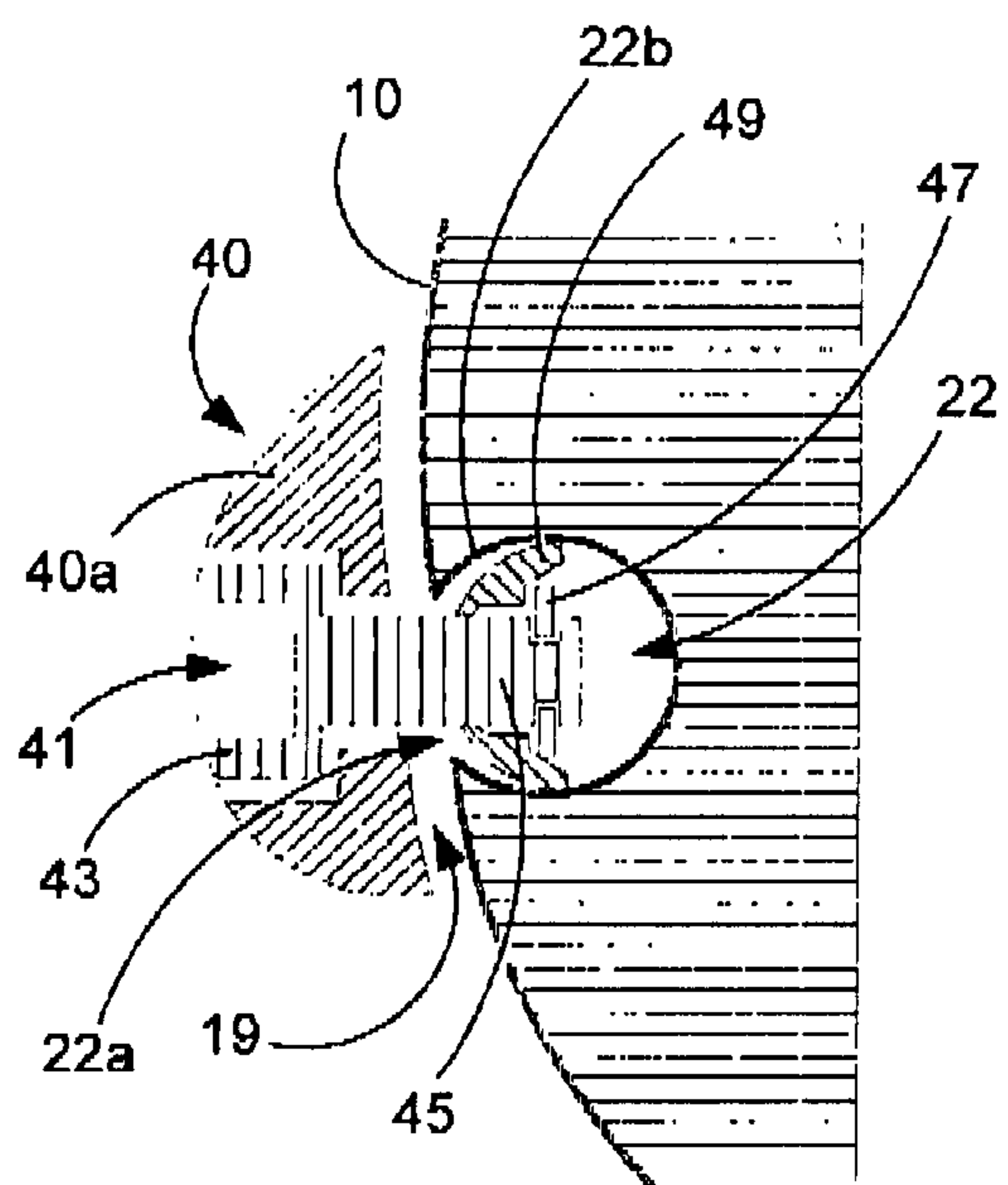

Figure 3A

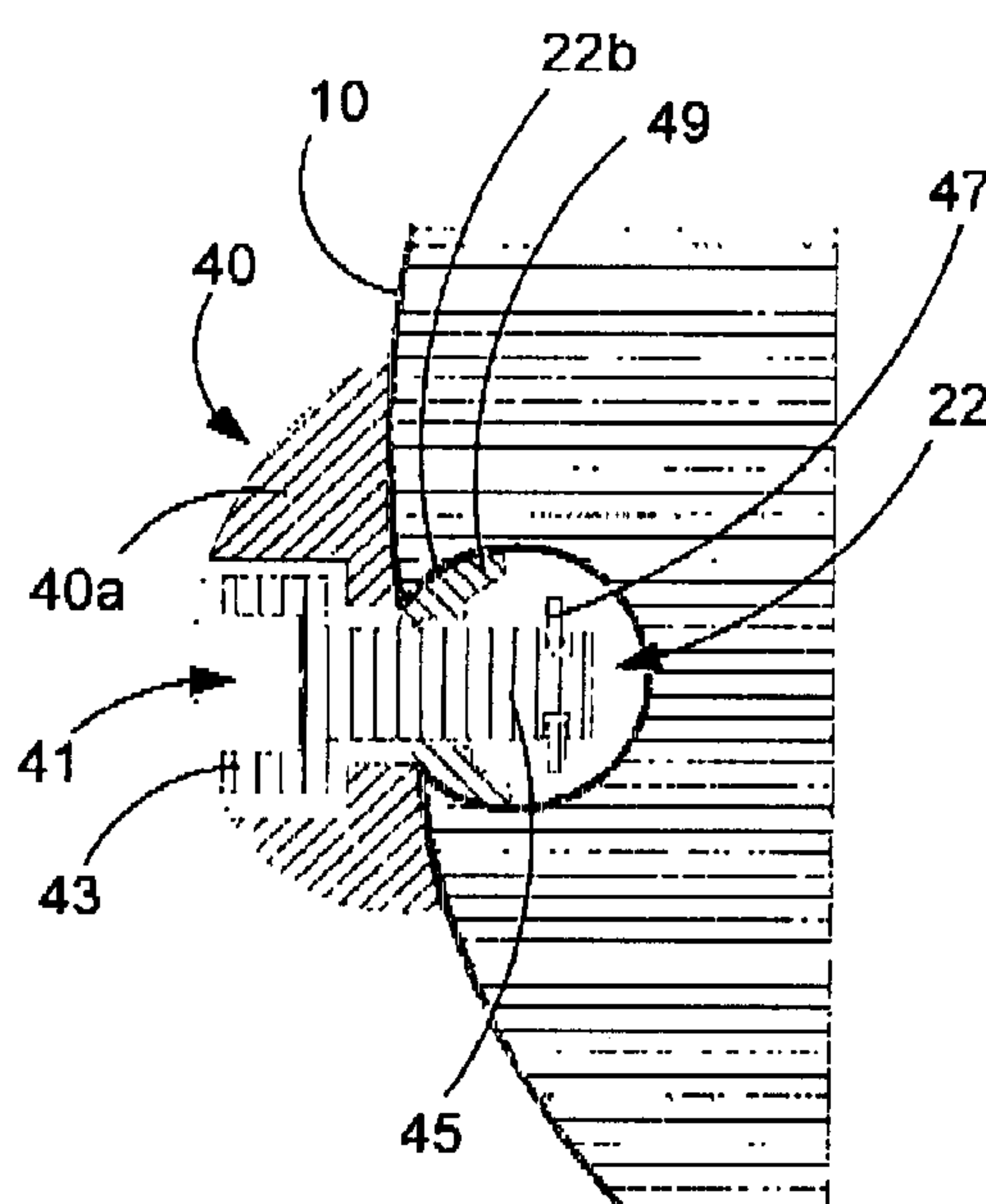

Figure 3B

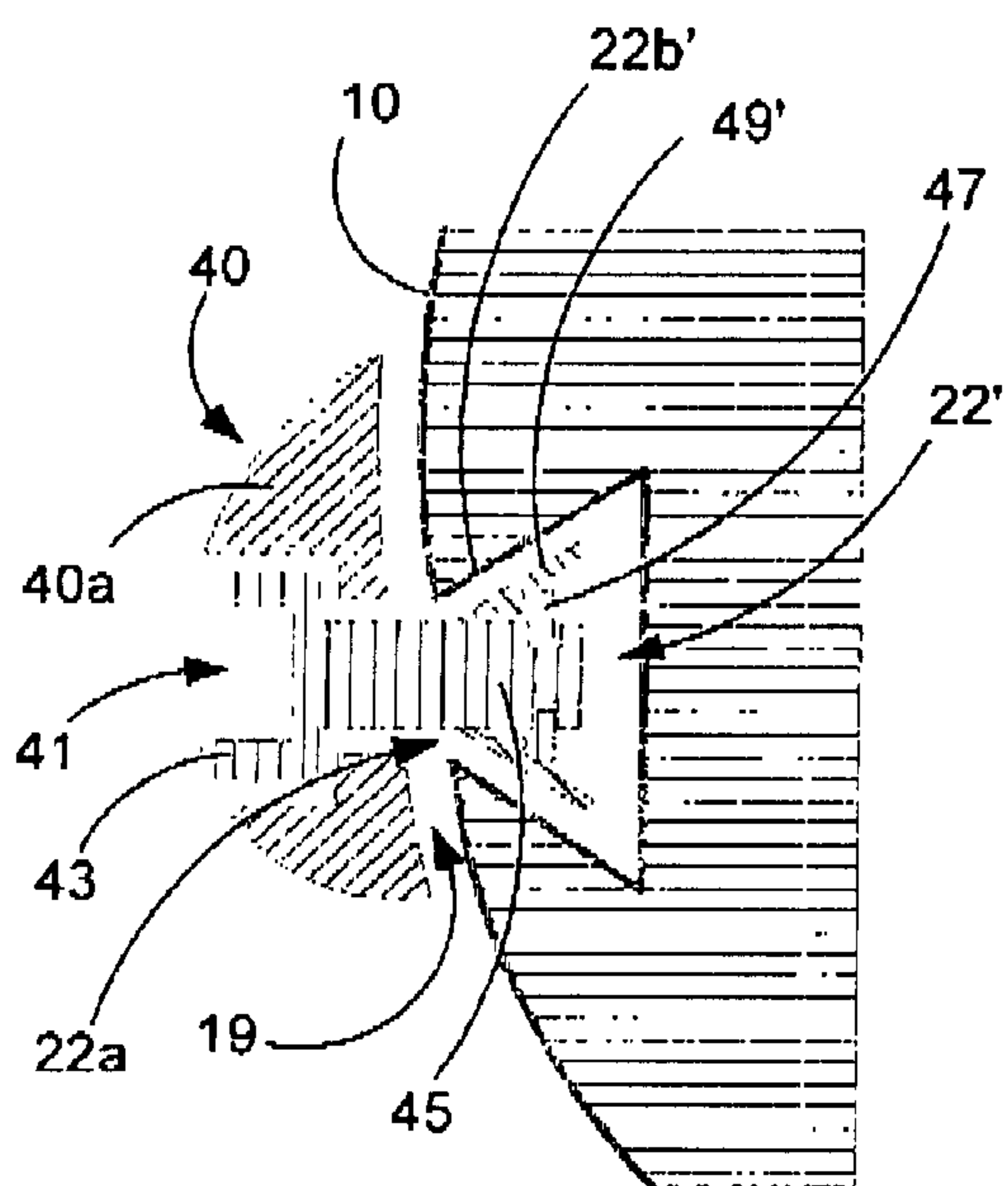

Figure 4A

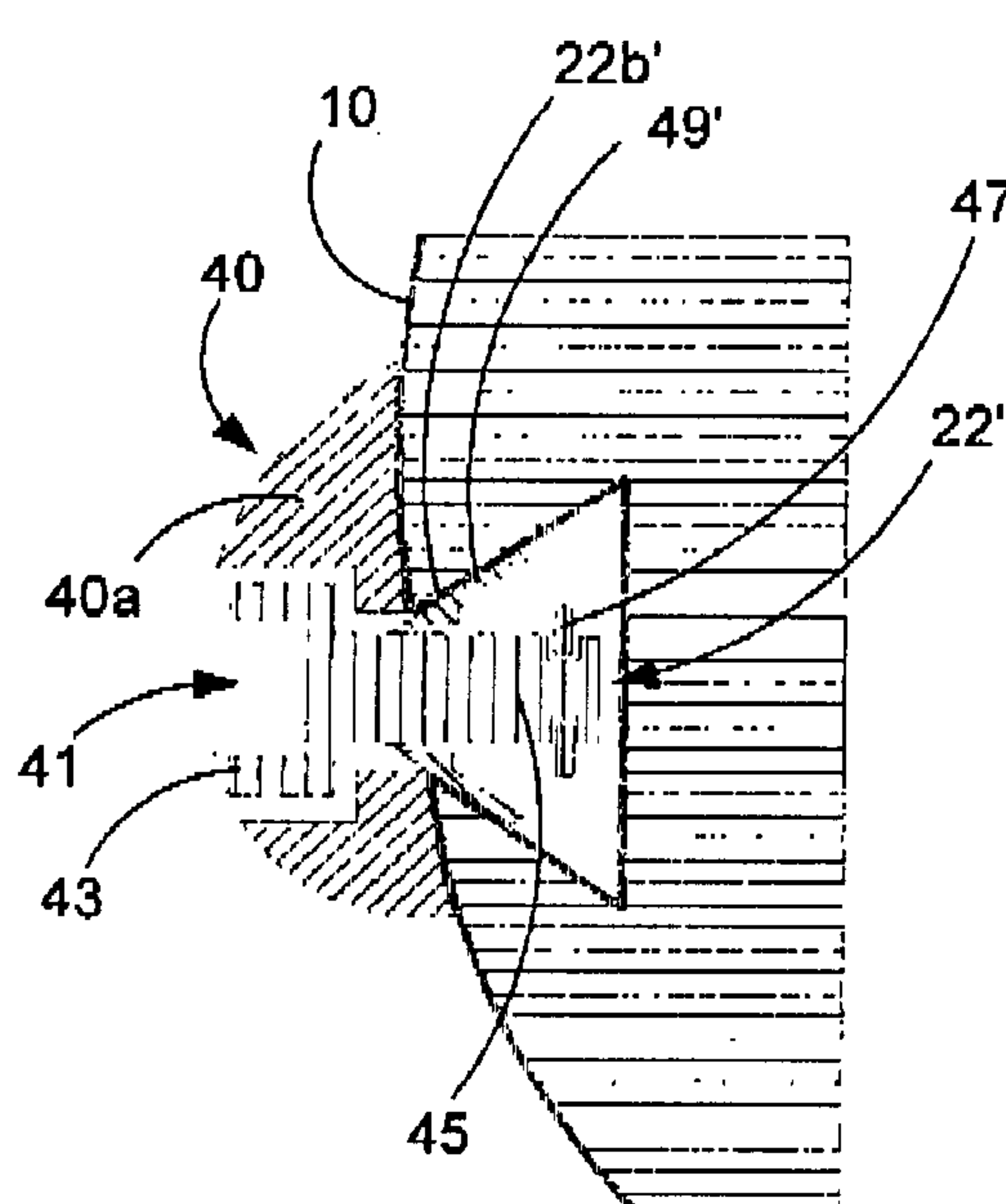

Figure 4B

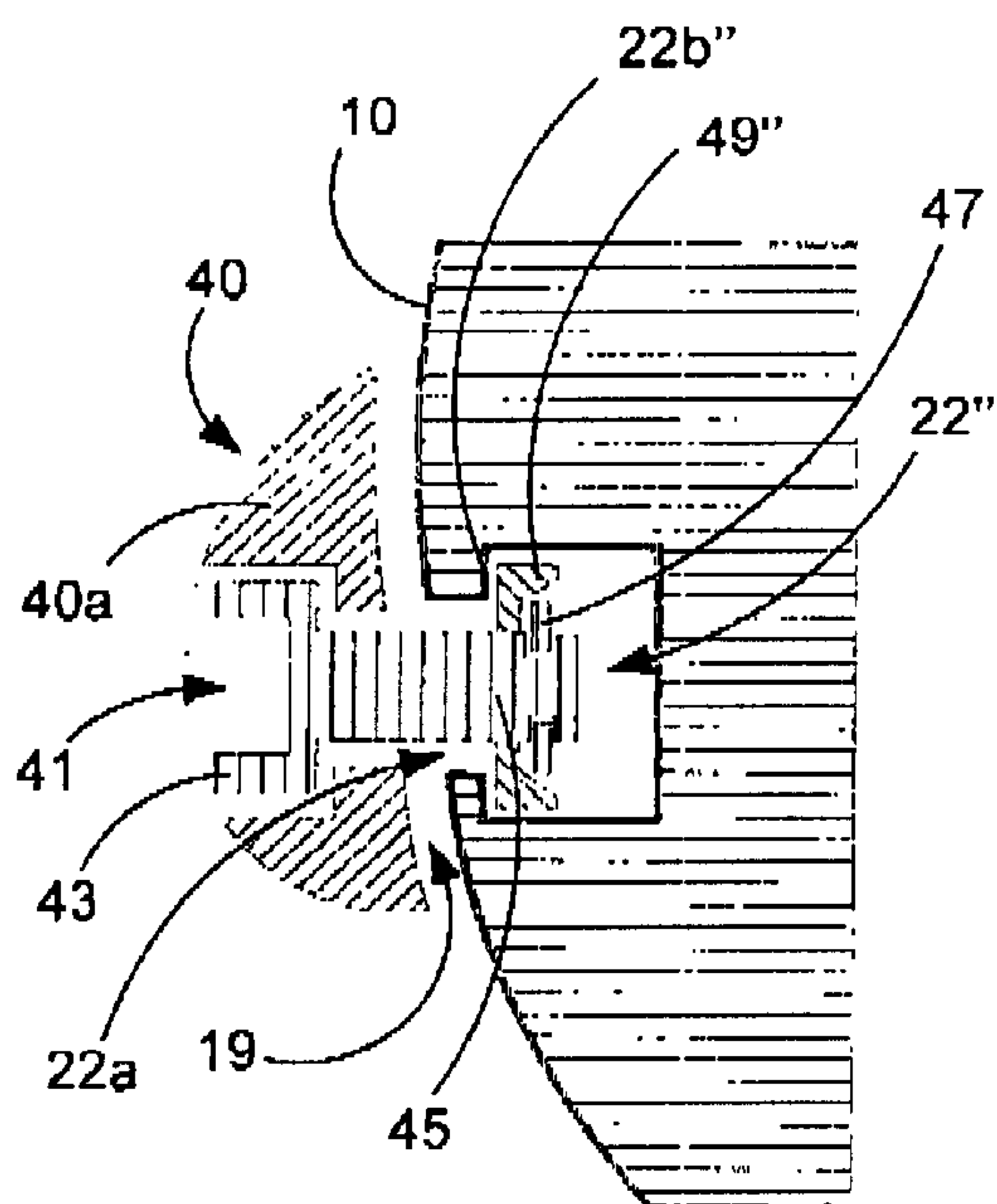

Figure 5A

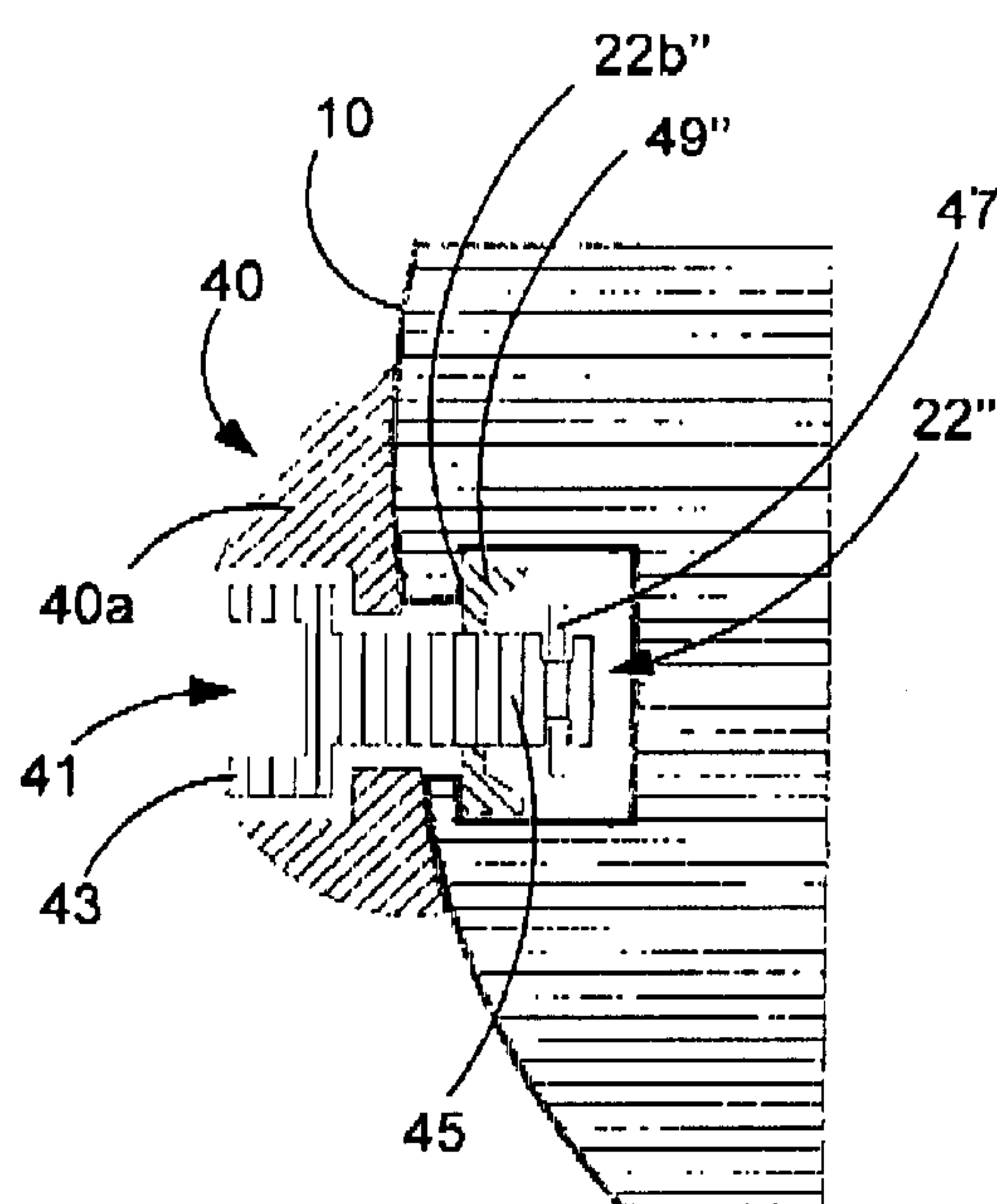

Figure 5B

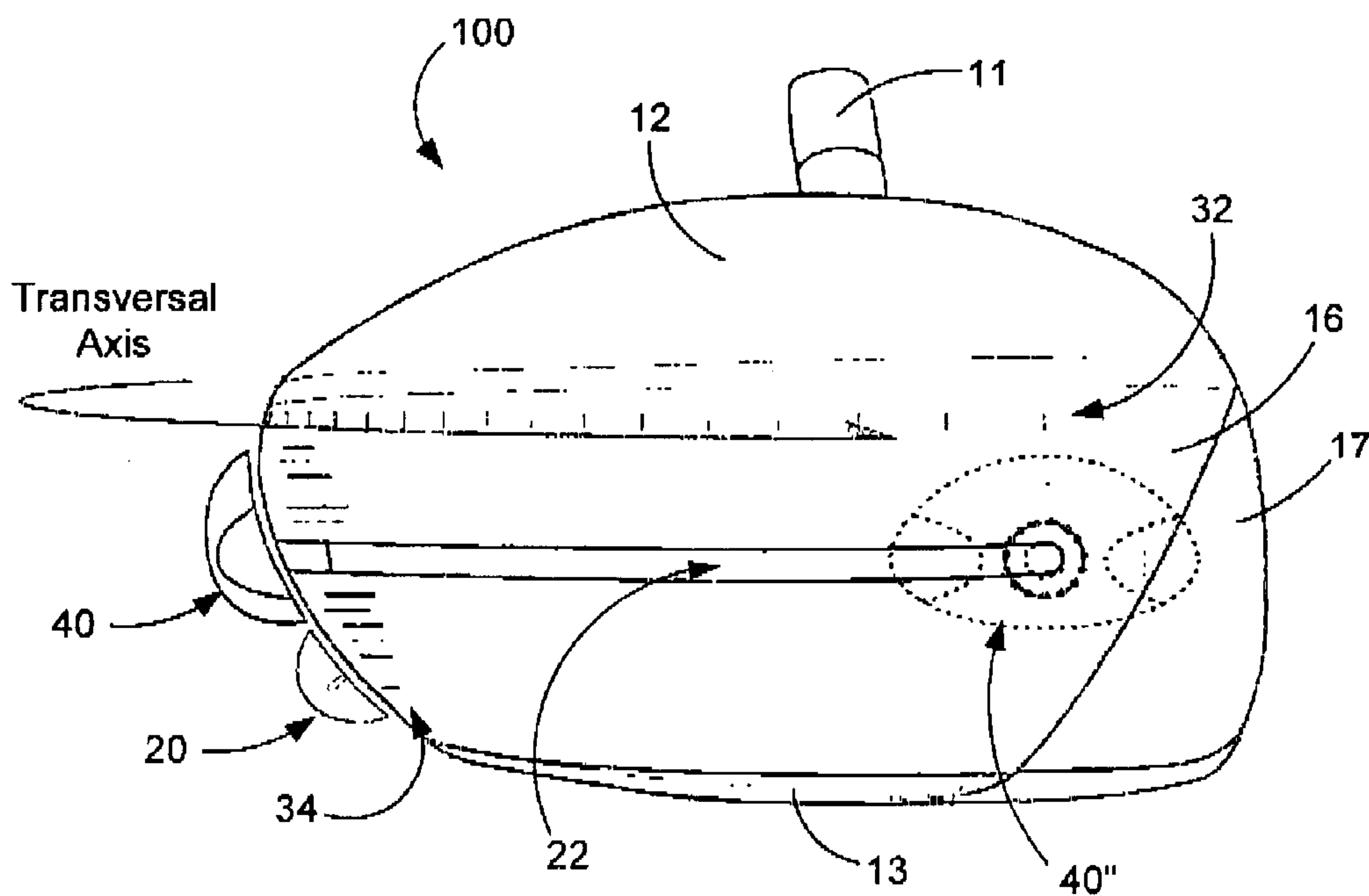

Figure 6

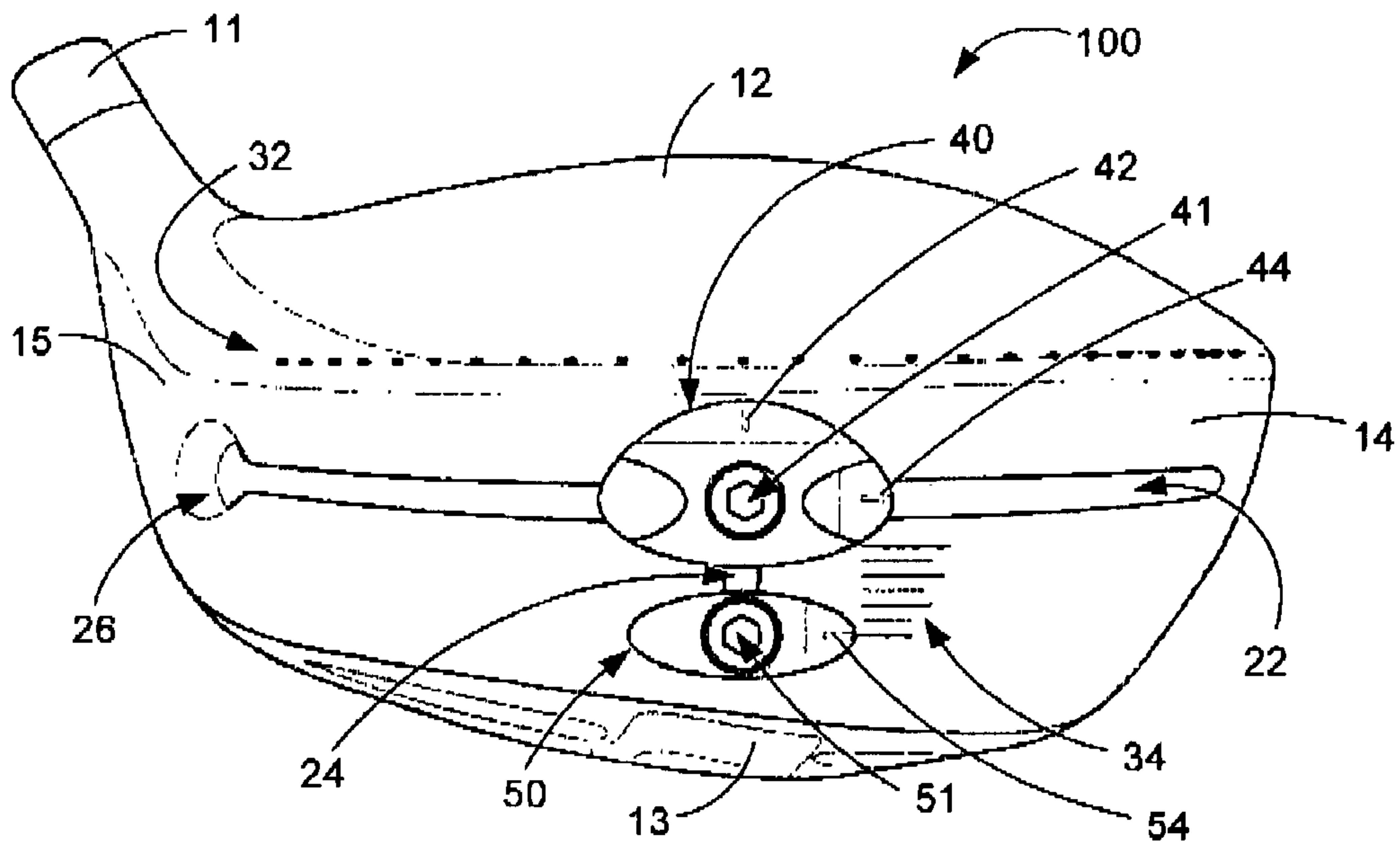

Figure 7

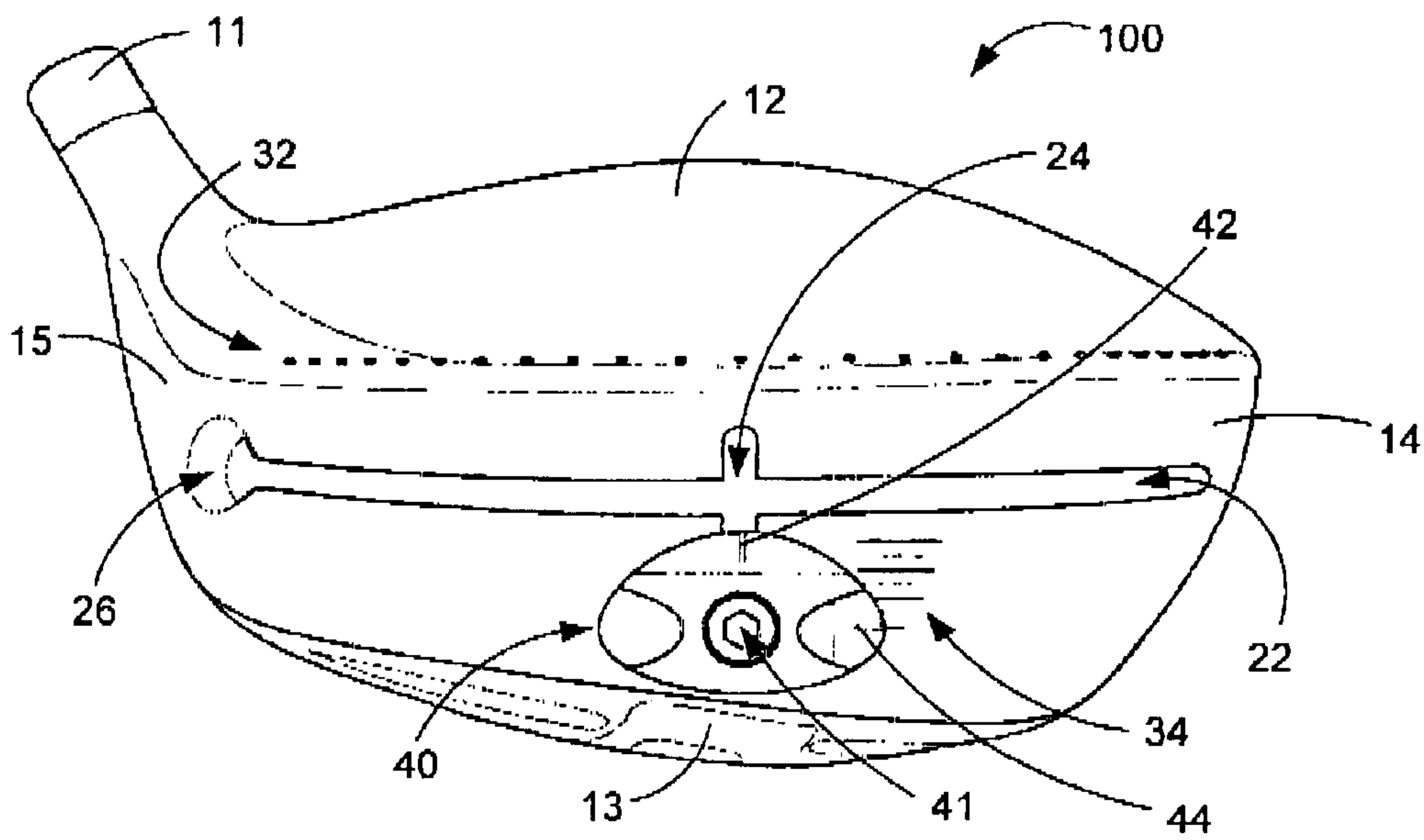

Figure 8

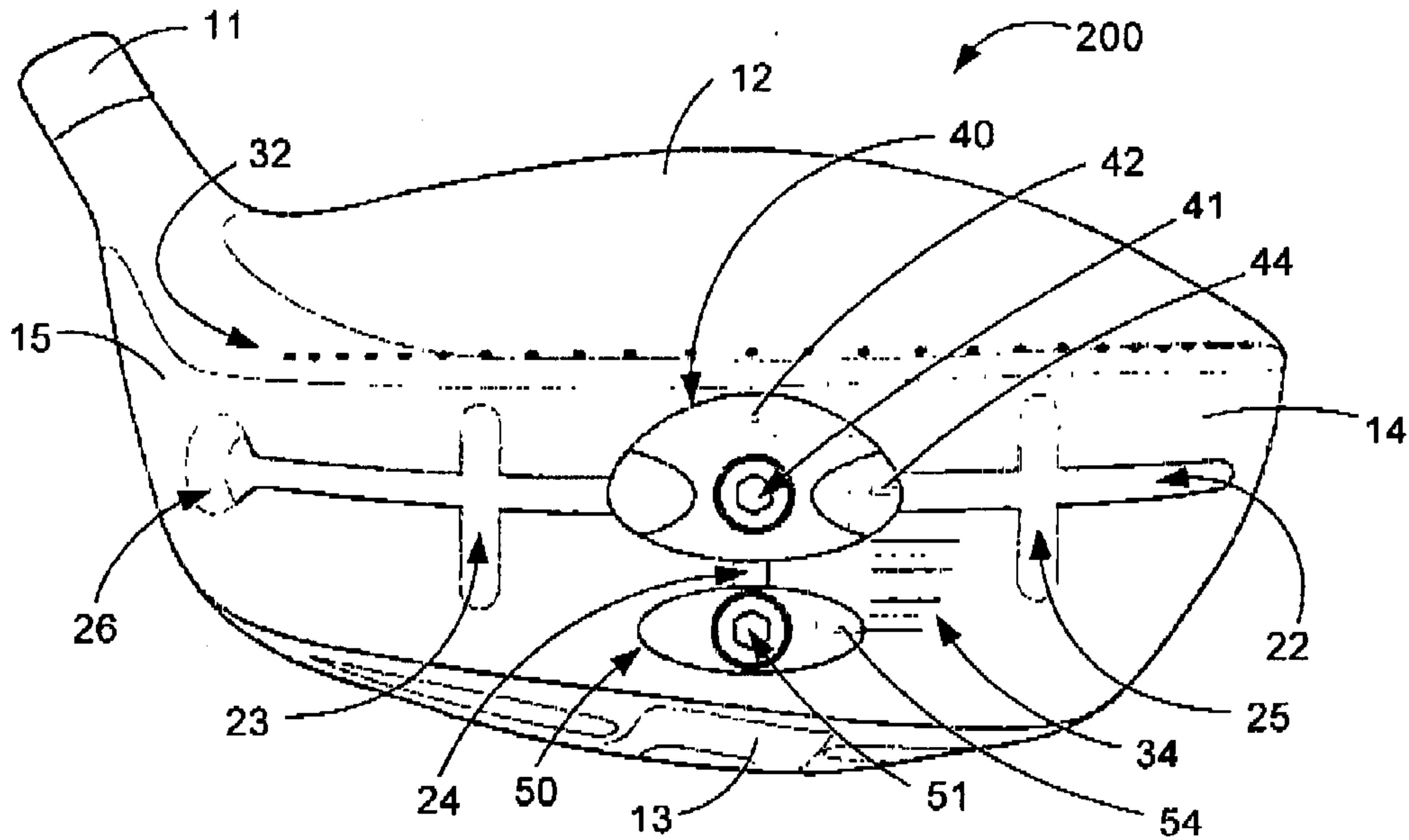

Figure 9

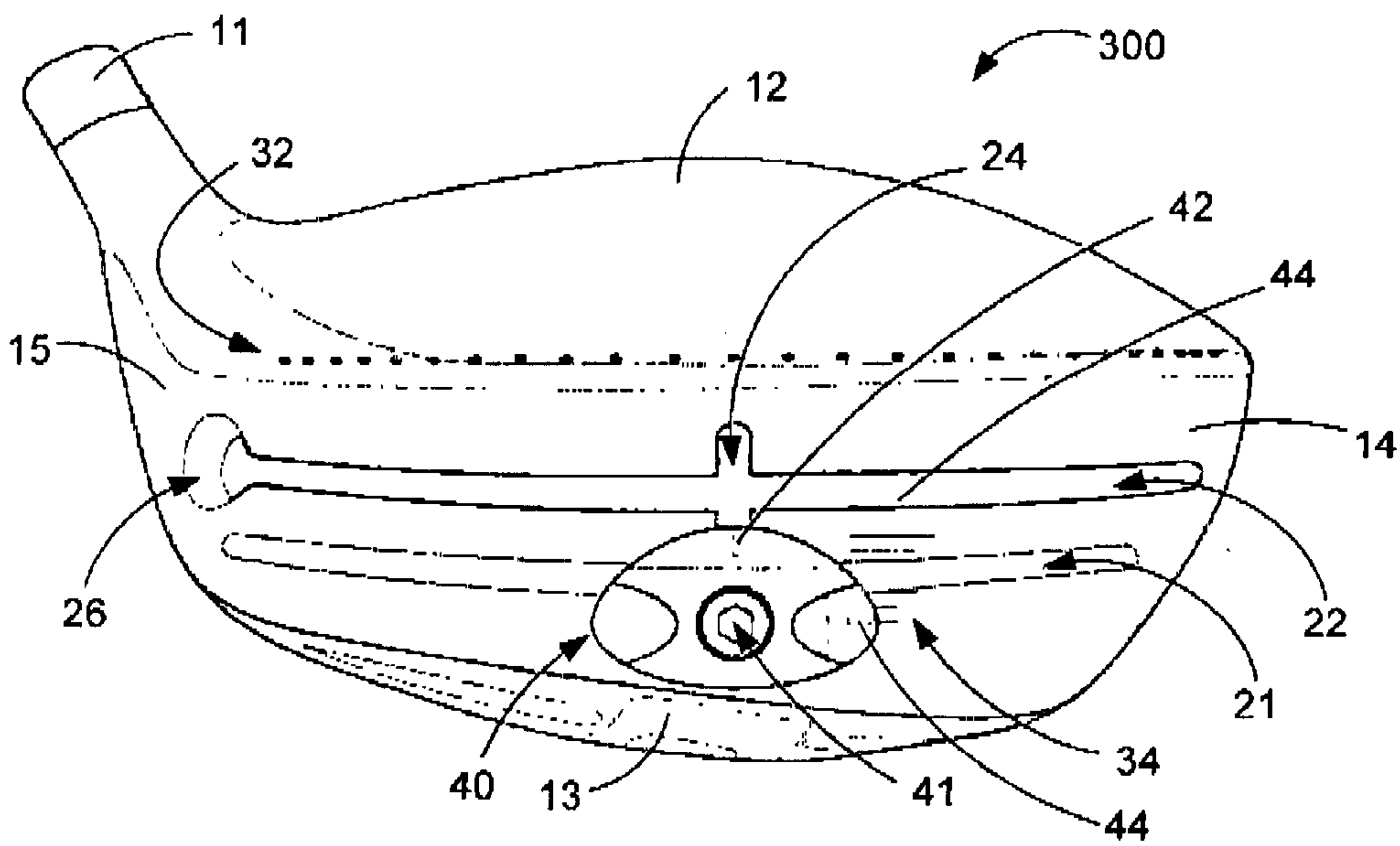

Figure 10

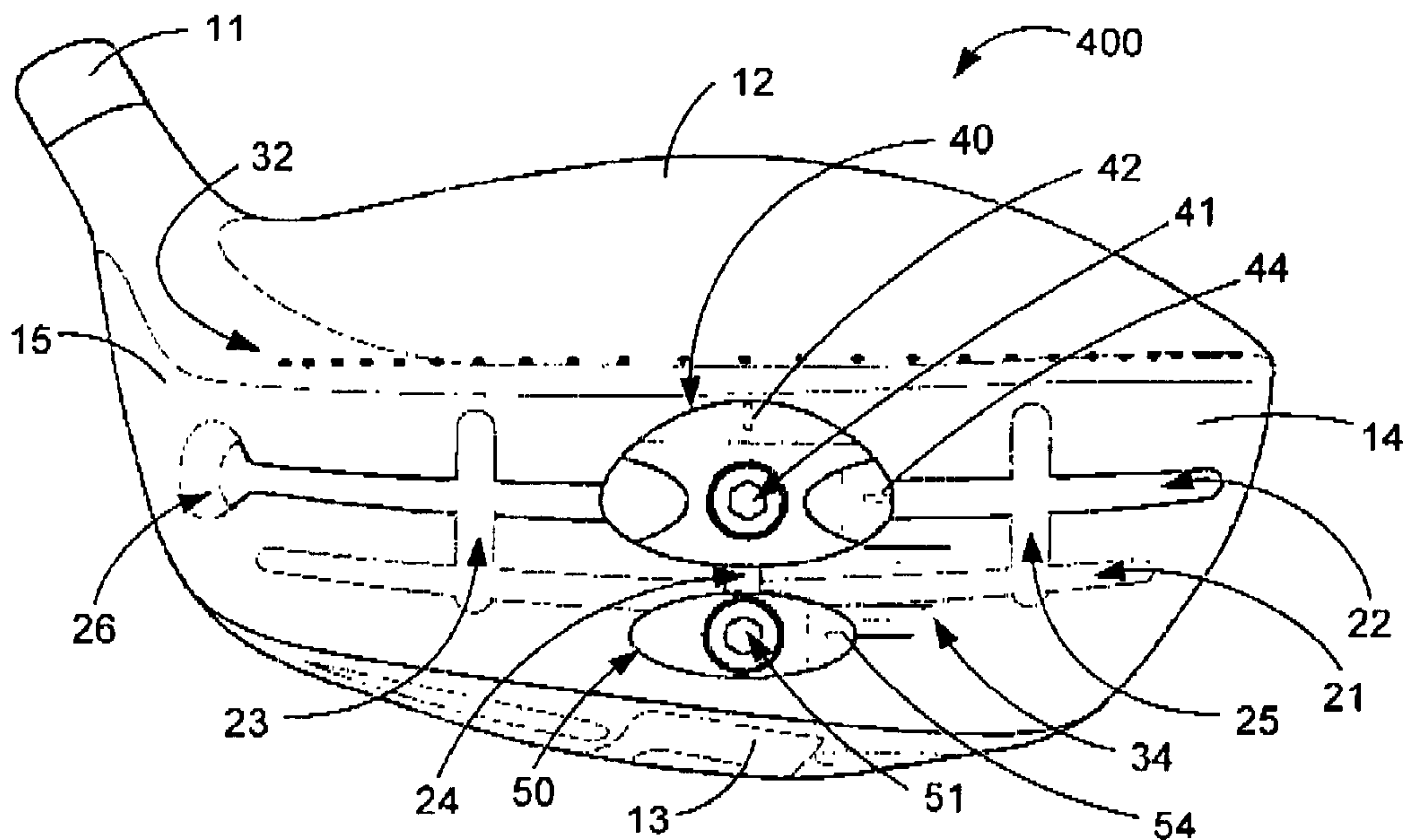

Figure 11

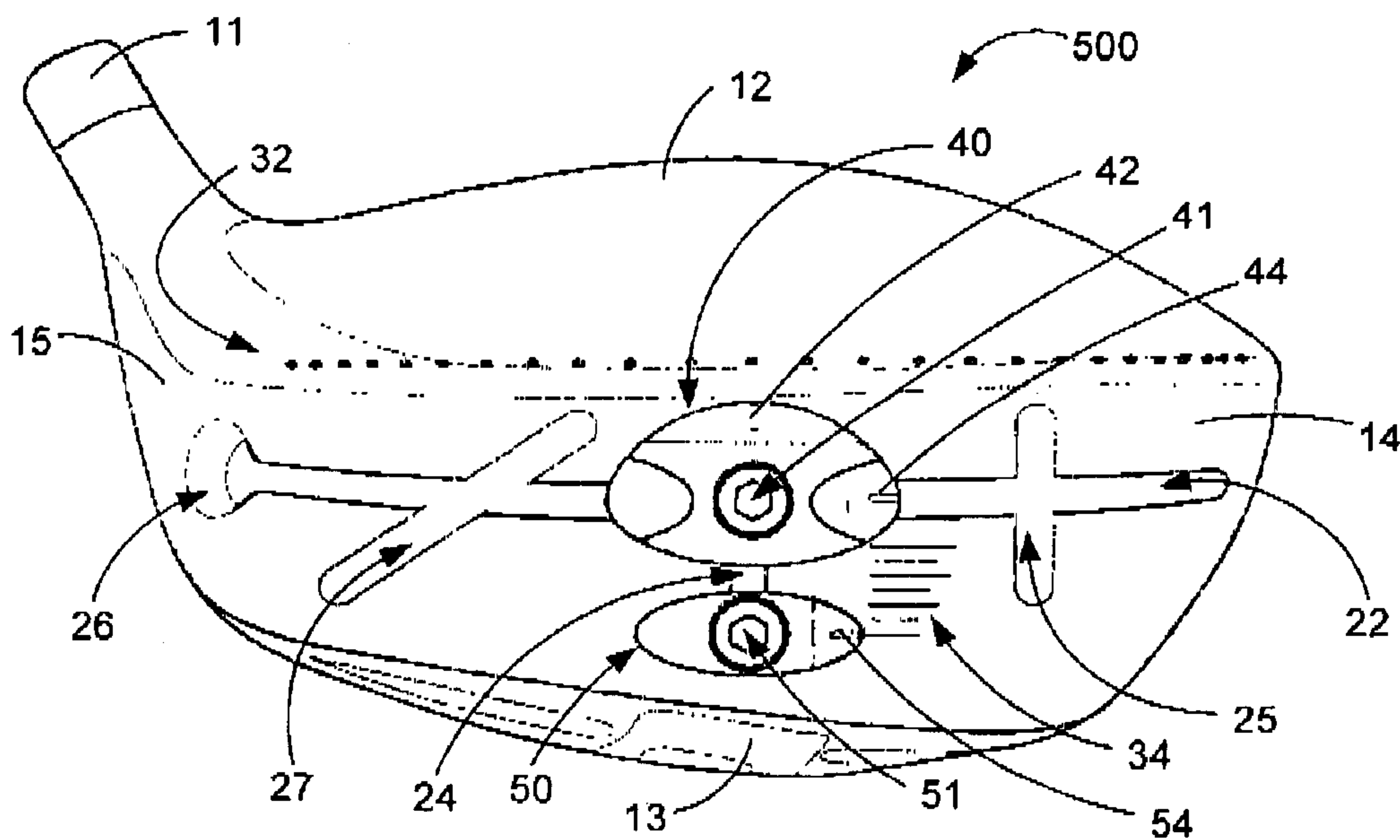

Figure 12

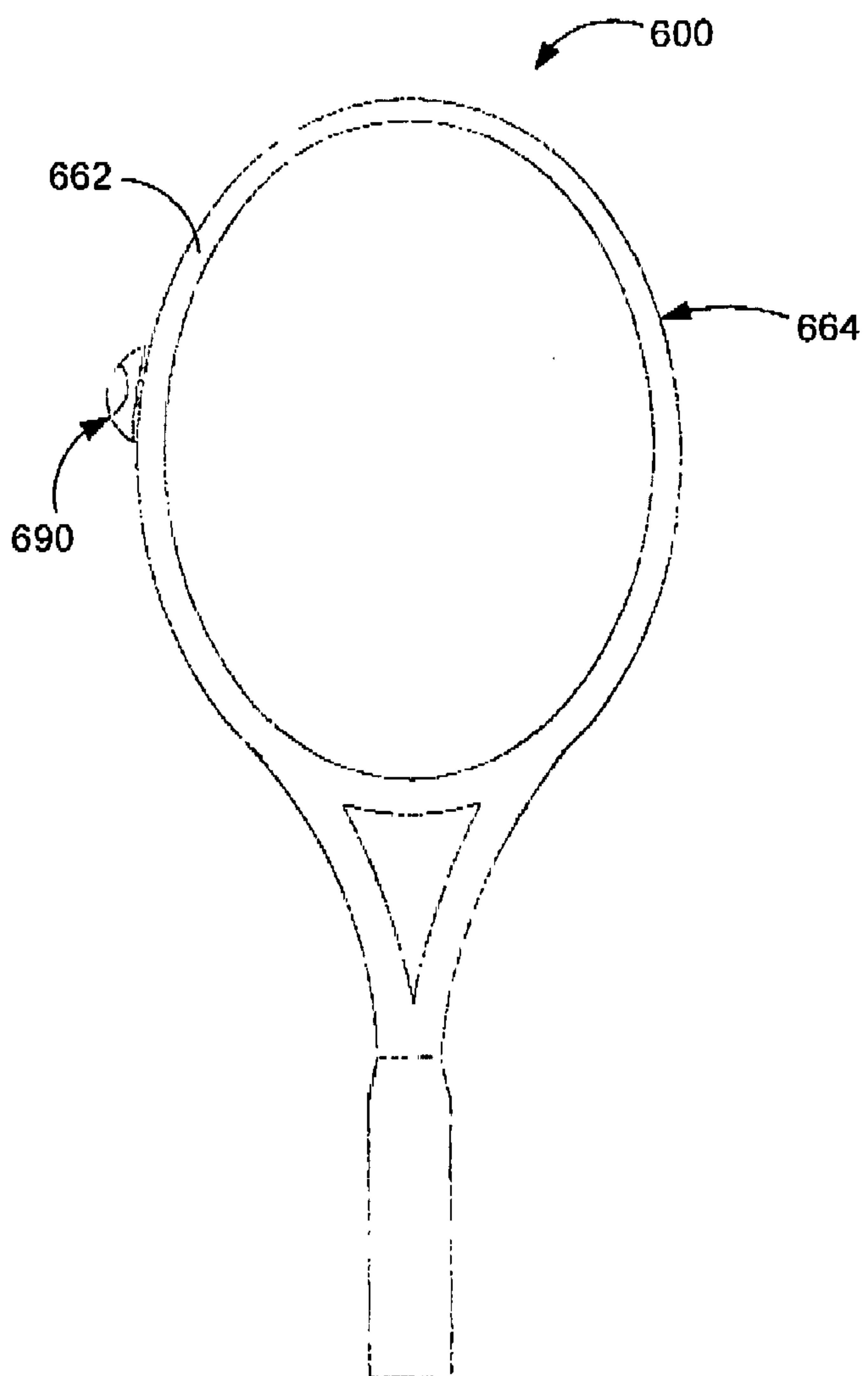

Figure 13

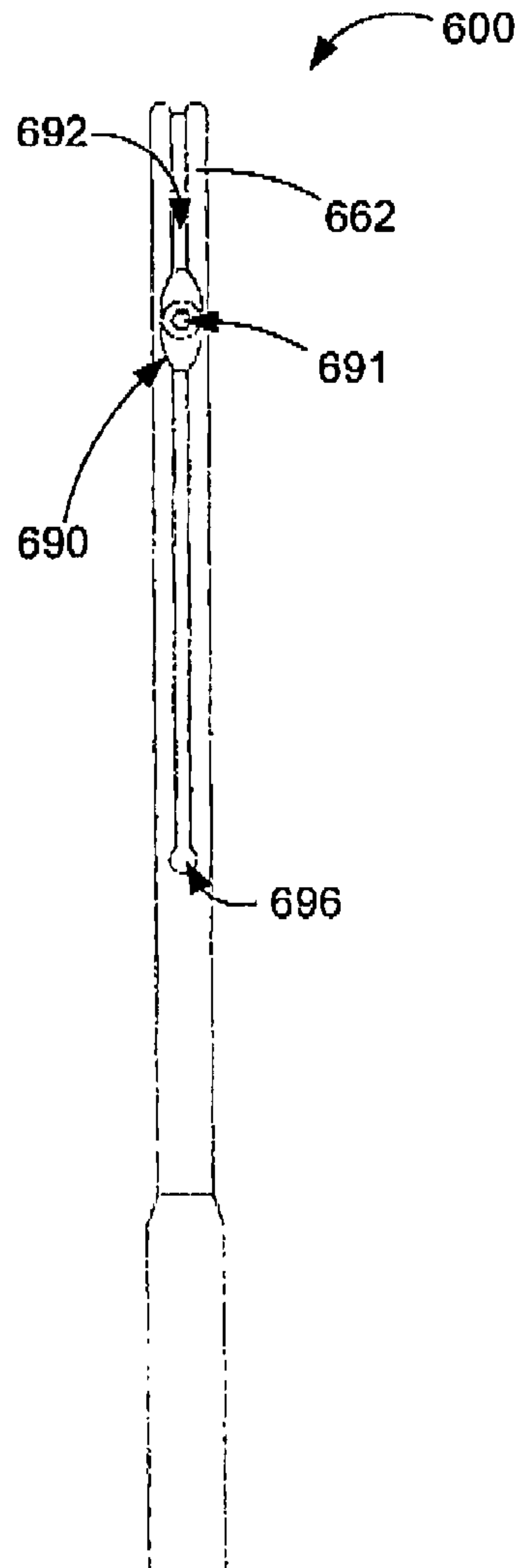

Figure 14

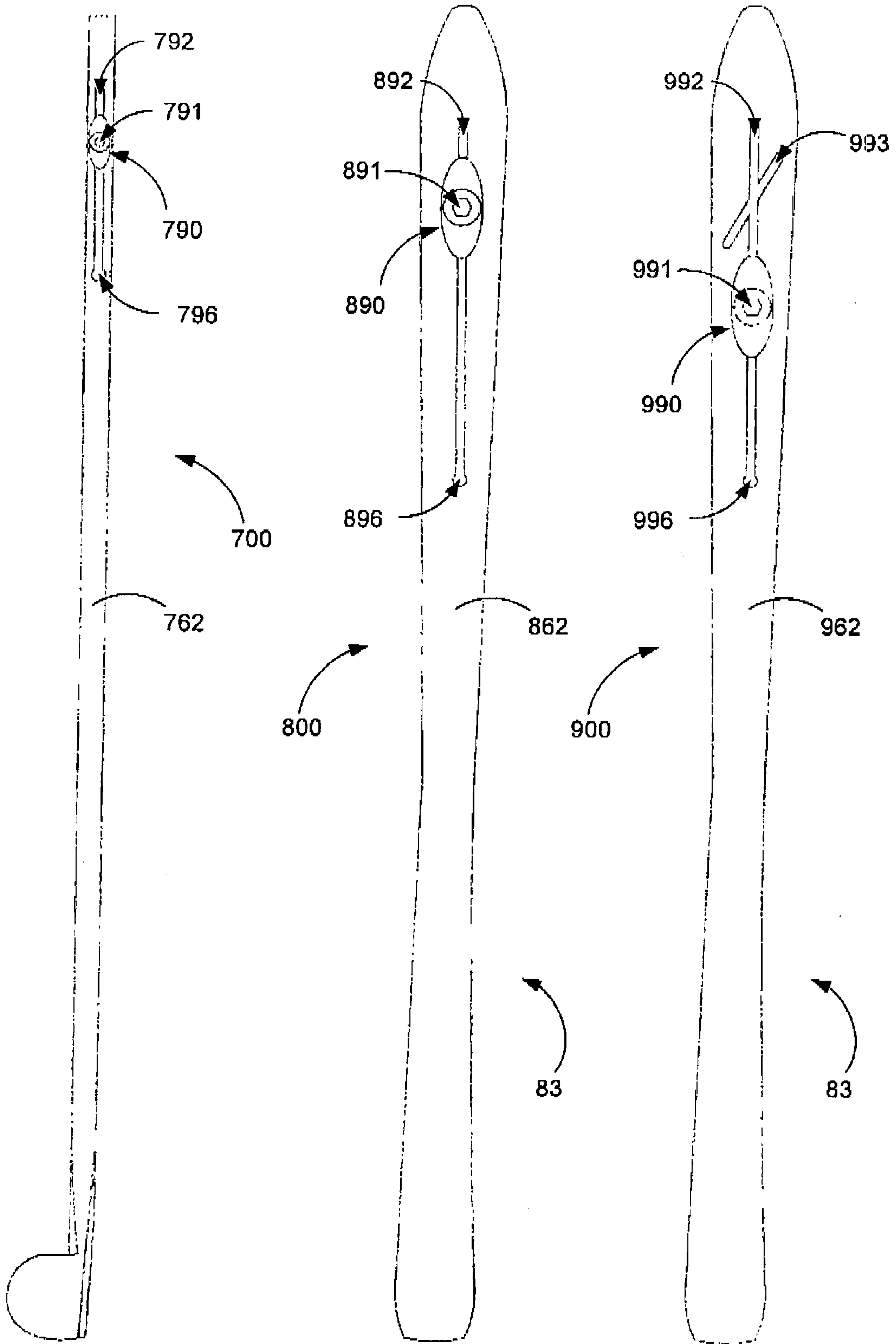

Figure 15

Figure 16

Figure 17

