

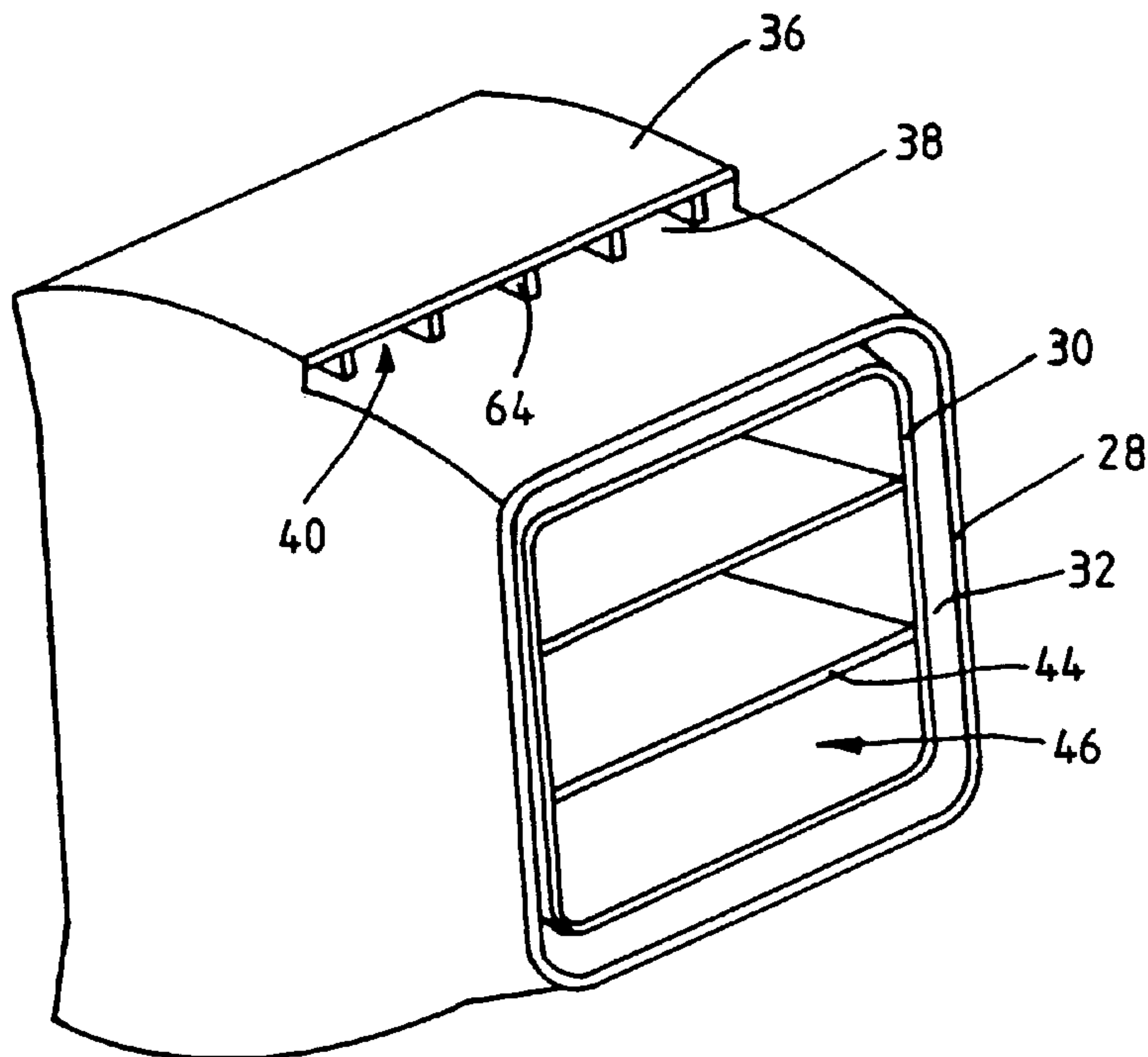

(86) Date de dépôt PCT/PCT Filing Date: 2000/09/11
 (87) Date publication PCT/PCT Publication Date: 2001/03/22
 (85) Entrée phase nationale/National Entry: 2002/03/11
 (86) N° demande PCT/PCT Application No.: IB 2000/001287
 (87) N° publication PCT/PCT Publication No.: 2001/020227
 (30) Priorité/Priority: 1999/09/13 (09/394,417) US

(51) Cl.Int.⁷/Int.Cl.⁷ F23D 1/00
 (71) Demandeur/Applicant:
FOSTER WHEELER ENERGY CORPORATION, US
 (72) Inventeur/Inventor:
GRUSHA, JOHN, US
 (74) Agent: GOWLING LAFLEUR HENDERSON LLP

(54) Titre : TUYERE D'ALIMENTATION D'UN FOUR EN MATIERE ASSURANT LA COMBUSTION
 (54) Title: A NOZZLE FOR FEEDING COMBUSTION PROVIDING MEDIUM INTO A FURNACE



(57) **Abrégé/Abstract:**

A nozzle (20) for feeding combustion maintaining medium into a furnace (10) at high temperature conditions includes a nozzle tip, partly protruding into the furnace, and a feeding mechanism. The nozzle tip includes an open ended outer shell (28), an air cooling zone (32), a shroud (36), and an air channel (40). The outer shell (28) includes a first end wall portion in flow connection with the feeding mechanism and a second end wall portion protruding into the furnace. The shroud (36) includes a shroud wall portion disposed to cover at least a portion of the first end wall portion of the outer shell (28). The shroud channel (40) is formed between the shroud wall portion of the shroud (36) and the first end wall portion of the outer shell (28), for discharging an air flow along the exterior side of the said second end wall portion.

(12) INTERNATIONAL APPLICATION PUBLISHED UNDER THE PATENT COOPERATION TREATY (PCT)

(19) World Intellectual Property Organization
International Bureau



(43) International Publication Date
22 March 2001 (22.03.2001)

PCT

(10) International Publication Number
WO 01/20227 A1

- (51) International Patent Classification⁷: F23D 1/00
- (21) International Application Number: PCT/IB00/01287
- (22) International Filing Date:
11 September 2000 (11.09.2000)
- (25) Filing Language: English
- (26) Publication Language: English
- (30) Priority Data:
09/394,417 13 September 1999 (13.09.1999) US
- (71) Applicant: FOSTER WHEELER ENERGY CORPORATION [US/US]; Perryville Corporate Park, Clinton, NJ 08809-4000 (US).
- (72) Inventor: GRUSHA, John; 306 Jefferson Place, Bethlehem, PA 18020 (US).
- (81) Designated States (*national*): AE, AG, AL, AM, AT, AU, AZ, BA, BB, BG, BR, BY, BZ, CA, CH, CN, CR, CU, CZ, DE, DK, DM, DZ, EE, ES, FI, GB, GD, GE, GH, GM, HR, HU, ID, IL, IN, IS, JP, KE, KG, KP, KR, KZ, LC, LK, LR, LS, LT, LU, LV, MA, MD, MG, MK, MN, MW, MX, MZ, NO, NZ, PL, PT, RO, RU, SD, SE, SG, SI, SK, SL, TJ, TM, TR, TT, TZ, UA, UG, UZ, VN, YU, ZA, ZW.
- (84) Designated States (*regional*): ARIPO patent (GH, GM, KE, LS, MW, MZ, SD, SL, SZ, TZ, UG, ZW), Eurasian patent (AM, AZ, BY, KG, KZ, MD, RU, TJ, TM), European patent (AT, BE, CH, CY, DE, DK, ES, FI, FR, GB, GR, IE, IT, LU, MC, NL, PT, SE), OAPI patent (BF, BJ, CF, CG, CI, CM, GA, GN, GW, ML, MR, NE, SN, TD, TG).
- Published:
— With international search report.
- For two-letter codes and other abbreviations, refer to the "Guidance Notes on Codes and Abbreviations" appearing at the beginning of each regular issue of the PCT Gazette.*

(54) Title: A NOZZLE FOR FEEDING COMBUSTION PROVIDING MEDIUM INTO A FURNACE

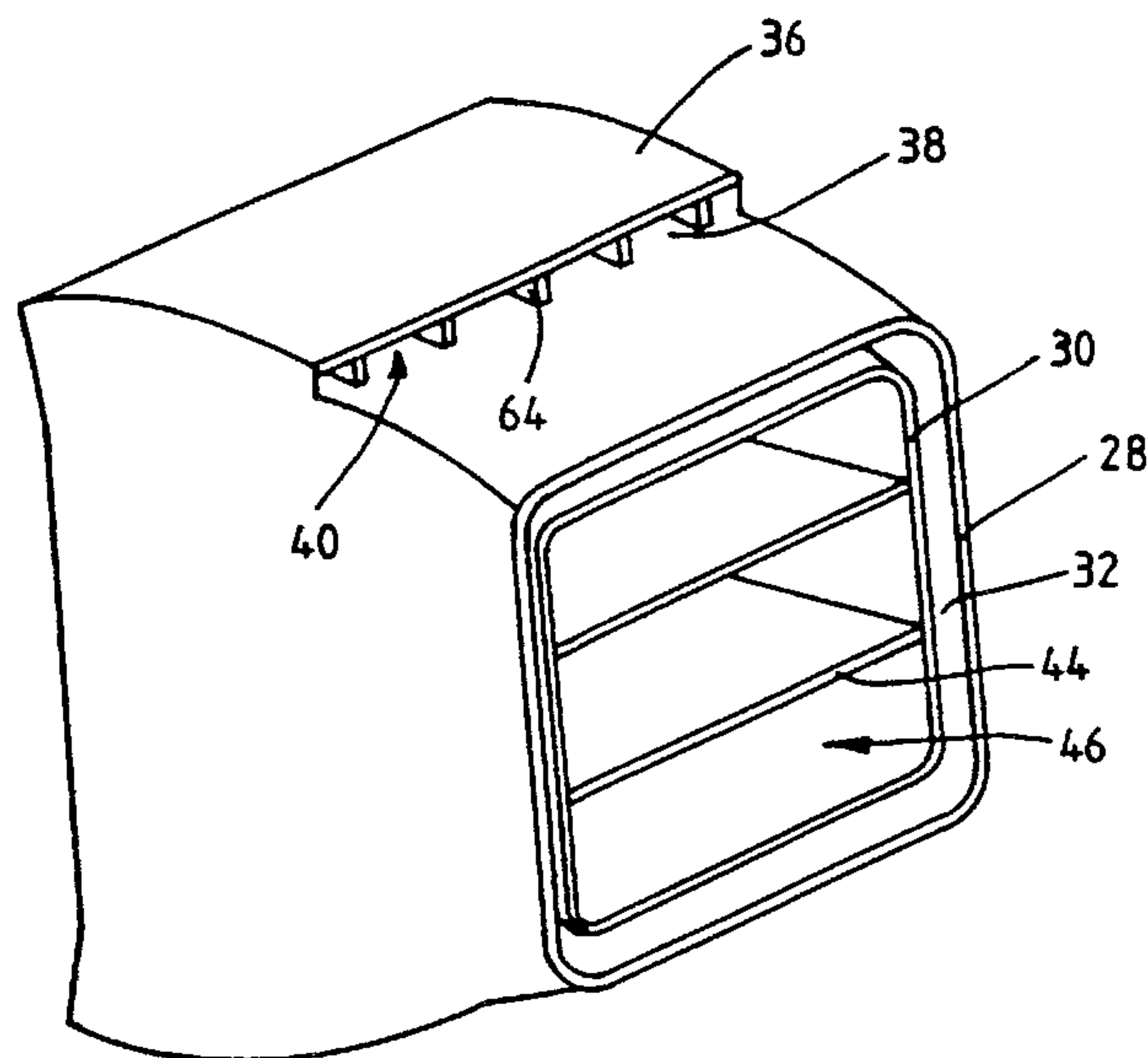

(57) Abstract: A nozzle (20) for feeding combustion maintaining medium into a furnace (10) at high temperature conditions includes a nozzle tip, partly protruding into the furnace, and a feeding mechanism. The nozzle tip includes an open ended outer shell (28), an air cooling zone (32), a shroud (36), and an air channel (40). The outer shell (28) includes a first end wall portion in flow connection with the feeding mechanism and a second end wall portion protruding into the furnace. The shroud (36) includes a shroud wall portion disposed to cover at least a portion of the first end wall portion of the outer shell (28). The shroud channel (40) is formed between the shroud wall portion of the shroud (36) and the first end wall portion of the outer shell (28), for discharging an air flow along the exterior side of the said second end wall portion.

WO 01/20227 A1

A NOZZLE FOR FEEDING COMBUSTION PROVIDING MEDIUM INTO A FURNACE

The present invention relates to nozzles feeding combustion
5 providing medium into furnaces. The present invention
thereby typically, but not exclusively, relates to
pulverized coal feeding nozzles and secondary air nozzles
in tangentially fired burners in steam generation boilers.
Tangential firing is described in US 4,252,069, US
10 4,634,054 and US 5,483,906.

Pulverized coal feeding burners typically have pivotably
arranged coal nozzle tips protruding into the furnace. The
coalnozzle tips have a double shell configuration,
15 comprising an outer shell and an inner shell. The inner
shell is coaxially disposed within the outer shell to
provide an annular space between the inner and outer
shells. The inner shell is connected to a fuel feeding
conduit or pipe, for feeding pulverized coal entrained in
20 an air flow through the inner shell into the furnace. The
annular space is connected to a secondary air conduit for
feeding secondary air through said channel into the
furnace. The secondary air is meant to provide combustion
air and cool the outer shell. The fuel feeding pipe is
25 typically disposed axially in the secondary air conduit.

The nozzle tip is located in an opening in a nozzle
supporting wall, typically in the outlet of the secondary
air box. The external cross section of the nozzle tip is
30 typically rectangular and mainly corresponds to the
internal cross section of the outlet end of the air
conduit. Narrow gaps typically remain between the periferal
walls of the nozzle tip and the walls of the air conduit.
Secondary air is allowed to leak through the narrow gaps.
35 The air typically flows horizontally into the furnace. When
the nozzle tips are arranged to discharge fuel and air
horizontally into the furnace the air leaking through the
gaps will flow mainly in the direction of the external

walls of the nozzle tips and thus protects its wall plates from furnace radiation heat.

The coal nozzle tip is typically pivotably connected to the fuel feeding pipe, in order to be able to control the level of the fire ball in tangential firing. Thus, when the nozzle tip is tilted to provide an upward or downward flow of fuel and air into the furnace, one of its walls will be bent away from the air flow leaking out and thus be more or less unprotected.

Fuel, as well as, secondary air nozzle tips of tangential fired boiler units are exposed to severe furnace conditions that can lead to thermal distortion and/or high temperature oxidation. This problem requires operators to annually replace many of their coal and air nozzle tips at a fairly high cost. Especially on tangentially fired boiler units, the conditions of the nozzle tips play a key role in sustaining long term optimal combustion performance.

20

It has been noticed that the cooling air flow flowing within the nozzle tip of fuel or air feeding nozzles cannot at certain high temperature conditions provide a sufficient cooling of the external walls of the nozzle tips. Thus the external wall plates may be heavily damaged, leading to above mentioned problems.

Exposure to direct radiation, particularly when nozzle tips are up- or downward tilted induces thermal gradients through thick stainless steel plates, 1/4 to 3/4 inch thick. The thermal gradient causes distortion and eventually closure of the passages in the nozzles, leading to performance degradation. Exposure to high radiation also results in operating temperature exceeding material limits and eventual oxidation and thinning effect of the plate resulting in "burnback" and eventual performance degradation.

It is an object of the present invention to provide an improved nozzle with which the above problems may be avoided or at least minimized.

5 It is particularly an object of the present invention to provide a nozzle the external walls of which are well protected from heat radiation.

The objects of the present invention are achieved by
10 nozzles comprising the characterizing features mentioned in the appending claims.

The present invention provides a nozzle, for feeding combustion maintaining medium into a furnace at high
15 temperature conditions. A nozzle according to the present invention includes according to a preferred embodiment a nozzle tip and fuel and/or air feeding means.

The nozzle tips may be pivotably mounted e.g. to fuel
20 feeding pipes, air feeding boxes, such as windboxes, furnace wall constructions or any other suitable conveniently located constructions. The nozzle tips are disposed so as to protrude at least partly into the furnace. Typically several nozzles may be disposed one on
25 top of the other and be connected to a vertical box mounted to the furnace wall, preferably in a corner area thereof.

Combustion maintaining medium, such as pulverized coal and air, may be fed through the feeding means and the nozzle
30 tips into the furnace. Typically pulverized coal is fed as a mixture with transport air. Secondary air may be fed separately from the coal. The nozzles may be used to feed other suitable fuels and gases, as well.

35 The nozzle tip according to a preferred embodiment of the present invention typically includes a mainly open ended outer shell and a shroud means covering a portion of the outer shell. At the first end of the outer shell the

passage inside the outer shell is in flow connection with the air feeding means. The other end of the outer shell typically protrudes into the furnace. The outer shell typically is of square or rectangular cross section, having 5 rounded corners.

The shroud means is typically made of a shroud plate which is disposed to cover a portion of the first end of the outer shell. A gas space is formed between the shroud plate 10 and the covered portion of the outer shell. Shroud air, such as secondary air is led through the gas space and discharged along the uncovered surface of the outer shell, thus providing protection against radiation heat to the outer shell. The shroud, i.e. the plate work thereof, may 15 be recessed, to form a bulbous shape and therefore be self protected from much of the radiation. Some leak air will also flow rather close to the first end of the shroud even if the nozzle tip is tilted. The leak air only later deviates from the nozzle tip and thus the leak air also 20 provides some protection close to the windbox.

Shroud plates are typically mounted to cover a portion of the upper and bottom sides of the outer shell. The shroud plate may be formed to guide the shroud air in a desired 25 direction and to provide the desired form of shroud air flow. The shroud channels or directs cooling air along the outer shell, outer plate work, of the coal or air nozzle tips, thereby providing additional cooling to those sections more exposed to radiation.

30

The nozzle tips further include an air cooling zone formed periferally on the interior side of at least a portion of the outer shell. An air flow is maintained along the interior side of the outer shell in the air cooling zone.

35

The nozzles according to the present invention are especially suitable for feeding fuel and air into tangentially fired furnaces, as the nozzle tips may be

pivotably mounted, so as to allow the direction of the flow from the nozzles to be changed. The flow may be directed upward or downward in order to control the combustion process in the furnace. Nozzle tips may be tilted either up 5 or down typically $\pm 30^\circ$. The present invention maintains an air shroud and cooling along the outer shell surface even in extreme tilted positions.

The shroud means suggested by the present invention may be 10 used to protect air nozzles from radiation in furnaces, as well. Then the air flowing through the nozzle provides the interior cooling of the outer shell and an additional air flow guided by the shroud means provides the outer protection of the nozzle tip.

15

The present invention provides effective radiation heat protection. High velocity jets, 85 ft/sec to 250 ft/sec, of air are strategically directed from specifically designed channels and blanket the nozzle tip with cooling air. The 20 air shroud provides added cooling of the nozzle and decreases thermal gradient across the plate material, due to double side cooling by air. The combined effect of the air flows in the shrouded nozzle tip, reduces the thermal stresses and the subsequent distortion.

25

The shrouded nozzle tip can be used to replace existing nozzles in existing windboxes or other supporting structures. The nozzle tips are easy to mount to existing assemblies. The operating life of the new nozzle tips is 30 long which reduces costs. The fuel and air mixing performance is maintained for longer time as nozzle tip is maintained undamaged. Also combustion efficiency is maintained over extended periods.

35 The present invention will be more closely described by referring to enclosed drawings in which
FIG. 1 shows a diagrammatic view of boiler employing the tangential firing method;

- FIG. 2 shows a cross sectional view of FIG. 1 along line AA;
- FIG. 3 shows a cross sectional view according to FIG. 2 of another furnace;
- 5 FIG. 4 shows a diagrammatic vertical cross sectional view taken in the flow direction of a coal nozzle tip according to prior art;
- FIG. 5 shows a cross sectional view as FIG. 4 of a nozzle tip in accordance with the present invention;
- 10 FIG. 6 shows a diagrammatic vertical cross sectional view taken in the flow direction of a nozzle tip in accordance with the present invention;
- FIG. 7 shows a diagrammatic vertical cross sectional view taken in the flow direction of the nozzles of a
- 15 nozzle assembly in accordance with the present invention and
- FIG. 8 shows a diagrammatic axonometric front view of a coal nozzle tip according to the present invention.

20

FIG. 1 and 2 show a furnace 10 utilizing tangential firing. Nozzle assemblies 12 are mounted to the walls 14 in the corner areas. Fuel and air flows 16 are directed tangentially toward a fire ball 18 in the center of the

25 furnace. The fire ball may be lifted or allowed to fall by tilting the nozzles 20 in the nozzle assemblies upward or downward.

The nozzle assemblies may be arranged directly in the

30 corners or close to the corner areas as shown in FIG. 3.

FIG. 4 shows a conventional coal nozzle 20 for fuel feeding. The nozzle tip 22 is mounted in the outlet end of a secondary air conduit 24. The nozzle tip is pivotably

35 mounted around an axis 26. The nozzle comprises an outer shell 28 and an inner shell 30 and an annular air channel 32 between the shells. Air is fed from the secondary air conduit 24 into air channels 32 in the nozzle tip and

discharged into the furnace 10. Additional air is leaking in horizontal air flows through openings 34 from the secondary air conduit 24 to the furnace 10 externally of the nozzle tip. Fuel is fed via conduits (not shown in the 5 drawing) through the central parts of the air conduit 24 and nozzle tip into the furnace.

The nozzle tip in FIG. 4 is tilted downward. Thus air leaking through opening 34 will not follow the upper wall 10 of the outer shell of the nozzle tip but will deviate away from the nozzle. The upper side of the wall will be unprotected against radiation and may be damaged.

Fig. 5 shows in a similar view a nozzle tip according to 15 the present invention. Same reference numerals as used in FIGS. 1 to 4 will be used. The nozzle tip is made of an outer shell 28 and an inner shell 30 coaxially located within the outer shell. Additionally a shroud means 36 is disposed on the first end portion 38 of the outer shell, 20 i.e. the end more close to the feeding means 24, to cover the first portion of the outer shell.

The shroud means 36 forms with the first end portion of the outer shell a space 40 or slot. Air is introduced into this 25 space 40 from the air conduit 24. According to the present invention an air flow from the air conduit 24 may be divided or split up to flow partly into the space 32 between the outer shell and the inner shell and to flow partly into the space 40 between the outer shell and the 30 shroud means. From the space 40 air is discharged to flow along the external surface of the outer shell and to thus protect the shell against radiation. The shroud means provides a well directed flow of cooling air, as is shown by arrows.

35

The nozzle tips may be formed of shells having a square, rectangular or circular cross sections forming annular spaces therebetween. The shroud may if desired be of

similar square, rectangular or circular cross section, but is typically made of plate material covering only the upper and bottom sides of the outer shell. An increased protection against radiation is typically mostly needed on 5 the upper and bottom sides of the nozzle tip.

FIG. 6 shows a slightly different drawing of a nozzle tip in accordance with the present invention. Same reference numerals will be used as in earlier FIGS. 1 to 5. It is 10 shown in FIG. 6 that the nozzle tip includes an inner part 42 delimited by an inner shell 30, for feeding coal. The inner part is divided by splitters 44 into separate flow channels 46. The fuel feeding conduit introducing fuel into the nozzle tip is not shown.

15

A multishroud construction is used to cover the outer shell 28. An air channel 32 is formed between the outer shell and the inner shell as in FIG. 5. The first half 38 of the upper side of the outer shell 28 is covered by a first 20 shroud 36. A first air shroud channel 40 is formed between the shell 28 and the shroud 36.

A second shroud 48 is used to cover a first portion 36' of the first shroud 36. Thus a second air shroud channel 50 is 25 formed between the first shroud portion 36' and the second shroud 48.

A multi air shroud, partly from channel 40 and partly from channel 50 is guided to flow along the upper side of the 30 nozzle tip. The air shroud from the second air channel will protect the outer shell and the first shroud from radiation. It is of course possible to add even more shrouds on top of each other in a similar manner in order to provide a multishroud construction. Deflectors 49 35 between wall plates 51 and shroud 48 are not required if wall plates 51 are moved closer to nozzle tip.

FIG. 7 shows a nozzle assembly, comprising a coal feeding

nozzle tip 52, an upper single air feeding nozzle tip 54, lower air feeding nozzle tips 56 surrounding an oil burner 58 for start up.

5 The shrouds 36 shown in nozzle tips 52, 54 and 56 in FIG. 7 are bulbous. The shrouds could be non-bulbous if desired. FIG. 7 shows more clearly than 6 how the coal feeding nozzle tip 52 may be pivotably connected to a coal feeding pipe 60 disposed axially within a secondary air conduit 62, 10 such as a windbox. The air feeding nozzles are connected to secondary air boxes, such as windboxes. The nozzle tips are downward tilted, such that the axis of the nozzle tip forms an angle α with the horizontal plane. The angle α may be $\pm 30^\circ$ from horizontal.

15

FIG. 8 shows a single coal feeding nozzle tip. same reference numbers will be used as in FIG. 6. The nozzle tip is made of an inner shell 30 and an outer shell 28, which are disposed coaxially. The interior coal feeding space 20 within the inner shell is divided by splitter plates 44 into single coal feeding subpassages 46. The annular space between the outer and inner shell provides a secondary air feeding channel 32.

25 A convex, curved shroud plate 36 is disposed on the upper side of the outer shell 28 to cover its first half 38. An air space 40 is formed between the outer shell and the shroud. Partition plates 64 are disposed in the space to form therein subpassages parallel with the flow of shroud 30 air.

The present invention is not intended to be limited to the embodiments discussed in the description above, but will cover other embodiments included in the definition of the 35 invention as defined in the appending claims. Thus besides pulverized fuel and air nozzles also overfire air, gas and oil nozzle tips are included in the scope of the invention.

Claims:

1. A nozzle for feeding combustion maintaining medium into
5 a furnace (10) at high temperature conditions, said nozzle
including
- a nozzle tip (20), at least partly protruding into said
furnace, and
- feeding means (24, 60), for feeding said combustion
10 medium from a source of said medium to said nozzle tip,

said nozzle tip including

- a mainly open ended outer shell (28), including
a first end wall portion in flow connection with
15 said feeding means and a second end wall portion
protruding into the furnace,
- an air cooling zone (32) formed on the interior
side of at least a portion of said second end wall
portion of the outer shell, by providing an air
20 flow along said interior side,
- a shroud means (48), including a shroud wall
portion disposed to cover at least a portion of
said first end wall portion of the outer shell,
- an air shroud channel (40) formed between said
25 shroud wall portion of the shroud means and said
first end wall portion of the outer shell,
for discharging from said air shroud channel an
air shroud flow along the exterior side of said
second end wall portion of the outer shell.

30

2. A nozzle according to claim 1, **wherein**
- said feeding means include a fuel feeding means (60),
such as a pulverized coal pipe,
- an open ended inner shell (30), including a first end and
35 a second end, is disposed within said outer shell,
- the first end of said inner shell is connected to
supporting means connected to the furnace construction.

3. A nozzle according to claim 2, **wherein**
- said feeding means additionally include a secondary air conduit (24, 62),
- said air cooling zone (32) is formed in a space between
5 said outer shell (28) and said inner shell (30) and
- an inlet end of the air cooling zone is in flow connection with said secondary air conduit, for leading cooling air through said space between said outer shell and said inner shell.
- 10
4. A nozzle according to claim 3, **wherein**
- said fuel feeding means comprise a pulverized coal feeding pipe (60) and
- said coal feeding pipe is disposed within said secondary
15 air conduit (62).
5. A nozzle according to claim 4, **wherein**
- said coal feeding pipe is disposed coaxially within said secondary air conduit.
- 20
6. A nozzle according to claim 2, **wherein**
- said inner shell is disposed coaxially within said outer shell and
- an annular open ended space is formed between said
25 shells, at least a portion of the annular space forming said air cooling zone.
7. A nozzle according to claim 2, **wherein**
said inner shell is divided by one or more baffle plates
30 (44), such as splitter plates, into two or more open ended fuel feeding passages (46).
8. A nozzle according to claim 2, **wherein**
said inner shell is pivotably connected to the fuel feeding
35 means.
9. A nozzle according to claim 2, **wherein**

said fuel feeding means are arranged to feed a mixture of pulverized coal and transporting air.

10. A nozzle according to claim 2, **wherein**

- 5 - said outer shell is formed of a mainly square smoothly cornered outer casing and
- said inner shell is formed of a mainly square smoothly cornered inner casing, smaller in cross section than the outer shell and disposed axially within the outer shell.

10

11. A nozzle according to claim 1, **wherein**

said shroud wall portion comprises

- a shroud wall plate disposed to cover a portion of the upper side wall of said outer shell and
- 15 - a shroud wall plate disposed to cover a portion of the bottom side wall of said outer casing.

12. A nozzle according to claim 1, **wherein** a vertical cross section of a first end in the flow direction of said shroud
20 wall plate taken parallelly to the flow direction is convex.

13. A nozzle according to claim 1, **wherein**

- said feeding means include an air flow conduit, in flow connection with an air source, such as a windbox,
- 25 - the outer shell is divided by one or more baffle plates, parallel with the air flow, into two or more air flow subpassages, said air flow subpassages having an inlet end and an outlet end,
- the inlet ends of said air flow subpassages are in flow
30 connection with said air flow conduit, and
- the outlet ends of said air flow subpassages are arranged to discharge air into the furnace.

14. A nozzle according to claim 13, **wherein** said air
35 cooling zone is formed in one of said air flow subpassages delimited by an periferal wall of the outer shell and one of said baffle plates.

15. A nozzle according to claim 15, **wherein**
- two or more air cooling zones are formed in two or more
of said air flow subpassages, each being delimited by an
periferal wall of the outer shell and one of said baffle
5 plates.

16. A nozzle according to claim 1, **wherein**
said nozzle tip is pivotably connected to a supporting
construction, such as a furnace wall or a windbox.

10

17. A nozzle according to claim 1, **wherein** the shroud wall
portion covers in air flow direction maximally only 50 % of
the length of the outer shell, leaving the second end of
the outer shell protruding into the furnace uncovered.

15

18. A nozzle according to claim 1, **wherein**
said nozzle tip comprises
- a multishroud means including said first shroud wall
portion, the first shroud wall portion including in the
20 flow direction a first end, and
- externally of said first shroud wall portion a second
shroud wall portion covering said first end thereof.

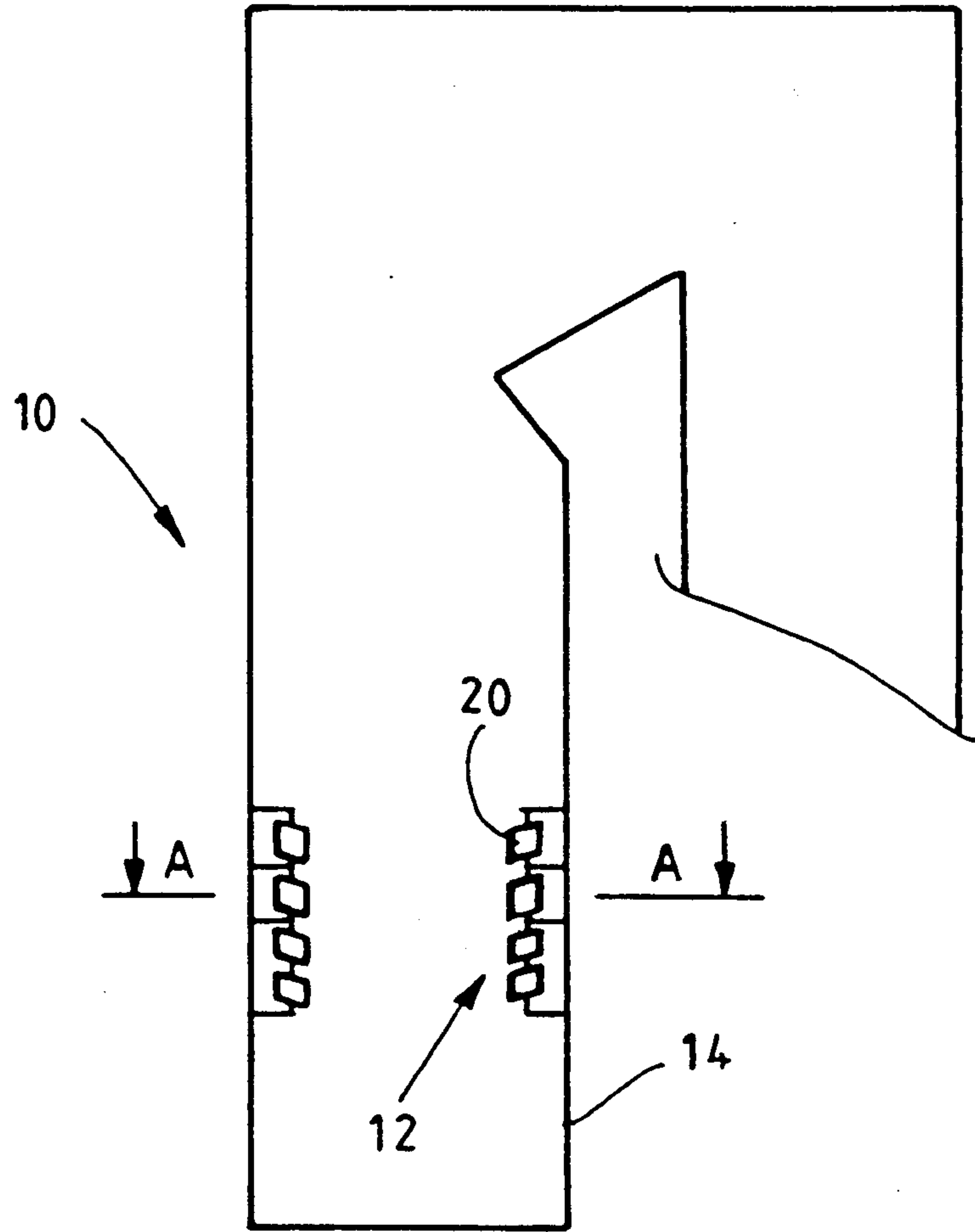

FIG. 1

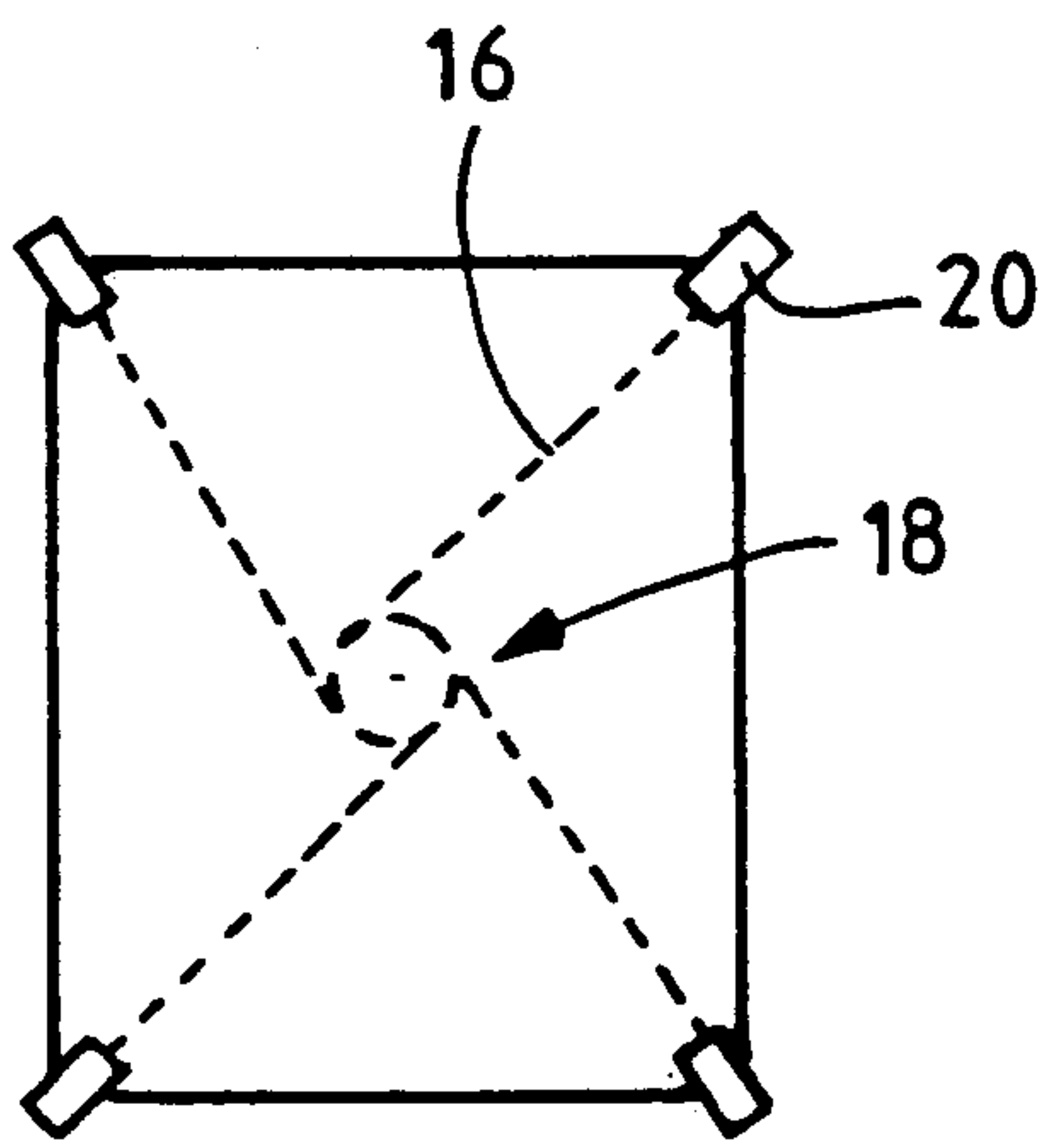

FIG. 2

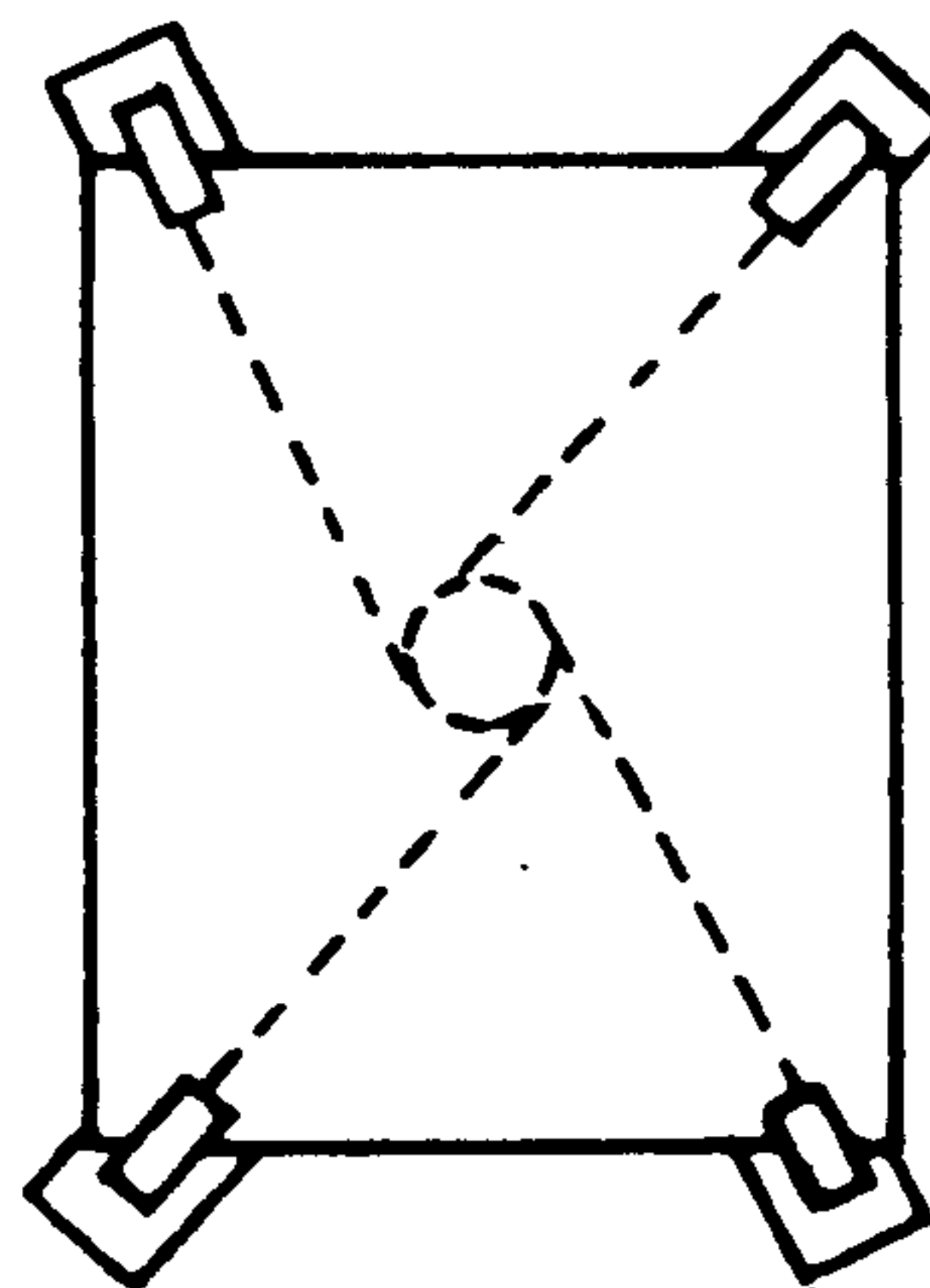

FIG. 3

2 / 4

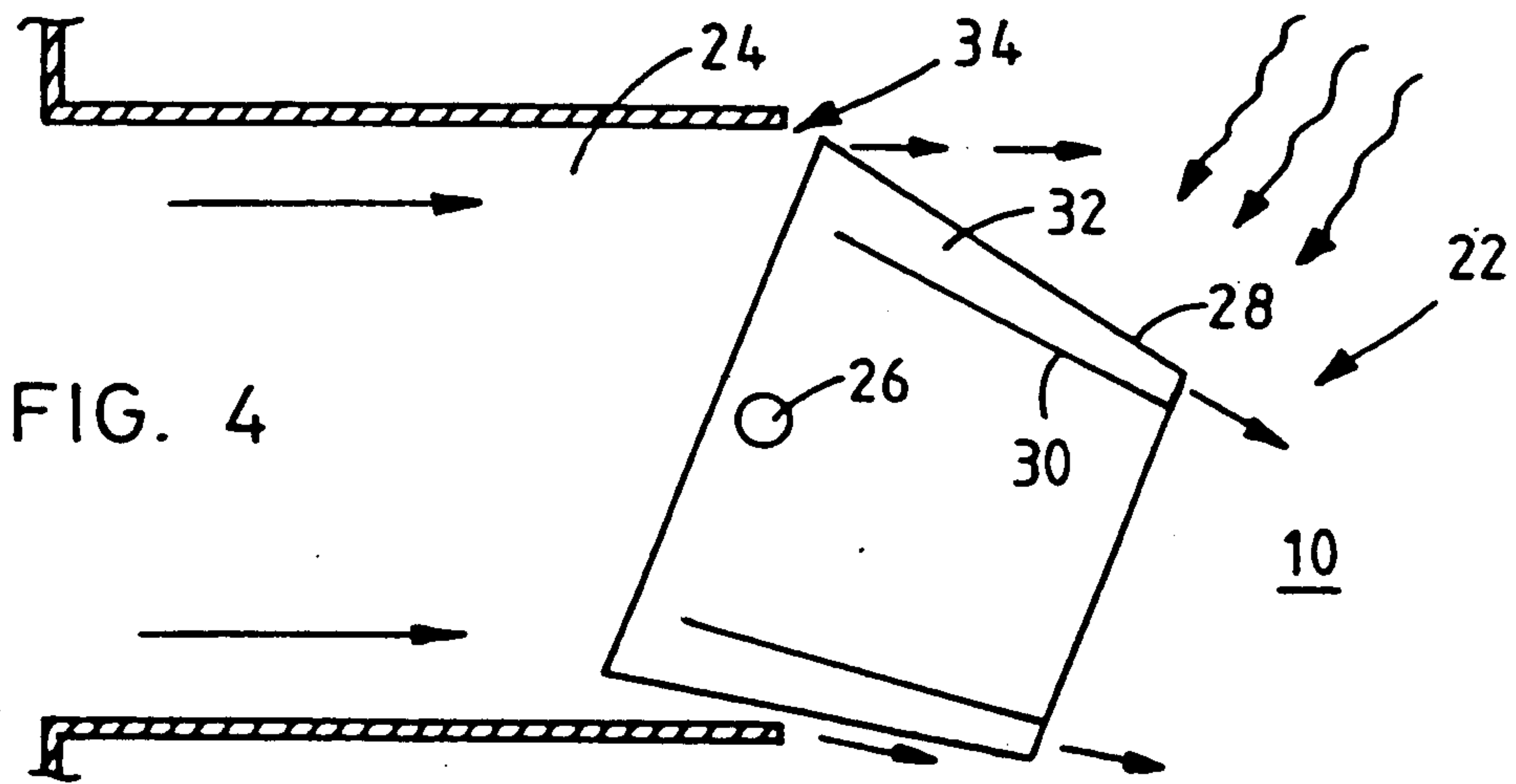

FIG. 4

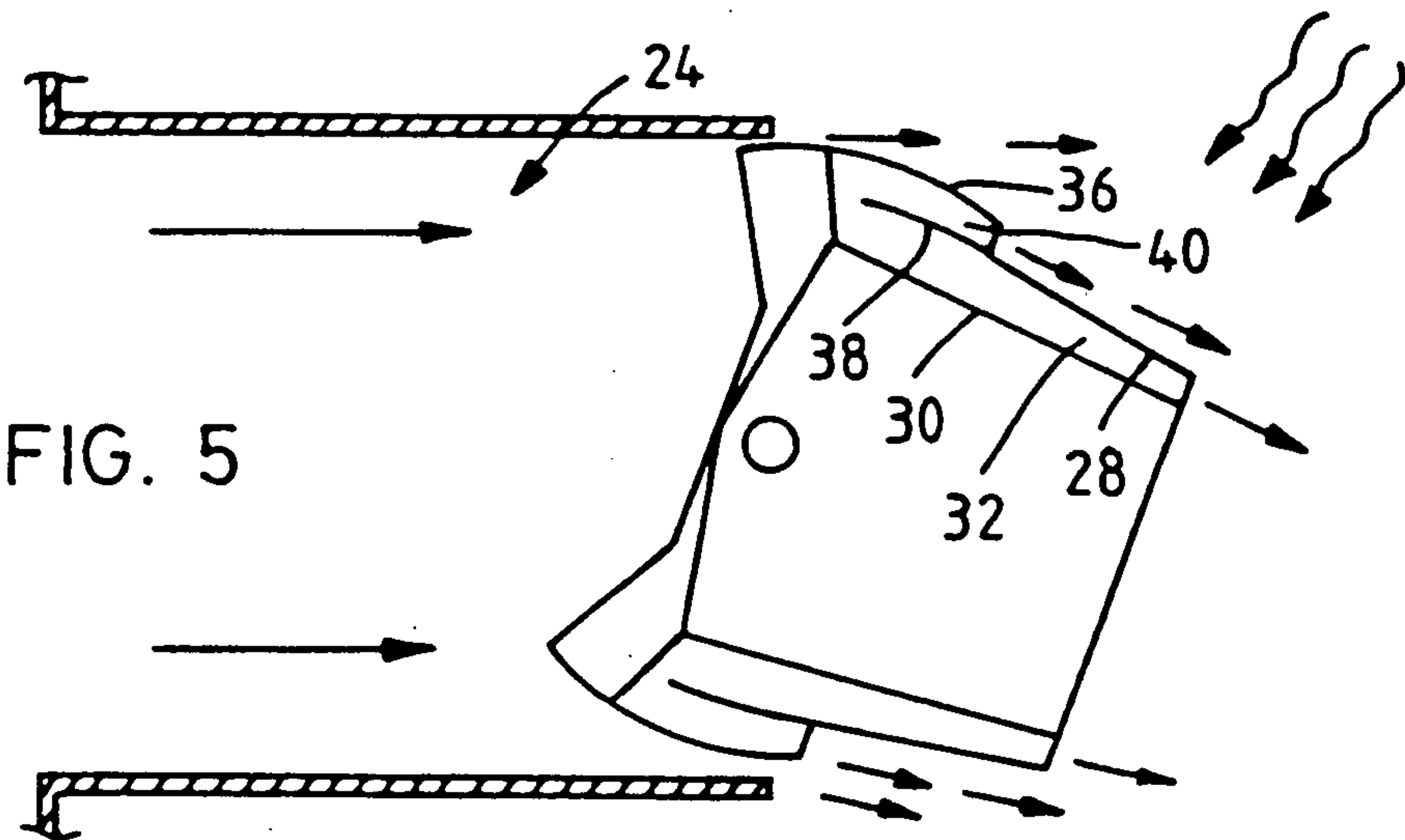

FIG. 5

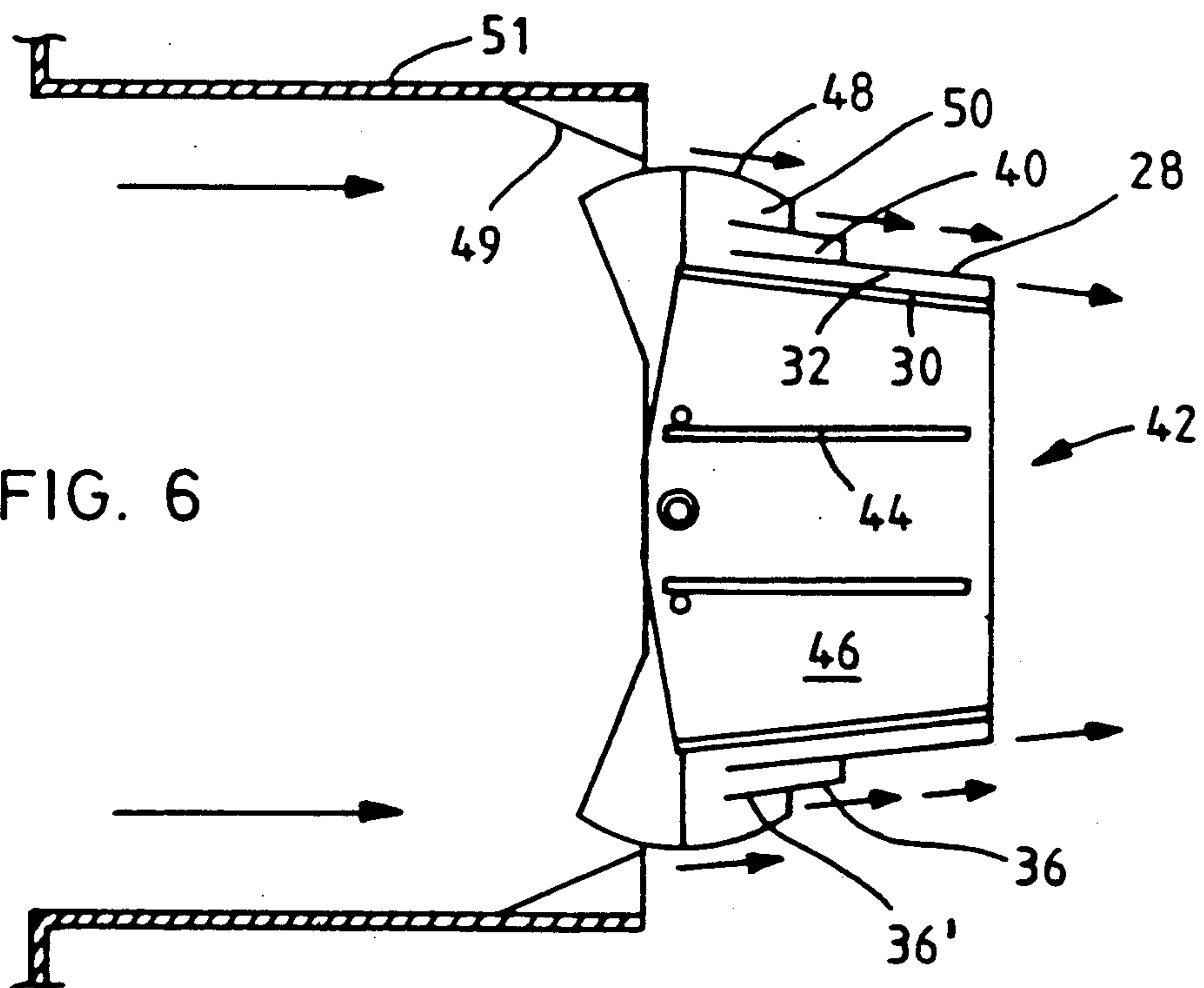

FIG. 6

3/4

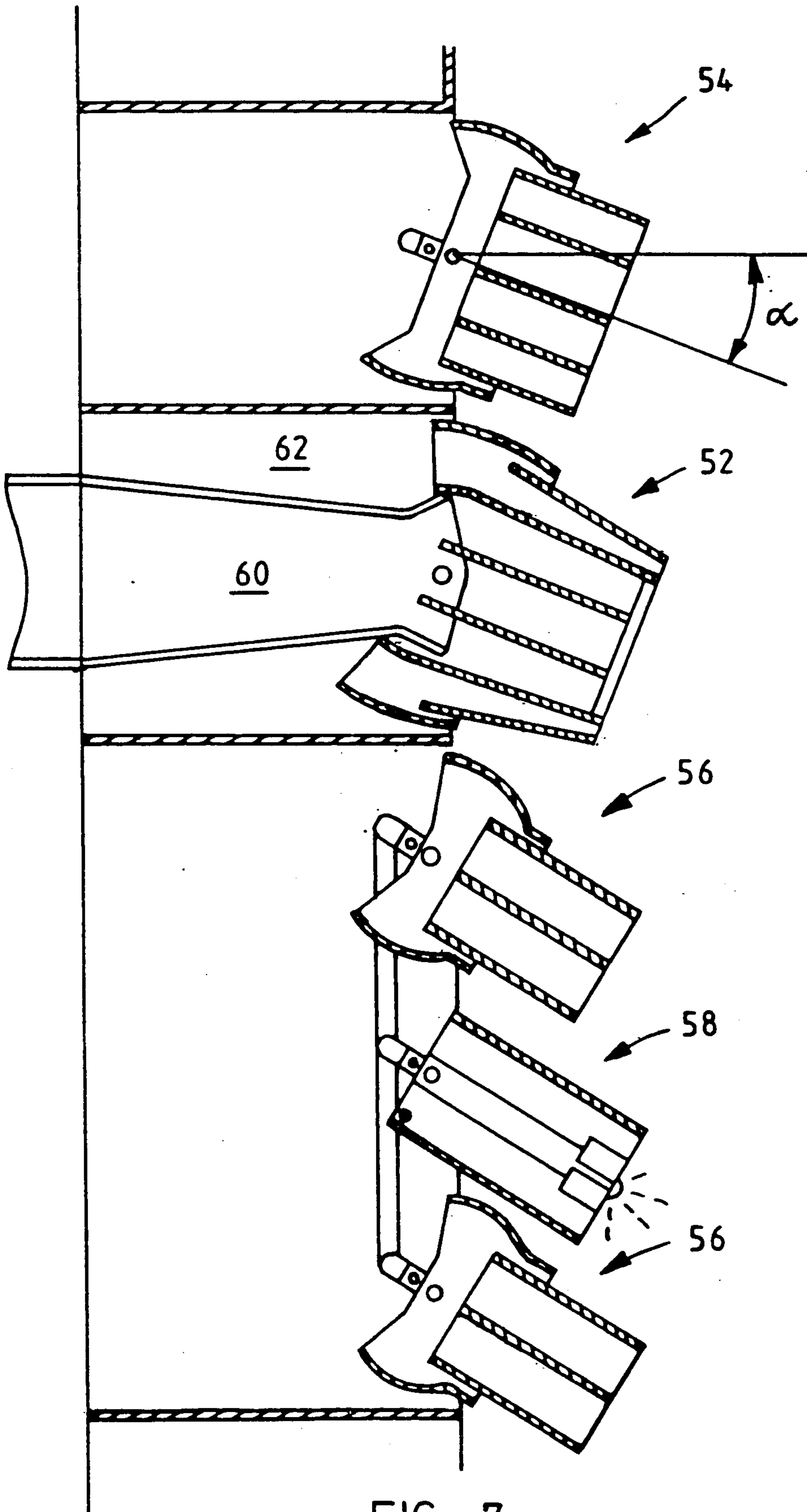

FIG. 7

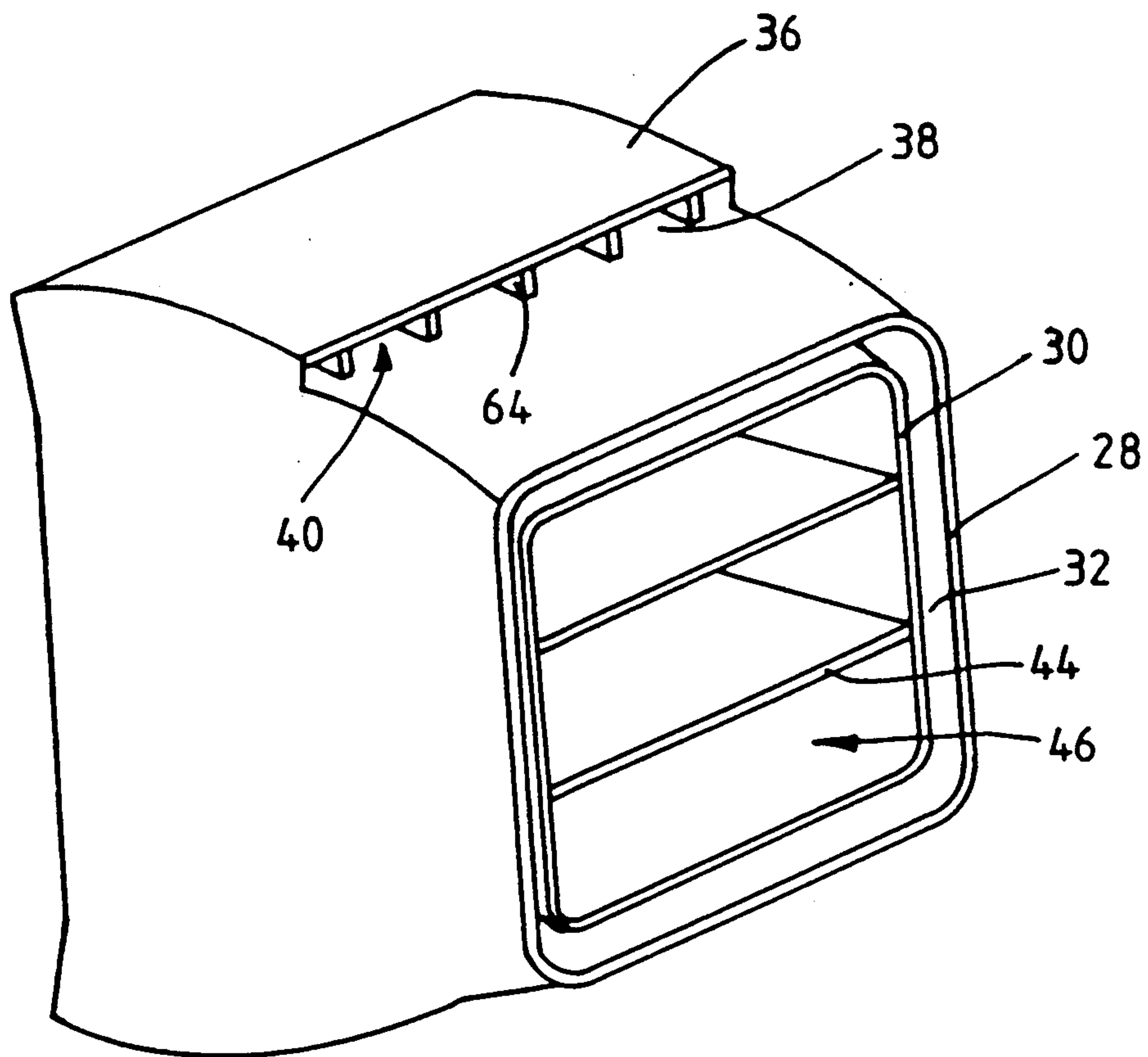

FIG. 8

